



MULTILIN

GER-2540A

GE Power Management

Automatic Reclosing of Distribution and Transmission Line Circuit Breakers



CONTENTS

Page

INTRODUCTION

APPLICATION CONSIDERATIONS – GENERAL	2
--	---

TYPE NLR RECLOSING RELAYS

GENERAL	3
APPLICATION	3
Distribution Circuits	4
Transmission Lines	5

PRINCIPLES OF OPERATION

GENERAL DESCRIPTION	5
Timing Circuit	5
Stepping Switch	5
Telephone-Type Relays	7
DISTRIBUTION CIRCUITS	7
Reclosing Circuit	7
Delayed Initial Reclosure	8
Reset Circuits	8
AC Supply Voltage	13
Special Contact Functions	13
Special Connections and Schemes	14
TRANSMISSION LINES	21
High Speed Reclosure	21
Delayed Reclosures Following Immediate Reclosure	24
Delayed Initial Reclosure	24
Reset	24
Out-of-Step Blocking	24
General Comments	25
Remote Breaker Control	25

TYPE NSR RECLOSING RELAYS

GENERAL	25
APPLICATION	26

PRINCIPLES OF OPERATION

GENERAL DESCRIPTION	26
TYPICAL CONNECTIONS	26
Initiation by 52/b	30
AC Control	30

Automatic Reclosing of Distribution and Transmission Line Circuit Breakers

L. E. Goff

*Power Systems Management
General Electric Company
6901 Elmwood Avenue
Philadelphia, Pennsylvania 19142*

INTRODUCTION

The primary purpose of this paper is to describe the operating principles of the General Electric Types NLR and NSR reclosing relays, and to discuss their application with distribution or transmission line circuit breakers. Both relays are designed to perform the same basic function – to automatically reclose a circuit breaker which has been tripped by protective relaying.

Generally speaking, the Type NLR relay, which is a multi-shot reclosing relay, is most frequently applied to circuit breakers in the distribution area; and the Type NSR relay, which is a single-shot reclosing relay, is usually applied on high-voltage transmission lines. There are, however, many exceptions to this general rule. The Type NLR relay, for example, is being increasingly used with transmission line breakers in a "selective reclosing" scheme. This arrangement initiates an immediate reclosure following instantaneous trips by primary relaying, but initiates delayed reclosures with synchronism check following delayed trips or unsuccessful initial immediate reclosures. The Type NSR relay has been applied in the distribution area where special circumstances dictate that only a single instantaneous reclosure is wanted. On distribution breaker applications, however, it is usually preferable to use the Type NLR relay even though only a single high-speed reclosure is initially desired, since this provides the means of adding delayed reclosures at a later date.

APPLICATION CONSIDERATIONS – GENERAL

The following general factors should be considered in the application of any automatic reclosing relay:

1. Interrupting Rating of Power Circuit Breaker – The derating factor applying to the interrupting rating of the power circuit breaker should be checked prior to the application of a reclosing relay or the selection of a reclosing cycle.
2. Closing Control Circuits – When automatic reclosing is used, it is essential that the closing circuits with solenoid mechanism ensure complete closure of the breaker even though the auxiliary switch on the breaker mechanism opens before the closure is complete.
3. Latch-checking Switches – In order to ensure successful operation of a breaker reclosed by a Type NSR relay, or by a Type NLR relay set for immediate initial reclosure, it is necessary that the breaker mechanism be equipped with a latch-checking switch if the mechanism is trip-free. This switch ensures that the mechanism latch is properly set for reclosure before the closing circuit is completed. Latch-checking switches are not required for non-trip-free mechanisms.
4. Control Switches – A control switch (typically Model 16SB1B9) should be provided with

automatic reclosing schemes using the Type NLR or Type NSR reclosing relays. This switch includes contacts to prevent the breaker from being automatically reclosed after it has been tripped by the control switch. The breaker must be reclosed by means of the switch before the automatic reclosing feature will be restored.

5. Undervoltage Devices – Where undervoltage devices are involved on the circuit fed by the breaker, it is usually necessary to coordinate the reclosing time and the trip time of the undervoltage device to ensure that the desired results are obtained. Where the UVD is involved in a throwover scheme, the initial reclosure usually should be faster. Where motor control is involved, it may or may not be desirable for the initial reclosure to be faster. Each application should be checked to determine the required coordination.
6. Associated Protective Relays – If high-speed reclosing is to be successful, the protective relays that tripped the breaker obviously must reopen their contacts before the breaker recloses. Some of the superseded types of induction time-overcurrent relays are not suitable for use with high-speed reclosing. If distance relays are supplied from line-side potential, their contacts should be supervised by contacts of instantaneous fault detectors to ensure that the trip circuit is open before the breaker recloses.

In addition to the above general application considerations, there are a number of specific requirements which must be considered when applying the Type NLR or NSR relays in various reclosing schemes. These are described in the sections which follow.

TYPE NLR RECLOSING RELAYS

GENERAL

The Type NLR reclosing relay is designed to initiate multiple reclosures of a circuit breaker which has been tripped by protective relaying. It is essentially a timing device, with a heavy-duty stepping switch operating contacts in response to impulses from a solid-state electronic timing circuit. The basic relay is designed for dc operation from the station battery. Models are available, however, with an internally mounted full-wave bridge rectifier for operation from an ac source.

The Type NLR reclosing relays are designed to provide a variety of reclosure combinations, from single-shot, either immediate or delayed, to immediate plus two delayed reclosures (or three delayed reclosures for some models). The total reclosing cycle is adjustable from 18 to 180 seconds. Delayed reclosure intervals can be conveniently set by means of cams. An optional reset feature, set by means of a movable link, provides three choices of reset following a successful reclosure; (1) reset occurs two steps after the reclosure; (2) reset occurs at the next reclose point; or (3) reset occurs one time step after the lockout position.

The NLR relays include a number of other features to meet requirements peculiar to certain specific areas of application. These are discussed in detail in the following paragraphs.

APPLICATION

The Type NLR family of reclosing relays finds application in two major areas of power systems:

1. Distribution area on radial circuits.
2. Transmission lines where generation is usually present at both ends of the line.

Although the general requirements of the Type NLR relay are the same in both areas, each imposes certain specific requirements which must be considered in the design of the Type NLR relay or in the associated reclosing scheme. Models now in general use in the two areas are listed in Table I. Refer to the General Electric Handbook on Protective Relays for complete model numbers for the typical voltage ratings listed.

The Type NLR21E relay is designed specifically for application with transmission line circuit breakers and would not be used in any other area. The remaining relays in Table I are intended primarily for use in the distribution area, as indicated in the table. However, these relays have been utilized with transmission line circuit breakers in some circumstances. The specific application requirements and relay features peculiar to each area are discussed in the following paragraphs.

Table I
TYPE NLR RELAYS

Type	Gen Applic Area*	AC or DC	Typical Voltage Ratings	Number of Re- closures	Remarks
NLR21A	D	DC	48,125 or 250	3	
NLR21B	D	AC	120 or 240V, 60 Hz	3	
NLR21C	D	DC	48, 125 or 250	4	Initial reclosure fixed instan- taneous
NLR21D	D	AC	120 or 240V, 60 Hz	4	Initial reclosure fixed instan- taneous
NLR21E	T	DC	48, 125 or 250	4	Initial reclosure fixed instan- taneous
NLR21G	D	DC	48 or 125	3	Fast lockout
NLR21M	D	DC	48/125	4	Dual rated
NLR21U	D	DC	48/125	3	
NLR21P	D	AC	120V 60 Hz	3	Separately adjustable delay on first step
NLR21T	D	DC	125	3	

*D = Distribution circuits;
T = Transmission lines.

Distribution Circuits

1. Coordination with Branch Fuses – The Type NLR reclosing relays are frequently applied at a main feeder breaker supplying a number of fused branch feeder circuits. Usual practice is to clear a fault on a branch feeder by first tripping the feeder breaker by instantaneous relays, and blocking the instantaneous trip circuit prior to the initial reclosure. If the fault is still present, it will be cleared the second time by the blowing of the branch feeder fuse, with time overcurrent relaying at the feeder providing back-up protection. The time overcurrent relays must, of course, coordinate with the branch fuses.

The relays in Table I designated for use on distribution circuits include means for blocking the instantaneous trip circuit prior to the initial reclosure, and means for reinstating instantaneous trip when the Type NLR relay locks out, if this is desired.

2. Blocking of Automatic LTC — Many users find it desirable to block operation of the automatic load tap changing of the substation transformer during a reclosing cycle. Means are provided in Type NLR relays, designated for distribution circuit application, to block this circuit at the start of the cycle and to reinstate it at lockout.

3. Selective Reclosing — The relays in Table I designated for distribution application areas can be connected to initiate an immediate first reclosure or a delayed first reclosure depending on which protective relays tripped the breaker. However, these NLR relays do not include means for coordinating with synchronism check relays.

Transmission Lines

1. Selective Reclosing with Synchronism Check – On transmission line applications, where a source of generation exists at each end of the line, typical practice when multishot reclosing relays are used is to initiate high-speed reclosing following instantaneous tripping by the primary pilot relaying, but to block high-speed reclosing and initiate one or more delayed reclosures, supervised by synchronism check relays, following a trip by backup relaying. The NLR21E relays for transmission line application are designed to accomplish this.
2. Out-of-Step Blocking of Reclosing — If transmission line protective relays are allowed to trip on an out-of-step condition, a common practice is to block instantaneous reclosing. An out-of-step blocking relay can be interconnected with the NLR21E relay to accomplish this.
3. The NLR21A through NLR21D models, and other relays designated in Table I for the distribution area, are applicable in some circumstances on transmission line circuit breakers when the special features of the NLR21E are not required.

PRINCIPLES OF OPERATION

GENERAL DESCRIPTION

Since the basic elements and operating principles of all Type NLR relays are the same, the following general description is given as a preliminary to the more detailed discussions of the specific schemes.

Timing Circuit

Relay operation is based on the operation of a static timing circuit and a heavy-duty stepping switch, shown schematically in Fig. 1. The switch steps once in response to each impulse from the static timing circuit. The interval between steps, that is between impulses, is controlled by the R-C characteristic of the timing circuit. The voltage across this circuit is regulated to provide identical step-time intervals, unaffected by changes in supply voltage. The step time interval can be adjusted from 0.5 to 5.0 seconds by means of rheostat R1, providing a total timing period from 18-seconds minimum (36 steps of 0.5 seconds) to 180 seconds maximum (36 steps of 5 seconds).

Stepping Switch

The stepping switch rotates its shaft through a complete revolution in 36 equal time steps. Each step is initiated by an impulse from the static timing circuit. This impulse occurs when the timing capacitor (C_1) charges to the turn-on point of the unijunction transistor. The output of the unijunction in turn fires the SCR which causes current to flow through the operating coil of the switch (SA).

The physical arrangement of the stepping switch is shown in Fig. 2. When the armature of the switch picks up, it lifts the driving pawl of the ratchet wheel to the next tooth and loads the main spring. At the same time, the armature opens an SA contact which interrupts the SCR current, turning off the SCR. The main spring then resets the armature and turns the ratchet wheel one step.

As the ratchet wheel turns the shaft, three cams are also turned. Two of these, the lockout and reset cams, are fixed and have one lobe each. They operate contacts once per revolution. The third cam, not shown in Fig. 2, has three

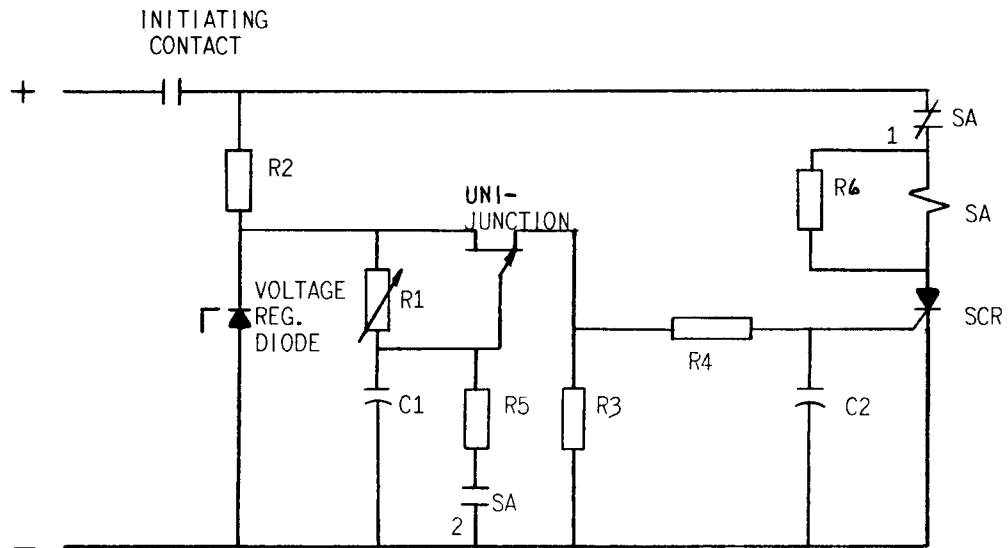

LEGEND
 SA-STEPPING SWITCH ARMATURE
 SCR-SILICON CONTROLLED RECTIFIER

Fig. 1. Timing circuit for NLR relay (0178A9145)

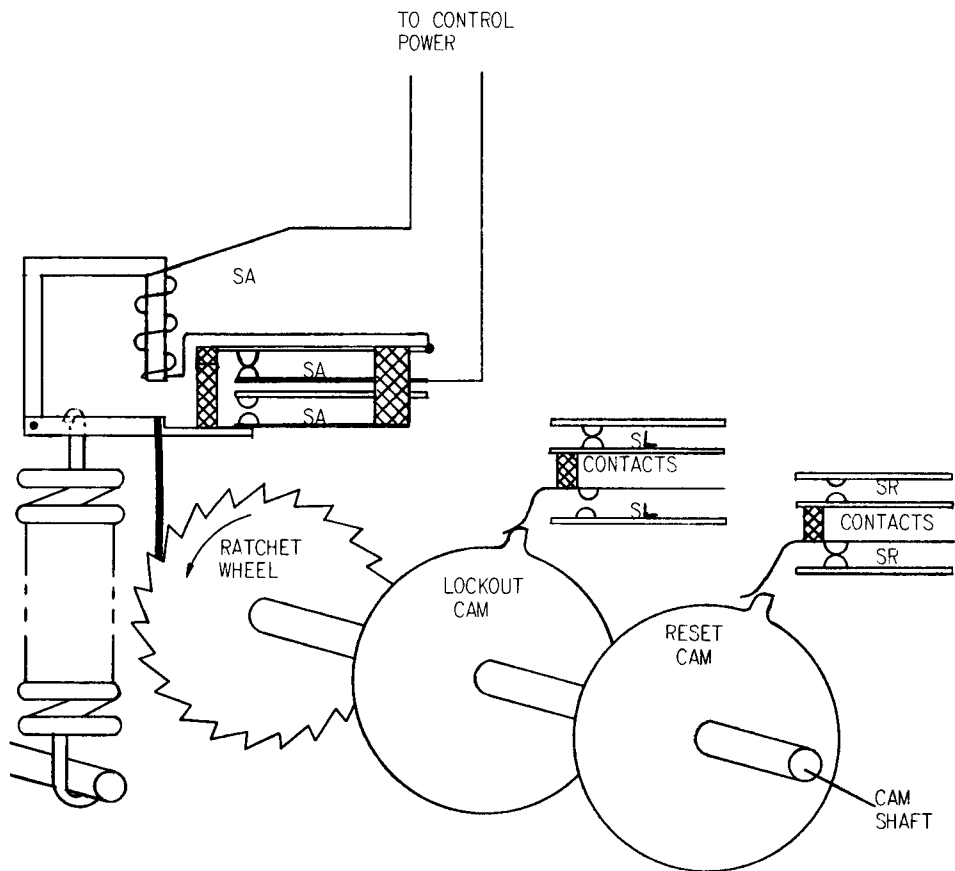

Fig. 2. Stepping switch for NLR relay (0178A9144)

adjustable lobes. These are the lobes which initiate the breaker closing signal. They can be set to initiate a reclosure at any point in the reclosing cycle, including the reset position (high-speed reclosure), as will be described later.

The lockout and reset cams each operate three contacts, one normally open (NO) and two normally closed (NC). The adjustable cam also operates three contacts, two NO and one NC. Note that the position of a contact (i.e., NO or NC) describes its condition when it is not operated by a cam of the stepping switch, and not necessarily its position when the NLR is at reset. This will be apparent in the more detailed discussions which follow.

An additional adjustable cam with one lobe operates the RS switch. This can be optionally connected to provide either a NO or NC contact. The lobe can be set to close (or open) the contact for a six-step interval at any point in the NLR relay cycle.

Telephone-Type Relays

The Type NLR relays listed in Table I, with the exception of the NLR21E and NLR21G, include two telephone-type relays mounted at the rear. The "C" unit maintains the closing signal to the circuit breaker to ensure completion of the closing operation. The "R" unit maintains the reset signal to the SA coil following a successful reclosure until the stepping switch has stepped to position 36, the reset position.

The Type NLR21E relays for application on transmission lines include, in addition to the "C" and "R" units, a CX unit which stops the timer at a delayed reclosure point until the synchronism check circuit permits reclosure.

The Type NLR21G relays, in addition to the "C" and "R" units, include an "L" unit which provides a fast lockout function.

A more detailed description of the operation of the Type NLR relays is given in the following sections describing operation of several typical schemes.

DISTRIBUTION CIRCUITS

The relays most commonly used in the distribution area are the NLR21A, NLR21C, NLR21M and NLR21U for dc applications, and the NLR21B or NLR21D for ac applications. The elementary diagram in Fig. 3 shows typical connections for the dc relays with single rating, such as the NLR21A or -21C. Dual rated dc relays such as the NLR21M and -21U are covered by Fig. 4. The cam-operated contacts SC, SL, and SR are shown as they would be with the relay in its reset position and set for an instantaneous initial reclosure. For this condition, SC1 and SC3 are held closed by a cam lobe, while SR1 and SR2 are held open.

The C unit can be connected to seal-in directly to the positive bus or through a 52/b contact. In Fig. 3 the C₁ seal-in contact is shown connected directly to positive which is permissible if the control scheme of the associated breaker is inherently pump-free. Differences in the operation of the reclosing scheme with the two connections of the C₁ contact are described in the following paragraphs.

Reclosing Circuit

The reclosing cycle is initiated by the closure of the breaker auxiliary switch 52/b when the breaker trips. This energizes the C unit coil through the closed contacts R1, SL1, and SC1, and also energizes the timing circuit through the diode D1. When the C unit picks up, it seals in directly to the positive bus through the C₁ contact, and also energizes the stepping-switch coil SA through the SA1, C7 and SC3 contacts. This causes the stepping switch to move one step immediately, as described in the preceding

GENERAL DESCRIPTION section on the Stepping Switch, resulting in the SC and SR contacts shifting to a position opposite to that shown in Fig. 3. It also discharges the timing capacitor C_1 when contact SA2 closes momentarily.

Closure of contact SC2 energizes the breaker closing circuit through contact C2 and the seal-in contact C1. Note that this seal-in contact will hold the C unit picked up for one time interval, which will maintain the pump-free closing circuit energized for this period. If the closing circuit is not inherently pump-free, an alternate connection must be used as described later. Closure of contact SR1 on the instantaneous step will keep the timing circuit energized, whether or not the breaker remains closed on the initial reclosure. Opening of contact SC3 prevents a second immediate step when SA1 recloses.

If it is assumed that the fault is permanent and the breaker trips after the initial (and subsequent) reclosures, the following sequence will occur. After the first time interval, the SCR will be gated. The C unit coil will be shorted by the SCR and C will reset. There will be no step after this time interval since contact C4 was initially open preventing operation of SA through the SCR, and the opening of contact C3 cuts off the SCR before contact C4 closes. Thus, the immediate step, which occurred when C picked up, will be regained. The overlapping contacts C5 and C6 will discharge the timing capacitor as C drops out.

The timer will continue to run and the stepping switch will continue to operate, with equal elapsed time intervals between steps, until the point of the first delayed reclosure is reached as determined by the setting of the adjustable cams. At this point, contacts SC1 and SC3 will close and SC2 will open. The resulting delayed reclosure sequence is very similar to the

immediate initial reclosure. When SC1 closes, it energizes the C unit which picks up and seals in and energizes the SA coil through C7 and SC3. The switch will then immediately step again, closing SC2 and initiating the delayed breaker reclosure through C1 and C2. As with instantaneous reclosure, the C unit will remain sealed up for one time interval, at which point the SCR will be gated, resetting the C unit. The switch will be prevented from stepping at this point by the C4 contacts, so the immediate step is again recovered.

The relay will continue to step through one or two additional delayed reclosure attempts (depending on the relay type) and eventually will reach the lockout point where SL1 and SL2 will be opened by a cam lobe, and the timing and stepping circuits will be de-energized.

Delayed Initial Reclosure

The immediate initial reclosure described above was obtained by setting an adjustable cam lobe so that the SC1 and SC3 contacts are held closed in the reset position. If a delayed initial reclosure is preferred, it is merely necessary to set the cam lobes for the desired delayed initial reclosure and for the subsequent delayed reclosure points. In the reset position, contacts SC1 and SC3 will then be open and SC2 closed. Thus, when the 52/b switch closes, the C unit will not operate but the timing circuit will be energized through diode D1. The timer will then run and the stepping switch will operate with equal time intervals between steps until the initial delayed reclosure point is reached. The sequence for the initial and subsequent delayed reclosures will be the same as described in the preceding section.

Reset Circuits

In the preceding discussions it was assumed that the fault was permanent, so that the

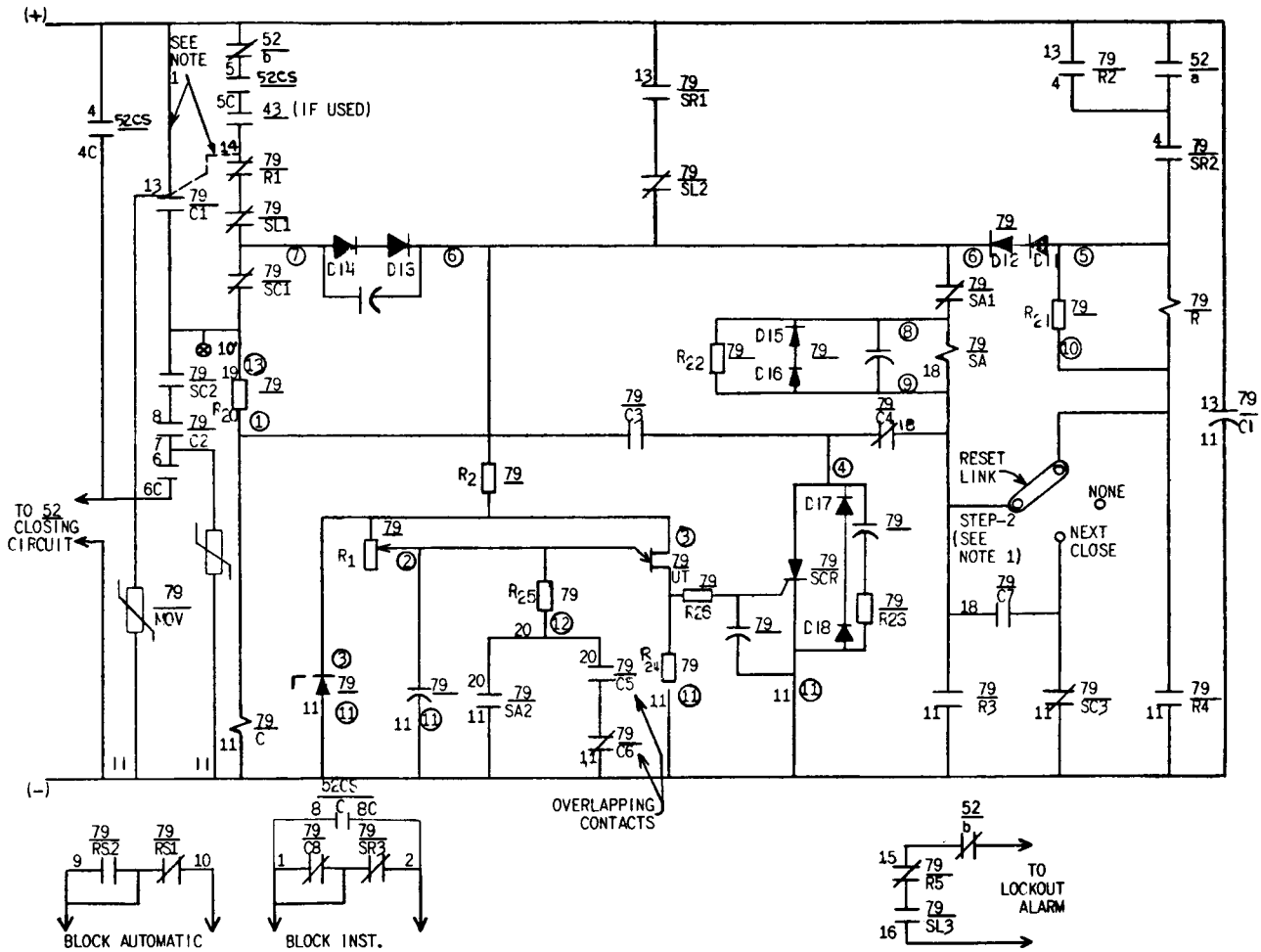

NOTE 1: USE STUD 13 CONN. NORMALLY, FOR NON-PUMP FREE CONTROL SCHEMES SHIFT INTERNAL RED LEAD FROM 13 TO 14. WHEN USING STUD 14 CONN. DO NOT USE STEP-2 RESET LINK POS. NLR21A SHOWN SET FOR INSTANTANEOUS RECLOSURE.

NOTE 2: NLR21A SHOWN SET FOR INSTANTANEOUS RECLOSURE.

CAM OPERATED CONTACTS	RESET STEP #0	STEPS 1-34	LOCKOUT STEP 35
SL			X
SR		X	
SR			X
SL		X	X
SC		X, ANY 3 NON-ADJACENT STEPS	
SC		OPEN WHEN SC IS X	
RS		X IN ANY 4 ADJACENT STEPS	
RS		OPEN WHEN RS IS X	

CONTACT NUMBER		CLOSE	NORMAL AFTER CLOSE	NORMAL AFTER TRIP	TRIP
1	2				X
2	1				X
3	4		X	X	
4	3	X			
5	6	X	X		
6	5	X	X		
7	8	X	X	X	
8	7	X	X		

DESCR. OF DEVICE	INT. CONNS.	OUTLINE
NLR21A & NLR21C	0246A3325	K-6209272

LEGEND			
DEVICE NO.	TYPE	INCL. ELEM.	DESCRIPTION
52CS	SB		CONTROL SWITCH
52			AC CIRCUIT BREAKER
79	NLR		AC RECLOSE RELAY
		C	CLOSING UNIT
		R	RESETTING UNIT
		RS	CAM OPER. AUX-FUNCTION SW.
		SA	ARMATURE OF STEPPING SW.
		SC	CLOSING CONTS. OF STEPPING SW.
		SL	LOCKOUT CONTS. OF STEPPING SW.
		SR	RESETTING CONTS. OF STEPPING SW.

⑥ - NUMBERS IN CIRCLES ARE TERMINAL POINTS ON PRINTED CIRCUIT CARD.

NUMBERS ON CONTACTS (79/R1, 79/SC1, ETC) ARE ARBITRARILY ASSIGNED FOR IDENTIFICATION PURPOSES.

Fig. 3. Typical external connections for NLR21A and NLR21C relays, distribution circuit applications, dc control voltage (0165B2631-1)

breaker tripped following each reclosure and that the NLR relay consequently stepped through its complete cycle until the lockout position was reached. A "RESET" selection link is available which can be set to provide reset following a successful reclosure. There are three choices of link position: (1) "STEP-2" position which resets the NLR two stop-time intervals after any successful breaker reclosure; (2) "NEXT CLOSE" position which initiates reset after a successful reclosure when the NLR ratchet has reached the step where the next reclosing signal will be given; and (3) the "NONE" position in which the rapid reset feature is eliminated and the NLR will not reset after any successful reclosure until the relay has stepped through its complete time cycle to one time interval after the lockout position.

The elementary diagram in Fig. 3 shows the selection link in the "STEP-2" position. Consider the immediate initial reclosure sequence previously described. The reclosure attempt occurs after the immediate step which takes place when C picks up and seals in. If the reclosure is successful, breaker auxiliary switch 52/a will remain closed which sets up the circuit through SR2, the coil of the R unit, and the selection link to contact C4 which will be open. After the first time interval the SCR drops out C but, since the SCR cuts off before contact C4 closes, there will be no step and unit R will not pick up. On the next time step when the SCR fires, unit R will pick up, seal-in through contacts R2 and R3 and block the reclose circuit at contact R1. The SA unit will then repetitively pick up and drop out and the stepping switch will run without time delay until it "homes" in the reset position where contacts SR1 and SR2 will reopen and the R unit will drop out. The NLR relay is now reset and all contacts will again be in the position shown in Fig. 3. The same rapid reset sequence will occur after a successful delayed reclosure.

With the selection link in the "NEXT CLOSE" position, the R unit will not pick up following a successful reclosure until contact SC3 closes at the next reclose position of the stepping switch. At that point, R picks up and seals-in, and the stepping switch will run without time delay, as previously described, until it "homes" in the reset position.

If the selection link is in the "NONE" position, there will be no rapid reset after a successful reclosure and the NLR relay will run through its normal cycle until the lockout position is reached. At this point, contacts SL1 and SL2 will open, but, if 52/a is closed, the timer will time out one more interval and the switch will step one more notch to the reset position.

The preceding paragraphs describe the operation with the C1 contact connected directly to positive. The C unit will be held picked up for one time interval after each reclosure, which will maintain the breaker closing circuit energized for this period. This is permissible if the closing circuit is pump-free, which is usually the case with dc circuits. An advantage of this connection of the C1 contact is that the immediate step associated with each reclosure is regained at the end of the first time interval following the reclosure. Thus, the number of time steps between reclosures will be a direct measure of the time interval between reclosures.

If the breaker closing circuit is not pump-free, it will be necessary to connect the seal-in contact C1 through a 52/b contact rather than directly to positive. This connection of contact C1 is shown as an option in Fig. 3 and results in a lost time step after each reclosure. The operation of the NLR relay for this connection is described in detail in the following section.

The external connections for the dual-rated dc models, NLR21M or NLR21U, are shown in Fig. 4. The operation of the scheme is covered by the preceding description of the single-rated relays.

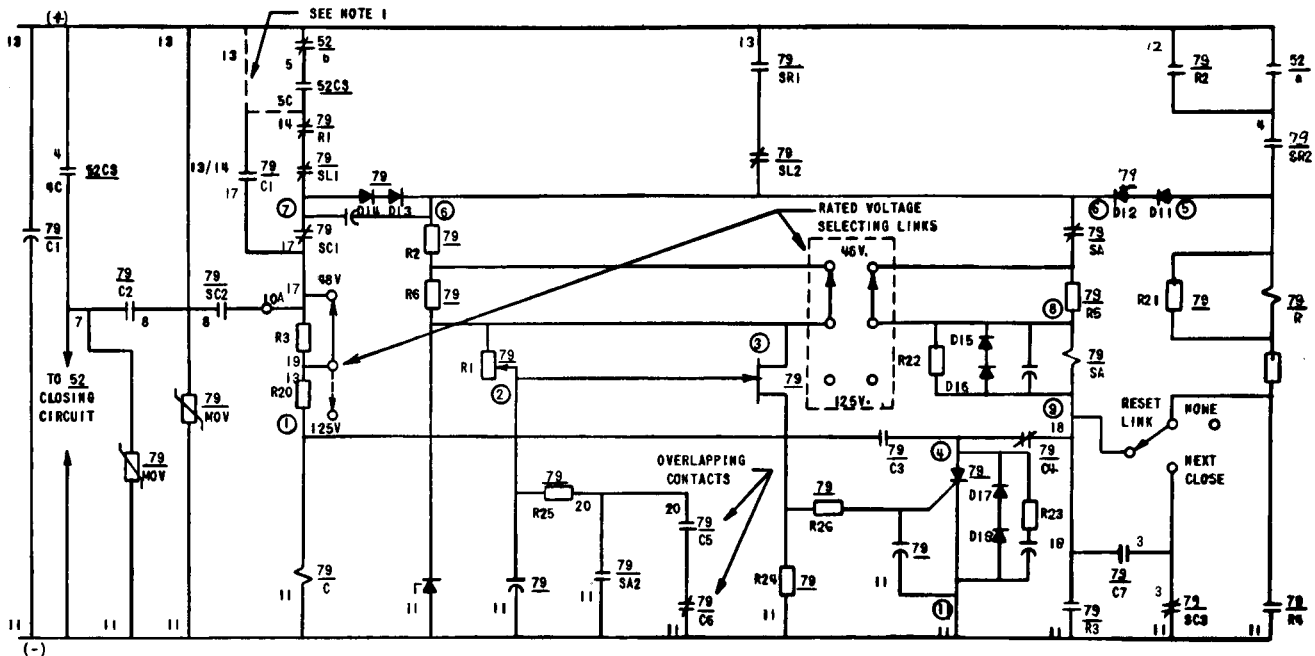

BREAKER CONTROL SWITCH MODEL 16381DD920 ST52P
W/ESCU 6402670-G2 W/NP-78848-G

CONTACT NUMBER	CLOSE	NORMAL AFTER CLOSE	NORMAL AFTER TRIP	TRIP
1	2			X
2	1			X
3	4	X	X	
4	3			
5	6	X	X	
6	5			
7	8	X	X	
8	7			

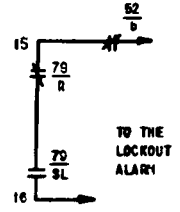
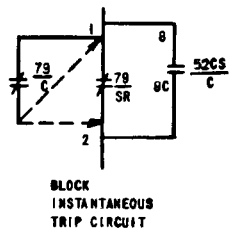
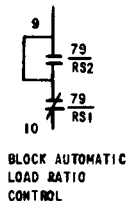

LEGEND			
DEVICE NO.	TYPE	INCL. ELEM.	DESCRIPTION
52CS	SB		CONTROL SWITCH
52			AC CIRCUIT BREAKER
79	NLR		AC RECLOSING RELAY
		C	CLOSING UNIT
		R	RESETTING UNIT
		RS	CAM OPER. AUX-FUNCTION SW
		SA	ARMATURE OF STEPPING SWITCH
		SC	CLOSING CONT'S OF STEPPING SWITCH
		SL	LOCKOUT CONT'S OF STEPPING SWITCH
		SR	RESETTING CONT'S OF STEPPING SWITCH

NOTE 1: USE STUD 13 CONNECTION NORMALLY FOR NON-PUMP FREE CONTROL SCHEMES SWIFT INTERNAL RED LEAD FROM 13 TO 14 WHEN USING STUD 14 DO NOT USE STEP 2 RESET POSITION.

NOTE 2: NLR21U SHOWN SET FOR INSTANTANEOUS RECLOSURE

CAM OPERATED CONTACTS	RESET STEP 0	STEPS 1-34	LOCKOUT STEP 35
SL	— —		X
SR	— —	X	
SR	— —	X	X
SL	— —	X	
SC	— —	X, AND 3 NON-ADJACENT STEPS	
SC	— —	OPEN WHEN SC — — IS X	
SR	— —	X IN ANY 4 ADJACENT STEPS	
SR	— —	OPEN WHEN RS — — IS X	

DESCRIPTION OF DEVICE	INTERNAL	OUTLINE
NLR21M	0240A3328	K-6209272
NLR21U	0257A5059	K-6209272

Fig. 4. Typical external connections for 12NLR21M and NLR21U reclosing relays, dual-rated, dc only (0108B8924)

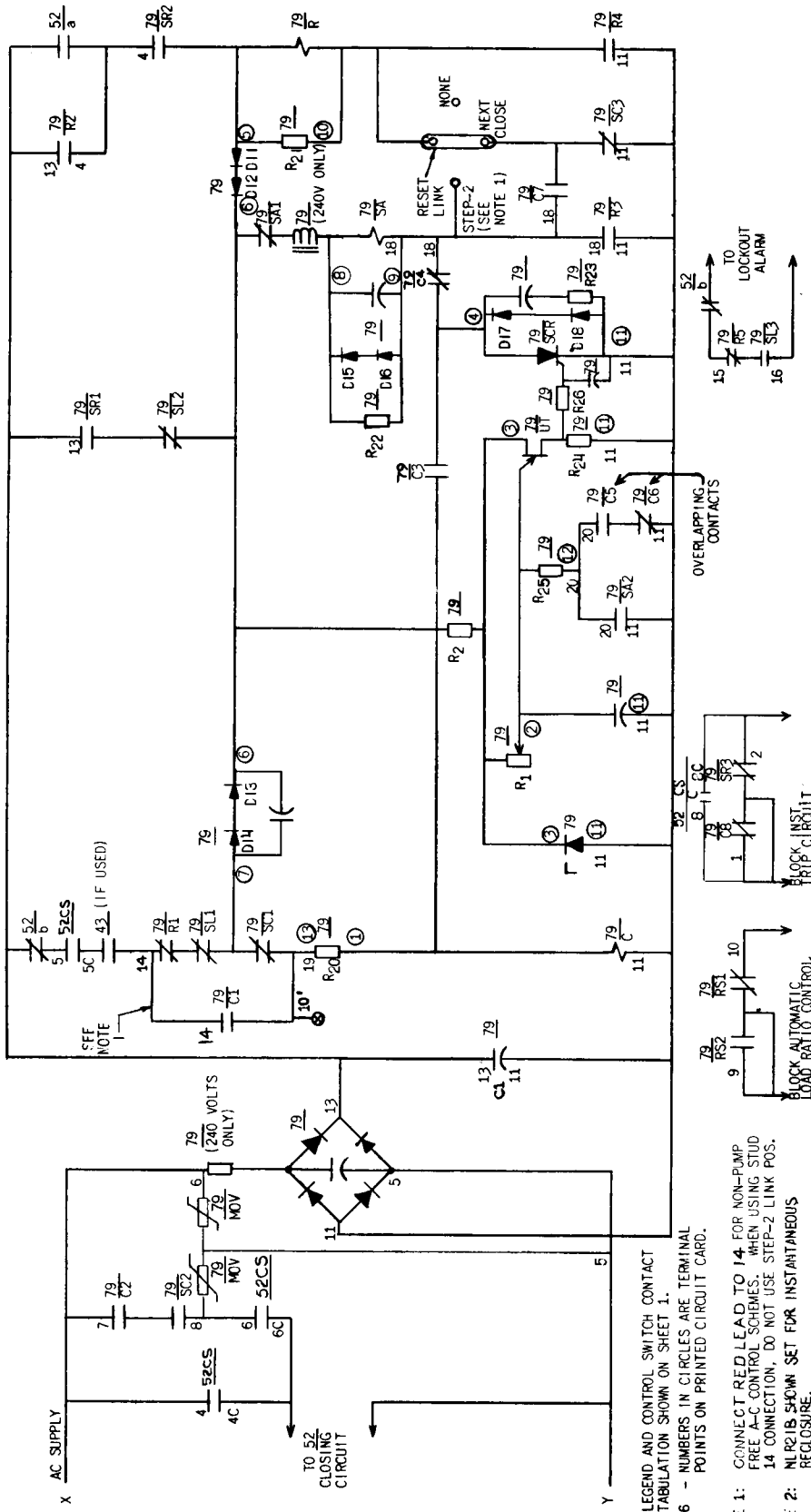

LEGEND AND CONTROL SWITCH CONTACT TABULATION SHOWN ON SHEET 1.

6 - NUMBERS IN CIRCLES ARE TERMINAL POINTS ON PRINTED CIRCUIT CARD.

NOTE 1: CONNECT RED LEAD TO 14 FOR NON-PUMP FREE A-C CONTROL SCHEMES. WHEN USING STUD 14 CONNECTION, DO NOT USE STEP-2 LINK POS.

NOTE 2: NLR21B SHOWN SET FOR INSTANTANEOUS RECLOSURE.

CAM OPERATED CONTACTS	RESET STEP #0	STEPS 1-34	LOCKOUT STEP 35
SL	+		X
SR	+	X	
SR	-	X	
SL	+	X	
SC	+	OPEN WHEN SC IS X	
RS	+	X IN ANY 4 ADJACENT STEPS	
RS	-	OPEN WHEN RS IS X	

NUMBERS ON CONTACTS (79/R1, 79/SC1, ETC) ARE ARBITRARILY ASSIGNED FOR IDENTIFICATION PURPOSES.

DEVICE NO.	TYPE	INCL. ELEM.	DESCRIPTION
52CS	SR		CONTROL SWITCH
52			AC CIRCUIT BREAKER
79	NLR		AC RECLOSING RELAY
	C		CLOSING UNIT
	R		RESETTING UNIT
	RS		CAM OPER. AUX-FUNCTION SW.
	SA		ARMATURE OF STEPPING SW.
	SC		CLOSING CONTS. OF STEPPING SW.
	SL		LOCKOUT CONTS. OF STEPPING SW.
	SR		RESETTING CONTS. OF STEPPING SW.

⑥ - NUMBERS IN CIRCLES ARE TERMINAL POINTS ON PRINTED CIRCUIT CARD.

BREAKER CONTROL SWITCH	MODEL 1658D0920	ST52P
CONTACT NUMBER	W/ESSD 830920-02 <td>TRIP</td>	TRIP
1	CLOSE	
2	1	X
3	2	X
4	3	
5	4	X
6	5	X
7	6	X
8	7	X
DESCR. OF DEVICE	INT. CONNS.	OUTLINE
NLR 21B & NLR21D	0216A3327	K-6209272

Fig. 5. Typical external connections for NLR21B and NLR21D reclosing relays, distribution circuit applications, ac control voltage (0165B2632)

AC Supply Voltage

The timing and stepping circuits of the NLR relay are inherently dc circuits. However, models are available (see Table I) which include a full-wave bridge rectifier to adapt the relay for operation from ac source. The elementary diagram in Fig. 5 shows the recommended connections. Since the ac closing circuit of the circuit breaker is not inherently pump-free, the C1 contact must be connected so that the C unit seals-in through the 52/b switch rather than directly to positive. This results in some differences in the reclosing cycle.

The elementary diagram in Fig. 5 again shows the cam-operated contacts SC, SL, and SR as they would be with the relay in its reset position and set for an immediate initial reclosure. When 52/b closes, the C unit picks up and seals-in (through 52/b), the SA coil is energized through C7 and SC3, and the stepping switch moves one step immediately. This opens SC1 and SC3, and closes SC2, energizing the closing circuit through the C2 contact. Thus far the sequence is the same as described for the dc connections with the C1 contact sealing in directly to the positive bus.

With the connections of Fig. 5 the C relay will not remain sealed in for one time interval, but will drop out when the 52/b switch opens during the initial reclosure. Consequently, at the end of the first time interval when the SCR is gated, C4 will be closed and SA will operate causing the stepping switch to move another step. Thus, the immediate step will not be regained and there will be a time step lost between successive reclosures. This must be taken into account when setting the delayed reclosure intervals.

If rapid reset following a successful reclosure is desired, it is recommended that the selection link be placed in the "NEXT CLOSE" position. Use of the "STEP-2" position will provide only one time interval between the reclosure and reset of the NLR relay. This results from the "lost

step" after each reclosure, and may be considered to be too quick, particularly if the time step interval has been set below its five second maximum value.

Special Contact Functions

A number of contact functions independent of the reclose or reset circuits are shown on the elementary diagram figures for the Distribution Circuit relays:

1. Block Instantaneous Trip – As noted under APPLICATION, it is sometimes desirable to coordinate with branch circuit fuses, by blocking the instantaneous trip circuit prior to the initial reclosure. This can be accomplished by means of the SR3 contact which is closed when the NLR relay is in the reset position and will open on the immediate step which occurs prior to a high-speed initial reclosure. Typical connections of contact SR3 to block instantaneous trip are shown in Fig. 6.

It is also possible to reinstate the instantaneous trip circuit prior to lockout by means of the RS switch as described below.

The C8 contact associated with the SR3 contact is normally jumpered out. It can, however, be reconnected in parallel with SR3 so that instantaneous tripping blocked by SR3 will be reinstated one time interval after the reclosure. With this arrangement, the instantaneous trip circuit will be blocked for one time interval, usually 5 seconds, after each subsequent delayed reclosure.

2. Function of the RS Contact — The cam which operates the RS contact is dimensioned to hold the switch in the operated position for about six steps of the stepping switch. Thus, the RS1 contact shown closed on the elementary diagram will be closed for 6 steps and open for the remaining 30 steps of the

cycle. There is a green jumper lead connected to the common point between RS1 and RS2. By shifting this jumper from stud 9 to stud 10, the RS2 contact will become the effective one and will be open for 6 steps and closed for the remaining 30 steps.

Normally, the jumper is connected to stud 9 and the cam is set so that RS1 is closed at reset, opens shortly after the start of the NLR cycle, and recloses ahead of lockout. With this normal connection, the RS1 contact is commonly connected in the control circuit of the tap changer to block automatic load tap changing while the NLR relay is operating through its reclosing cycle, and to reinstate it before the relay reaches the lockout position.

The RS1 contact with normal adjustment can be used in place of the SR3 contact in the instantaneous trip circuit to block instantaneous tripping after the initial reclosure (either immediate or delayed). This provides two instantaneous tripouts of the breaker before shifting to time delay trip to allow clearing by the branch fuse. With this arrangement, instantaneous tripping will be reinstated at lockout.

Where the SR3 contact is used to block instantaneous trip prior to the immediate initial reclosure, the RS1 contact can be used to reinstate instantaneous tripping prior to lockout. To accomplish this, the RS1 contact would be connected in parallel with SR3, and its actuating cam would be positioned to close RS1 prior to lockout, hold it closed in the lockout position, but reopen it when the relay steps to the reset position.

3. Alarm Circuit – When the relay steps to the lockout position, contact SL3 in the alarm circuit will close. If the breaker is open, the "b" switch and contact R5 will be closed and the lockout alarm circuit will be completed. The

R5 and "b" contacts prevent an alarm while the relay is passing through the lockout to reach the reset position following a successful reclosure. If the breaker should trip again during this transition period, the "b" contact will close but the NLR relay will continue to reset, since the R unit has sealed in, and will then initiate another cycle of reclosures. The R5 contact prevents the lockout alarm from operating in this situation.

Special Connections and Schemes

A number of additional functions are available, either by means of special connections to the NLR21A, -B, -C, -D, -M or -U relays previously mentioned, or by using special-purpose NLR relays as described below:

1. Selective Reclosing—External connections are shown in Fig. 7 to initiate either an immediate initial reclosure or a delayed initial reclosure, depending on what protective relay tripped the circuit breaker. The diagram in Fig. 7 specifically applies to the NLR21A or -21C relays operating from a dc control voltage. The scheme requires the use of the RS1-RS2 contacts in the instantaneous reclose circuit and the SR3 contact in the stepping circuit. This of course precludes the use of these contacts in the LTC control and instantaneous trip circuits as previously described.

All cam-operated contacts are shown in their condition with the NLR relay in the reset position. The RS cam is set so that RS1 is closed and RS2 is open in the reset position, and so they will reverse position on the first step. The adjustable SC cams are set so that SC2 is closed and SC1 and SC3 open at reset, and so SC1 closes at the desired delayed reclose points.

If the breaker is tripped by relaying with which immediate reclosing is desired, the RI unit will be picked up and, in turn, will operate C through

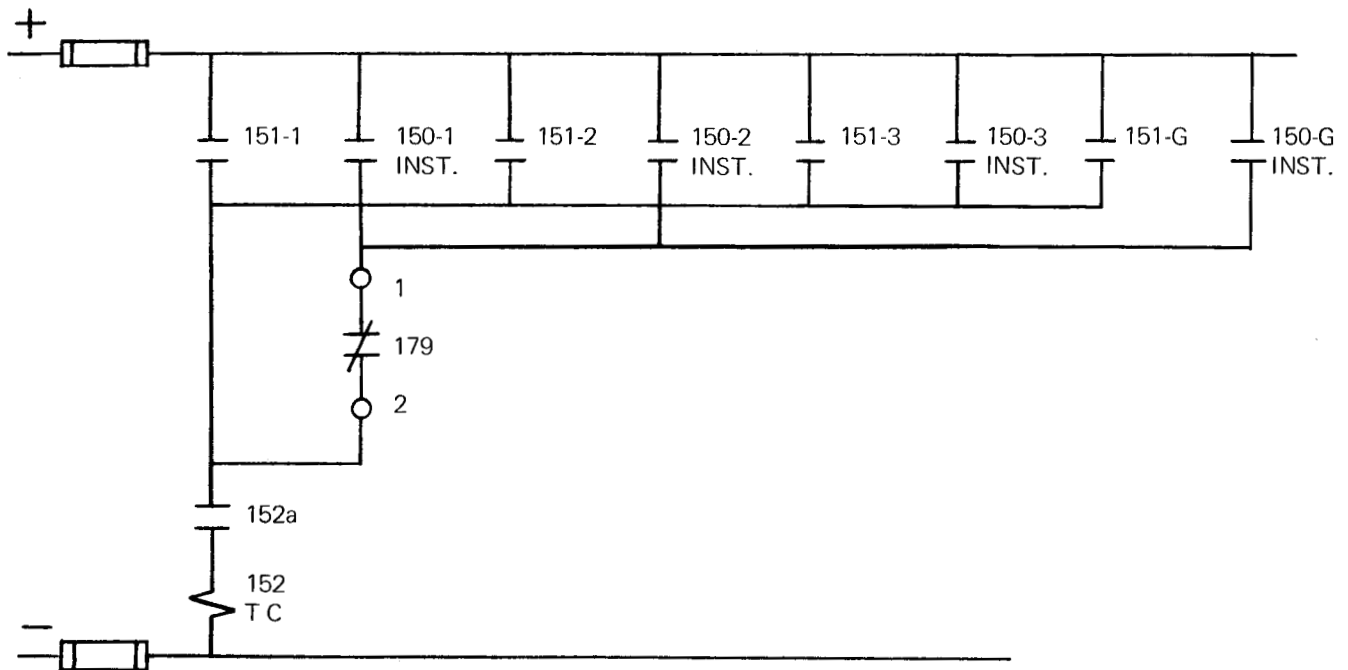

- LEGEND
 151 – TIME OVERCURRENT RELAY
 150-INST. – OVERCURRENT RELAY
 INSTANTANEOUS ATTACHMENT
 179 – BLOCKING CONTACT
 (1-2) RECLOSING RELAY
 152 – CIRCUIT BREAKER

Fig. 6. Diagram showing use of NLR contact to block instantaneous trip circuit (0178A9148)

contacts RS1 and SC2. The C unit will seal-in and will also energize the SA coil through contacts C2, R1, SL1, diode D1, SA1, C7 and SR3. The stepping switch will move one step immediately, and when contact RS2 closes, it will energize the closing circuit via contacts SC2 and C1. After the initial reclosure attempt, the NLR relay will continue to operate in the normal manner, resetting if the initial reclosure was successful or continuing through the delayed reclosure positions if the breaker retripped.

If the breaker is tripped initially by relaying which should not initiate an immediate reclosure, the RI unit will not operate and the closure of 52/b will start the timer through R1, SL1, and diode D1. The relay will then proceed

to step and initiate delayed reclosures in the normal manner. If all reclosures fail, the NLR relay will lockout in the normal manner.

The cam which actuates the RS contacts is so designed that the contact will be held closed for six steps. Consequently if the cam is set so that RS1 opens and RS2 closes on the first step, then RS2 will reopen and RS1 will reclose about four steps ahead of the lockout position. This limits the maximum delayed reclosure time since the RS2 contact is in the delayed reclosing circuit.

On manual closure following lockout, if the first close attempt is successful, the NLR relay will step once to the reset position in the normal manner previously described. However, if the

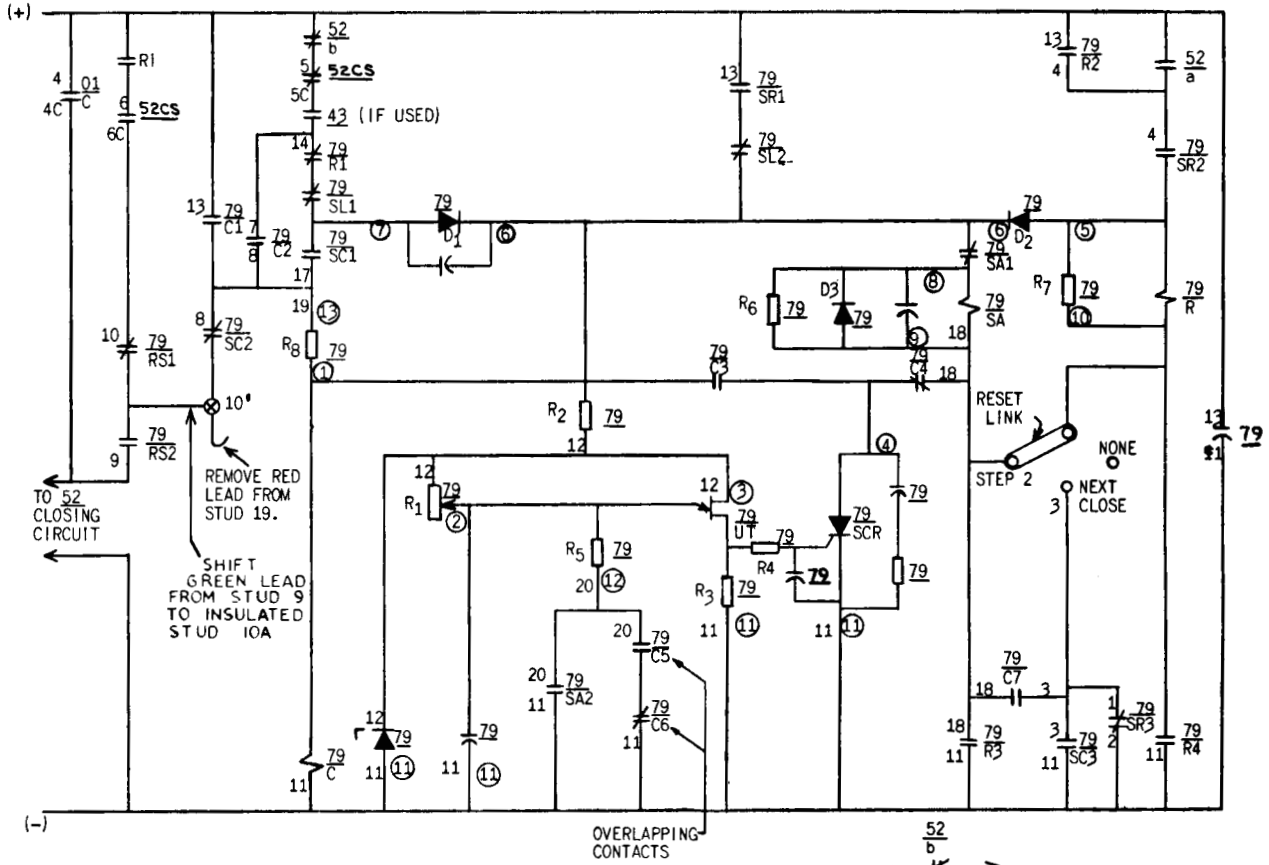

LEGEND			
DEVICE NO.	TYPE	INCL. ELEM.	DESCRIPTION
52CS	SB		CONTROL SWITCH
52			AC CIRCUIT BREAKER
79	NLR		AC RECLOSING RELAY
		C	CLOSING UNIT
		R	RESETTING UNIT
		RS	CAM OPER. AUX-FUNCTION SW.
		SA	ARMATURE OF STEPPING SW.
		SC	CLOSING CONTS. OF STEPPING SW.
		SL	LOCKOUT CONTS. OF STEPPING SW.
		SR	RESETTING CONTS. OF STEPPING SW.
RI			SELECTIVE RECLOSING (OPER. BY PRIMARY RELAYS)

BREAKER CONTROL SWITCH MODEL 16SB1B12 (X DENOTES CONTACT CLOSED)				
CONTACT NUMBER	CLOSE	NORMAL AFTER CLOSE	NORMAL AFTER TRIP	TRIP
1	2			X
3	4	X	X	X
5	6	X	X	

DESCRIPTION	INT. CONNS.	OUTLINE
NCR21A(-)A OR 21C(-)A	0246A3325	K-6209272

CAM OPERATED CONTACTS	RESET STEP #0	STEPS 1-34	LOCKOUT STEP #35
SL			X
SR	X		
SR		X	X
SL	X	X	
SC	X, ANY 3 NON-ADJACENT STEPS		
SC	OPEN WHEN SC X IS X		
RS	X IN ANY 6 ADJACENT STEPS		
RS	OPEN WHEN PS X IS X		

Fig. 7. Typical external connections for NLR21A or NLR21C reclosing relays with selective reclosing, distribution circuit application, dc control voltage only, no provision for synch check (0108B8952)

fault is still present and is so located that protective relays operate which pick up RI, then the RI contact will close momentarily. This will cause C to pick up and seal-in, but there will be no immediate step since contacts SC3 and SR3 will both be open. However, the C unit will remain sealed up after the breaker retrips. A subsequent successful manual closure will start the timer through 52/a, and diode D2. At the end of the step time interval, the SCR will fire, but there will be no step since contact C4 is open. The gated SCR will cause C to reset, however, so that at the end of the next step time interval the SCR will operate SA and the relay will step once to the reset position.

Although this scheme does provide the means of distinguishing between a breaker trip by primary pilot relaying or by delayed backup relaying, and initiating either an immediate or a delayed initial reclosure, it does not include means for coordinating with a synchronism check scheme. Consequently, the NLR21E relay, which does include such means, is recommended for transmission line applications.

2. Two Initial Instantaneous Reclosures – The diagram in Fig. 8 describes a scheme for obtaining two instantaneous reclosures followed by two (or three) additional delayed reclosures, using the NLR21A (or NLR21C) relays and a special Type NAA auxiliary relay.

On the initial tripout of the breaker, the 52/b contact will pick up 79X/A which seals in around contact SR3, and picks up the 79X/B unit. The 79X/A3 contact will operate SA, initiating an immediate step. This causes SC2 to open and SC1 and SC3 to close. It also results in the SR contacts reversing position so SR3 will now be open. The closing of SC1 initiates the first high-speed reclosure through contact 79X/A5.

When 52/b opens during the breaker closing

cycle, 79X/A will drop out, but 79X/B will remain sealed in through contact SC3. If the breaker trips again, the C unit will pick up through SC1 and 79X/A4, and another immediate step will be initiated by contact C7 through SC3. This step will open SC1 and SC3, and close SC2 to initiate a second high-speed reclosure through contacts C1, SC2 and C2. The C unit will now remain sealed in for one time interval, as with the standard NLR21A relay scheme shown in Fig. 3 and previously described.

It should be noted that if the second high-speed reclosure is to be realized, the breaker must retrip within the first time step interval, normally 5 seconds. Otherwise, the SCR will have initiated a step, reopening SC1 and preventing the C unit from picking up when 52/b closes.

The timing circuit will now time out one step time interval and gate the SCR. This resets C, but there is no step since C4 blocks the circuit through the SA coil. The second immediate step is thus regained and the NLR relay will now proceed in the normal manner to the first delayed reclosure point. If a 15 second initial delayed reclosure is desired, the second SC cam lobe should be set at position 4 to allow for the initial immediate step which was not regained.

If the breaker stayed closed after either the first or second high-speed reclosure, the NLR relay will reset after two step time intervals, which is equivalent to three steps of the stepping switch since the initial immediate step was not regained. After a successful first immediate reclosure, the 52/b contact will remain open, so when 79X/A drops out, the C unit will not pick up. The timer will now time out one interval and gate the SCR. Since contact C4 is closed, this will initiate a step. However, the 79X/B unit will still be sealed up through SC3, so contact 79X/B2 will prevent the R unit from operating and thus block reset at this point. However,

79X/B will drop out when SC3 opens on this step, so after the next step time interval, unit R will pick up, if 52/a is still closed, and the NLR will step to reset in the normal manner.

If it is the second instantaneous reclosure which is successful, 79X/B will have dropped out when SC3 opens prior to the reclosure, but R is now blocked by the C4 contact on the second step which preceded the successful reclosure, and on the firing of the SCR after the first time interval which resets C. Reset will be initiated after the second time interval or the third step of the switch.

3. Fast Lockout – The Type NLR21G relay includes an additional telephone-type relay, the L unit, which provides a means of obtaining fast lockout following the tripping of the associated breaker by certain trip paths, for example a differential relay trip, a breaker failure backup trip, or a supervisory trip. A typical external connection diagram for the NLR21G is shown in Fig. 9.

As will be noted in Fig. 9, the L unit is picked up through the SL4 contact by the 87, B, F, or SUP/T contact, except when the NLR is already in the locked out position. The L unit is sealed in by the L1 contact, and the SA coil is energized through the SL4 contact, the diode, and the contact SA1 and L3 causing the stepping switch to step immediately to the locked out position. The L2 contact in the C unit coil circuit prevents that unit from picking up and attempting a reclosure during the fast lockout cycle. The L unit is de-energized by the SL4 contact when the lockout position is reached.

4. Separately Adjustable First-step Time – The Types NLR21P and NLR21T relays are designed to initiate up to three independently adjustable delayed reclosures of a circuit breaker, the first of which can be set for a short delay as determined by a separately adjustable first-step time of 4 to 24

milliseconds. The relays are otherwise similar to the NLR21B and NLR21A respectively.

The diagram in Fig. 10 describes typical external connections for the NLR21T dc relay. All cam-operated contacts are shown in the position they will assume with the relay in its reset position. When the relay is to be set for a short-delay initial reclosure one of the three SC lobes must be set in the STEP-1 position so that contacts SC1 and SC3 will be open and SC2 will be closed in the STEP-0 position. When the reclosing cycle is initiated by the closing of the breaker auxiliary switch (52/b) the stepping switch will take its first step after a short delay, determined by the setting of potentiometer R11, causing the SC contacts to reverse position. Contacts SC1 and SC3 will now be closed and SC2 will be open. The C unit will pick up and seal in, and will close the C7 contact in the SA coil circuit. This will cause the stepping switch to immediately step again initiating the breaker closure through the SC2, C1 and C2 contacts. Note that the SR3 contact will open on the first step, opening the R11 circuit so that subsequent delayed reclosures will be determined by the normal step interval adjustment. The range of 4 to 24 milliseconds on the first-step delay is based on a normal step time interval setting of 5 seconds.

The performance of the NLR21T relay on subsequent delayed reclosures is the same as the NLR21A previously described.

5. Cumulative Lockout – The Type NLA15A stepping relay is available for those who wish to incorporate a cumulative lockout feature with their automatic reclosing scheme. When used with the NLR relay, the NLA relay will be connected to step once for each automatic reclosure, to sound an alarm after a preselected number of operations, and to lockout the automatic reclosing circuit after a certain number of subsequent operations following the alarm.

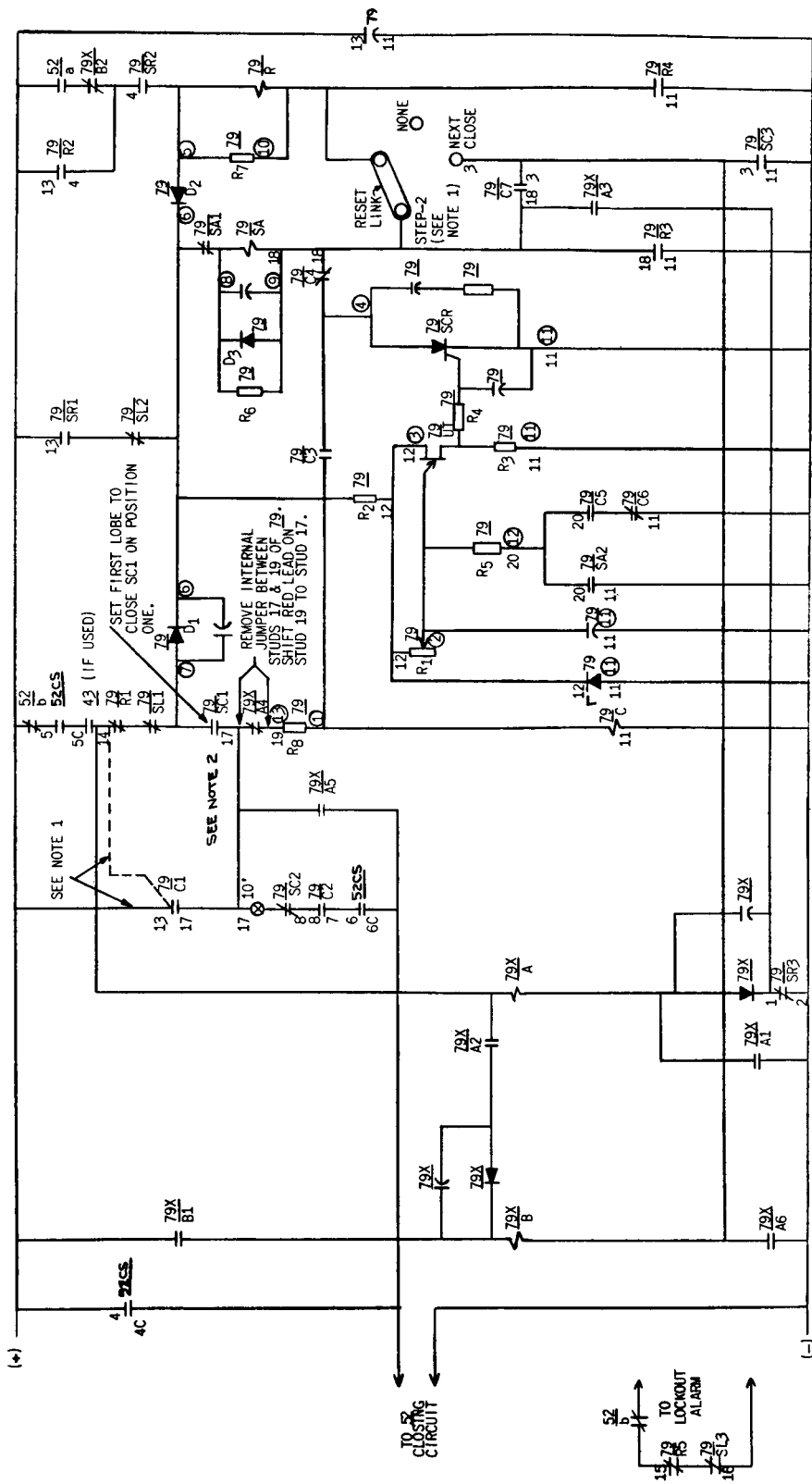

DEVICE	INT. CONNS.	OUTLINE
NLR21A(-)A & 21C(-)A	DC	0.246A3325
		K-6209272

NOTE 1:
USE STUD 13 CONN. NORMALLY FOR NON-PUMP FREE CONTROL SCHEMES. SHIFT INTERNAL RED LEAD FROM 13 TO 14. WHEN USING STUD 14 CONNECTION STEP 2 RESET LINK POSITION IS NOT RECOMMENDED.

NOTE 2:
BOTH INSTANTANEOUS RECLOSURES OCCUR AT POSITION ONE. TO PROVIDE 15 SECS. FROM INSTANTANEOUS RECLOSURES TO FIRST TIME DELAY RECLOSURE, SET 2nd LOBE ON POSITION 4 (3X STEP TIME). THE SECOND INSTANTANEOUS RECLOSURE WILL BE REALIZED IF BREAKER TRIPS WITHIN 5 SECONDS (OR ONE STEP TIME INTERVAL) OF THE FIRST INSTANTANEOUS RECLOSURE.

CAM OPERATED CONTACTS	RESET STEP #0	STEPS 1-34	LOCKOUT STEP 35
SR -4F	X		X
SR -1F		X	
SR -4F		X	
SR -1F		X	
SC -4F	X, ANY 3 NON-ADJACENT STEPS		
SC -1F	OPEN WHEN SC -4F IS X		
RS -4F	X IN ANY 6 ADJACENT STEPS		
RS -1F	OPEN WHEN RS -4F IS X		

BREAKER CONTROL SWITCH - MODEL 14-SR1B1Z X DENOTES CONTACT CLOSED			
CONTACT NUMBER	NORMAL CLOSE	NORMAL ACTIVE TRIP	TRIP
1-2			X
3	X		X
4	X		
5	X	X	
6-16	X		

DEVICE NO.	TYPE	INCL. ELEM.	DESCRIPTION
52CS	SR		CONTROL SWITCH
79	NLR		AC CIRCUIT BREAKER
	C		AC RECLOSING RELAY
	R		CLOSING UNIT
	RS		RESETTING UNIT
	SA		CAM OPER. AUX-FUNCTION SW.
	SL		ARMATURE OF STEPPING SW.
	SR		CLOSING CONTS. OF STEPPING SW.
	SC		LOCKOUT CONTS. OF STEPPING SW.
	RS		RESETTING CONTS. OF STEPPING SW.
79X	NAA		AUX. RELAY
	A		AUX. UNIT IN 79X
	B		AUX. UNIT IN 79X

Fig. 8. Typical external connections for NLR21A or NLR21C reclosing relays and associated auxiliary relay to provide two instantaneous reclosures, distribution circuit applications, dc only (0108B8953-1, -2)

NOTE 1: USE STUD 13 CONN. NORMALLY. FOR NON-PUMP FREE CONTROL SCHEMES SHIFT INTERNAL RED LEAD FROM 13 TO 14. WHEN USING STUD 14 CONN. DO NOT USE STEP-2 RESET LINK POS.

NOTE 2: NLR21G SHOWN SET FOR INSTANTANEOUS RECLOSURE.

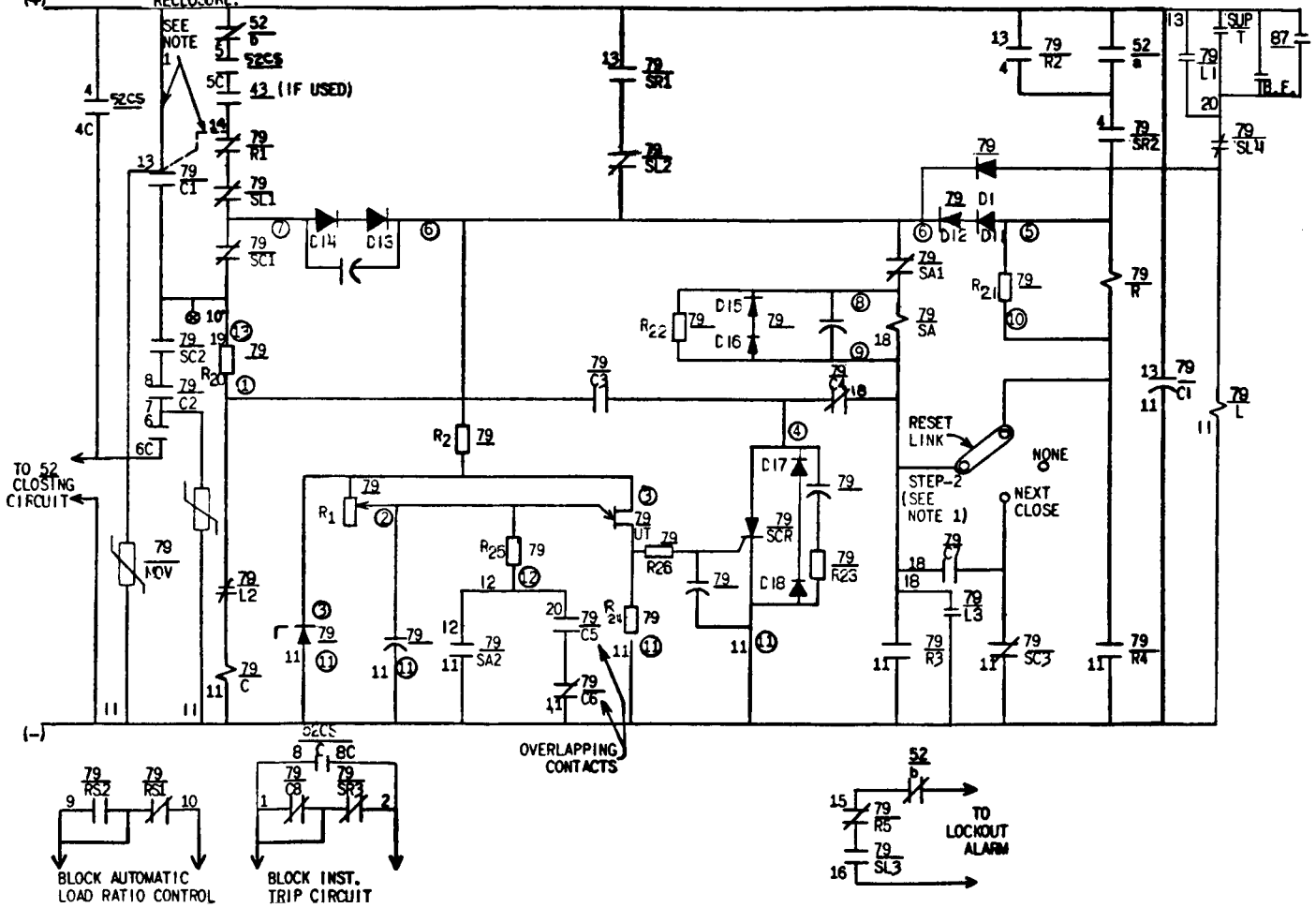

LEGEND				
DEVICE NO.	TYPE	INCL. ELEM.	DESCRIPTION	
S2CS	SB		CONTROL SWITCH	
S2			AC CIRCUIT BREAKER	
79	NLR		AC RECLOSING RELAY	
		C	CLOSING UNIT	
		R	RESETTING UNIT	
		RS	CAM OPER. ALY-FUNCTION SW.	
		SA	ARMATURE OF STEPPING SW.	
		SC	CLOSING CONTS. OF STEPPING SW.	
		SL	LOCKOUT CONTS. OF STEPPING SW.	
		SR	RESETTING CONTS. OF STEPPING SW.	
			FAST LOCKOUT UNIT	
BREAKER CONTROL SWITCH MODEL 165E1DD92C STS2P MAGNETIC 5400A370.62 W/NP - 78848 - G				
CONTACT NUMBER	CLOSE	NORMAL AFTER CLOSE	NORMAL AFTER TRIP	TRIP
1				X
2				X
3		X	X	
4	X			
5	X	X		
6	X	X		
7	X	X	X	
8	X			

DESCR. OF DEVICE	INT. CONNS.	OUTLINE
NLR21G	0246A3635	K-62C9272

Ⓢ - NUMBERS IN CIRCLES ARE TERMINAL POINTS ON PRINTED CIRCUIT CARD.

NUMBERS ON CONTACTS (79/R1, 79/SC1, ETC) ARE ARBITRARILY ASSIGNED FOR IDENTIFICATION PURPOSES.

CAM OPERATED CONTACTS	RESET STEP. NO	STEPS 1-34	LOCKOUT STEP 35
SL			X
SR	X		
SR		X	X
SL	X	X	
SC	X ANY 3 NON-ADJACENT STEPS		
SC	OPEN WHEN SC IS X		
RS	X IN ANY 4 ADJACENT STEPS		
RS	OPEN WHEN RS IS X		

Fig. 9. Typical external connections for the NLR21G reclosing relay, fast lock-out scheme, dc supply (0165B2635)

TRANSMISSION LINES

The circuits previously described have been applied in some instances with transmission line circuit breakers. Usually, however, the application of multi-shot reclosing relays on transmission lines involves special considerations. Since generation is usually present in back of each terminal of the line, a selective reclosing scheme is needed which initiates an immediate reclosure or a delayed reclosure depending on protective relay operation. If an immediate reclosure is to be successful, it is essential that the breakers at all terminals of the line be open before any breaker is reclosed. Consequently, some form of pilot relaying is necessary, with immediate reclosing initiated only if the breaker is tripped by the pilot relaying. If the breaker is tripped by time back-up relays, the initial reclosure will be delayed, and will usually be supervised by synchronism check or dead-line check relays. Furthermore, it is sometimes desirable to block immediate reclosing if the primary pilot relaying is allowed to trip on an out-of-step condition.

The Type NLR21E relay is designed specifically for application on transmission lines. It includes means for achieving immediate initial reclosure following a pilot relay trip, and for coordinating the delayed reclosure with a synchronism check circuit following a delayed trip by backup relays. It can also be interconnected with the contacts of the out-of-step blocking auxiliary (OB) of a Type CEB12B or CEB51A relay to prevent a high-speed reclosure if the primary relays operate on an out-of-step condition. The elementary diagram in Fig. 11 shows the recommended connections of the Type NLR21E relay.

High Speed Reclosure

All contacts in Fig. 11 are shown as they would be with the NLR relay in its reset position and no fault on the line. Cam-operated contacts SC1, SC3, and SR3 are held closed by a cam lobe and will open on the first step of the stepping switch, while SC2 is held open and will close on the first step. Contacts RS1 and RS2 are held in the positions shown by a cam lobe, but will not change positions until the switch steps the second time.

If the primary pilot relays operate, they will energize RI and the breaker trip coil at the same time. Closure of RI will energize the CX auxiliary unit through SR3, and will also energize the timing circuit through diode D2. Operation of CX will pick up C through contacts CX1 and CX2 and diode D2. Contact CX3 will discharge the timing capacitor. Closure of contact C7 will energize the SA coil and cause the stepping switch to step once immediately, closing SC2 and setting up the circuit to the breaker closing circuit. When the "bd" and/or "b" contacts close, the breaker closing circuit will be energized through contacts CX1, C2, SC2, and RS1. Note that the immediate step also opens SC1, SC3 and SR3. However, the RS1 contacts are still closed since the cam was set to cause the RS contacts to change position on the second step.

The RI unit will reset when the fault is cleared and 52/b will reopen during the initial reclosure. Hence, the CX unit will drop out and the path to the breaker closing circuit will be open if the breaker should retrip. The C unit will remain sealed in.

When the CX unit drops out, the timing capacitor will start to charge through SR1 and SL2. At the end of the first time interval, the SCR will be gated. The C unit will reset, but there will be no step since C4 was open when the SCR was gated. This sequence "regains" the immediate step as described previously for the NLR21A relay. At the end of the next time interval, the stepping switch will step for the second time, opening RS1 and closing RS2.

NOTE 1: USE STUD 13 CONN. NORMALLY. FOR NON-PUMP FREE CONTROL SCHEMES SHIFT INTERNAL RED LEAD FROM 13 TO 14. WHEN USING STUD 14 CONN. DO NOT USE STEP-2 RESET LINK POS.

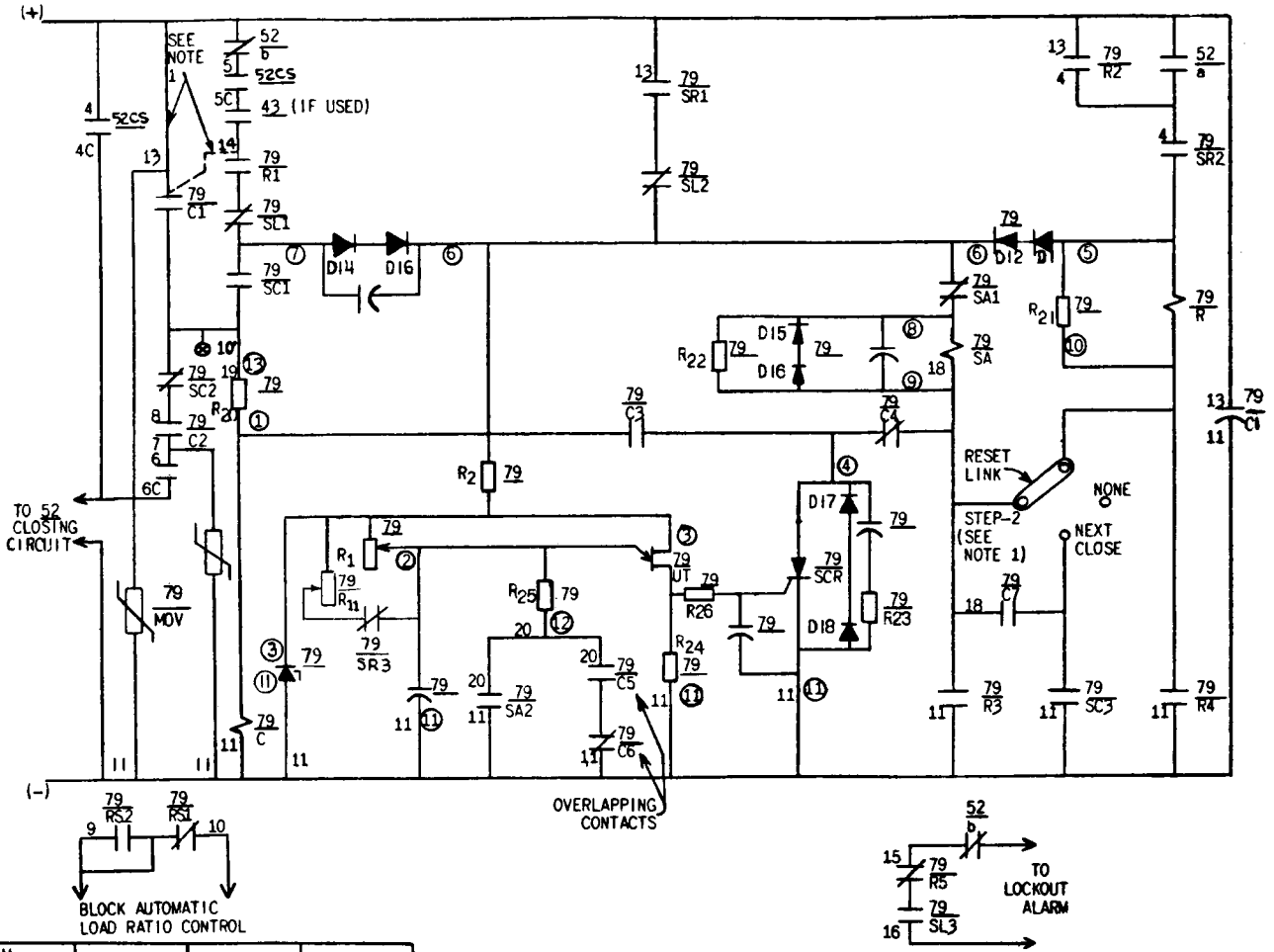

CAM OPERATED CONTACTS	RESET STEP #0	STEPS 1-34	LOCKOUT STEP 35
SL $\overline{1}$			X
SR $\overline{1}$	X		
SR $\overline{1}$		X	X
SL $\overline{1}$	X	X	
SC $\overline{1}$	X, ANY 3 NON-ADJACENT STEPS		
SC $\overline{1}$	OPEN WHEN SC $\overline{1}$ IS X		
RS $\overline{1}$	X IN ANY 6 ADJACENT STEPS		
RS $\overline{1}$	OPEN WHEN RS $\overline{1}$ IS X		

LEGEND			
DEVICE NO.	TYPE	INCL. ELEM.	DESCRIPTION
52CS	SB		CONTROL SWITCH
52			AC CIRCUIT BREAKER
79	NLR		AC RECLOSING RELAY
		C	CLOSING UNIT
		R	RESETTING UNIT
		RS	CAM OPER. AUX-FUNCTION SW.
		SA	ARMATURE OF STEPPING SW.
		SC	CLOSING CONTS. OF STEPPING SW.
		SL	LOCKOUT CONTS. OF STEPPING SW.
		SR	RESETTING CONTS. OF STEPPING SW.

BREAKER CONTROL SWITCH		MODEL 165810D920 STS2P		
W/LSCH 6302670-62		W/NP - 78898 - 6		
CONTACT NUMBER	CLOSE	NORMAL AFTER CLOSE	NORMAL AFTER TRIP	TRIP
1	2			X
3	4			X
5	6	X	X	
7	8	X	X	
9	10	X	X	

DESCR. OF DEVICE	INT. CONNS.	OUTLINE
NLR21T	0257A5053	K-6208272

⑥ - NUMBERS IN CIRCLES ARE TERMINAL POINTS ON PRINTED CIRCUIT CARD.

NUMBERS ON CONTACTS (79/R1, 79/SC1, ETC) ARE ARBITRARILY ASSIGNED FOR IDENTIFICATION PURPOSES.

Fig. 10. Typical external connections for the NLR21T reclosing relay providing a separately adjustable first-step time, dc supply (0108B8910)

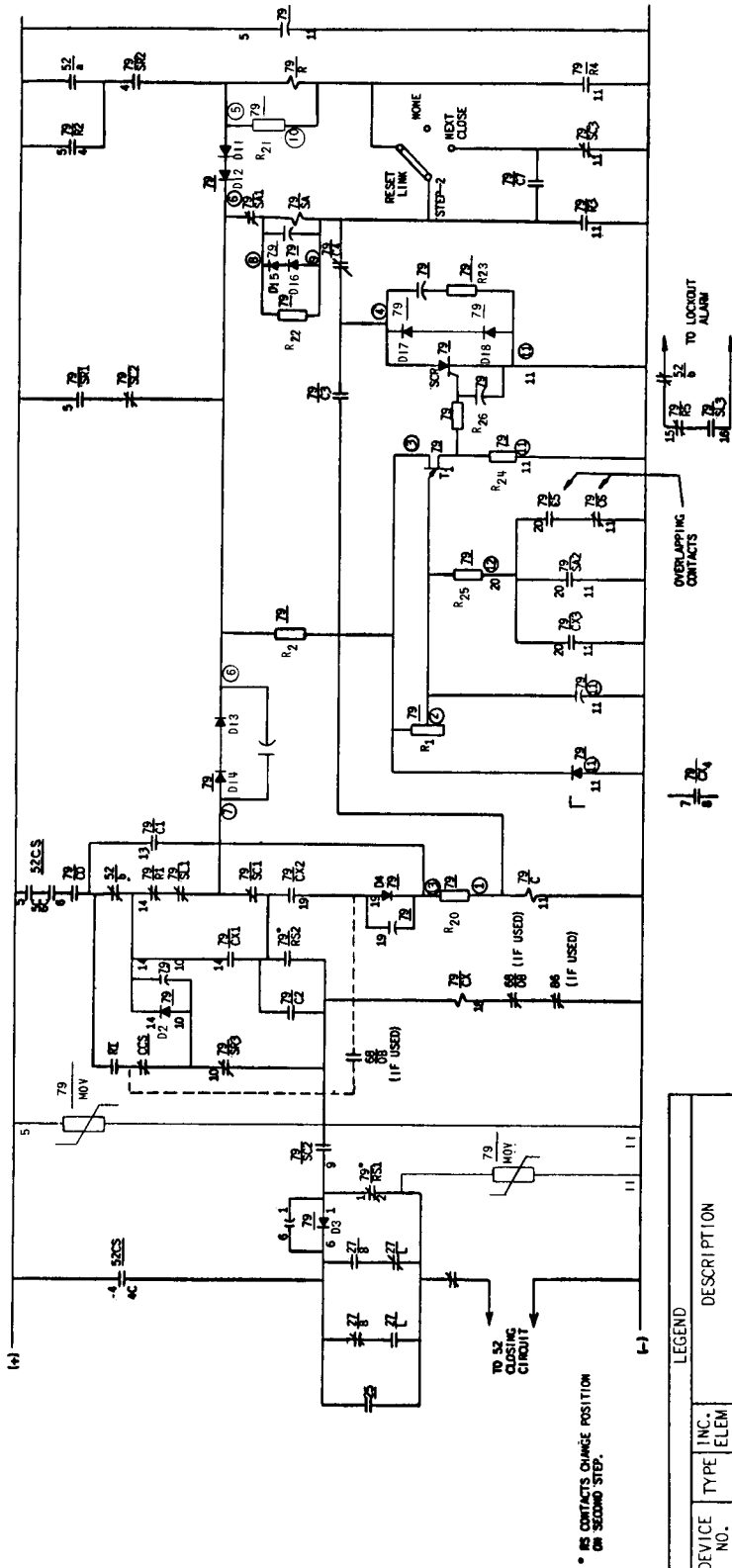

DEVICE NO.	TYPE	INC. ELEM	DESCRIPTION
R1			SELECTIVE RECLOSING (OPER. BY PRIMARY RELAYS)
25	IJS		SYNCHRONISM CHECK RELAY
27	NGV		VOLTAGE RELAY-BUS
27	NGV		VOLTAGE RELAY-LINE
52			CIRCUIT BREAKER
52CS	SB-1		CIRCUIT BREAKER CONTROL SWITCH
79	NLR		RECLOSING RELAY
	C		CLOSING UNIT
	CX		HOLDING UNIT FOR TIMER
	R		RESETTING UNIT
	RS		CAM OPER. AUX. — FUNCTION SW.
	SA		ARMATURE OF STEPPING SW.
	SC		CLOSING COILS. OF STEPPING SW.
	SL		LOCKOUT COILS. OF STEPPING SW.
	SR		RESETTING COILS. OF STEPPING SW.
79CO	SB-1		RECLOSING CUTOFF SWITCH
86	HEA		LOCKOUT RELAY
CCS	SB-1		CARRIER CUTOFF SWITCH

BREAKER CONTROL SWITCH — MODEL 16S81B12			
CONTACT NUMBER	NORMAL CONTACT CLOSED		
	CLOSE	NORMAL AFTER CLOSE	TRIP
1	1-1	1	X
2	1-2	2	X
3	1-0-1	3	X
4	1-0-1	4	X
5	1-0-1	5	X
6	1-0-1	6	X

DESCR. OF DEVICE	INT. CONNS.	OUTLINE
NLR21E(-)A	0216A3329	K-6209272

CAM OPERATOR CONTACTS	RESET. STEP NO. 0	STEPS 1-34	LOCKOUT STEP 35
SL	1-1		X
SR	1-1	X	
SL	1-1	X	X
SC	1-1	X	
SC	1-1	OPEN WHEN SC → F — IS X	
RS	1-1	X IN ANY → ADJACENT STEPS	
RS	1-1	OPEN WHEN RS → F — IS X	

⊙ — NUMBERS IN CIRCLES ARE TERMINAL POINTS ON PRINTED CIRCUIT CARD.
 NUMBER ON CONTACTS (79/R1, 79/SCI, ETC.) ARE ARBITRARILY ASSIGNED FOR IDENTIFICATION PURPOSES.

Fig. 11. Typical external connections for NLR21E reclosing relay, transmission line applications, dc control voltage, selective reclosing with synch check, out-of-step blocking (0165B2633)

Delayed Reclosures Following Immediate Reclosure

If the fault is permanent, the breaker will be retripped by the primary relaying and the RI contact will again close. A second immediate reclosure will be prevented because the CX unit has dropped out, and contact SR3 is open so the RI contact cannot pick up CX again. The NLR will now step to the first delayed reclosure point where a cam will open SC2 and close SC1. The SC1 contact will pick up CX through the RS2 contact, and closure of the CX contacts will pick up C which seals in. The CX3 contact will short out the timing capacitor thus preventing further operation of the step timer while CX is up. However, the C7-SC3 contact combination will energize SA, causing the switch to step once more to reclose SC2 and open SC1 and SC3. Closure of SC2 completes the closing circuit up to the synchronism check circuit (or live line/dead bus or live bus/dead line check). The NLR relay will wait at this point because CX will remain picked up. When the check circuits permit a reclosure, the CX unit will drop out permitting the timing circuit to commence functioning again.

Delayed Initial Reclosure

If the breaker is initially tripped by time-delay backup relays, the RI unit will not pick up. Closure of the "b" switch will start the timer, and diode D2 prevents CX from picking up and in turn operating C. On the first time step, SC1 and SC3 will open and SC2 will close. On the second time step, the RS contacts will reverse position.

When the first delayed reclosure position is reached, the cam will open SC2 and close SC1 and SC3. Closure of SC1 will pick up CX, since the RS2 contact is now closed, and this in turn will operate C. The sequence will now be the same as described in the previous section headed "Delayed Reclosures Following Immediate Reclosure", with the delayed

reclosure controlled by the synchronism check circuit.

Reset

Immediate reset following a successful reclosure is accomplished in the same manner as previously described for the NLR21A relay. The selection link can be set in either the STEP-2, NEXT CLOSE, or NONE position.

Out-of-Step Blocking

If the primary relays are allowed to trip on an out-of-step condition, many users elect to block high-speed reclosing. This can be accomplished by means of contacts of the OB auxiliary unit in the Type CEB12B or CEB51A relay (68 device), as shown in Fig. 11.

A normally closed contact of OB is connected in the CX coil circuit, and a normally open contact of OB is connected from the RI contact to the C unit coil circuit. When a swing enters the 68/MOB characteristic, the OB unit will operate, block the CX unit, and set up a circuit from the RI contact to the C unit. If the primary relays ultimately trip on out-of-step, the RI unit will pick up and operate C, which in turn will seal-in. The C7 contact will initiate an immediate step in the normal manner, opening SC1, SC3 and SR3, and closing SC2. There will be no reclosure since SC1 and SR3 will be open before SC2 closes, and CX has not operated.

When the line is cleared by the breaker, the OB unit will reset. However, this unit has a minimum dropout time of 4 cycles so there is ample time for the immediate step to take place opening SC1 and SR3. When these contacts are open, the CX unit is blocked even though the OB contact has reclosed.

The NLR will now proceed to operate as previously described in the sections on delayed reclosures. The delayed reclosure attempts will

be supervised by the synchronism check or live line/dead bus live bus/dead line check circuits.

On multi-breaker arrangements, such as ring bus or breaker-and-a-half, there will normally be a single Type OSB relay associated with a line, and separate reclosing relays for each of the two breakers with that line. There are sufficient OB contacts in the Type CEB12B or CEB51A to accomplish the functions shown in Fig. 11 for each breaker.

General Comments

If it is desired to operate the NLR21E relay scheme with selective reclosing but without synchronism check or live line/dead bus live bus/dead line check, it is merely necessary to connect terminal 9 of the NLR relay directly to the breaker closing circuit, omitting the check contacts and RS1. A primary trip which operates RI will then initiate an immediate reclosure, while delayed trips will initiate a delayed initial reclosure.

If it is desired to use the NLR21E relay without selective reclosing, omit RI and jumper terminals 10 and 14. Closure of 52/b will then initiate an immediate reclosure regardless of whether the trip was instantaneous or delayed. Such an arrangement would not normally be recommended on transmission lines, but might be needed if the NLR21E relay were to be applied on a stub-feed circuit.

Remote Breaker Control

When circuit breaker closing and tripping is from two or more locations, the use of control switch contacts such as 5-5C of 52CS shown in the various figures would not normally give the desired results. It is recommended that the 5-5C contact of 52CS be replaced by the contact of an auxiliary relay. One commonly used circuit is a

latched-type auxiliary relay which is picked up (and latches) by "trip" contacts of the two or more circuit breaker control switches and is unlatched by "close" contacts of the two or more breaker control switches; a contact which closes in the unlatched condition is used in place of 5-5C of 52CS in the circuits covered herein. Instead of a latched relay, similar results can be obtained by a single-coil, non-latching auxiliary relay which is picked up by an "a" contact of the breaker and seals itself around the breaker "a" contact; any breaker control switch operated to the trip position drops out the auxiliary relay. A normally open contact of the relay is used in place of 5-5C of 52CS.

When circuit breaker control is by supervisory control, a time-delay pick-up relay, connected as described above for the non-latching auxiliary relay, is recommended. The purpose of the time delay is to ensure that the breaker has been closed into an unfaulted line before setting up automatic reclosing.

TYPE NSR RECLOSING RELAYS

GENERAL

The Type NSR reclosing relay is designed to initiate a single high-speed reclosure of a power circuit breaker which has been tripped by protective relays. After the relay has initiated a successful breaker reclosure it will reset automatically in a predetermined adjustable reset time. The relay will lock out if the breaker should trip again during the reset time interval.

The basic relay circuit consists of a capacitor-resistor timing scheme with an associated auxiliary relay; unit. Hence, the relay is inherently suited for dc operation. Models are available, however, with an internal rectifier for operation from an ac source.

APPLICATION

The Type NSR reclosing relays are usually applied with transmission line circuit breakers where a single high-speed reclosure is desired, and where if this single reclosure attempt is unsuccessful, it is desired to lock out the breaker. The usual application of the relay is with line protective relays, either electromechanical or static, which include a reclosure initiation function (RI) to initiate the reclosure sequence when the primary protective relays operate. Relay models now available are listed in Table II.

Table II					
TYPE NSR RELAYS					
Type	AC or DC	Typical Voltage Ratings	Target	Typical Target Ratings	Remarks
NSR11C	AC	120/240, 60 Hz	No	—	
NSR11D	AC	120/240, 60Hz	Yes	0.1, 0.2 & 1.0A	
NSR21E	DC	48/125/250	No	—	
NSR21F	DC	48/125/250	Yes	0.1, 0.2 & 1.0A	
NSR21G	DC	48/125/250	No	—	Adjustable re-close time
NSR21H	DC	48/125/250	Yes	0.1, 0.2 & 1.0A	Adjustable re-close time

PRINCIPLES OF OPERATION

GENERAL DESCRIPTION

The basic operating elements of the Type NSR relay are a timing capacitor, a high-resistance rheostat, and a telephone-type relay having two electrically separate coils. The operation of these basic components to initiate a single immediate reclosure is illustrated by the simplified diagram in Fig. 12. Under normal conditions with the breaker closed, the capacitor will be fully charged. When the circuit breaker is tripped, the initiating contact will connect the operating coil of the telephone-type

relay (79/OC) across the capacitor. The capacitor will discharge through the operating coil, causing the unit to pick up and seal in by means of its holding coil (79/HC), and energize the breaker closing circuit through contact 79-1. Contact 79-2 will completely discharge the capacitor so that full reset time will be realized after each operation. When the breaker recloses, the 52Y contact (or equivalent) associated with the breaker closing circuit will open the holding coil circuit, and the unit will drop out.

If the breaker is reclosed successfully, the capacitor will immediately start to recharge. The reset time of the NSR relay is the time required for the capacitor to recharge to the point where its stored energy will be sufficient to pick up the telephone-type unit if the capacitor is again discharged through 79/OC. This reset time is adjustable over a range of 3 to 20 seconds by means of the high-resistance rheostat (79/RHEO) which is accessible from the front of the relay. If the breaker should retrip prior to the reset time, the stored energy in the capacitor will not be sufficient to operate the telephone-type unit and the NSR relay will lock out.

TYPICAL CONNECTIONS

The most common applications of the Type NSR relay is on transmission lines where a single high-speed reclosure is required. The elementary diagram in Fig. 13 shows typical external connections for such an application of the NSR21E or NSR21F with dc control voltage. The basic circuit elements described in the GENERAL section will be recognized. However, a number of refinements are shown on the detailed elementary which require explanation.

Under normal conditions, the timing capacitor will be charged through the 86 and 79 CO contacts. The capacitor voltage, when it is fully charged, is limited to 30 volts by the Zener regulator connected across the capacitor and

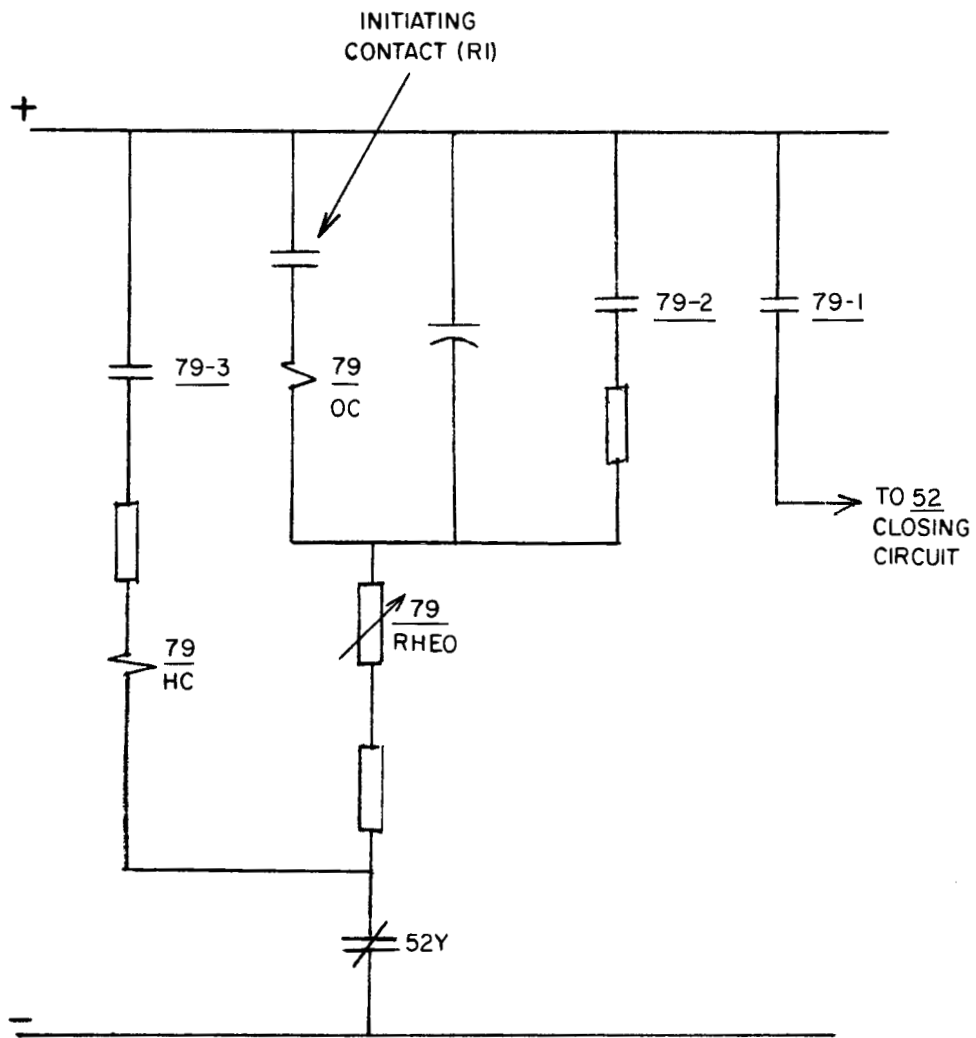

Fig. 12. Simplified diagram of NSR reclosing relay circuit

the rheostat. The regulator assures that the voltage across the capacitor-rheostat combination will be constant, and hence the reset time will be independent of variations in the supply voltage. In fact, the timing circuit is the same for dc voltage ratings of 48, 125, or 250. A selection link is provided for the holding coil circuit, however, to select the proper series resistor for 48,125, or 250 volts.

On typical transmission line breaker applications, high-speed reclosing is initiated by a contact of the reclosure initiating unit (RI), which in turn is operated by the high-speed primary pilot relaying. On directional comparison carrier schemes or transferred trip schemes, using electromechanical relays, the RI unit is in the associated Type NAA auxiliary relay. On static relay schemes, RI is in the associated Type SLA or SLAT auxiliary relay.

Closure of the RI contact will cause the capacitor to discharge through the operating coil (79/OC), via the CCS and 68/OB contacts and the diode (D2), causing the main closing unit to pick up and seal in by means of its holding coil (79/HC). Closure of the 79 unit contact (studs 1-2) will then energize the circuit breaker closing scheme, through a 52/b or 52/bd switch not shown on the typical diagram in Fig. 13. This arrangement of initiating the single reclosure by means of an RI unit makes it possible to distinguish between tripping by the pilot relaying, where a reclosure is desired, and by the backup relaying where a reclosure should not be initiated. Note that when the NSR21E or NSR21F is applied in this manner the green lead must be connected to terminal 8.

Another contact of 79 discharges the capacitor through the 47-ohm discharge resistor. As previously noted, this ensures that the timing capacitor will be completely discharged so that full reset time will be realized after each operation. Note that the 52/b contact also

provides a second discharge path through diode D3. This ensures that the capacitor will be discharged when the breaker is manually tripped, or is tripped by protective relaying that does not initiate a high-speed reclosure. The 52/b contact also performs the function of de-energizing the holding coil (79/HC) when the circuit breaker is reclosed. Some users may prefer to use a 52Y contact, associated with the breaker closing circuit, to open the holding coil circuit. Scheme diagrams covering this option can also be furnished.

On some circuit breakers, for example the General Electric Type ATB, the 52/b switch closes early in the opening stroke. The resistor in the circuit to terminal 8 of the NSR relay ensures that the 52/b contact will not discharge the capacitor before the RI contact has had a chance to operate 79/OC. The resistor has been selected to assure proper operation of the 79/OC circuit for an assumed extreme condition of RI and 52/b closing simultaneously.

If a 52Y contact is used to de-energize the holding coil (79/HC) and a 52/b contact is not available to discharge the capacitor, a contact of the control switch (52CS) should be used for this purpose. This contact should be closed in the TRIP position of the switch. Use of such a contact will discharge the capacitor following a manual trip of the circuit breaker and thus avoid the possibility of a close-trip-reclose sequence if the breaker is subsequently manually reclosed onto a fault.

On some transmission line applications, it is desirable to block reclosing in the event that the breaker is tripped by an out-of-step condition. The diagram in Fig.13 shows the use of contacts of the auxiliary unit OB in the out-of-step detecting relay 68 for this purpose. A normally closed contact of OB opens the circuit to the operating coil of the NSR relay, while a normally open contact is connected to discharge the

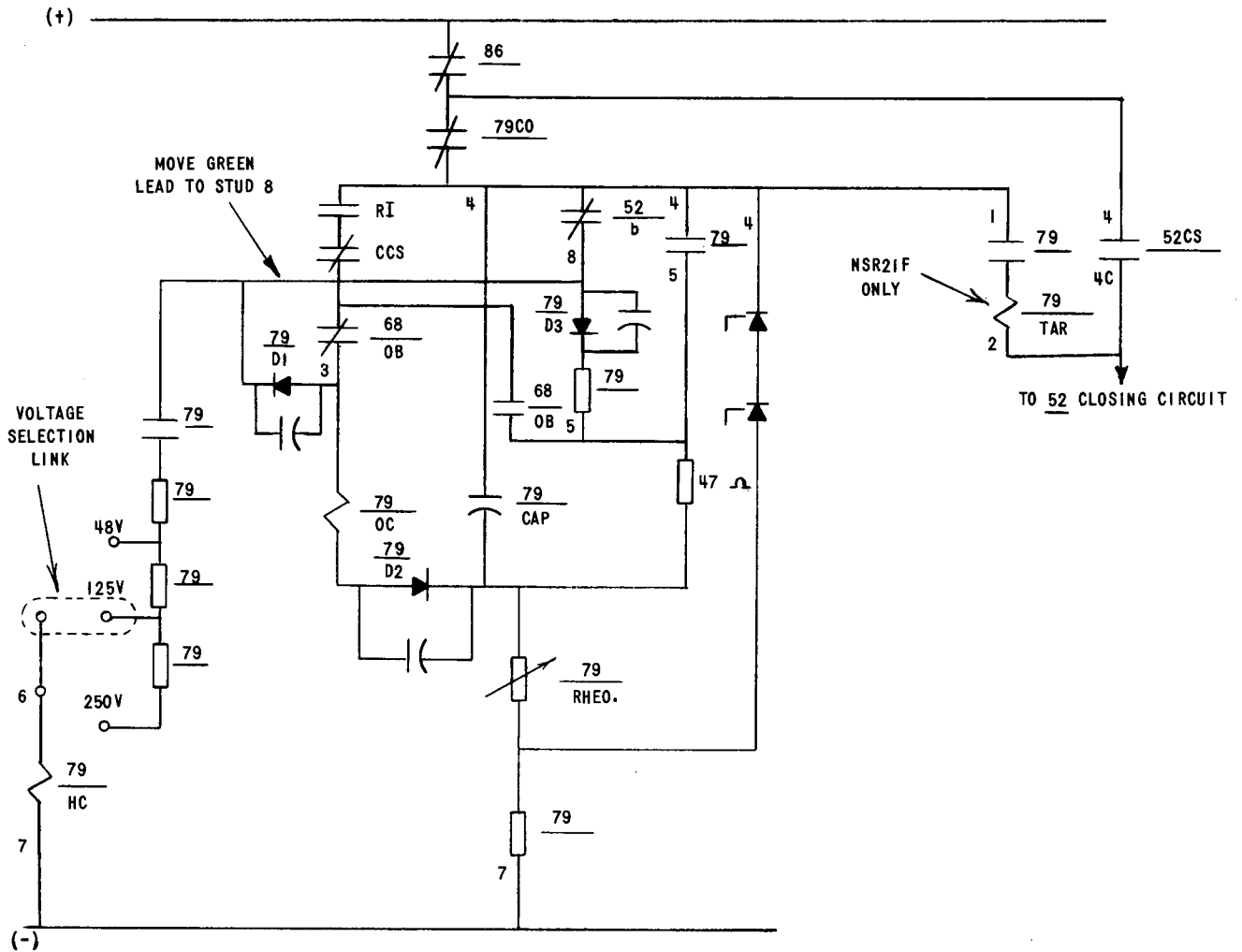

BREAKER CONTROL SW.
16SB1B9 X DENOTES CONTACT CLOSED

C CONTACTS HANDLE END		CLOSE	NOR AFTER CLOSE	NOR AFTER TRIP	TRIP
1 — — 2	1				X
1 — — 2	2				X
3 — — 4	3		X	X	
3 — — 4	4	X			
5 — — 6	5	X	X		
5 — — 6	6	X	X		

LEGEND		
DEVICE NO.	TYPE	DESCRIPTION
52CS	SB	CONTROL SWITCH
52		AC CIRCUIT BREAKER
79		RECLOSING RELAY
86		LOCKOUT RELAY (IF USED)
79CO		RECLOSING CUTOOUT SW.
RI		RECLOSING INITIATING UNIT
68/OB		OUT-OF-STEP BLOCKING RELAY
CCS		CHANNEL CUTOOUT SW.

Fig. 13. Typical external connections for Type NSR21E and NSR21F relays,
reclosure initiated by RI unit, dc control voltage only (0257A5095)

capacitor in the event that the RI unit is picked up by operation of the primary relaying on the out-of-step condition. Note that if the system recovers from the swing without the primary relaying and RI operating, the capacitor will not be discharged, and the high-speed reclosing circuit will be reinstated as soon as 68/OB drops out.

Where an RI function is not included as an integral part of the primary relaying, selective reclosing can be realized by using an externally mounted auxiliary unit in combination with a tripping rectifier to separate the instantaneous and time delay trip buses. The Type NGA15D relay, with appropriate pickup and dropout times, was designed specifically for this purpose.

Initiation by 52/b

On applications where a single high-speed reclosure is desired on any trip by protective relays, except bus or transformer differential, automatic reclosing should be initiated by a 52/b contact. The diagram in Fig. 14 shows the recommended connections. Note that with these connections, the green lead in the NSR relay internal wiring should be connected to terminal 3. With this connection the closure of the 52/b contact when the breaker trips causes the capacitor to discharge through the operating coil (79/OC), causing the main unit to pick up and seal in by: means of the holding coil (79/HC)

via the same 52/b contact. The 52/b contact which initiates the reclosure will also ensure discharge of the capacitor following a manual trip. The 79/OC coil will be energized momentarily, but the 3-5 contacts of the 52CS switch will be open so reclosing will be blocked and the holding coil will not be energized.

On some applications with transmission line circuit breakers it may be desirable to introduce a slight time delay into the reclosing sequence. The NSR21G relay includes a timer (0.5 to 3 or 10 seconds) for this purpose. The diagram in Fig. 15 shows typical external connections for the NSR21G when reclosure is initiated by the RI function in the pilot relaying scheme. The operation of this scheme is the same as described above for the NSR21E, except operation of the 79 contact now operates a timer, the output contact of which energizes the breaker closing circuit.

AC Control

The Type NSR11C and NSR11D relays with internal rectifier are designed for use where only ac control voltage is available. Typical external connections for these relays are shown in Fig. 16.

The diagram shows initiation of reclosure by means of a 52/b contact since this will usually be the case in the application area where ac control voltage is used.

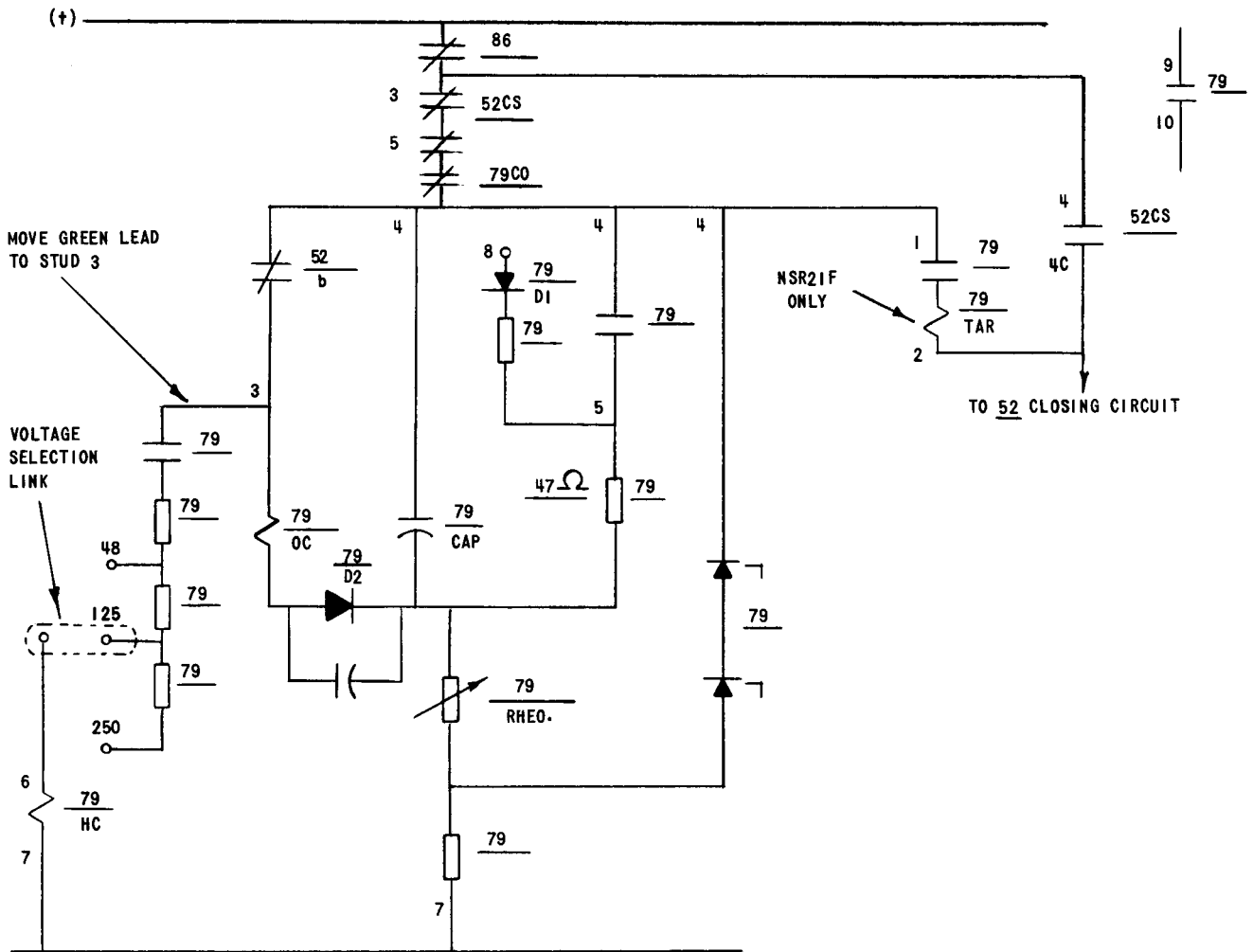

BREAKER CONTRL. SW. 16SBI89
X DENOTES CONTACT CLOSED

CONTACTS HANDLE END		CLOSE	NOR AFTER CLOSE	NOR AFTER TRIP	TRIP
1	2				X
	1				X
3	4		X	X	
	3	X			
5	6	X	X		
	5	X	X		

LEGEND		
DEVICE NO.	TYPE	DESCRIPTION
52CS	SB	CONTROL SWITCH
52		AC CIRCUIT BREAKER
79		RECLOSING RELAY
86		LOCKOUT RELAY (IF USED)
79CO		RECLOSING CUTOUT SW.

Fig. 14. Typical external connections for NSR21E and NSR21F relay, reclosing after any automatic trip, breaker control from one point only, dc control power (0257A5092)

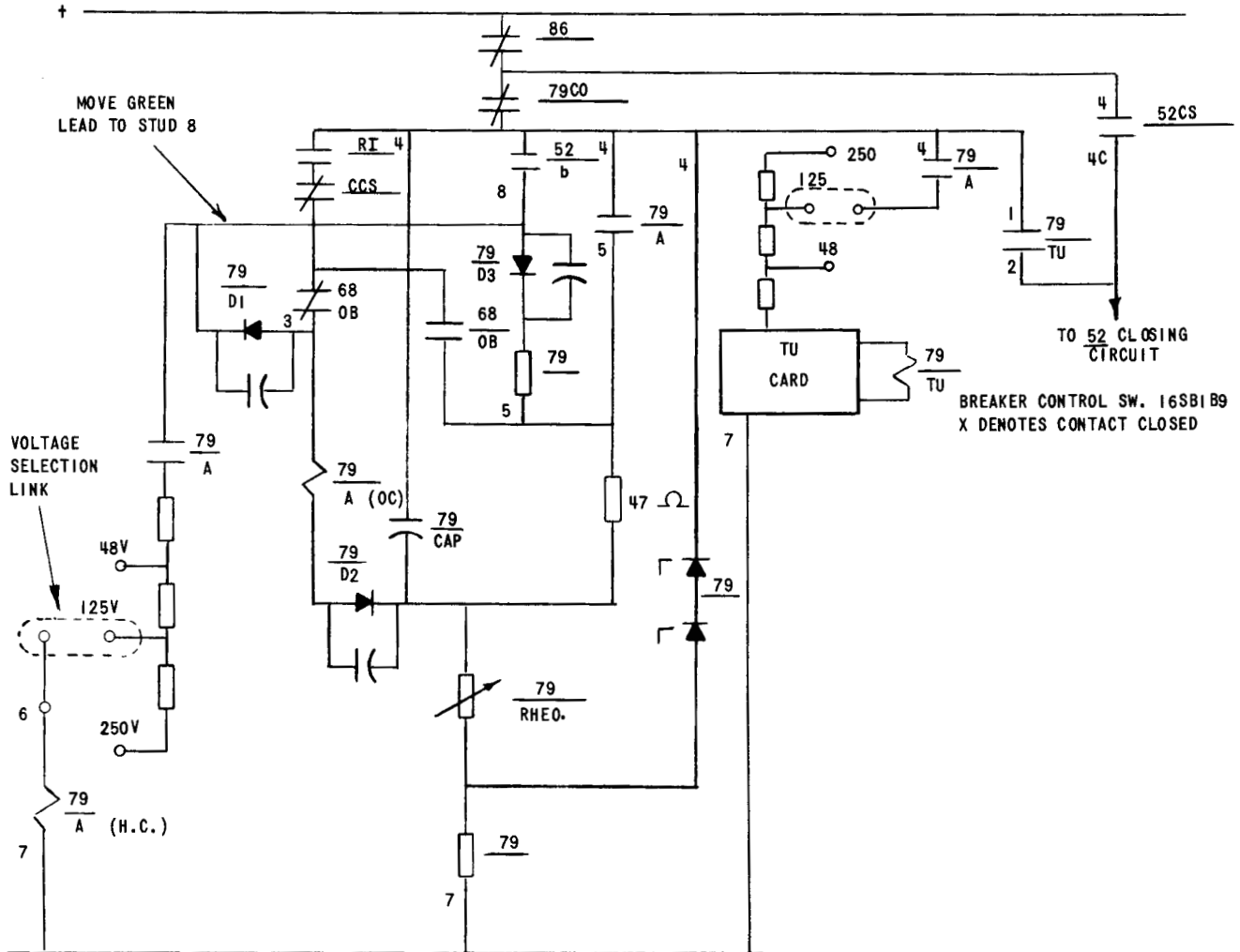

CONTACTS HANDLE END	CLOSE	NOR AFTER CLOSE	NOR AFTER TRIP	TRIP
1-2				X
3-4	X	X	X	
5-6	X	X		

LEGEND		
DEVICE NO.	TYPE	DESCRIPTION
52CS	SB	CONTROL SWITCH
52		AC CIRCUIT BREAKER
79		RECLOSING RELAY
86		LOCKOUT RELAY (IF USED)
79CO		RECLOSING CUTOUT SW.
RI		RECLOSING INITIATING UNIT
68/OB		OUT-OF-STEP BLOCKING RELAY
CCS		CHANNEL CUTOUT SW.

Fig. 15. Typical external connections for NSR21G relay, reclosure initiated by RI unit, dc control voltage (0257A5093)

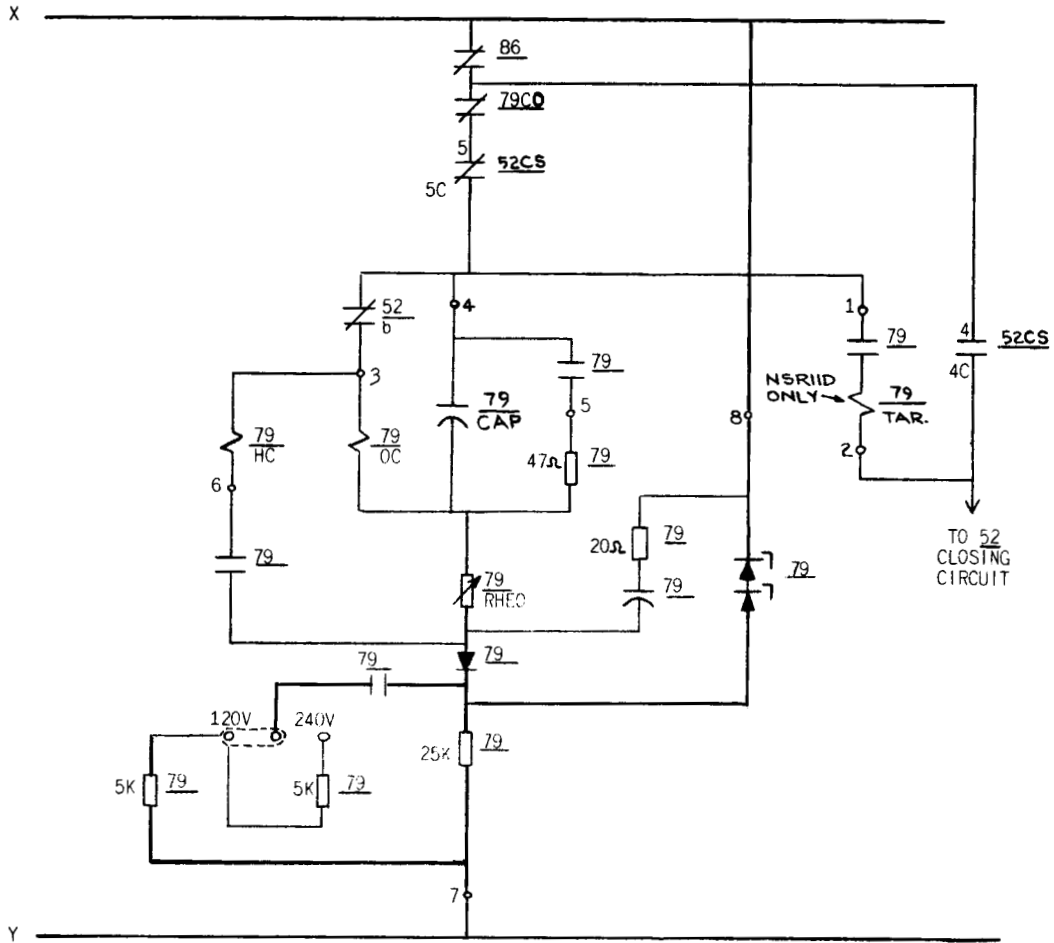

DESCR. OF DEVICE	INT. CONN.	OUTLINE
NSR11C1A	0178A9191	6209271
NSR11D1A	0178A9177	6209271

BREAKER CONTROL SW. 16SB189
X DENOTES CONTACT CLOSED

CONTACTS HANDLE END	CLOSE	NOR AFTER CLOSE	NOR AFTER TRIP	TRIP
1-2				X
2-3				X
3-4		X	X	
4-5	X			
5-6	X	X		
6-7	X	X		

LEGEND		
DEVICE NO.	TYPE	DESCRIPTION
52CS	SB	CONTROL SWITCH
52		AC CIRCUIT BREAKER
79		RECLOSING RELAY
86		LOCKOUT RELAY
		STUDS ON NSR RELAY
79CO		RECLOSING CUTOUT SW.

Fig. 16. Typical external connections for NSR11C and NSR11D relays, reclosing initiated after any automatic trip, breaker control from one point only, ac control power (0165B2206)



GE Power Management

215 Anderson Avenue
Markham, Ontario
Canada L6E 1B3
Tel: (905) 294-6222
Fax: (905) 201-2098
www.GEindustrial.com/pm