



TEST INSTRUCTIONS

GEK-7309C

TEST INSTRUCTIONS FOR INSTALLATION OR SERVICE OF

POWER SENSOR* TRIP DEVICE

**Used on Type AK Low-voltage
Power Circuit Breakers**

*Registered Trademark of General Electric Company

GENERAL  **ELECTRIC**

POWER SENSOR TRIP DEVICE

Used on AK Type Low Voltage

Power Circuit Breaker

OBJECTIVES

This instruction book is intended to serve as a supplement to the Maintenance Manuals for Low Voltage Power Circuit Breakers, and the Instructions for the Power Sensor Test Set, GEK-7301, used to check the Power Sensor trip device. It is meant to be used by GE I&SE, GE service shop, OEM, and contract tester personnel as an aid in installing AK type breakers equipped with Power Sensors, and as an aid in locating the problem area when a particular breaker is being serviced.

GENERAL INFORMATION

Before attempting any checks or adjustments, the tester must consult the maintenance manuals for the breaker to familiarize himself with the operating details of the specific breaker involved and the Power Sensor overcurrent trip device. He should disconnect the breaker from the primary power bus. Prior to checking the trip device the breaker contacts should be inspected and the mechanism and trip latch should be checked for proper functioning to verify that the breaker can suitably carry the required current. The trip shaft should be free of high friction loads. The trip latch should be checked for proper trip latch engagement and torque.

The Power Sensor trip device employs a peak reading circuit and responds to the magnitude of current in the primary phase carrying the largest current. Therefore, a non-sinusoidal current may result in what appears to be an erroneous operation of the Power Sensor system if RMS meters are used to measure the non-sinusoidal signal and the trip device responds to the peak of the signal. The peak and the RMS value of non-sinusoidal signals are not related as they are for perfect sine waves.

In high current, low voltage test circuits one of the major causes of waveform distortion is the non-linear breaker impedance. To maintain a reasonably sinusoidal current waveshape, air core reactance equal to approximately 20 microhenries should be inserted in the test circuit in series with the breaker for AK-25, 75 and 100 breakers. (No reactance is needed for AK-50 breakers unless it is rated 200-600A.)

This reactance is not needed when operating from the power system because the current is produced by a source with sufficient voltage to maintain a sinusoidal current waveform. The

output current of a high current-low voltage test set which uses a variable voltage transformer will follow the primary voltage. The current may not be sinusoidal, when the Power Sensor trip device is its load, due to the reduced voltage at the zero crossing of the current waveform. Air core reactance shifts the phase angle between the voltage and current so that at current zero the voltage will be large enough to maintain the rate of change of current needed for a sinusoidal current waveform.

Some problems may occur while testing logic units removed from breakers stored in high humidity areas. The test results may become erratic and not agree with published curves and tolerances. This can be due to a high moisture content on the surface of the logic unit's circuit boards in de-energized equipment.

This test problem has been solved by removing the logic units to a warm dry area for about an hour prior to testing. Once the breaker is carrying current, the normal elevated temperature within its compartment is enough to eliminate the effects of this high humidity environment.

Additional information that should be available during test includes:

1. Drawings #133C9017, #133C9018 and #138B2454 on pgs. 10, 11, and 12.
2. GEK-7301 - Power Sensor Test Set Instructions.
3. GEK-7303 - Breaker Maintenance Manual (AK-3-50/75/100)
4. GEK-7310 - Breaker Maintenance Manual (AK-5-50)
5. GEI-50299 - Breaker Maintenance Manual (AK-25).
6. GEZ-4431 - Packet of Time Current Curves.

INSPECTION

Check the following items against the specified settings for the particular breaker application when they apply.

1. The sensor CT taps should be set at the correct current rating on all three phases. These taps must be secure. The Power Supply rating disc should also be set to the correct current rating. (See Figure 1 and Figure 3).

These instructions do not purport to cover all details or variations in equipment nor to provide for every possible contingency to be met in connection with installation, operation or maintenance. Should further information be desired or should particular problems arise which are not covered sufficiently for the purchaser's purposes, the matter should be referred to the General Electric Company.

To the extent required the products described herein meet applicable ANSI, IEEE and NEMA standards; but no such assurance is given with respect to local codes and ordinances because they vary greatly.

2. The tap selector knobs on the Power Sensor unit should be set to the correct pickup and time delay settings for the application intended. These knobs must be secure. (Figure 2)
3. The magnetic trip device must be connected to the terminal block on the power supply. (Figure 3)
4. Check that both plug connections are secure. (Figure 3).

ON SITE POWER SENSOR SYSTEM CHECK
(High Current-Low Voltage Tests)

The check-out of AK type Power Sensor breakers at the time of installation includes a visual inspection as shown under the section titled "Inspection", page 4.

In some cases an on the site check of the breaker under overcurrent conditions is necessary. The purpose of overcurrent testing of trip devices in the field should be to determine if the breaker

will perform as required for the circuit to which it is connected. A Power Sensor test set, type PST-1, can be used to check all operations of the system except the breaker mounted CT's which can be checked for continuity with an ohmmeter.

Since the CT's are checked at numerous points during the assembly process, a continuity check showing that the resistance of the CT on one pole agrees with the resistance of the similar CT on the other two poles is sufficient.

When performing single phase checks on the ground fault equipped breakers, it is necessary to short terminals one and five at the ground signal terminal board on the back frame of the breaker. Shorting of the ground signal must be a high integrity connection since voltages in the range of .25 volt peak will cause operation of the ground fault circuit. Terminals one and five can be identified by the .15 micro-farads capacitor connected between them. (See Figure 4)

The following equipment will be necessary to make overcurrent tests:

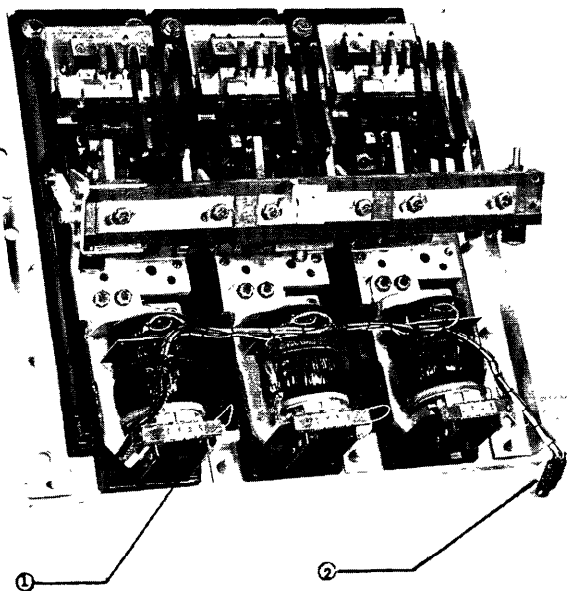

Figure 1. (8041487) Backframe for AK-3-50 Breakers showing Coil Assembly

1. Sensor CT taps
2. Disconnect plug

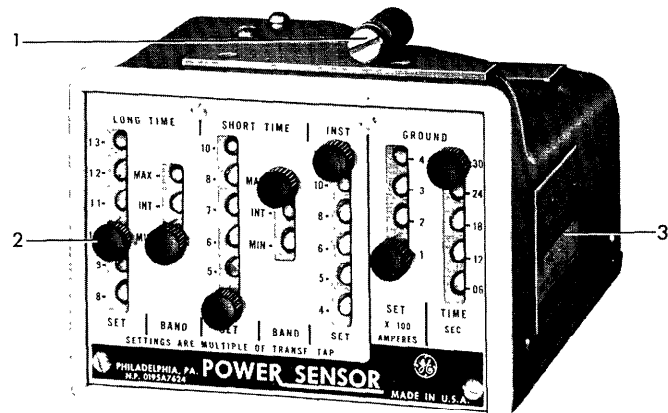

Figure 2. (8039649) Power Sensor Unit

1. Mounting Screw
2. Tap Selector Knobs
3. Name Plate

1. A high current-low voltage test set and a suitable timer.
2. A type PST-1 test kit.
3. A Volt-ohm-milliammeter (in good calibration).
4. A 20 micro-henry air core reactor, (For ground pick-up test).

CAUTION

THE POWER SENSOR TRANSFORMER TAP SELECTORS MUST BE CONNECTED AT ALL TIMES ON ALL PHASES. THE DISCONNECT PLUG CONNECTING THE FRONT FRAME WIRING TO THE BACK FRAME WIRING MUST BE CONNECTED BEFORE ENERGIZING THE POWER CIRCUIT. FAILURE TO ENSURE CONNECTIONS WILL RESULT IN DAMAGE TO THE COILS.

Adequate overcurrent testing at installation would include one overcurrent trip on each pole of the breaker using the lowest set function that has been supplied on the particular Power Sensor system. On breakers equipped with the Ground function a Ground trip test should also be performed. The suggestion to alternate the pole of the breaker used in the test is made to ensure that the output of each breaker mounted CT is tested. For example, a Power Sensor system supplied with Long Time Delay, Short Time Delay, and Ground Fault detection could be tested at its Long Time Delay setting, as received, on each pole of the breaker and at its Ground Fault setting as received.

The following methods can be used in making the appropriate test at installation. Included are:

- Long Time Delay Test - Timing or,
- Short Time Delay Test - Pickup or,

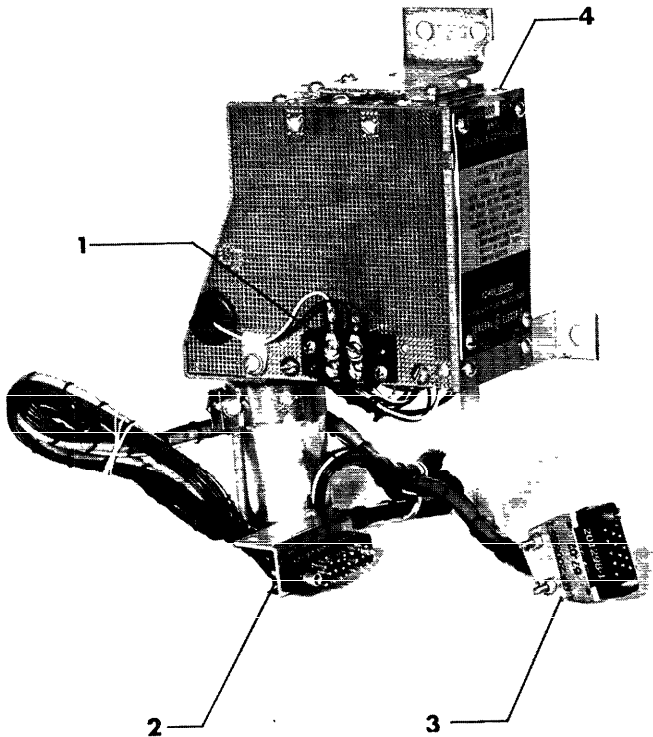

Figure 3A. (8041488) Power Supply AK-50, 75 and 100 Breakers

1. Terminal Block
2. Male Disconnect Plug
3. Female Disconnect Plug
4. Rating Disc

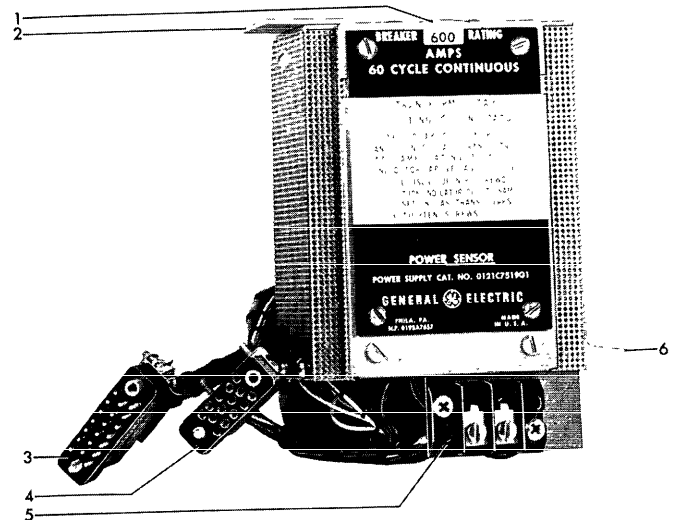

Figure 3B. (8039850) Power Supply AK-25

1. Rating Disconnect
2. Mounting Bracket
3. Male Disconnect Plug
4. Female Disconnect Plug
5. Terminal Block
6. Mounting Bracket

Instantaneous Trip Test - Pickup and,
Ground Fault Detection - Pickup, if included.
100 Volt Bus Test

LONG TIME DELAY TEST - TIMING

Power Sensor Settings:

LTD set for the particular breaker application.
All other trip functions set to maximum settings.

With the test truck connected to one pole of the breaker, apply test current equal to some convenient multiple of the CT tap setting. 300% of the CT tap setting is suggested because this one test point is adequate to ensure proper operation of the trip device. The trip times at this

test point are not too long and the test currents do not result in severe duty to the test equipment. (It must be remembered that repeated testing at high multiples of the continuous current rating will cause heating of the breaker contacts, and increased contact wear.)

Trip time at 3X current as found on the time current curves is:

MIN = 25 sec \pm 20%, INT = 75 sec \pm 20%
MAX = 150 sec. \pm 20%. The (X) is in multiples of the CT tap setting and is independent of the LTD pickup setting on the logic unit.

The LTD circuit operates so that the trip

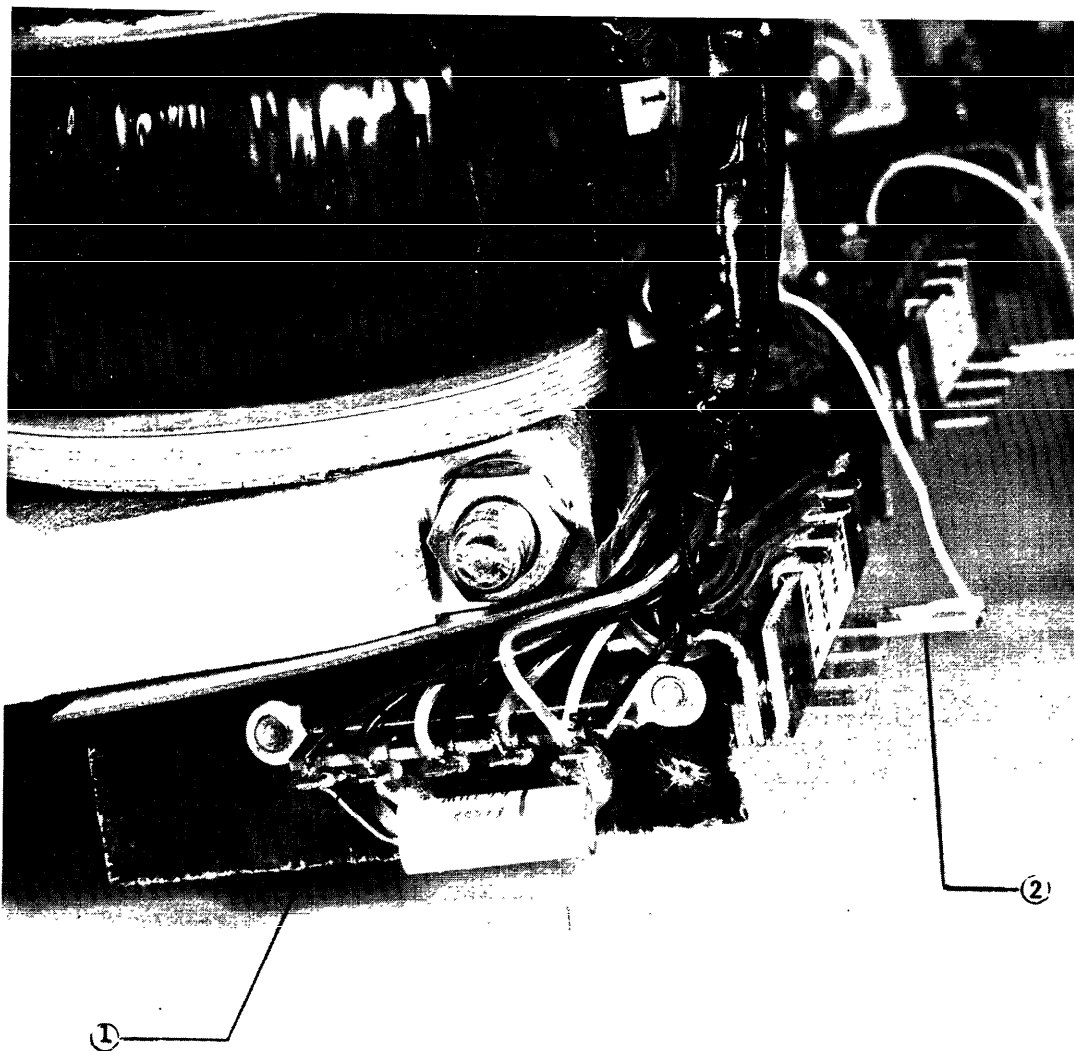

Figure 4 (8041489) Ground Signal Terminal Board (AK-3-50 shown).

1. Terminal Board

2. Sensor CT taps

time is equal to a constant divided by the current squared, $t = K/I^2$. A small variation in the actual test current ($\pm 5\%$) could, therefore, result in a $\pm 10\%$ additional variation in time.

The breaker should trip within the time band specified in the appropriate time-current curve when the comments in the above paragraph are considered. Repeat this test on the two remaining poles of the breaker.

NOTE: When testing AK-75 and AK-100 breakers it has been found that tests using the 1500A or 2000A CT tap are more convenient to make. No compromise in timing results will occur. (remember to return all pick-up and CT tap settings to the setting specified for the particular breaker application.)

SHORT TIME DELAY TESTS - PICKUP

If the breaker is not equipped with LTD but is equipped with STD, a test at 110% of the STD pickup setting is adequate to insure proper operation. (If timing is to be checked, use 200% of the pickup setting to avoid the "knee" of the time current curve).

Power Sensor Settings:

STD set for the particular breaker application. All other trip functions set to maximum settings.

With the test truck connected to one pole of the breaker apply test current equal to 110% of the Short Time pickup setting. Observe that the breaker trips. Repeat this test on the two remaining poles of the breaker. Test current should be raised slowly until tripping occurs so that the tester can make note of the trip current level.

INSTANTANEOUS TRIP TESTS

If the breaker is equipped with LTD or STD it is not necessary that the Instantaneous function be tested at the time of installation. If it is desired to test the Instantaneous function it is important that the STD pickup setting be set above the Instantaneous trip setting or the breaker will open at the STD setting before the Instantaneous setting is reached. (There is a noticeable difference between the trip time for a breaker which opens at the STD MAX time setting and one that opens at the Instantaneous trip level. This difference in time will allow testing of overlapping settings such as 12X CT tap setting when the STD is set to 10X. This is not the normal method of testing the Instantaneous function.)

Power Sensor Settings:

STD set above the Instantaneous setting. Instantaneous set to 4X. All other functions set for the particular breaker application.

With the test truck connected to one pole of the breaker apply test current equal to 110% of the Instantaneous pickup setting. Observe that the breaker trips. Repeat this test on the two remaining poles of the breaker. Test current should be raised slowly until tripping occurs so that the tester can make note of the trip current level.

The 4X setting is suggested for this test because at higher current levels repeated testing can result in heating of the breaker contacts and increased contact wear.

GROUND FAULT TESTS

Remove the jumper between terminals one and five. (On four wire systems only, place the jumper so that it simulates a short on the fourth wire CT. This jumper should be placed between the white lead and black lead of the twisted shielded pair at the disconnect plug.) Perform a continuity check as described on drawing 138B2454, page 12 of this manual.

Power Sensor Settings:

All functions should be set for the particular breaker application.

With the test truck connected to one pole of the breaker, raise the current slowly and note the level at which the breaker trips. Compare this level with the trip setting. Trip current should be within -20%, + 0% of the set point, however, the ground sensing function is sensitive to the rate of change of current and ground tripping that does not vary more than -30%, +10% from the setting should be considered acceptable. Repeat this test on the two remaining poles of the breaker.

On completion of these tests, remove any temporary jumpers. Perform a continuity check on the Ground circuit using drawing 138B2454. This can be done by disconnecting the 14-socket plug at the Power Sensor Unit, opening the breaker, and racking the breaker to the CONNECT position. Use an ohmmeter to perform a continuity check from point A to C, the circuit contains the ground sensor coils in series and should be continuous. Check continuity from A to R, an open circuit must appear.

The shielding must be continuous and can be checked on 4-wire systems by placing a temporary jumper at the 4th wire CT (in the neutral bus) from the black wire to the shield. With this jumper in place, continuity should exist between C and R when checked at the Power Sensor plug. Remove the jumper at the 4th wire CT, check at the plug for an open circuit between C and R. This establishes continuity of the shield from the plug to the 4th wire CT. On three-wire systems continuity of the shield can be checked by going from R at the plug directly to the shield at each Ground sensor CT.

Before the breaker is placed in service, the sensor CT taps must be set to the correct rating on all three phases. The tap selector knobs on the Power Sensor unit must be correctly set for the particular breaker application, and all disconnect plugs should be connected. Failure to ensure connections will result in damage to the coils.

Polarity of the ground sensor CT should be checked on 3-wire and 4-wire systems to make sure that the white polarity mark on the CT, near the position where the leads are connected, is away from the source in the standard breaker connection. (On reverse fed breakers the 4th wire CT should be installed so that the white polarity mark is toward the source.)

100 VOLT BUS TEST

This test can be performed in one of two ways: (a) using a high current test or (b) using the Power Sensor test set.

When using the high current, you must pass at least 30% of the breaker maximum current rating. This must be done on each phase. Close the breaker. With a d.c. Voltmeter, check for 100 volts d.c. at terminals of 110 mfd. Electrolytic Capacitor. The voltage must lie between the tabulated values on page 8. This Capacitor is located on the bottom of the Power Sensor power supply on large frame breakers, or the bottom left corner of the back frame on AK-3A-25 breakers. Instructions for using the test set to perform this check are in Instruction Book GEK-7301.

SERVICING OF AK POWER SENSOR BREAKERS

When a Power Sensor equipped low voltage circuit breaker is suspected of improper operation, it will fall into one of the following three classes: breaker fails to open, breaker fails to close, or breaker opens when it should not do so. It is important to first ascertain that the malfunction is caused by the Power Sensor System. Mechanical interlocks, intermittent secondary disconnects, sneak shunt trip circuits, or inadvertent acts by personnel must be removed as a possible cause of the problem.

Shown below and outlined in Chart I are the steps recommended for locating the faulty item.

IF THE BREAKER WILL NOT OPEN

Perform high current-low voltage tests as described under "On Site Power System Check" on page 3 of this manual. Proper operation during this test should direct the tester's attention to the power system and the breaker enclosure. Check the power system load for any unusual conditions that could be misinterpreted by the Power Sensor. Check the breaker enclosure.

For analysis of distribution system problems in special situations a Load Analyzing Test Cable is available for use by qualified General Electric Company personnel. (Catalogue number 152C2748). This cable presents the pins in the connection

plug between the power supply section and the logic unit, shown on drawing 133C9018, Figure 7 page 11, so that the actual output of the CT's and the power supply can be displayed on an oscilloscope while the circuit breaker is in service.

If the power system and breaker enclosure check okay or if there is no operation during the high current-low voltage tests, check the breaker trip shaft for binds, check all trip paddles for correct alignment, and check all shunt trips and lockouts for misalignment or incorrect settings. Refer to maintenance manuals GEK-7303 and GEI-50299 for instructions. Mechanically check the shunt trip and Power Sensor solenoid trip devices to assure a successful tripping operation just before the armature reaches the fully closed position, manually push the armature toward the closed position and determine how much further the armature moves after the breaker has tripped. This check to assure "positive trip" is within the tolerance specified in the breaker maintenance manual is important.

If all shunt trips and lockouts are correctly set and aligned, perform a continuity check on the Power Sensor CTs. Refer to Drawing 133C9017 or 133C9018 on pgs. 10, 11 of this manual. Measure resistances of similar coils on adjacent poles. Generally, if resistances balance the coils are good. For exact resistance values contact the factory. A satisfactory check of the CTs at this point would indicate an open Power Sensor connection plug or a problem with the Power Sensor itself. Use the Power Sensor test set and publication GEK-7301 and perform the described A and B Tests. The A Test will isolate the problem to the Power Sensor logic unit. The B Test will identify a power supply, trip relay, or cabling problem. Replace any section found defective by these tests. If no trouble is found, call the factory for further assistance.

IF THE BREAKER WILL NOT CLOSE

Check the equipment interlocks for interference. Check the trip shaft for binds, check all trip paddles to assure that they are properly aligned. Check all shunt trip devices and all lockouts. Misaligned or improperly set lockouts will prevent the breaker from closing resulting in trip free operation. If the above checks are successful, check the closing mechanism of the breaker according to the breaker manual.

IF THE BREAKER OPENS WHEN IT SHOULD NOT

If the breaker is equipped with ground fault protection, determine whether the false tripping is the result of falsely answering an overcurrent trip or a ground trip signal. This may be determined by temporarily eliminating the ground trip function by shorting points one and five at the ground signal terminal board on the back frame of the breaker. Terminals one and five can be identified by the .15uf capacitor connected between them. (See drawing 138B2454, and Figure 4). With the breaker restored to

service and with the ground fault detector deactivated, establish whether there is false tripping due to phase currents. If the ground trip function is at fault check the connection of the ground sensor coils and the polarity indications according to the wiring diagram 138B2454, page 12.

Perform high current-low voltage tests as described under "On Site Power Sensor System Check" Page 3 of this manual. In this case, it is necessary to test all functions that are supplied with the unit set to the setting for the particular breaker application. Proper operation during this test should direct the tester's attention to the power system and load to determine if actual problem conditions exist.

If improper operation persists, check the alignment of the trip shaft, trip paddles, shunt trips and lockouts. Correct any misalignment or binds. Check the CT taps on the sensor CT tap selector board at the coil assembly to make sure they are connected and securely set at the correct ampere rating. Recheck the ground coil wiring.

Check all plug connections according to 133C9017 or 133C9018 on pgs.10 and 11 of this manual. If open, check for damage and check continuity at both plugs. Change the appropriate section to replace the defective plugs. If the plug connections are secure, use publication GEK-7301 to perform the test designated A - test for the Power Sensor System. If the logic unit is bad, replace the logic unit; if good, perform the B test. With the Circuit Breaker open, set the

"Signal Adjust" knob fully counter clockwise for a minimum level. Push Electrical "Reset" Push Button and push "Start" Push Button.

With a d.c. Voltmeter, check for 100 volts d.c. at terminals of 110 mfd. Electrolytic Capacitor. This capacitor is located on the lower left corner of the backframe next to the CT disconnect plug on AK-3-25 breakers. On the AK-3-50/75/100 breakers, it is located on the bottom of the Power Sensor power supply. Measure this voltage on phase A, phase B and phase C by rotating the selector knob. If the voltage does not lie between the tabulated values, the power supply is defective and should be replaced.

POWER SUPPLY CATALOG NUMBER		PERMITTED D.C. VOLTAGE RANGE
AK-25	AK-50/75/100	
121C7519 G1	121C7521 G1	95 - 115
156C4508 G1	152C9262 G1	95 - 115
156C4508 G10	152C9262 G10	92 - 106

A defective system test at this point indicates a bad power supply section. Replace the power supply.

Once the trouble has been located and corrected using this method, the breaker should be placed in the test position and then opened and closed either manually or electrically. Proper operation will indicate that the problem condition has been corrected. Perform the inspection check as indicated on page 2. The breaker can now be placed in service.

TABLES AND CHARTS

1. Trouble shooting and service diagram, Figure 5, Chart I
2. Power Sensor Cabling Diagram Drawing #133C9017 (Figure 6) and #133C9018 (Figure 7)
3. Ground Fault System wiring drawing #138B2454 (Figure 8)
4. Time delay ranges for the Long Time Delay Circuit (GEK-7301 page 5).
5. Time overcurrent curves (Packet GEZ-4431).

QUICK CHECK LIST

1. Power Supply Rating disc is set at the correct current rating.
2. Coil taps are set at the correct current rating on all three phases.
3. Tap selector knobs on the Power Sensor Unit are set correctly.
4. All Power Sensor plugs are secure.
5. Shunt trip devices are correctly aligned to contact the trip paddles.
6. Wiring of Ground fault detection CTs, including the fourth wire CT, agrees with drawing #138B2454.
7. Power supply Output is between tabulated numbers above.

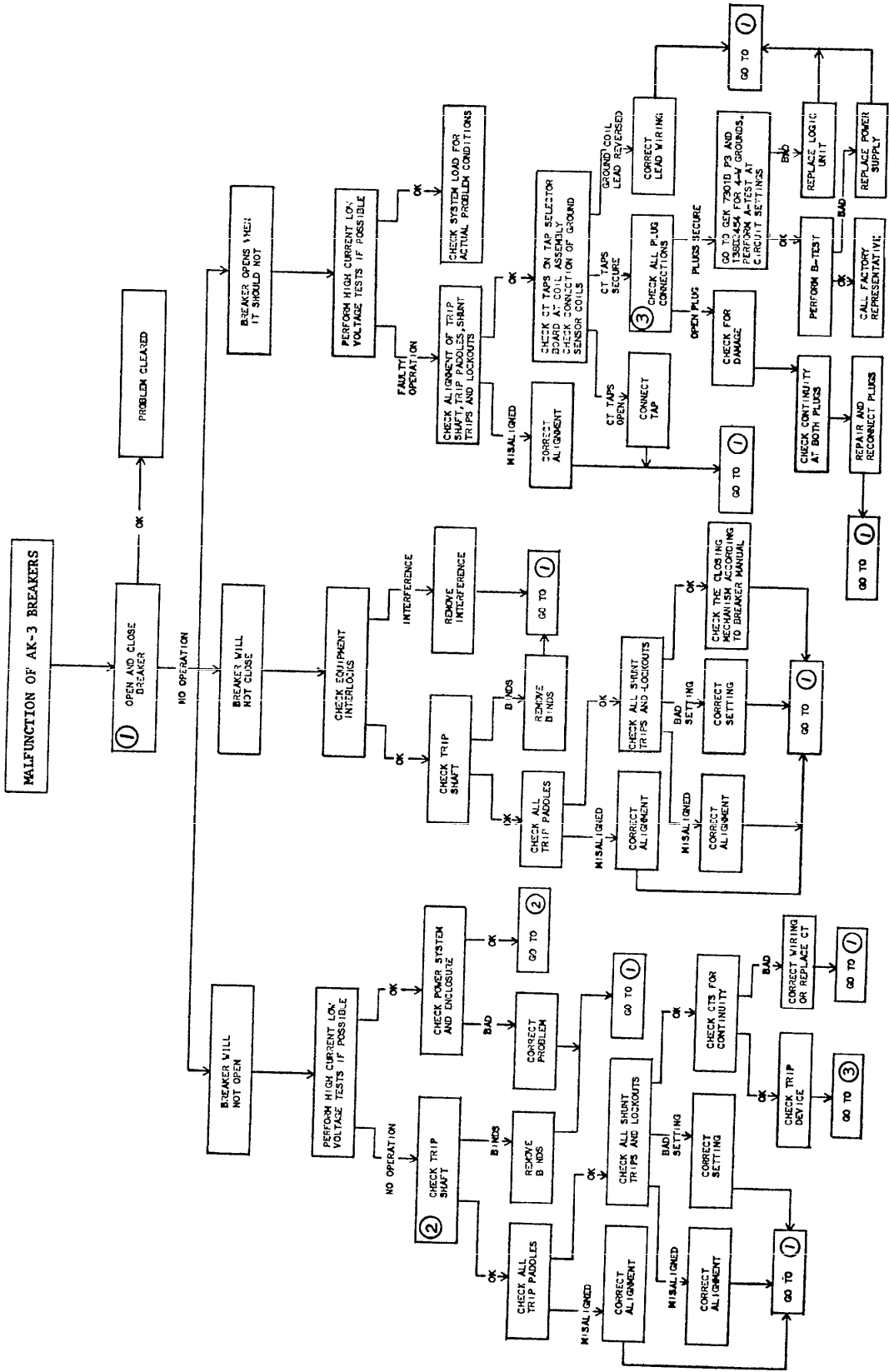

Figure 5. Chart I - Trouble shooting and service diagram.

AK-3-25
POWER SENSOR TRIP CABLING

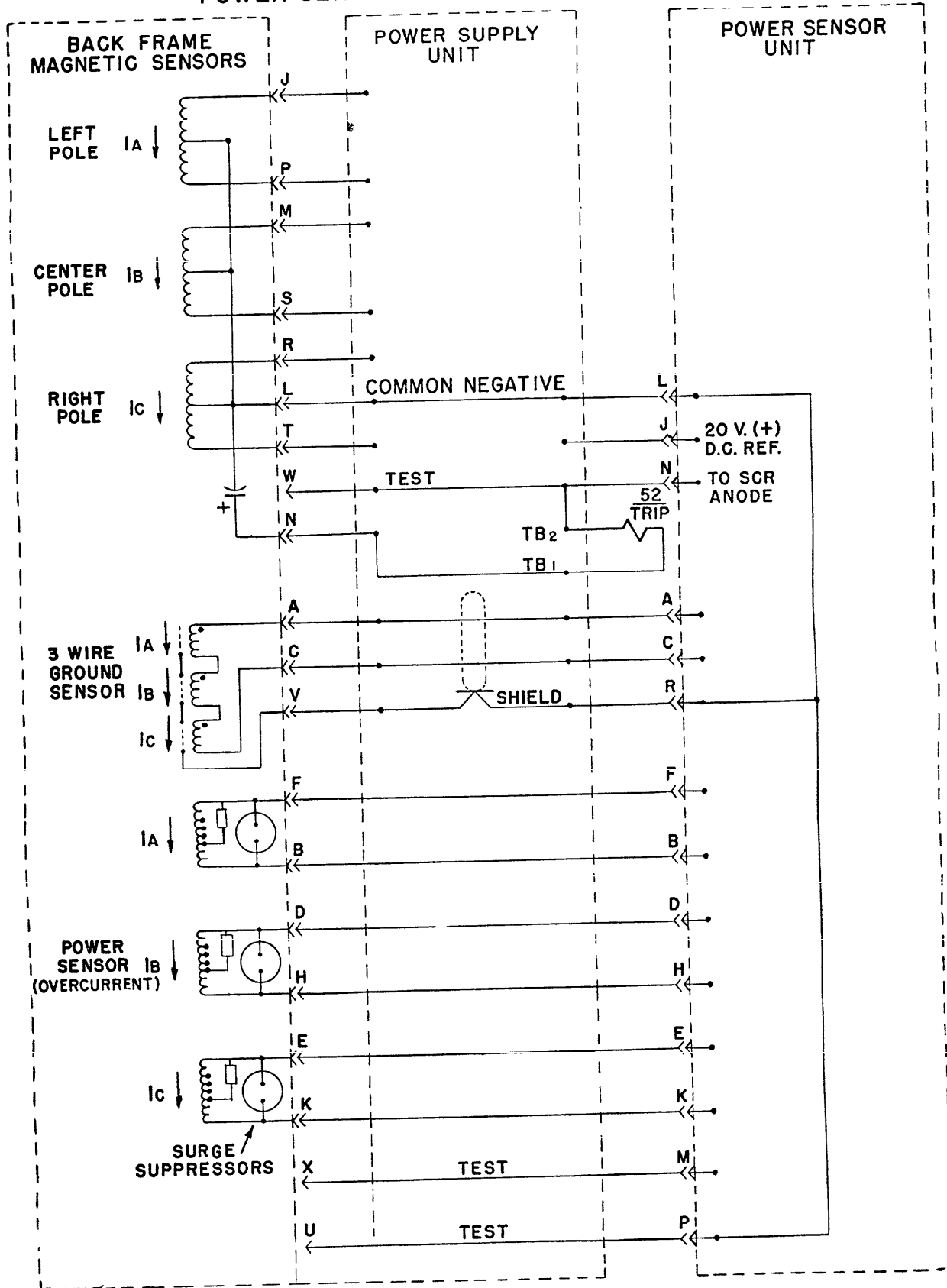

Figure 6. (133C9017-3) Power Sensor Cabling Diagram Drawing

AK-3-25

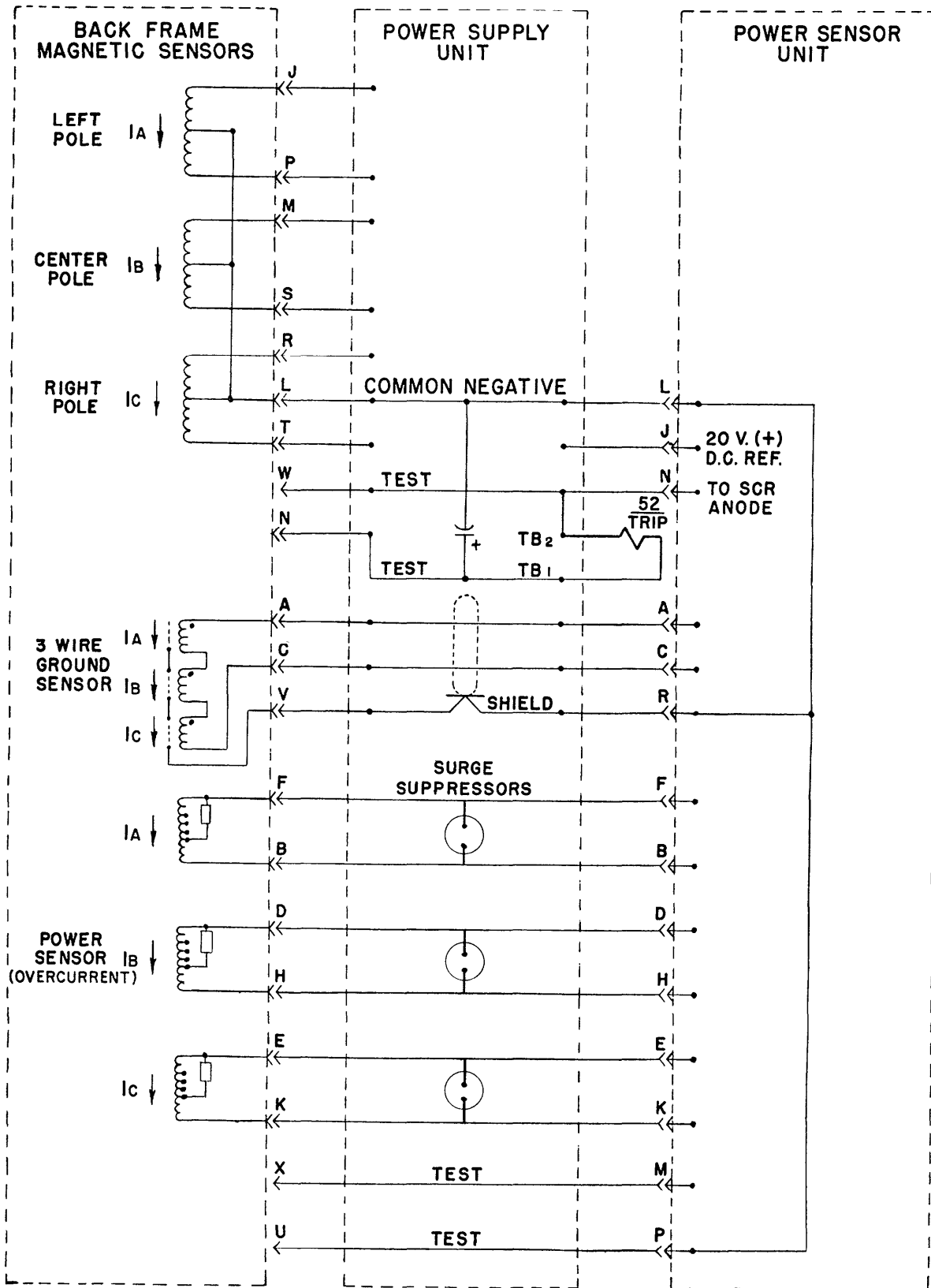

Figure 7. (133C9018-3) Power Sensor Cabling Diagram Drawing
AK-3-50/75/100

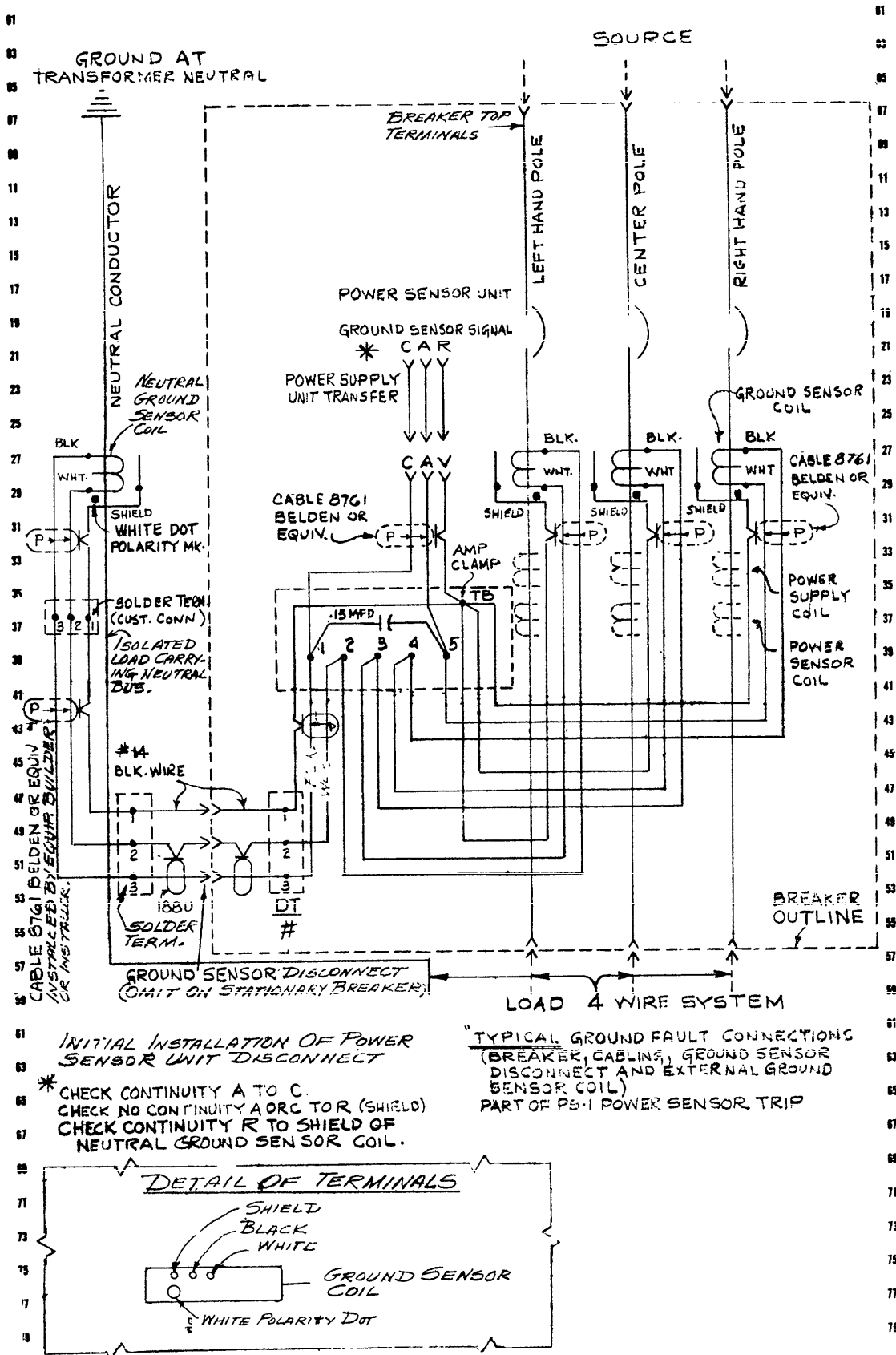

Figure 8. (138B2454-6) Ground Fault System Wiring Diagram