



Power Circuit Breakers

Type AKR

This manual when used in conjunction with Publication GEK-7310 (Maintenance Manual for AKR-3/3A-50 and AKRU-3A-50 breakers) provides maintenance instructions on the AKR breaker models and trip devices listed in Table 1.

TABLE 1

Frame Size (Amp)	Breaker Type & Mounting		Trip Device Type	
	Stationary	Drawout	ECS	SST
800	AKR-4-30, 30H	AKR-4A-30, 30H	X	
	AKR-5-30, 30H	AKR-5A-30, 30H		X
	--	AKRU-4A-30*	X	
	--	AKRU-5A-30*		X
1600	AKR-4-50, 50H	AKR-4A-50, 50H	X	
	AKR-5-50, 50H	AKR-5A-50, 50H		X
	--	AKRU-4A-50*	X	
	--	AKRU-5A-50*		X
2000	AKRT-4-50	AKRT-4A-50	X	
	AKRT-5-50	AKRT-5A-50		X

* - Integrally fused types

CONTENTS

Introduction	3
Constructional Differences.	3
Breaker Ratings	4
Drawout Breaker Interchangeability	5
Breaker Maintenance	6
Precautions.	6
Manual Handle Adjustment.	6
Contact Maintenance.	6
Contact Adjustment:	
AKR-30, -30H, AKRU-30	7
AKR-50, -50H, AKRU-50	8
AKRT-50	8
Contact Replacement:	
AKR-30, -30H, AKRU-30	10
AKR-50, -50H, AKRU-50, AKRT-50	10
Fused Breakers AKRU-30, -50	10
Fuse Sizes and Mounting	10
Special 2500A Fuse.	12
Open Fuse Lockout Device	12
Type SST Overcurrent Trip Device	14
Components.	14
Trip Characteristics	16
Troubleshooting	17
SST Test Set TAK-TS1.	18
False Tripping (Ground Fault)	19
Replacement of Current Sensors	19
Flux Shift Trip Device	20
Cabling Diagrams.	22
Ground Fault Defeat Cable	23
Type ECS Overcurrent Trip Device.	24
Components	24
Trip Characteristics	25
Cabling Diagram	26
ECS & SST Time-Current Curves	27

These instructions do not purport to cover all details or variations in equipment nor to provide for every possible contingency to be met in connection with installation, operation or maintenance. Should further information be desired or should particular problems arise which are not covered sufficiently for the purchaser's purposes, the matter should be referred to the General Electric Company.

MAINTENANCE MANUAL SUPPLEMENT

LOW-VOLTAGE POWER CIRCUIT BREAKERS

TYPES AKR/AKRU-30/50, AKRT-50 PER TABLE 1

INTRODUCTION

The data in this supplement pertains to the new 800A AKR-30 and the 2000A AKRT-50 frame breakers not covered by the existing AKR/AKRU-50 maintenance manual (publication GEK-7310). Information on the new ECS and SST solid-state trip devices also is included.

The new breaker models are derivatives of the 1600A frame AKR-50 design. Apart from the specific constructional differences identified below, the basic AKR-50 framework, mechanism and accessory devices are substantially common to all versions. Except for the 800A frame primary stud details, the external H x W x D dimensions are identical. Accordingly, a majority of the AKR-50 information now in publication GEK-7310 applies equally to the new types. Therefore, to avoid needless repetition, the scope of this supplement is confined principally to that descriptive and instructional material unique to the new models. Unless noted to the contrary, or otherwise discussed herein, the user should continue to employ GEK-7310 as the general, operational information source.

Complementing the above "new" material, this supplement includes additional information to expand and update existing GEK-7310 subject-matter where appropriate. Examples are revision of the operating handle adjustment procedure and reduction of the AKRU-50 minimum fuse size from 800A to 450A.

CONSTRUCTIONAL DIFFERENCES

The features which distinguish the new AKR/AKRT breakers from the parent AKR-50 frame size are listed below. For a detailed parts comparison, refer to "Renewal Parts Bulletin" GEF-4527.

AKR-30.

- a. An entirely new contact structure. Each pole employs three stationary mains, two stationary arcing and one movable contact arm. See Fig. 5.
- b. Primary studs carry four disconnect fingers per pole. See Fig. 1.
- c. Two additional opening springs, one at each end of the main shaft. See Fig. 4.

AKR-30H. Same as the AKR-30 except for modifications in the following areas:

- a. Arc quenchers.
- b. Closing springs.
- c. Extra insulation on shaft flyweights.
- d. Mounts one additional stationary main contact for a total of four; otherwise the contact structure is same as AKR-30. See Fig. 6.

NOTE: To visibly distinguish it from the AKR-30, the closing springs and arc quencher covers of the 30H are colored red.

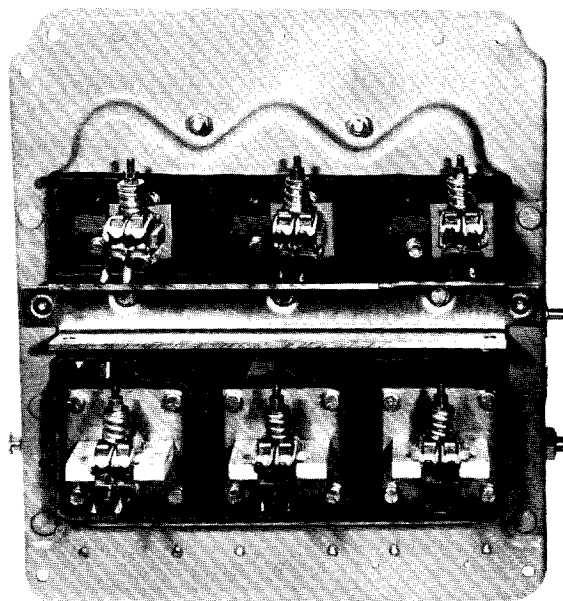

Fig. 1. Rear view of AKR-30 breaker

AKR-50H. An AKR-50 with extended short circuit ratings attained by special arc quenchers, closing springs and added insulation. Quencher tops and closing springs carry the same red color used on the AKR-30H.

AKRT-50. A 2000A extension of the 1600A frame AKR-50. Modifications are:

- a. New and larger upper stud assembly, movable contact arms and pivot block.
- b. Stationary main contacts increased from 6 to 8; otherwise the stationary contacts are identical to the AKR-50. See Figs. 8 and 9.

BREAKER RATINGS

AKR breakers are available in three frame sizes -- 800, 1600 and 2000 amperes. These values represent the maximum continuous current capability of the respective frames. However, each breaker carries a specific rating which is determined by the current sensor ampere rating (or tap setting) of the trip device with which it is equipped.

EXAMPLE: An AKR-5A-30 breaker with SST sensor tap set on 100A is rated 100A.

Short circuit ratings vary with the applied system voltage. On 240 V systems they are also dependent upon whether the overcurrent trip device contains an instantaneous trip element. See Table 2.

**TABLE 2
BREAKER RATINGS**

Frame Size (Amperes)	Breaker Type	Rated Maximum Voltage (60Hz ac)	3 ϕ Short Circuit Rating (kA RMS Sym)	
			With Instantaneous Trip	Without Instantaneous Trip
800	AKR-30	635	30	30
		508	30	30
254		42	30	
AKR-30H	635	42	42	
	508	42	42	
	254	50	42	
1600	AKR-50	635	42	42
		508	50	50
254		65	50	
AKR-50H	635	50	50	
	508	65	65	
	254	65	65	
2000	AKRT-50	635	42	42
		508	50	50
		254	65	50
800	AKRU-30	600	200	200
1600	AKRU-50	600	200	200

DRAWOUT BREAKER INTERCHANGEABILITY

In general, drawout breakers of the same type and rating are interchangeable in their equipment compartments; drawout breakers of different frame sizes are not interchangeable. To prevent inserting the wrong type breaker into a drawout compartment, suitable "rejection hardware" is affixed to each breaker and its compartment. Figure 4 shows a typical rejection bracket which aligns with a rejection pin in the drawout rail (Fig. 3). When the wrong type breaker is inserted into a compartment the bracket and pin do not mate, preventing the breaker from seating itself into the drawout rails.

There is one exception to the above. Breakers of the same frame size having different short circuit ratings may be interchanged in one direction only:

- a. An AKR-30H can be inserted into an AKR-30 compartment.
- b. An AKR-50H can be inserted into an AKR-50 compartment.

The rejection hardware prevents the converse of a. and b.

Figure 2 shows the rejection pin and bracket combinations employed. As determined by its intended breaker type, each drawout compartment has its rejection pin (or pins) installed in one of three positions (A, B or C front-to-rear) along the slide rail(s). Referring to Views 2 and 5, note that only the AKR-30H and 50H types employ two pins, one in each slide rail. The other breaker types use a single pin in the right side rail. AKRU-30 and 50 fused breakers use a single bracket, whereas all nonfused breakers carry two brackets. Use Fig. 2 as a guide for determining the proper breaker type(s) that will be accepted by any given compartment.

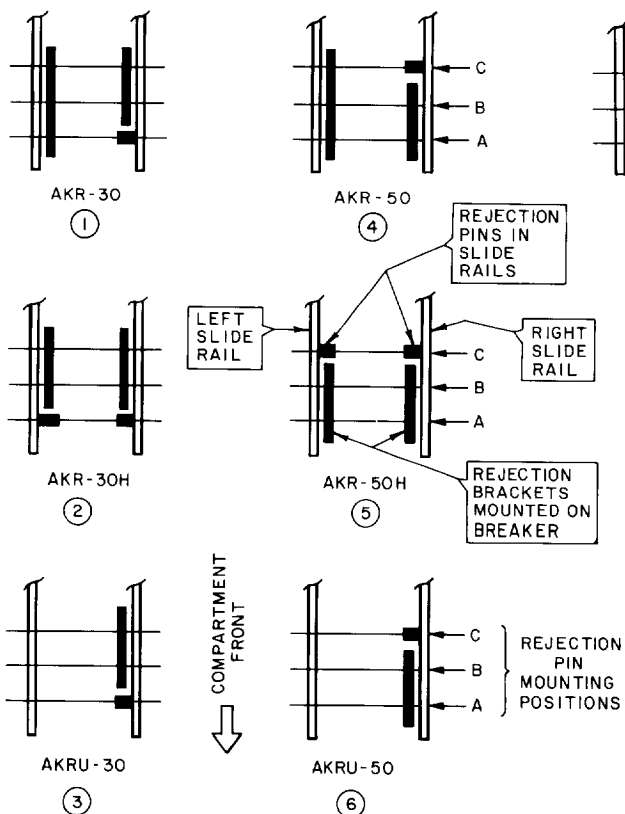

Fig. 2. Non-interchangeability (rejection) hardware arrangements in drawout compartments for breaker Types AKR-30/30H/50/50H, AKRT-50 and AKRU-30/50

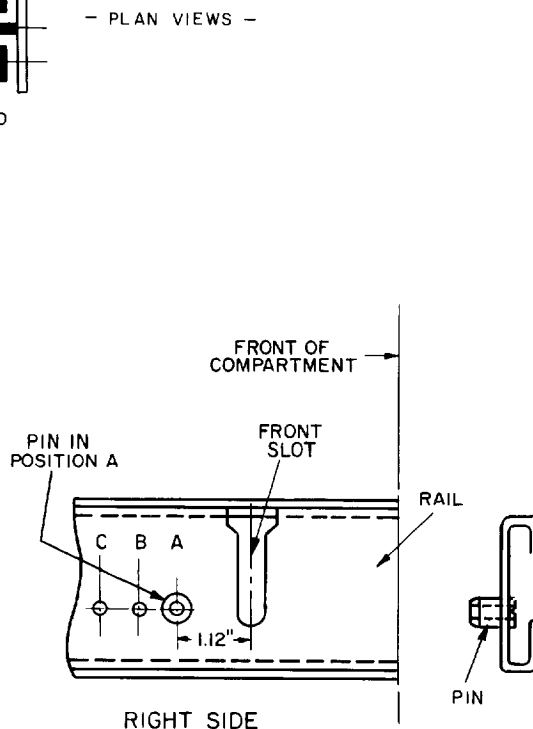

Fig. 3. Slide rail rejection pin locations

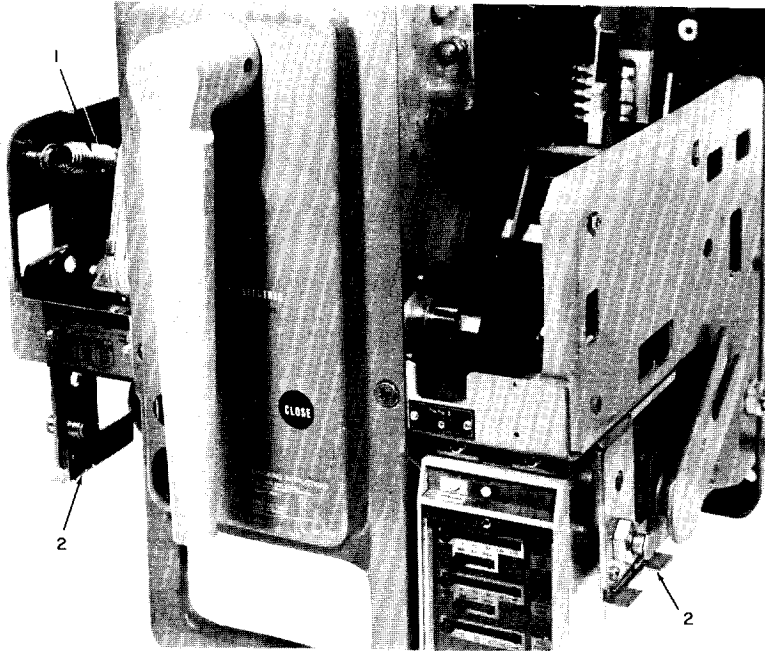

Fig. 4. AKR-5A-30 breaker

1. Opening spring
2. Rejection bracket

BREAKER MAINTENANCE

SAFETY PRECAUTIONS

BEFORE INSPECTING OR BEGINNING ANY MAINTENANCE WORK ON THE BREAKER, IT MUST BE DISCONNECTED FROM ALL VOLTAGE SOURCES, BOTH POWER AND CONTROL, AND BE IN THE "OPEN" POSITION.

MANUAL HANDLE ADJUSTMENT

On manually-operated AKR breakers, the closing springs may be charged either by a single 135 degree clockwise handle stroke or up to four multiple strokes of lesser swing. The following adjustment procedures should be performed using the single-stroke method. By so doing, proper multi-stroke operation is assured.

Referring to Fig. 13 of GEK-7310, the manual handle adjustment is made via adjustable link (16). The length of this link is controlled by turning a double-ended stud in its center. A hex section in mid-stud can be engaged by an open-end wrench. When looking down on the breaker, turning the wrench clockwise lengthens the link. The opposite motion shortens it. The range of adjustment is 300 degrees. In the confined space available, each wrench stroke imparts 15 degrees movement. The best setting is approximately mid-range.

If the link is too long, the handle stroke cannot extend the closing spring enough for it to go over center. In this event, use the maintenance handle to complete the spring charging. The breaker can then be closed and opened preparatory to further shortening of the link.

If the link is too short, one-stroke charging is not possible. However, more than one stroke will charge the springs.

CONTACT MAINTENANCE

Breakers subjected to frequent interruption of high currents may eventually require replacement of their contacts. The general rule for determining need of replacement is the loss of one-half or more of the mass of the contact tip material. Roughening or light pitting of the contact surface does not indicate loss of ability to carry or interrupt current.

When contacts are replaced, they must be adjusted to ensure that the proper amount of force is developed between the movable and stationary contacts when the breaker is closed. This is called the "wipe" adjustment. "Wipe" is the distance through which the stationary contacts move when the breaker closes. It is measured between the point of contact on a stationary contact when the breaker is open, and the position of the same point when the breaker is closed. The actual wiping motion is greater because the contacts over-travel. "Wiping" imparts a sliding or "scrubbing" action to the contacts.

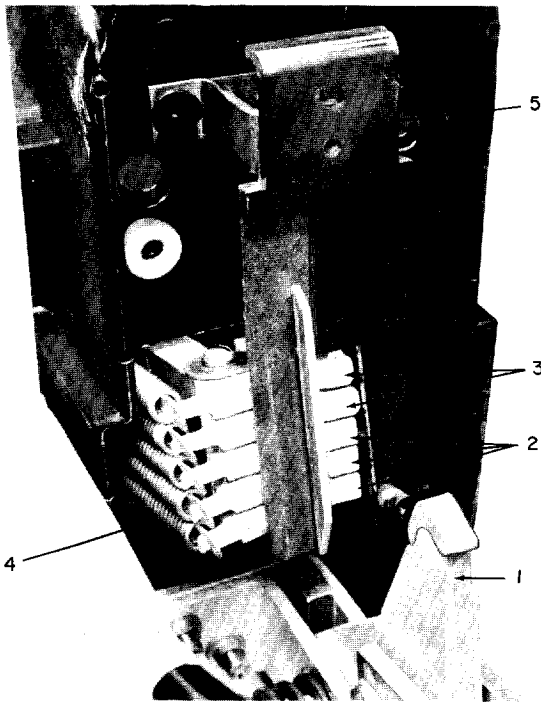

1. Movable contact arm
2. Stationary main contact
3. Stationary arcing contact
4. Contact spring
5. Arc runner

Fig. 5. AKR/AKRU-30 contact structure (arc quencher removed)

The wipe adjustment influences proper arc transfer during interruption of fault currents. "Transfer" of the arc is its forced sequential movement from the intermediate contacts to the arcing contacts to the arc runner and finally to the arc quencher where it is dissipated and extinguished. It is recommended that contact wipe be checked periodically during normal maintenance inspections.

CAUTION: BEFORE DOING ANY OF THE FOLLOWING CONTACT ADJUSTMENT AND REPLACEMENT WORK, MECHANICALLY DISCONNECT THE CLOSING SPRING FROM THE MECHANISM CAM SHAFT. THE BREAKER CAN NOW BE "SLOW-CLOSED" USING THE MAINTENANCE HANDLE.

CONTACT ADJUSTMENT Types AKR-30, 30H and AKRU-30

The contact arrangement of the 800 ampere frame AKR and AKRU-30 breakers differs significantly from that of the AKR-50 frame size. Each pole consists of a single movable contact arm acting against five stationary contacts, arranged vertically as shown in Fig. 5. Proceeding from top to bottom,

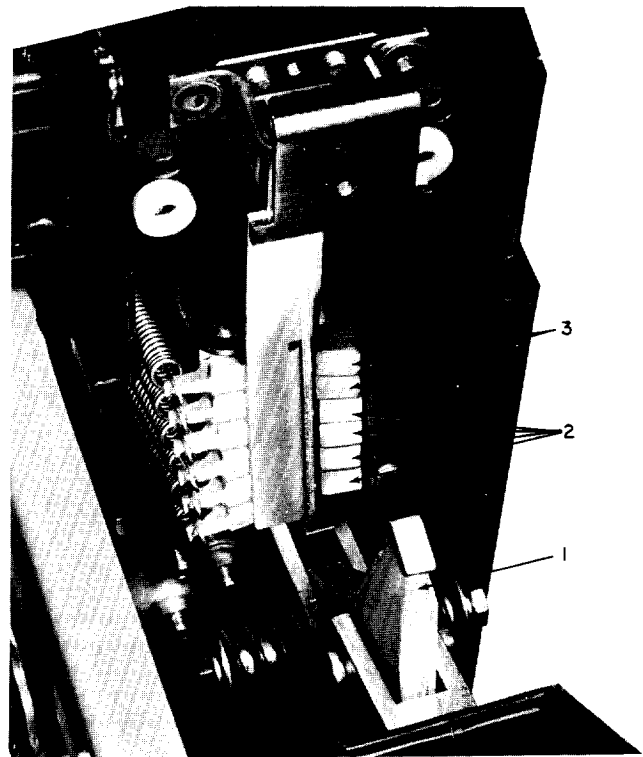

1. Movable contact arm
2. Stationary main contact
3. Stationary arcing contact

Fig. 6. AKR-30H contact structure

the first two contacts serve as the arcing contacts and the bottom three are the mains. There are no intermediate contacts.

The contact assembly for the AKR-30H breaker employs the same AKR/AKRU-30 configuration, but adds a fourth stationary main contact at the bottom. See Fig. 6.

The following wipe adjustment procedure is applicable to all AKR-30 types:

1. Open the breaker, remove arc quenchers.
2. Arrange the breaker for slow-closing as described on page 15 of GEK-7310.
3. Using the ratcheting maintenance handle, slow-close the breaker.
4. Select one pole and, using a flat or wire feeler gage, measure the gap between the top contact and its pivot stud as shown in Fig. 7. As necessary, adjust the gap to 0.060 ± 0.020 inch by turning the wipe adjustment stud.
5. Repeat this procedure on the other two poles.
6. Trip the breaker.

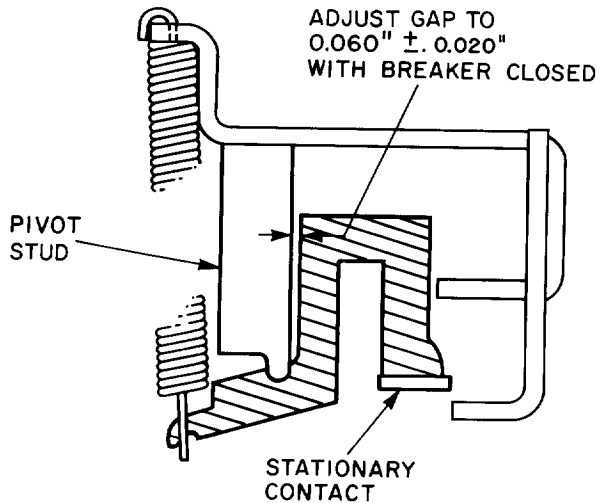

Fig. 7. AKR-30 wiper adjustment - view from top of breaker

CONTACT ADJUSTMENT Types AKR-50, 50H and AKRU-50

Use the following procedure to perform wiper adjustment:

1. Open the breaker, remove arc quenchers.
2. Arrange the breaker for slow-closing, as described on page 15 of GEK-7310.
3. Select one pole of the breaker and place a thin sheet or strip of tough insulating material, such as mylar, over the stationary arcing and intermediate contacts. This strip should be about two inches wide and must prevent the arcing and intermediate contacts from making contact when the breaker is closed.
4. Using the ratcheting maintenance handle, slow-close the breaker with the insulation held in place. Examine the insulation to make sure it "over-hangs" below the intermediate contacts.
5. Attach a continuity checker (bell-set or light) between the upper and lower stud.
6. Facing the breaker, turn the wiper adjustment stud clockwise until the checker indicates that the main contacts have parted. An open-end wrench fits the hex section on the stud.
7. Turn the stud counterclockwise until the main contacts just touch.
8. From this point, advance the stud counterclockwise 270 degrees. This will be 4-1/2 flats.
9. Trip the breaker, remove the insulating strips.
10. Repeat the above procedure on the other two poles.

CONTACT ADJUSTMENT Type AKRT-50

The contact structure of this 2000A breaker is conceptually identical to the 1600A AKR-50 except that it employs eight stationary main contacts instead of six. Constructionally, however, the upper stud assembly, movable contact arms and pivot block are unique to the AKRT-50. See Figs. 8 and 9.

The two movable contact arms are pin-coupled to a metal driving link whose opposite end is threaded and screws directly into the insulating link. This arrangement omits the wrench-operated wiper adjustment stud provided on the AKR-30 and -50 frames. Instead, wiper is adjusted by detaching the driving link from the movable contact arms and then rotating it with respect to the insulating link.

On the AKRT-50 the proper amount of contact wiper exists if, on a closed breaker, all of the stationary main contacts have moved away from their stops. This condition can be checked visually by removing the arc quenchers, closing the breaker and verifying that all eight stationary main contacts are "lifted off" their stops. Should wiper adjustment appear necessary, proceed as follows:

1. Open the breaker.
2. Arrange the breaker for slow-closing as described on page 15 of GEK-7310.
3. Selecting one pole, drift out the coupling pin and detach the driving link from the movable contact arms.
4. Screw the driving link completely into the insulating link.
5. Back out the driving link two and one-half turns. Exceed this by whatever amount is necessary to properly position the link within the movable contact arms.
6. Install the coupling pin and retainer rings.
7. Using the maintenance handle, slow-close the breaker and observe that all eight stationary main contacts move away from their stops. If this condition is not achieved, open the breaker, again remove the coupling pin and back out the driving link an additional half turn.
8. Reassemble, reclose the breaker and recheck wiper.
9. Repeat the above procedure on the other two poles.

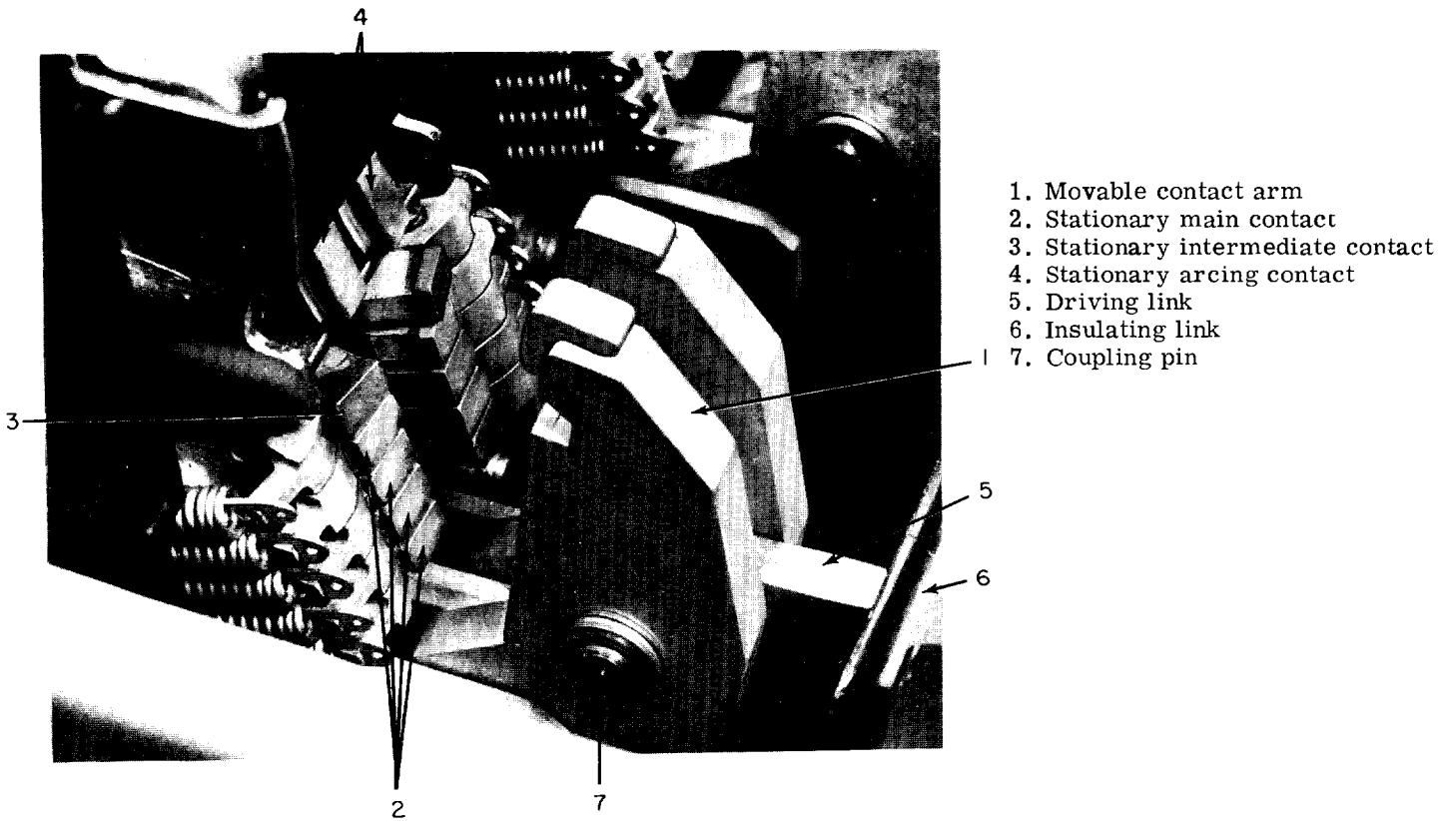

Fig. 8. AKRT-50 contact structure



Fig. 9. AKRT-50 Movable contact pivot block

CONTACT REPLACEMENT Types AKR-30, 30H and AKRU-30

The stationary contacts (arcing and mains) of the AKR-30 breaker frames are replaced in identical fashion to that employed for the intermediate and main stationary contacts of the AKR-50. To do so, however, it is necessary to first remove the arc runner by removing its three holding screws.

Replacement of the single movable contact arm is accomplished in like manner employed for the AKR-50 breakers, i.e., remove and replace the coupling pin, pivot pin, etc., as described below.

CONTACT REPLACEMENT Types AKR-50, 50H, AKRU-50 and AKRT-50

Referring to Fig. 17 of GEK-7310, arcing contacts (1) are released by removing the arc runner (5) and the arcing contact pivot (6). When reassembling, make sure that the insulating spacers on the ends of the arcing contact pin (7) and the insulating washers (8) under the lower arc runner fastening screws are replaced.

Intermediate (2) and main contacts (3) are removed by disconnecting their springs. The end pieces on the springs (9) have a small hole for inserting a spring puller. While holding the contact, pull the spring and lift it off the end of the contact. Replace the contact by holding it in position (inner end behind the contact stop) while extending and engaging the spring on the outer end. A suitable

puller can be fashioned by forming a hook on the end of a length of 1/16-inch diameter steel wire.

The two movable contact arms (4) are removed by drifting out pin (10) connecting them to the insulated coupling (11). Right angle tru-arc pliers are needed to remove and replace the tru-arc retainer on the end of the pin.

Next, remove the fastening screws, washers, springs and pivot pin from the pivot below. When replacing the arms ensure that all spacers, springs and washers are returned to their original position. Tighten the two bolts in the contact arm pivot.

AKRU-30 and -50 FUSED BREAKERS

Except for the open fuse lockout device and the integrally-mounted fuses on the upper studs, the AKRU-30 and -50 breakers are identical to the unfused AKR-30 and -50 models. Overcurrent trip devices are the same for both types.

Fuse Sizes and Mounting

Table 3 lists the range of fuse sizes available for these breakers. The Class L fuses are mounted as shown in Fig. 10. Other than the 800A size, which has a single mounting hole per tang, each L fuse tang has two holes sized for one-half inch bolts.

Class J fuses rated 300 thru 600A have one mounting hole per tang. The 300, 350 and 400A sizes require copper adapter bars per Fig. 11.

**TABLE 3
GE CLF FUSES FOR AKRU BREAKERS**

NEMA Fuse Class 600V 60 Hz	Breaker Type AKRU-		Ampere Rating	Cat. No.	Melting Time-current Curves
	30	50			
J		--	300*	GF8B300	GES-8004
		--	350*	350	
		--	400*	400	
		--	450	450	
		--	500	500	
		--	600	600	
L		--	800	800	GES-8005
		--	1000	1000	
		--	1200	1200	
		--	1600	1600	
		--	2000	2000	
Special	--	2500	GF9F2500AK	183B7832	

*Mounting adapter required - see Fig. 11

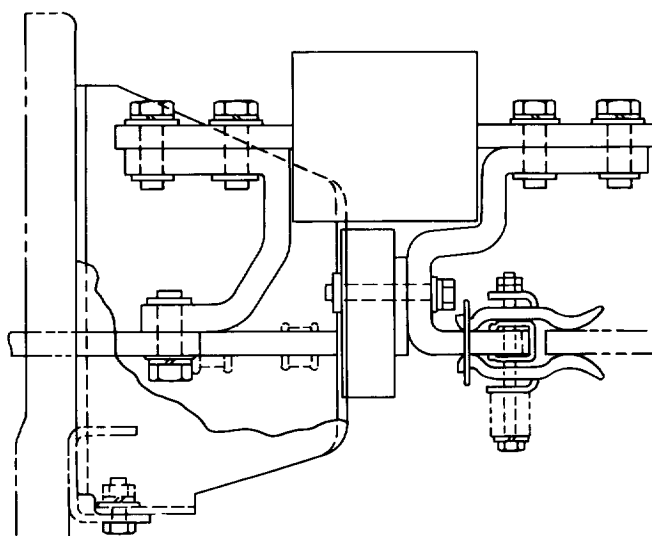

Fig. 10. Typical mounting for class "L" fuse on AKRU-30 and -50 breakers

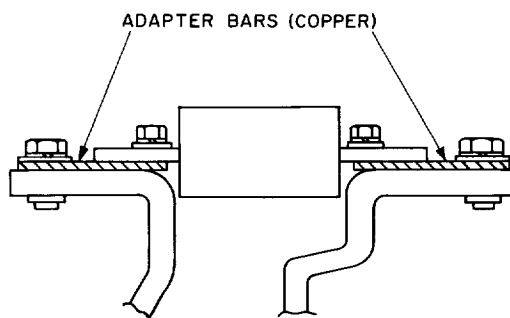
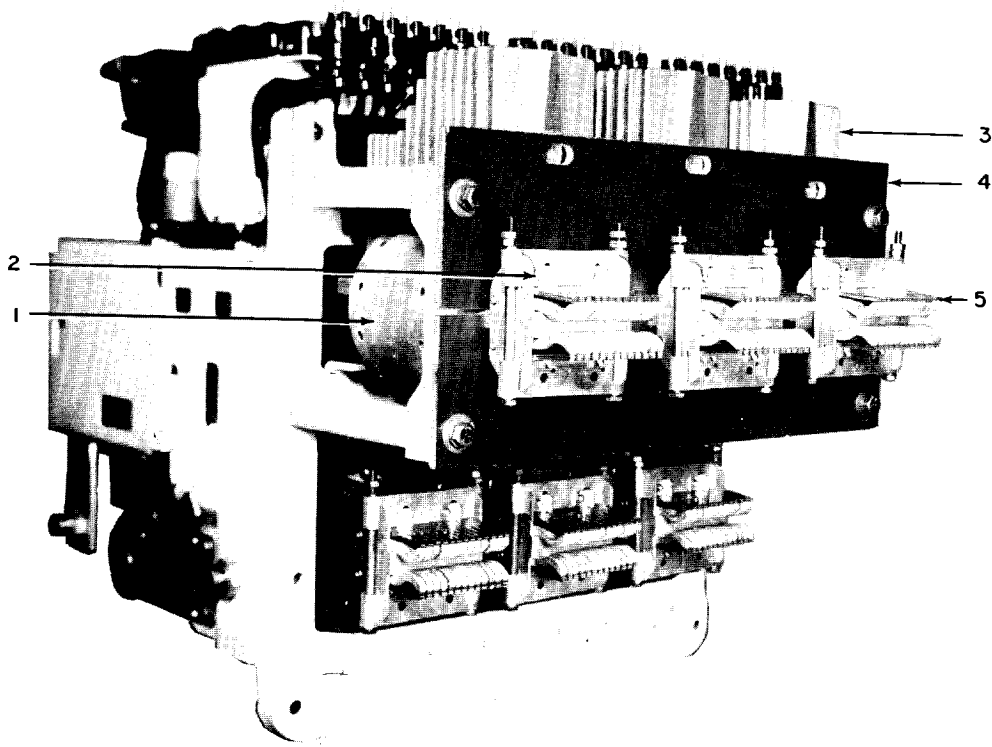

Fig. 11. Mounting for 300, 350 and 400A Class J fuses on AKRU-30 breakers



1. Special 2500A Fuse
2. Disconnect Key
3. Heat Sink
4. Upper Barrier
5. Primary Disconnect

Fig. 12. AKRU-50 breaker with special 2500A fuse

Special 2500A Fuse for AKRU-50

This fuse provides a melting time-current characteristic that coordinates with 1600A trip devices. Compared physically with a 2500A NEMA Class L fuse, the special fuse is more compact (shorter); its tangs are specially configured and offset to achieve the required pole-to-pole fuse spacing; a special primary disconnect assembly mounts directly on the outboard tang of the fuse. Considering their unique mounting provisions, when replacing these fuses the following procedure should be adhered to (Refer to Fig. 12):

1. Remove the primary disconnect assembly from the fuse tang, accomplished by first loosening the two keys (2) via their holding screw and pulling them upward and out. After the keys are removed, pull the disconnect assembly off the end of the fuse tang.

NOTE: This removal does not disturb the disconnect's clamping force adjustment.

2. Remove the upper barrier (4).

3. Detach the inboard end of the fuse by removing the two 1/2 inch - 13 bolts. A ratchet and socket with a short extension will be required.

4. Remove the heat sink (3).

5. Remove the fuse.

6. Install the new fuse by reversing the disassembly procedure. Ensure that the mating faces of the fuse and heat sink are clean.

CAUTION: WHEN REPLACING THE FUSE IN THE LEFT POLE (FRONT VIEW) OF THE BREAKER, NOTE PARTICULARLY THAT THIS FUSE IS MOUNTED DIFFERENTLY THAN THE OTHER TWO FUSES. AS SHOWN IN FIG. 14, FOR THIS PHASE THE FUSE IS ROTATED 180 DEGREES ABOUT ITS AXIS SO THAT ITS INBOARD TANG IS POSITIONED BENEATH THE BREAKER STUD. THIS TANG IS OFFSET WITH RESPECT TO THE OPPOSITE END (SEE FIG. 13), SO THAT ROTATING THE FUSE DOES NOT ALTER THE POSITION OF THE PRIMARY DISCONNECT.

Open Fuse Lockout Device

Refer to GEK-7310, page 31.

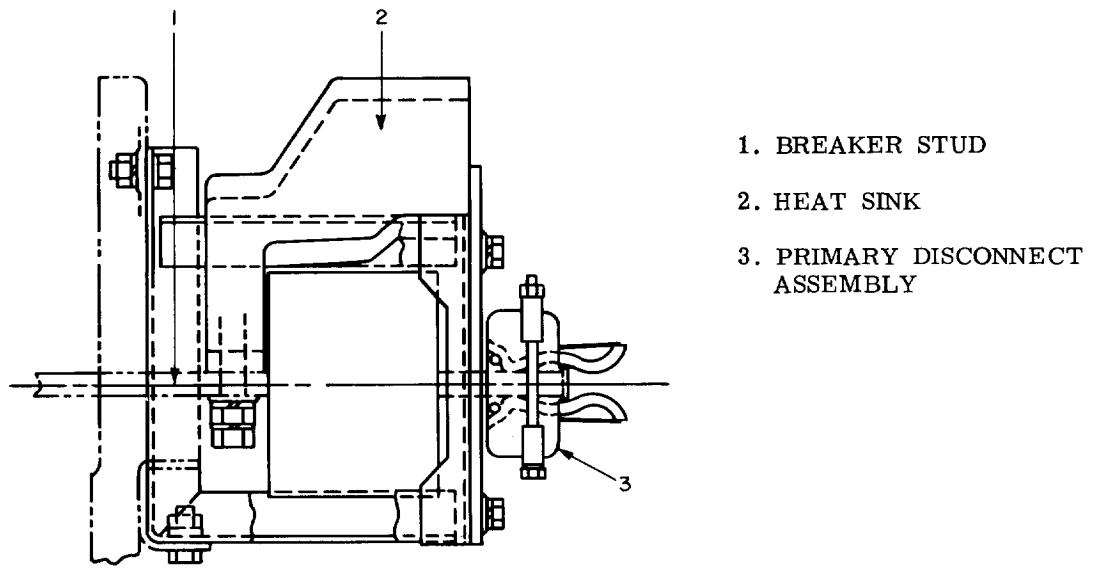

Fig. 13. Mounting for special 2500A fuse on AKRU-50 breaker

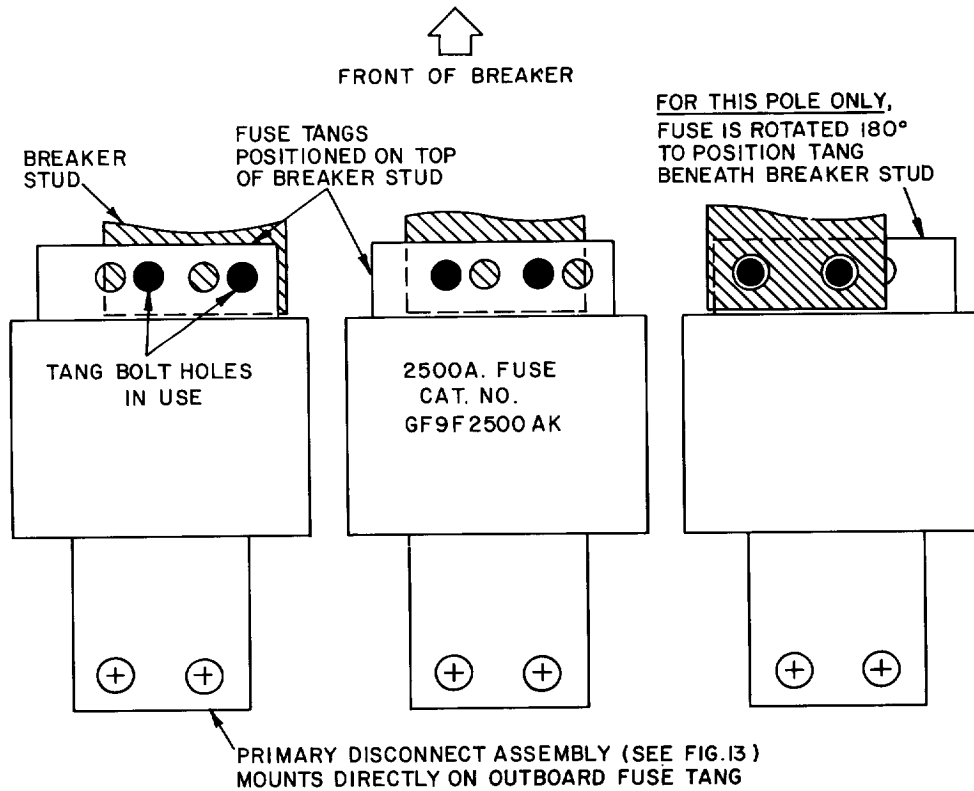

Fig. 14. Plan view of AKRU-50 breaker showing 2500A fuse tang positions

TYPE SST OVERCURRENT TRIP DEVICE

The SST is a solid-state, direct-acting, self-powered trip device system. Referring to the block diagram of Fig. 16 and the photograph of Fig. 15, it comprises the following individual components:

Programmer Unit - provides the comparison basis for overcurrent detection and delivers the energy necessary to trip the breaker. Contains the electronic circuitry for the various trip elements. Their associated pickup and time delay adjustments (set-points) are located on the face plate. Depending on the application, programmer units may be equipped with various combinations of Long Time, Short Time, Instantaneous and Ground Fault trip elements. See Table 4 for available ratings, settings and trip characteristics.

The SST programmer units can be optionally equipped with trip indicators (targets). These are pop-out, mechanically-resettable plungers located across the top of the programmer's front. Units with a ground fault element employ three targets: from left to right, the first is for overload, the second for short circuit (actuated by the short time and instantaneous elements) and the third for ground fault. The latter is omitted on units without ground fault.

Each target pops out when its associated trip element operates to trip the breaker. After a trip, the popped target must be reset by hand. However, neglecting to reset does not affect normal operation of any trip element or prevent the breaker from being reclosed.

Current Sensors - each pole mounts a single sensor coil (CT) which supplies the power and signal inputs necessary to operate the trip system. Each sensor has four taps which provide field adjustment of the trip device's continuous ampere rating. See Fig. 18.

The SST Ground Fault trip element operates on the principle that the instantaneous values of current in the three conductors (four on 4-wire systems) add to zero unless ground current exists. On SST's equipped with Ground Fault, the ground trip signal is developed by connecting each phase sensor in series with a companion primary winding on a ground differential transformer mounted in the programmer unit. Its secondary output is zero so long as there is no ground current.

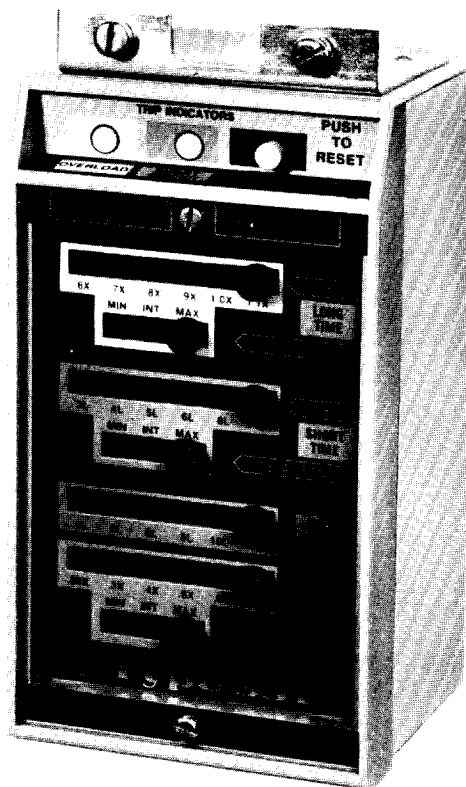

Fig. 15. SST Programmer unit

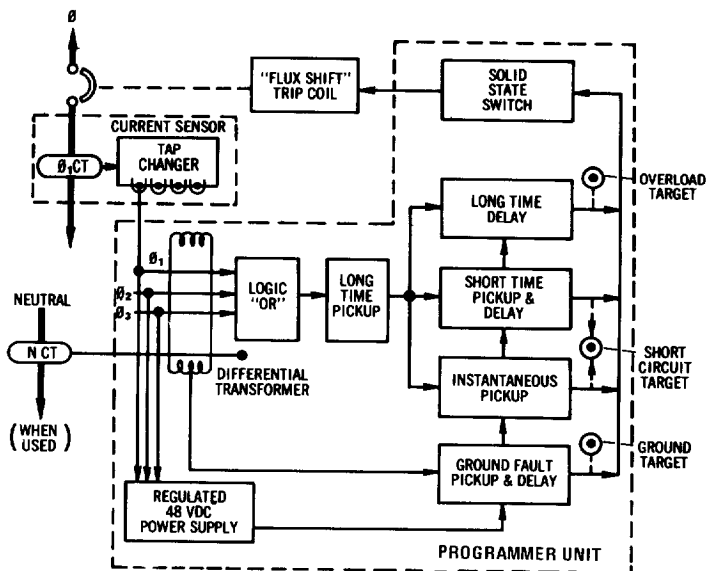
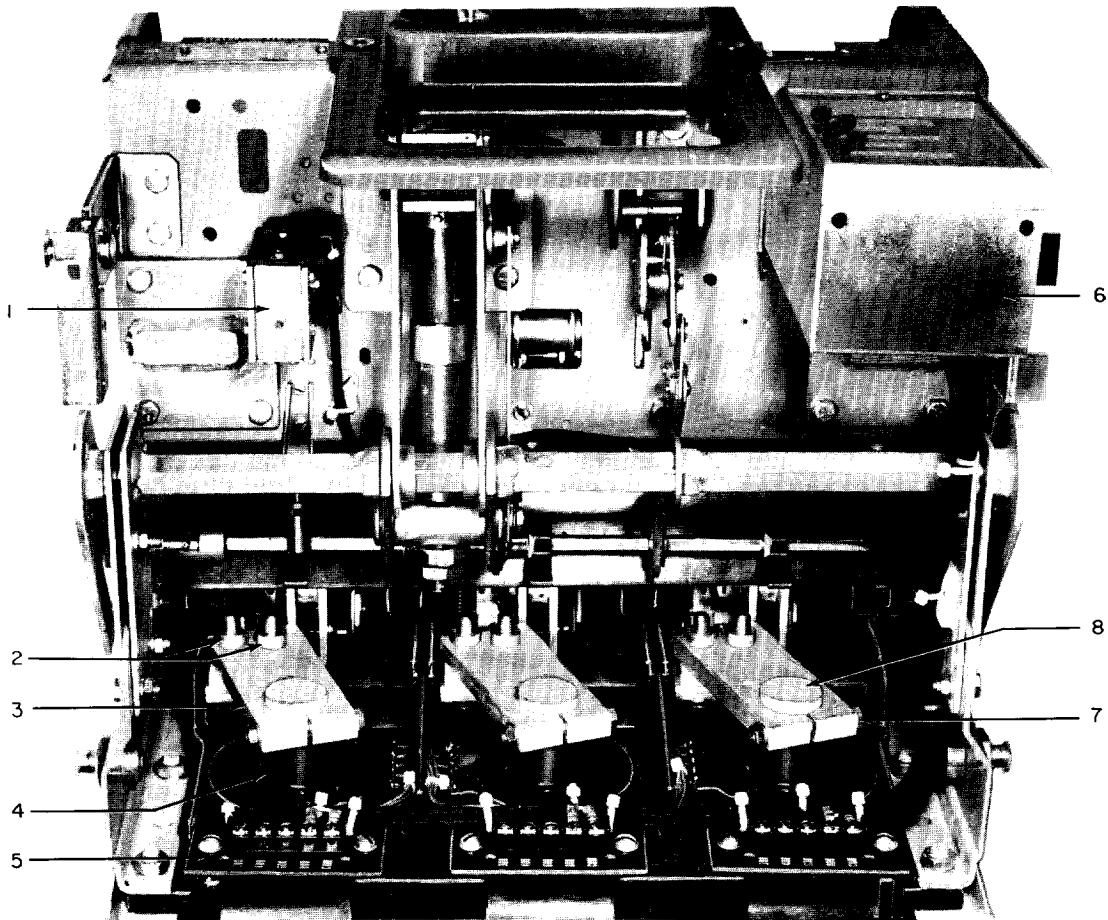

Fig. 16. SST Block diagram



- | | |
|---------------------------|-----------------------|
| 1. Flux shift Trip Device | 5. Tap Terminal Board |
| 2. Allen-head Screws | 6. Programmer Unit |
| 3. Stud Connector | 7. Clamp Bolt |
| 4. Current Sensor | 8. Sensor Stud |

Fig. 17. AKR-5A-30 breaker with SST trip device

Application of the Ground Fault element on 4-wire systems with neutral grounded at the transformer requires an additional, separately mounted sensor (Fig. 19) inserted in the neutral conductor; its secondary is connected to a fourth primary winding on the ground differential transformer. See Fig. 27. This "fourth-wire" neutral sensor is an electrical duplicate of the phase sensor, including taps. Therefore, when taps are changed on the phase sensors, those on the neutral sensor must be correspondingly positioned.

Flux Shift Trip Device - a low-energy, electromagnetic device which, upon receipt of a trip signal from the programmer unit, trips the breaker by actuating the trip shaft. See Fig. 22.

All components except the neutral sensor are mounted on the circuit breaker. The phase sensors are located on the breaker's back frame. The programmer unit and the flux shift trip device are mounted on the breaker's front frame. These components are interconnected by wiring harness and disconnect plugs, as shown on the cabling diagrams (Figs. 25 and 26).

When used, the neutral sensor is separately mounted in the bus or cable compartment of the switchgear. In drawout construction, its output is automatically connected to the breaker via secondary disconnect blocks. See Fig. 20.

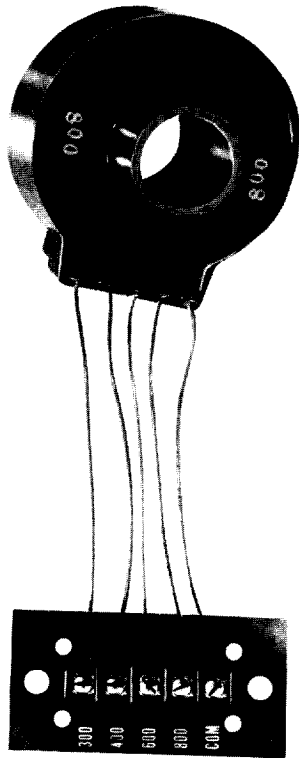
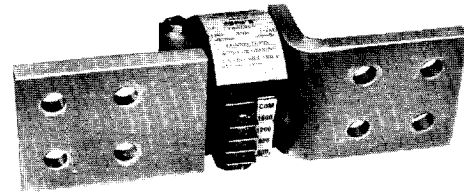
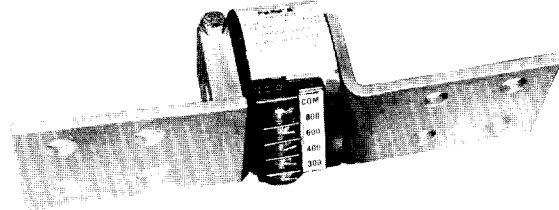

Fig. 18. SST phase sensor with tap board



600 - 1600 A



300 - 800 A

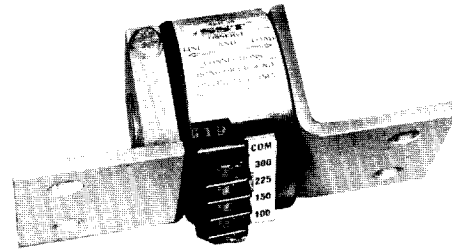

100 - 300 A

Fig. 19. SST Neutral sensors

TABLE 4
SST TRIP CHARACTERISTICS

Breaker Type	Frame Size (Amperes)	X = Trip Rating in Amperes = Sensor Tap (Sensor Ampere Taps)	SST PROGRAMMER ADJUSTMENT RANGE (Set Points)								
			Long Time		Short Time		Instantaneous Pickup (Multiple of L)	GROUND FAULT			
			Pickup (1) (Multiple of X)	Time Delay Band (3) (Seconds)	Pickup (2) (Multiple of L)	Time Delay Band (4) (Seconds)		Pickup (2) (Multiple of X)	Time Delay Band (4) (Seconds)		
AKR-30	800	100, 150, 225, 300 - or - 300, 400, 600, 800	.6, .7, .8, .9, 1.0, 1.1 (X)	Maximum 22	3, 4, 5, 6, 8, 10 (L)	Maximum 0.35	4, 5, 6, 8, 10, 12 (L)	.4, .5, .6, .8, 1.0, 1.2 (X)	Maximum 0.30		
AKR-50	1600	300, 400, 600, 800 - or - 600, 800, 1200, 1600		Intermed. 10				Intermed. 0.21		.25, .3, .4, .5, .6, .7 (X)	Intermed. 0.165
AKRT-50	2000	800, 1200, 1600, 2000		Minimum 4				Minimum 0.095		.2, .25, .3, .4, .5, .6 (X)	Minimum 0.065

① Pickup tolerance is ± 9%

② Pickup tolerance is ± 10%

③ Time delay shown at 600% of long time pickup setting (6L), at lower limit of band.

④ Time delay shown at lower limit of band.

(See pages 28, 29 and 30 for applicable time-current curves)

TROUBLESHOOTING

When malfunctioning is suspected, the first step in troubleshooting is to examine the circuit breaker and its power system for abnormal conditions such as:

- a) Breaker tripping in proper response to over-currents or incipient ground faults.
- b) Breaker remaining in a trip-free state due to mechanical interference along its trip shaft.
- c) Inadvertent shunt trip activations.

WARNING: DO NOT CHANGE TAPS ON THE CURRENT SENSORS OR ADJUST THE PROGRAMMER UNIT SET KNOBS WHILE THE BREAKER IS CARRYING CURRENT.

Once it has been established that the circuit breaker can be opened and closed normally from the test position, attention can be directed to the trip device proper. Testing is performed by either of two methods:

1. Conduct high-current, single-phase tests on the breaker using a high current-low voltage test set.

NOTE: For these single-phase tests, special connections must be employed for SST breakers equipped with Ground Fault. Any single-phase input to the ground differential transformer will generate an unwanted "ground fault" output signal which will trip the breaker. This can be nullified either by

- (a) testing two poles of the breaker in series, or
- (b) Using the Ground Fault Defeat Cable as shown in Fig. 28. This special test cable energizes all the primary windings of the differential transformer in a self-cancelling, series-parallel connection so that its secondary output is always zero.

2. Test the components of the SST system using portable Test Set Type TAK-TSI (Fig. 21). The applicable test procedures are detailed in Instruction Book GEK-64454 and are summarized on the next page.

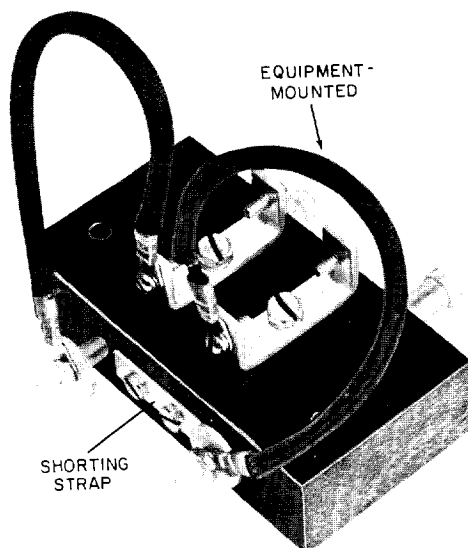
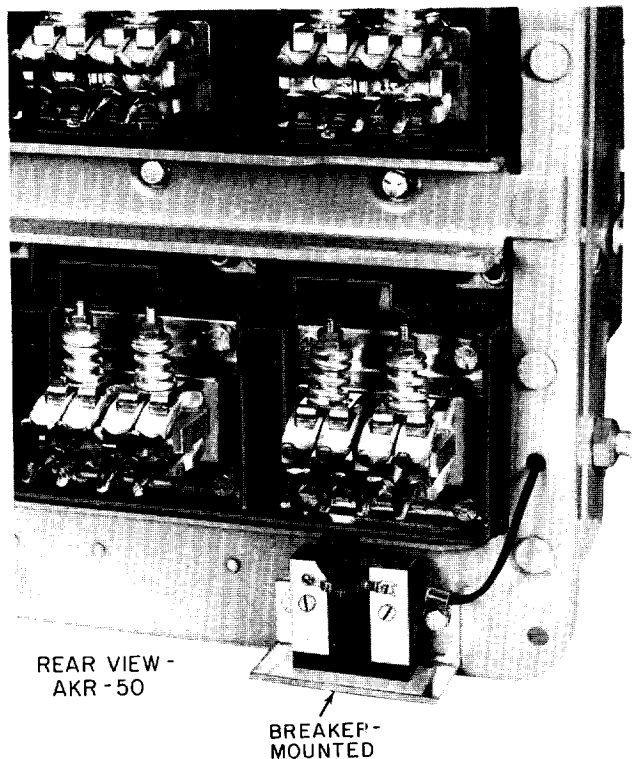

Fig. 20. Neutral sensor secondary disconnect blocks



Fig. 21. SST/ECS test set, cat. no. TAK-TS1

USING THE SST TEST SET

The TAK-TS1 Test Set is a portable instrument designed for field-checking the time-current characteristics and pickup calibration of the SST's various trip elements. It can verify the ability of the Flux-Shift Trip Device to trip the breaker and, in addition, includes means for continuity checking the phase sensors.

WARNING: BEFORE CONNECTING THE TEST SET TO THE BREAKER TRIP DEVICE SYSTEM, ENSURE THAT THE CIRCUIT BREAKER IS COMPLETELY DISCONNECTED FROM ITS POWER SOURCE. ON DRAWOUT EQUIPMENT, RACK THE BREAKER TO ITS DISCONNECTED POSITION. VERIFY THAT THE BREAKER IS TRIPPED.

Either of two test modes may be employed:

"A" - Programmer Unit Only. These tests are conducted with the programmer unit disconnected from the breaker. During test, the unit can remain attached to the breaker or may be completely removed from it.

CAUTION: NEVER DISENGAGE THE HARNESS CONNECTOR FROM THE PROGRAMMER UNIT ON A BREAKER THAT IS ENERGIZED AND CARRYING LOAD CURRENT. THIS WILL OPEN-CIRCUIT THE CURRENT SENSORS, ALLOWING DANGEROUS AND DAMAGING VOLTAGES TO DEVELOP.

Test scope:

1. Verify the time-current characteristics and pickup calibration of the various trip elements.
2. Verify operation of the SST target indicators on programmer units so equipped.

"B" - Complete Trip Device System. For these tests, the programmer unit must be mounted on the breaker and connected to its wiring harness.

Test scope:

1. All "A" tests previously described, plus provision for optionally switching the programmer's output to activate the Flux-Shift Trip Device and verify its operation by physically tripping the breaker.
2. Check phase sensor continuity.

In the event that any component of the SST system does not perform within the limits prescribed in test instructions GEK-64454, it should be replaced.

FALSE TRIPPING - BREAKERS EQUIPPED WITH GROUND FAULT

When nuisance tripping occurs on breakers equipped with the Ground Fault trip element, a probable cause is the existence of a false "ground" signal. As indicated by the cabling diagram of Fig. 26, each phase sensor is connected in series with a primary winding on the Ground Fault differential transformer. Under no-fault conditions on 3-wire load circuits, the currents in these three windings add to zero and no ground signal is developed. This current sum will be zero only if all three sensors have the same electrical characteristics. If one sensor differs from the others (i.e., different rating or wrong tap setting), the differential transformer can produce output sufficient to trip the breaker. Similarly, discontinuity between any sensor and the programmer unit can cause a false trip signal.

If nuisance tripping is encountered on any breaker whose SST components have previously demonstrated satisfactory performance via the TAK-TS1 Test Set, the sensors and their connections should be closely scrutinized. After disconnecting the breaker from all power sources,

- a) Check that all phase sensors are the same type (ampere range).
- b) Ensure that the tap settings on all 3-phase sensors are identical.
- c) Verify that the harness connections to the sensors meet the polarity constraints indicated by the cabling diagram, i.e., white wire to COMMON, black wire to TAP.
- d) On Ground Fault breakers serving 4-wire loads, check that the neutral sensor is properly connected (see cabling diagram Fig. 27). In particular,
 - (1) Verify that the neutral sensor has the same rating and tap setting as the phase sensors.
 - (2) Check continuity between the neutral sensor and its equipment-mounted se-

condary disconnect block. Also check for continuity from the breaker-mounted neutral secondary disconnect block through to the female harness connector (terminals L and N).

- (3) If the breaker's lower studs connect to the supply source, then the neutral sensor must have its LOAD end connected to the source.
- (4) Ensure that the neutral conductor is carrying only that neutral current associated with the breaker's load current (neutral not shared with other loads).
- e) If the preceding steps fail to identify the problem, then the sensor resistances should be measured. Since the phase and neutral sensors are electrically identical, their tap-to-tap resistances should closely agree.

REPLACEMENT OF CURRENT SENSORS

Referring to Fig. 17, removal of individual SST current sensors is accomplished as follows:

- a) Disconnect the breaker harness from the tap terminal board (5), removing cable ties as necessary. Unfasten the terminal board from the breaker base.
- b) At the rear of the breaker, remove the two Allen head screws (2) to separate the stud connector (3) from the contact pivot block.
- c) Loosen the clamping bolt (7) and remove the stud connector. Lift out the sensor and its tap terminal board.

NOTE: *To provide more working clearance to adjacent accessories, it may sometimes be necessary to remove the sensor stud (8) also. Do this by removing its four holding bolts, accessible from the rear of the breaker (see Fig. 20).*

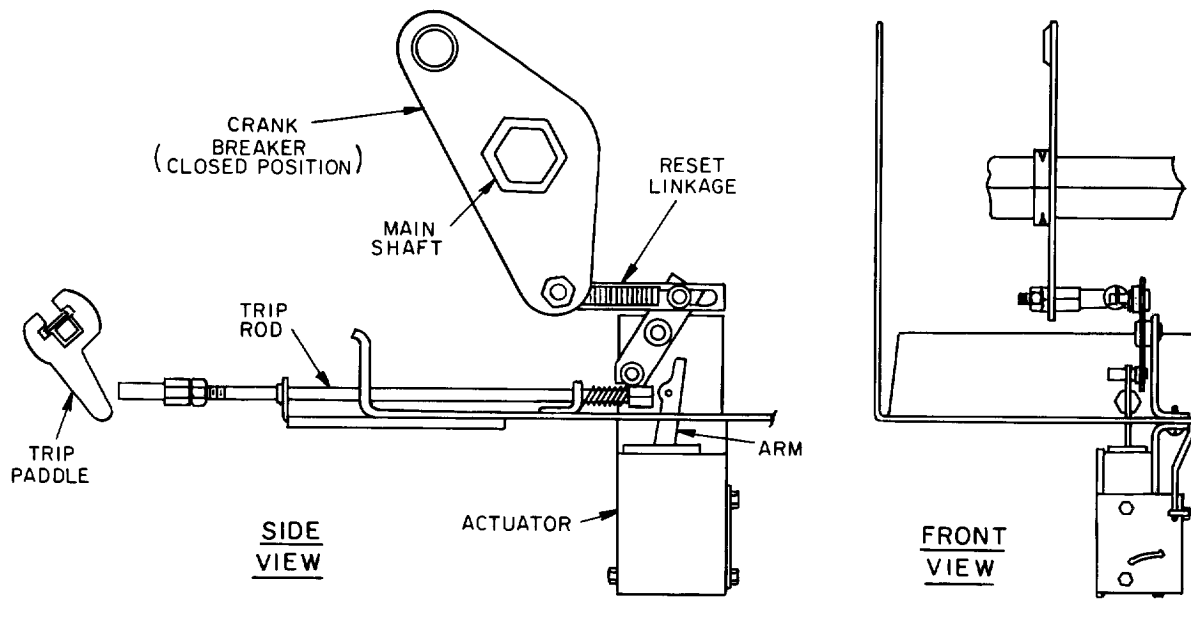

Fig. 22. Flux shift trip device and operating linkages

FLUX SHIFT TRIP DEVICE

The mounting arrangement of this component is illustrated in Figs. 22 and 23. An electromagnetic actuator located on the underside of the front frame is coupled to the breaker's trip shaft via a trip rod driven by the actuator arm. The actuator is a solenoid whose armature is spring-loaded and held in its normal (Reset) position by a permanent magnet. In this state the spring is compressed.

So long as the actuator remains in the Reset position, the breaker can be closed and opened normally at will. However, when a closed breaker receives a trip signal from the programmer unit, the actuator is energized and its solenoid flux opposes the magnet, allowing the spring to release the armature; this drives the trip rod against the trip shaft paddle, tripping the breaker.

As the breaker opens, the actuator arm is returned to its normal (Reset) position via linkage driven by a crank on the breaker's main shaft. The permanent magnet again holds the armature captive in readiness for the next trip signal.

The trip device requires only one adjustment - the trip rod length. As shown in Fig. 24, the clearance between the trip rod end and the trip shaft paddle is gaged by a 0.125 inch diameter rod. Ad-

just gap to 0.125 inch + 0.015 inch. To adjust, open the breaker and restore the breaker mechanism to its Reset position. Loosen the jam nut, rotate the adjuster end until the proper gap is attained, then retighten the jam nut.

The actuator is a sealed, factory-set device and requires no maintenance or field adjustment. In case of malfunction, the complete actuator unit should be replaced. When making the electrical connection to the replacement unit, it is recommended that the breaker harness be cut at some convenient point and the new actuator leads solder-spliced thereto. An alternate method is to untie the breaker harness and remove the old actuator leads directly from the female AMP connector on the end of the breaker harness. However, AMP extraction tool Cat. No. 305183 is required for this method.

CAUTION: IN THE EVENT THAT THE SST TRIP DEVICE MUST BE RENDERED INOPERATIVE TO ALLOW THE BREAKER TO CARRY CURRENT WITHOUT BENEFIT OF OVERCURRENT PROTECTION, THE RECOMMENDED METHOD IS TO SHORTEN THE TRIP ROD BY TURNING ITS ADJUSTER END FULLY CLOCKWISE. THIS PREVENTS ACTUATION OF THE TRIP SHAFT PADDLE.

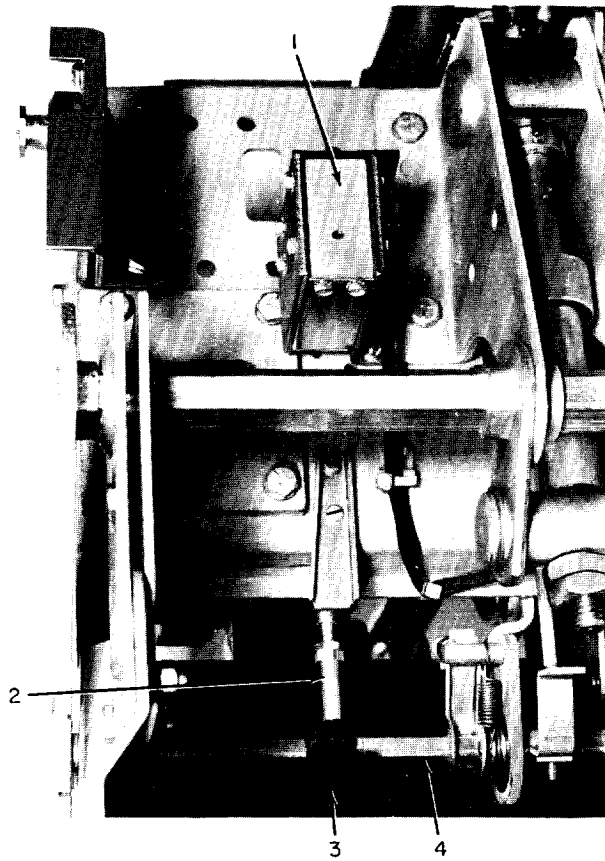

Bottom view

- 1. Actuator
- 2. Trip rod adjuster end
- 3. Trip paddle

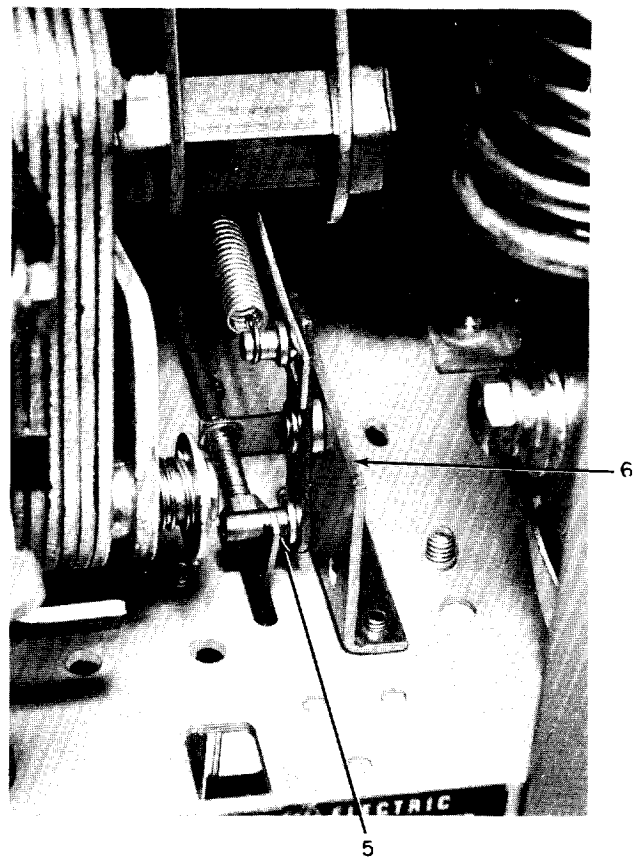

Top view

- 4. Trip shaft
- 5. Actuator arm
- 6. Reset linkage

Fig. 23. Flux shift trip device components

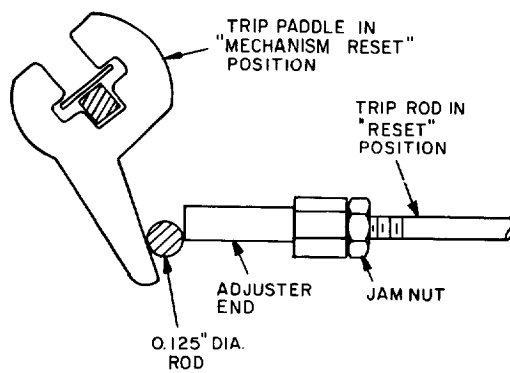

Fig. 24. Trip rod adjustment

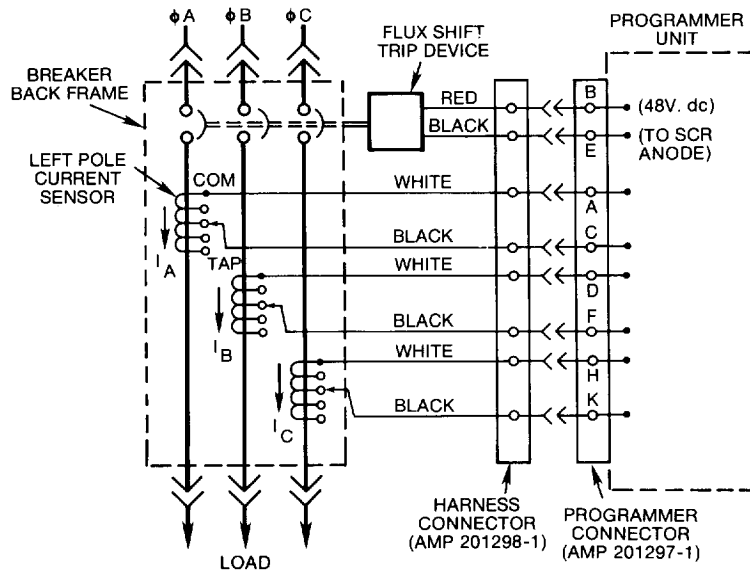

Fig. 25. Cabling Diagram - SST without ground fault

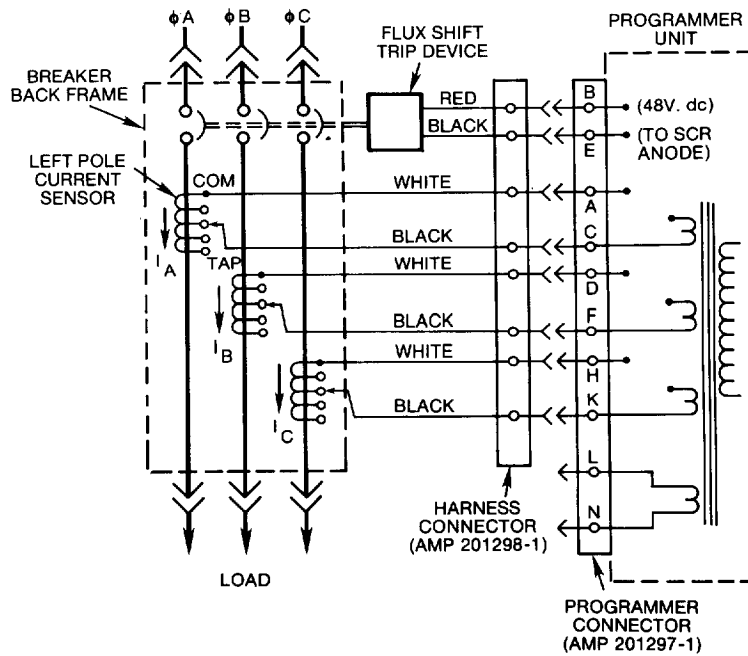

Fig. 26. Cabling Diagram - SST with ground fault on 3-wire load

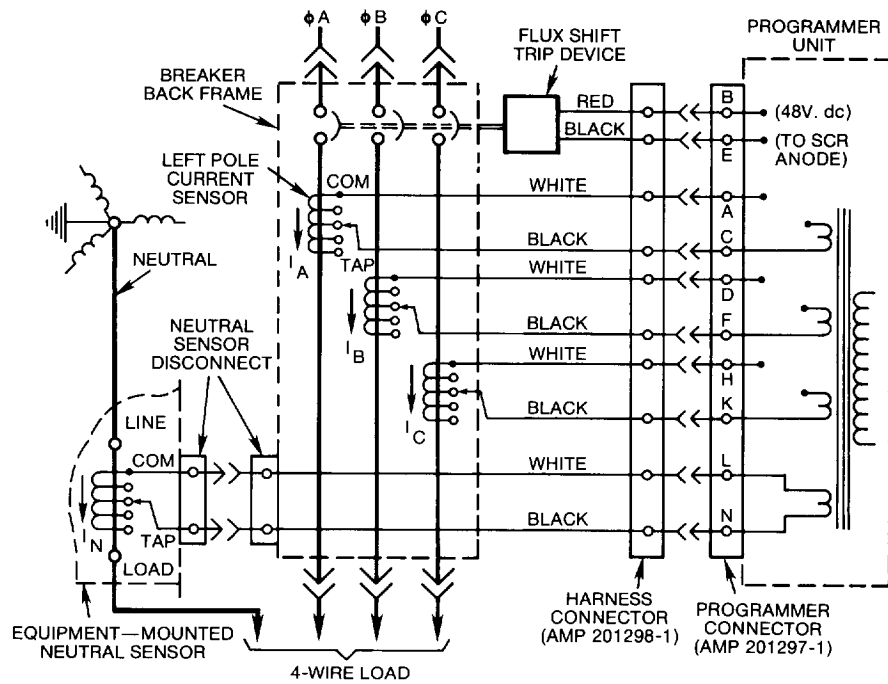

Fig. 27. Cabling Diagram - SST with ground fault on 4-wire load

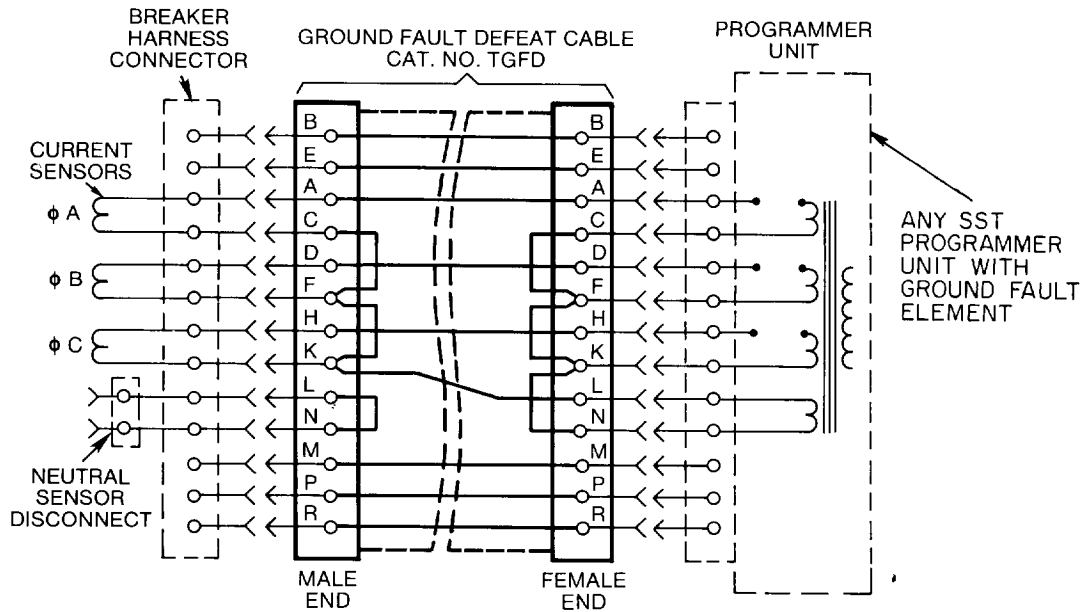

Fig. 28. Cabling diagram with Ground Fault Defeat Cable inserted between breaker harness and SST Programmer Unit - for use during single-phase, high current - low voltage testing.

TYPE ECS OVERCURRENT TRIP DEVICE

The ECS is a solid-state, direct-acting, self-powered trip device system that essentially duplicates SST except for the following:

1. Programmer units are limited to combinations of Long Time, Short Time and Instantaneous trip elements only. The Ground Fault element is not available.
2. Fault indicators (trip targets) are not available.
3. Phase sensors are not tapped. As listed in Table 5, each sensor has only a single ampere rating. A different sensor is available for each of the tabulated ampere ratings, which span the same range as SST.
4. Neutral sensors are not required because there is no Ground Fault function.

In all other respects the ECS trip device system operates and can be treated identically to SST. This includes circuitry, size, construction, component location, programmer unit set points, performance characteristics, operating range, quality, reliability and the flux shift trip device. Use the same troubleshooting and test procedures for single-phase, high current-low voltage tests or those employing the TAK-TS1 Test Set. The Ground Fault test procedures, of course, do not apply.

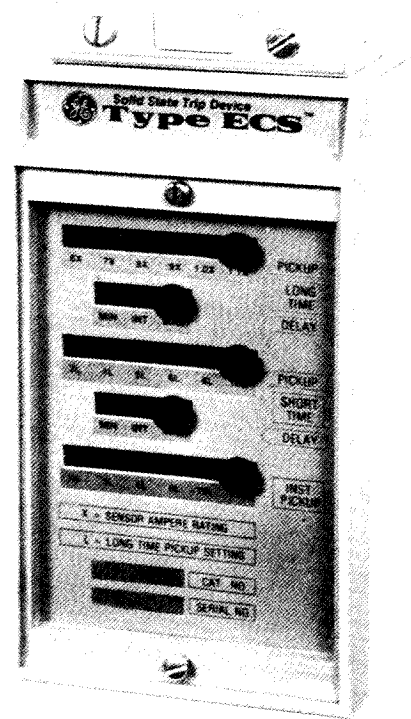

Fig. 29. ECS Programmer unit

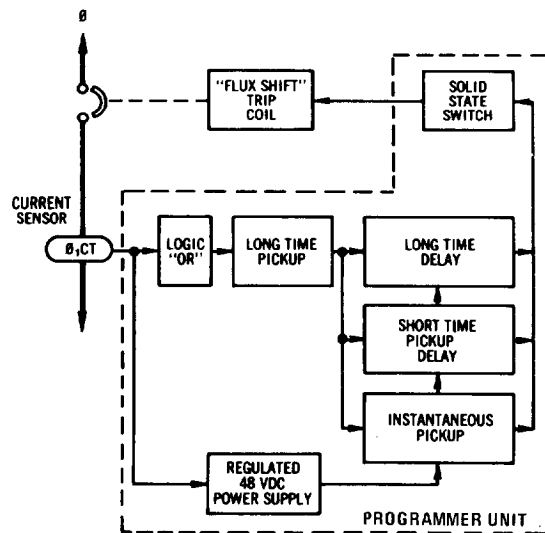

Fig. 30. ECS Block diagram

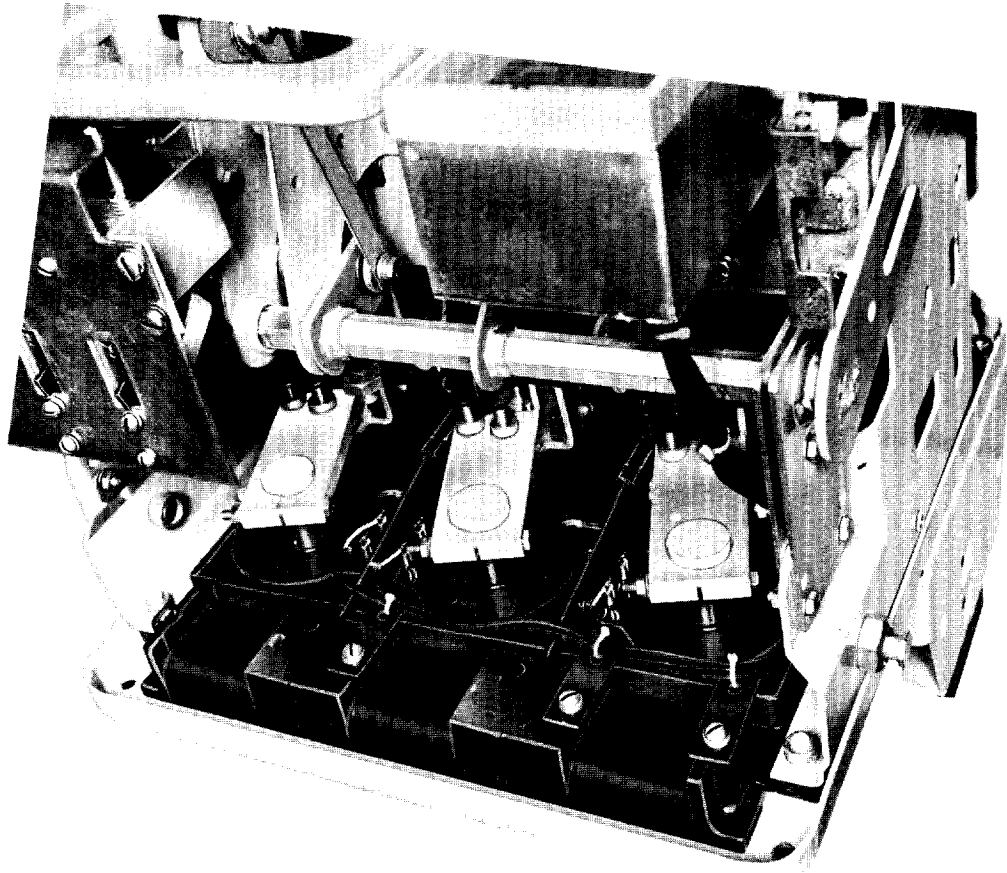

Fig. 31. ECS current sensors on AKRU-4A-30 breaker

**TABLE 5
ECS TRIP CHARACTERISTICS**

Breaker Type	Frame Size (Amperes)	X = Trip Rating in Amperes = Sensor Rating (Sensor Ampere Rating)	ECS PROGRAMMER ADJUSTMENT RANGE (Set Points)				Instantaneous Pickup (Multiple of L)
			Long Time		Short Time		
			Pickup (=L) ① (Multiple of X)	Time Delay Band ③ (Seconds)	Pickup ② (Multiple of L)	Time Delay Band ④ (Seconds)	
AKR-30	800	100, 150, 225, 300, 400, 600, 800	.6, .7, .8, .9, 1.0, 1.1 (X)	Maximum 22	3, 4, 5, 6, 8, 10 (L)	Maximum 0.35	4, 5, 6, 8, 10, 12 (L)
AKR-50	1600	300, 400, 600, 800, 1200, 1600		Intermed. 10	—or—	Intermed. 0.21	
AKRT-50	2000	800, 1200, 1600, 2000		Minimum 4	1.75, 2, 2.25, 2.5, 3, 4 (L)	Minimum 0.095	

① Pickup tolerance is $\pm 9\%$

② Pickup tolerance is $\pm 10\%$

③ Time delay shown at 600% of long time pickup setting (6L), at lower limit of band.

④ Time delay shown at lower limit of band.

(See page 27 for time-current curves)

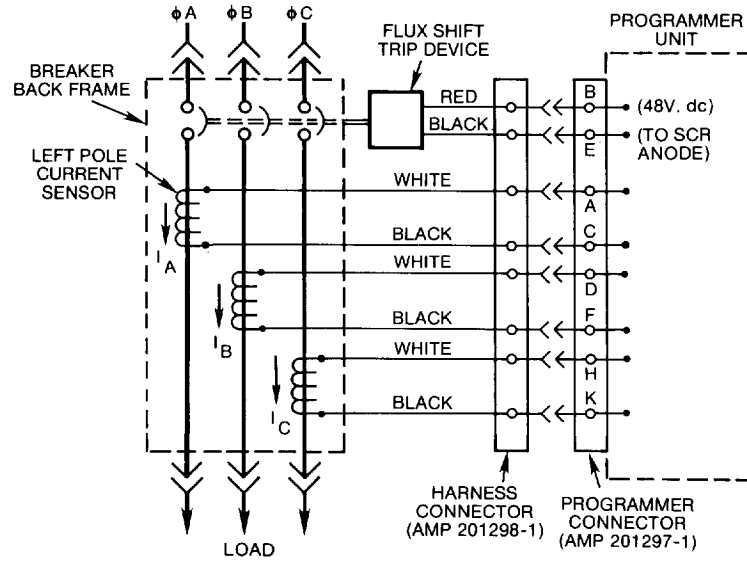

Fig. 32. Cabling diagram for ECS Trip Device

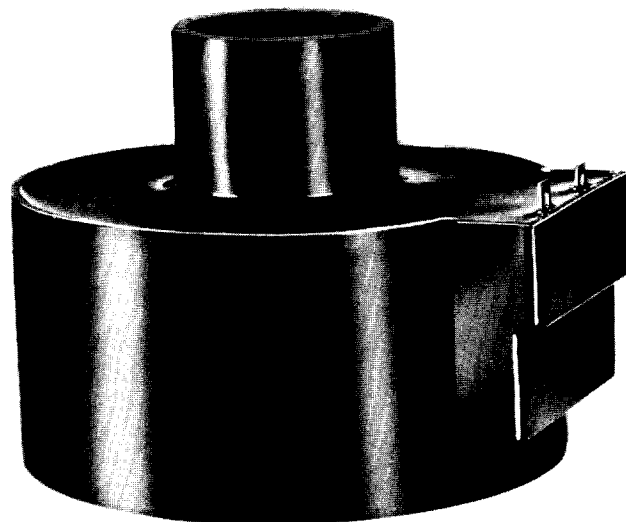
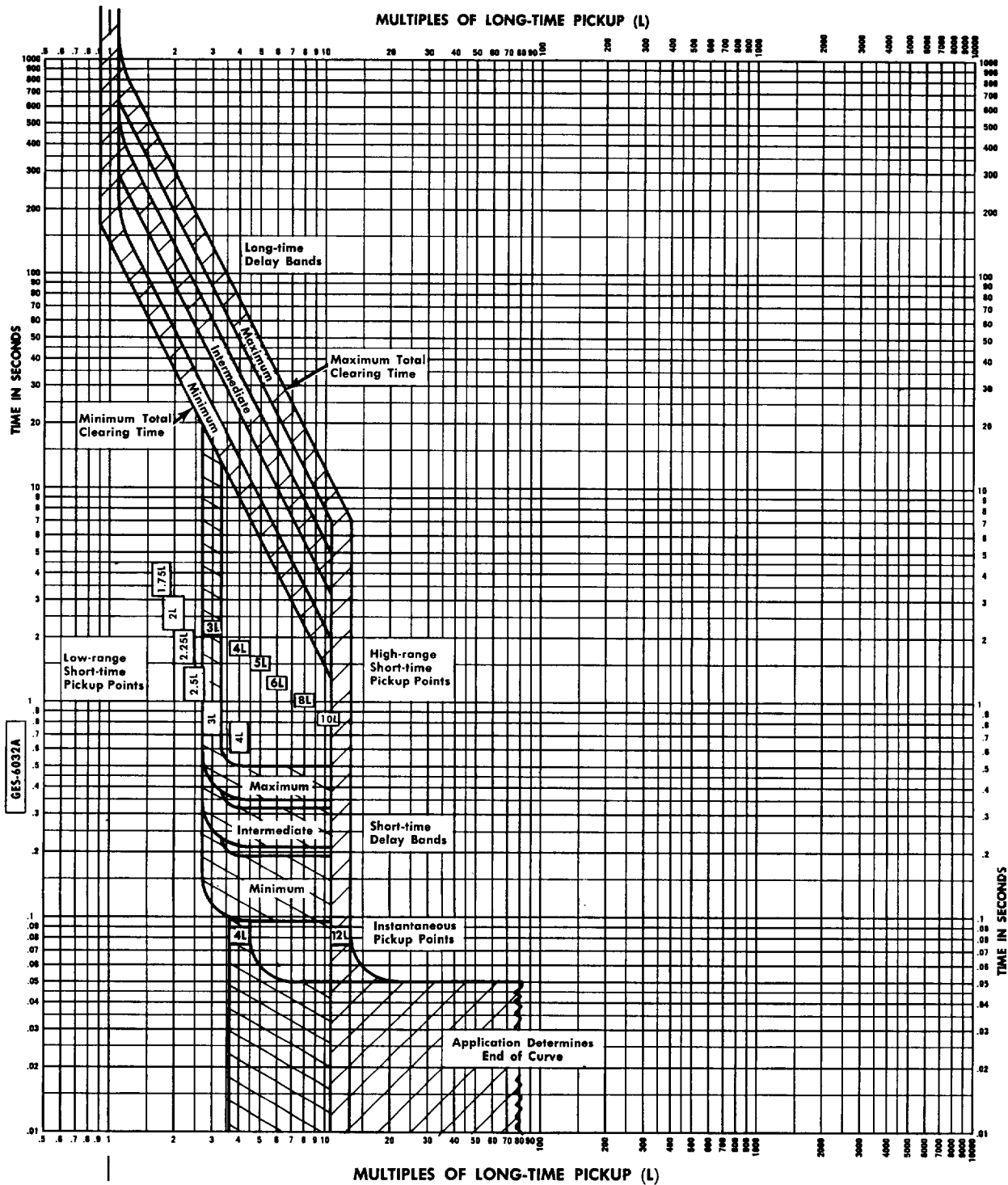

Fig. 33. ECS current sensor



NOTE: Short-time delay is optional. Instantaneous can be omitted.

GENERAL ELECTRIC X = Current Sensor Rating (Amperes) AKR-30 100, 150, 225, 300, 400, 600, 800 AKR-50 300, 400, 600, 800, 1200, 1600 AKRT-50 800, 1200, 1600, 2000 AK-75 1200, 1600, 2000, 3000 AKR-75 1200, 1600, 2000, 3000, 3200 AK/AKR-100 1600, 2000, 3000, 4000	AK/AKR LOW-VOLTAGE POWER CIRCUIT BREAKERS ECS™ SOLID-STATE OVERCURRENT-TRIP DEVICE Long-time-delay, Short-time-delay and Instantaneous Time-current Curves Curves apply at 50/60 Hertz From -20C to +70C Programmer Ambient	GES-6032A Programmer Set Points PICKUP Long-time: .6, .7, .8, .9, 1.0 & 1.1 multiples of current sensor rating (X). (Settings higher than 100% of the frame size do not increase the continuous current rating.) Short-time: 1.75, 2, 2.25, 2.5, 3, 4 or 3, 4, 5, 6, 8 & 10 multiples of Long-time pickup setting (L). Instantaneous: 4, 5, 6, 8, 10 & 12 multiples of Long-time pickup setting (L). TIME DELAY BANDS Long-time and Short-time: Max., Int. & Min.
--	--	---

12-77 (5M)

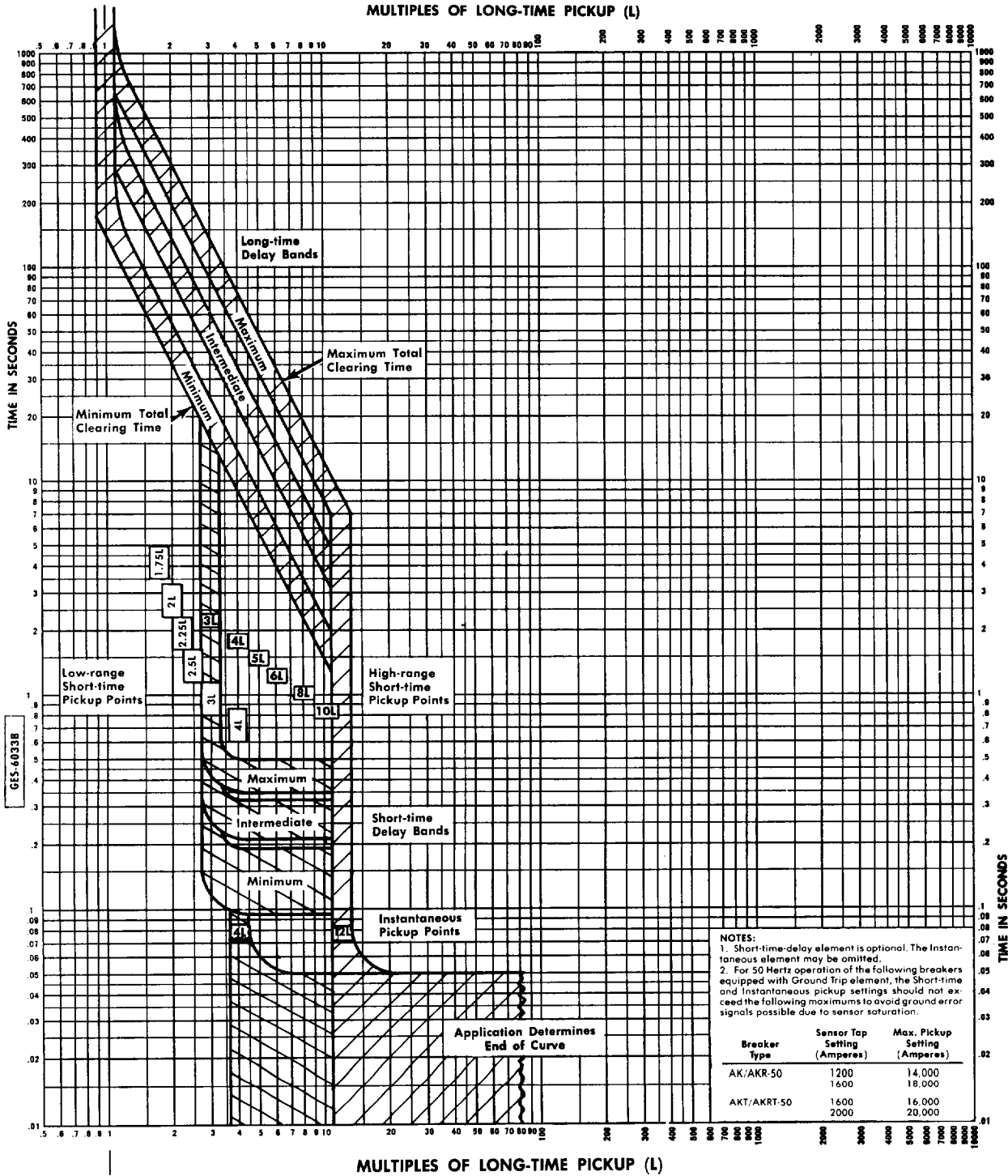

GENERAL ELECTRIC X = Current Sensor Taps (Amperes) AK-15 70, 100, 150, 225 AK-25 70, 100, 150, 225 or 300, 300, 400, 600 AKR-30 100, 150, 225, 300 or 300, 400, 600, 800 AK/AKR-50 300, 400, 600, 800 or 600, 800, 1200, 1600 AKT/AKRT-50 800, 1200, 1600, 2000 AK-75 1200, 1600, 2000, 3000 AKR-75 1200, 1600, 2000, 3200 AK/AKR-100 1600, 2000, 3000, 4000	AK/AKR LOW-VOLTAGE POWER CIRCUIT BREAKERS SST™ SOLID-STATE OVERCURRENT TRIP DEVICE Long-time-delay, Short-time-delay and Instantaneous Time-current Curves Curves apply at 50/60 Hertz From - 20C to + 70C Programmer Ambient	GES-6033B Programmer Set Points PICKUP Long-time: 6, 7, 8, 9, 1.0 & 1.1 multiples of current sensor tap setting (X). (Settings higher than 100% of the frame size do not increase the continuous current rating). Short-time: 1.75, 2, 2.25, 2.5, 3 & 4 or 3, 4, 5, 6, 8 & 10 multiples of Long-time pickup setting (L). For 50 Hz operation, see Note 2. Instantaneous: 4, 5, 6, 8, 10 & 12 multiples of long-time pickup setting (L). For 50 Hz operation, see Note 2. TIME DELAY BANDS Long-time and Short-time: Max., Int. & Min.
--	--	--

2-78 (13M)

GENERAL ELECTRIC CO. DISTRIBUTION EQUIPMENT DIVISION, PLAINVILLE, CONN. 06062

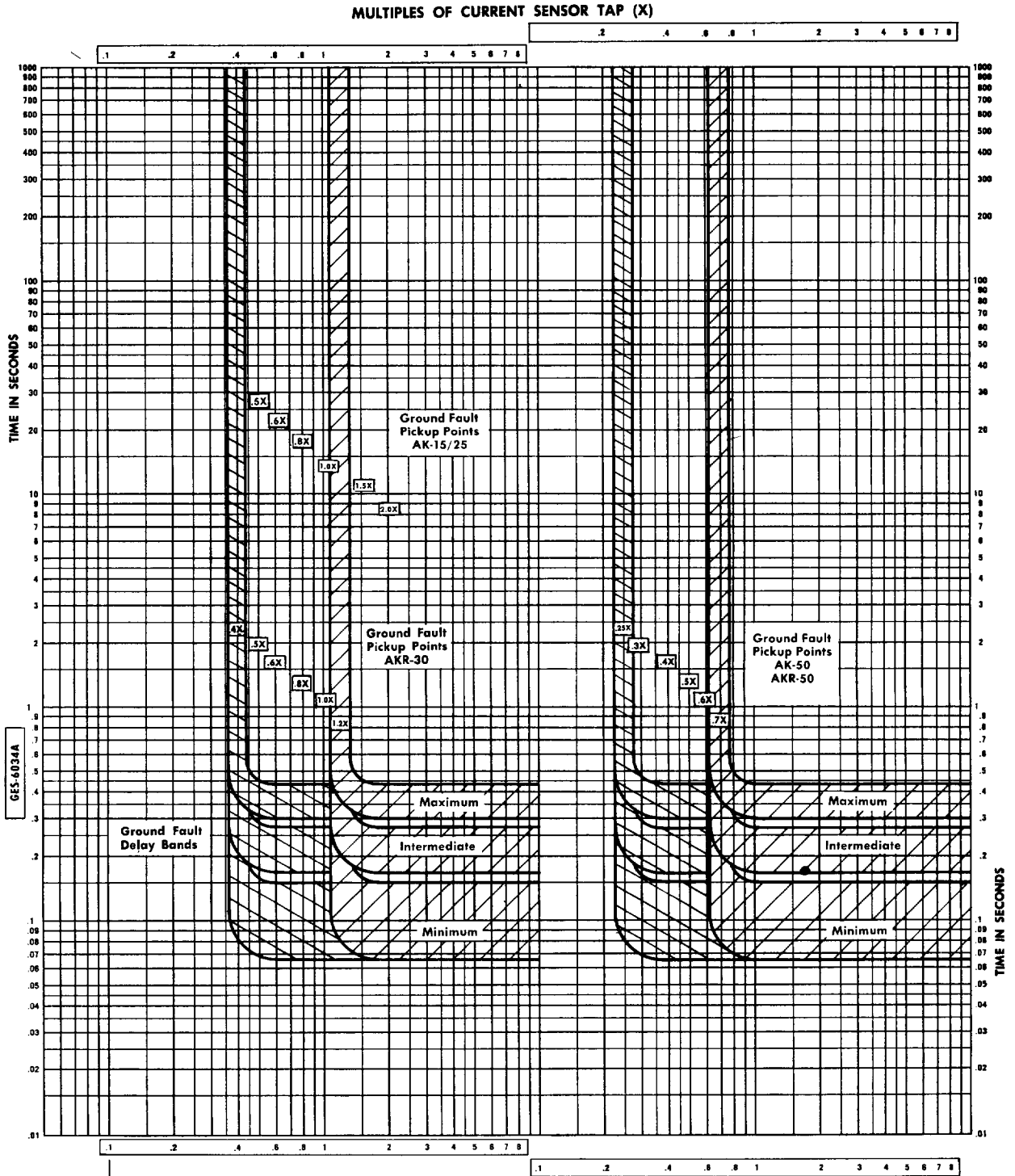

NOTE: 4th wire Ground sensor tap must be set same as phase sensor tap.

<p>GENERAL ELECTRIC</p>	<p>TYPE AKR LOW-VOLTAGE POWER CIRCUIT BREAKERS</p>		<p>GES-6034A</p>
	<p>SST™ SOLID-STATE OVERCURRENT TRIP DEVICE</p>		
<p>Current Sensor Taps (Amperes)</p>	<p>Ground Trip Time-current Curves</p>		<p>Programmer Set Points</p>
<p>AK-15 70, 100, 150, 225</p> <p>AK-25 70, 100, 150, 225 or 200, 300, 400, 600</p> <p>AKR-30 100, 150, 225, 300 or 300, 400, 600, 800</p> <p>AK/AKR-50 300, 400, 600, 800 or 600, 800, 1200, 1600</p>	<p>Curves apply at 50/60 Hertz From -20C to +70C Programmer Ambient</p>		<p>Ground Fault Pickup: AK-15/25 .5x, .6x, .8x, 1.0x, 1.5x, & 2.0x AKR-30 .4x, .5x, .6x, .8x, 1.0x, & 1.2x AK/AKR-50 .25x, .3x, .4x, .5x, .6x, & .7x Where X = sensor tap setting</p> <p>Ground Fault Delay Bands: Maximum, Intermediate & Minimum</p>

2-78 (3M)

GENERAL ELECTRIC CO., DISTRIBUTION EQUIPMENT DIVISION, PLAINVILLE, CONN. 06062

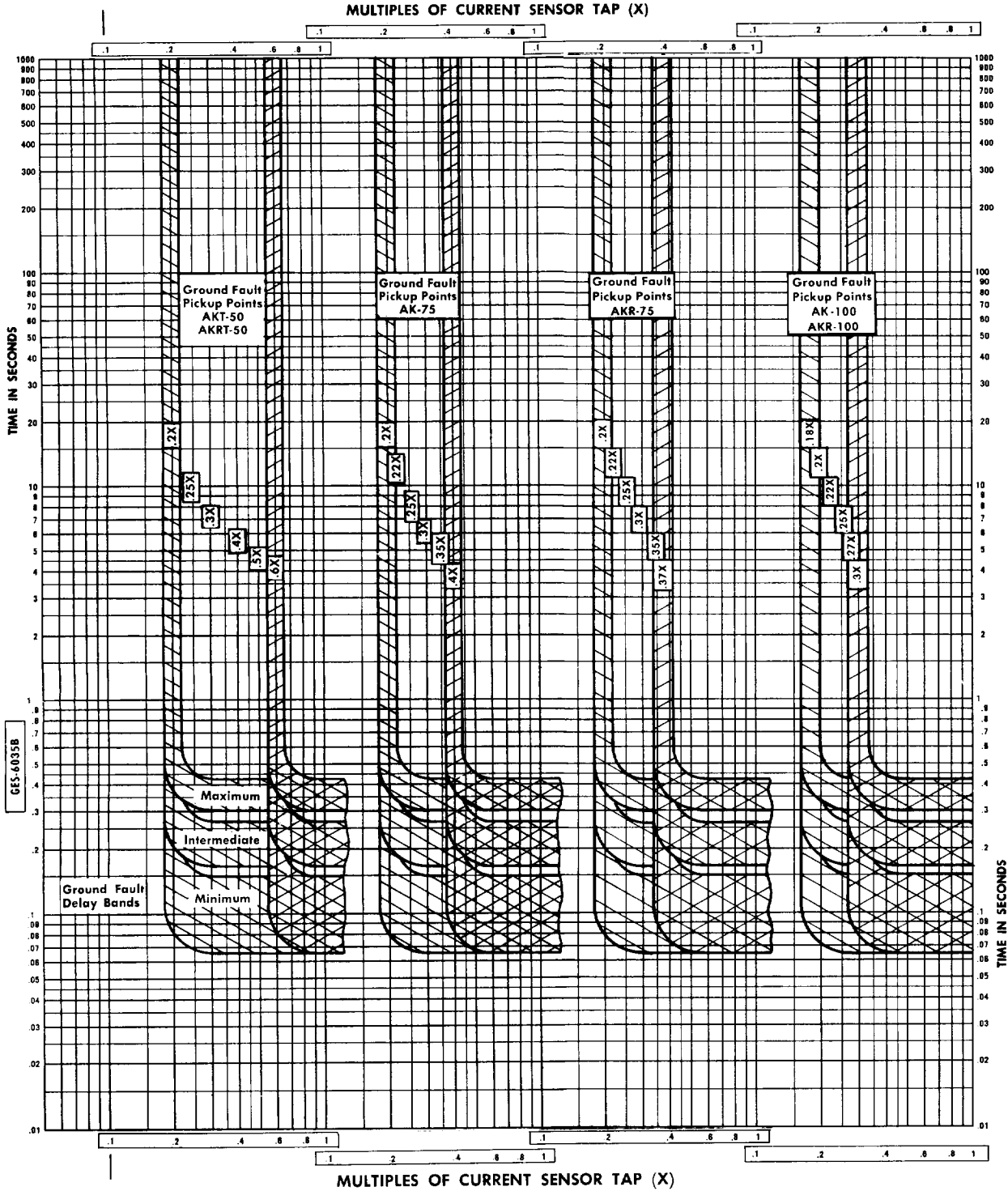

NOTE: 4th wire Ground sensor tap must be set same as phase sensor tap.

<p>GENERAL ELECTRIC</p>	<p>AK/AKR LOW-VOLTAGE POWER CIRCUIT BREAKERS</p> <p>SST™ SOLID-STATE OVERCURRENT TRIP DEVICE</p> <p>Ground Trip Time-current Curves</p> <p><small>Curves apply at 50/60 Hertz From -20C to +70C Programmer Ambient</small></p>	<p>GES-6035B</p> <p>Programmer Set Points</p> <p>Ground Fault Pickup: AKT/AKRT-50 .2x, .25x, .3x, .4x, .5x, & 6x AK-75 .2x, .22x, .25x, .3x, .35x, & 4x AKR-75 .2x, .22x, .25x, .3x, .35x & .37x AK/AKR-100 .18x, .2x, .22x, .25x, .27x & .3x Where X = sensor tap setting</p> <p>Ground Fault Delay Bands Maximum, Intermediate & Minimum</p>								
<p>X = Current Sensor Taps (Ampere)</p> <table border="0"> <tr> <td>AKT AKRT-50</td> <td>800, 1200, 1600, 2000</td> </tr> <tr> <td>AK-75</td> <td>1200, 1600, 2000, 3000</td> </tr> <tr> <td>AKR-75</td> <td>1200, 1600, 2000, 3200</td> </tr> <tr> <td>AK AKR-100</td> <td>1600, 2000, 3000, 4000</td> </tr> </table>	AKT AKRT-50	800, 1200, 1600, 2000	AK-75	1200, 1600, 2000, 3000	AKR-75	1200, 1600, 2000, 3200	AK AKR-100	1600, 2000, 3000, 4000		
AKT AKRT-50	800, 1200, 1600, 2000									
AK-75	1200, 1600, 2000, 3000									
AKR-75	1200, 1600, 2000, 3200									
AK AKR-100	1600, 2000, 3000, 4000									

2-78 (11M)

GENERAL ELECTRIC CO. DISTRIBUTION EQUIPMENT DIVISION, PLAINVILLE, CONN. 06062

For further information
call or write your local
General Electric
Sales Office or . . .

Distribution Equipment
Division
41 Woodford Avenue
Plainville, CT 06062, USA
