

**LOW-VOLTAGE POWER CIRCUIT BREAKERS
INSTALLATION AND OPERATION MANUAL**

AKS-50
(Replacement for AK50)

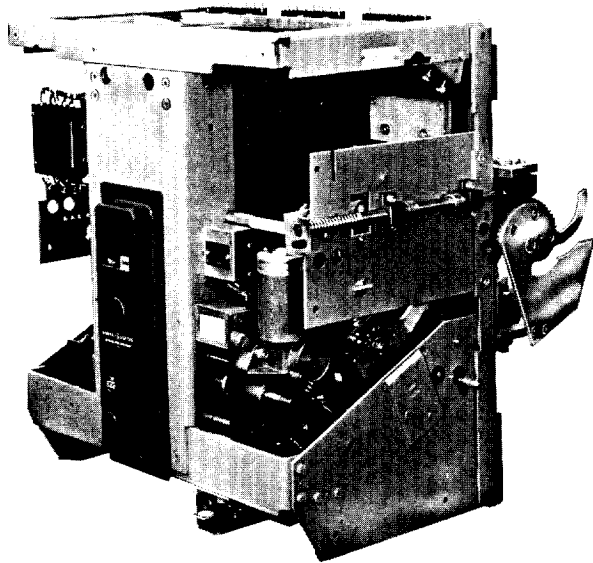

AKS-2-50 (AKD Type)

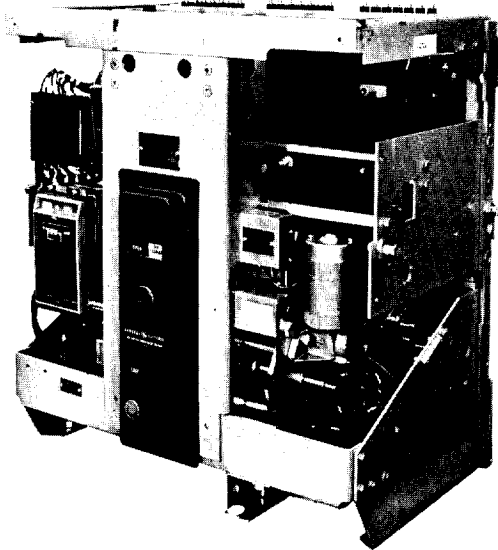

AKS-5A-50 (AKD-5 Type)

INSTALLATION AND OPERATION OF TYPE AKS-50 LOW-VOLTAGE POWER CIRCUIT BREAKERS

CONTENTS

| | Page |
|---|------|
| INTRODUCTION | 3 |
| RECEIVING, HANDLING AND STORAGE | 4 |
| INSTALLATION | 4 |
| Location | 4 |
| Mounting Types | 4 |
| Stationary Breakers | 4 |
| Drawout Breakers | 5 |
| CONNECTIONS | 9 |
| OPERATION | 10 |
| Manual Closing | 10 |
| Electrical Closing | 10 |
| Tripping | 11 |
| FUSED BREAKERS | 11 |
| MAINTENANCE | 11 |
| Reference Publications | 12 |
| Current Rating of Auxiliary Devices | 12 |

These instructions do not purport to cover all details or variations in equipment nor to provide for every possible contingency to be met in connection with installation, operation or maintenance. Should further information be desired or should particular problems arise which are not covered sufficiently for the purchaser's purposes, the matter should be referred to the General Electric Company.

INTRODUCTION

These instructions describe the installation and operation of the AKS-50 frame size Low Voltage Power Circuit Breakers. They cover a variety of models which may differ in rating, trip device and/or mounting type as indicated in Table 1.

TABLE 1 BREAKER DESIGNATIONS

| FRAME SIZE (Amperes) | | | | DRAWOUT MOUNTING | | STATIONARY MOUNTING | NOTES |
|-------------------------|----------|----------|-------|---------------------------|-----------------------------|-----------------------------|-------|
| 250V. Dc | 500V. Dc | 600V. Ac | POLES | AKD | AKD-5 | | |
| 2000 | — | 1600 | 3 | AKS-(*)-50 AKS-(*)-50H | AKS-(*)A-50 AKS-(*)A-50H | AKS-(*)S-50 AKS-(*)S-50H | (1) |
| — | 2000 | — | 2 | AKS-(*)-50V | AKS-(*)A-50V | AKS-(*)S-50V | (2) |
| — | — | 2000 | 3 | AKST-(*)-50H | AKST-(*)A-50H | AKST-(*)S-50H | (1) |
| — | — | 1600 | 3 | AKSU-(*)-50 | AKSU-(*)A-50 | — | (3) |

- (1) The "H" suffix denotes extended short circuit ratings.
- (2) The "V" suffix denotes 500V. Dc ratings.
- (3) Integrally fused models.

(*) This digit identifies the trip device type as follows:

2 = EC-1 or EC-2A (Dc only).

4 = ECS } (50/60 Hertz only)

5 = SST }

N = Non-automatic. In addition, all non-automatic 250 VDC breaker types carry the suffix letter D after their frame number, e.g., AKS-N-50D.

EC-1 & EC-2A trip devices are the electro-mechanical type. ECS and SST units are Solid State. For detailed information on these trip devices refer to the following publications:

ECS, SST GEI-86156

EC-1, EC-2A..... GEI-86157

RECEIVING, HANDLING AND STORAGE

Before installing or operating these circuit breakers, carefully read these instructions.

Upon receipt of a circuit breaker, immediately examine for any damage or loss sustained in shipment. If injury, loss or rough handling is evident, file a damage claim at once with the transportation company and notify the nearest General Electric Sales Office.

Unpack the circuit breaker as soon as possible after it has been received. Exercise care in unpacking to avoid damage to the breaker parts. Be sure that no loose parts are missing

or left in the packaging material. Blow out any dirt or loose particles of packaging material remaining on or in the breaker.

If the circuit breaker is not to be placed in service at once, store it in a clean, dry location in an upright position. Support it to prevent bending of the studs or damage to any of the breaker parts. Do not cover the breaker with packing or other material which absorbs moisture that may cause corrosion of breaker parts. A covering of kraft or other non-absorbent paper will prevent dust from settling on the breaker.

INSTALLATION

LOCATION

In choosing a location for the installation of these breakers there are two factors to be considered. The first is the location's environmental impact on the breaker. Much better performance and longer life can be expected if the area is clean, dry, dust-free and well ventilated. The second is convenience for operation and maintenance. The breaker should be easily accessible to the operator and there should be sufficient space available for maintenance work.

MOUNTING TYPES

AKS breakers are furnished in both drawout and stationary construction. The mounting type is identified by the second middle digit in the breaker's nameplate designation as follows:

AKS-4(†)-50, where
 (†) = mounting type

TABLE 2 MOUNTING TYPE CODE

| (†) Code Letter | Breaker Type | |
|-----------------|--------------|------------|
| | Drawout | Stationary |
| None | AKD | ---- |
| A | AKD-5 | ---- |
| S | ---- | 22" (wide) |

STATIONARY BREAKERS

These breakers are designed for mounting in a switchboard or enclosure designed and constructed by others. Mounting consists of bolting the breaker frame to a supporting structure within the switchboard or enclosure, connecting the power buses or cables, and making any necessary control connections. The front cover of the breaker enclosure may be a hinged door or a plate bolted to the panel, including a cut-out opening through which the front escutcheon of the breaker can protrude.

The surface on which the breaker is mounted must be flat to avoid internal distortion of the breaker. The supporting structure must be rigid enough to avoid any possibility of the breaker studs supporting the weight of the breaker. Minimum cutout dimensions as given by the appropriate outline drawing must be maintained to provide adequate electrical clearance. Connecting bus and cables must be rigidly supported to prevent undue stress on the breaker terminals.

The outline drawings in Table 3 provide basic dimensional information for designing the panel or enclosure mounting.

TABLE 3

| Stationary Breaker Type | Outline Drawing | |
|-------------------------|-------------------|-----------------------|
| | Manually Operated | Electrically Operated |
| AKS-()S-50 | 139C4931 | 139C4932 |
| AKS-()S-50H | | |
| AKS-()S-50D | | |
| AKS-()S-50V | | |
| AKST-()S-50H | | |

DRAWOUT BREAKERS

GENERAL

Drawout breakers are manufactured in two different styles, identified in Table 2 by the mounting code letters. The "no letter" models are used in General Electric's AKD Switchgear. Code A models are used in AKD-5 equipment and feature closed-door drawout operation. The construction and operation of each of these drawout styles is covered under respective headings in the following text.

As a general rule, breakers of the same drawout type, voltage rating and ampere frame size are physically interchangeable. However, to be electrically interchangeable with respect to secondary and control circuits, they must have duplicate wiring.

NOTE: *The two drawout types are mutually non-interchangeable; before insertion is attempted, verify that the breaker model matches its intended compartment.*

NO CODE LETTER (AKD SWITCHGEAR) (Fig. 1)

The "no letter" AKS model replaces the AK-50 in AKD switchgear. The racking mechanism is breaker-mounted and the breakers are bolted to a roller-mounted tray which is part of the switchgear. The AKD drawout has the following unique aspects.

1. There are three (3) distinct drawout positions — CONNECTED, TEST and WITHDRAWN.
2. Racking travel occurs only between the CONNECTED position and a point just short of reaching the TEST position.
3. The compartment door must be open during racking.

Breaker Insertion (AKD Type)

1. Prior to lifting a breaker to its intended compartment location, observe the following precautions:
 - a. *Check the compartment to insure that it is free of foreign objects.*
 - b. *Verify that the breaker is the correct type for that compartment.*
 - c. *Insure that the breaker is OPEN.*
 - d. *Apply a thin, fresh coat of D50HD38 (Mobil 28) lubricant to the breaker's primary disconnects.*
 - e. *Insure that the racking cams on the breaker are correctly positioned for initial engagement with the pins in the compartment. To do this, insert the racking handle and rotate it fully clockwise.*
 - f. *If a compartment contains a keylock, it will not accept the AKS replacement breakers as received. The AKS*

drawout mechanism differs from that of its predecessor AK model, causing the AKS breaker to mechanically interfere with the keylock during breaker insertion. To remedy this it will be necessary to relocate the keylock using new mounting hardware included as a modification kit #343L756G1. So altered, the compartment accepts both AK and AKS types.

2. Using a suitable lifting mechanism and spreader rig, position lifting hooks at the cutout notches in the top wrap-around frames of the breaker. Exercise care to avoid damage to the control wiring.

3. Open the compartment door. Keeping the rollout tray positioned inside the compartment, raise the breaker above the elevation of the tray.

4. Depress the test position stop lever and pull the tray all the way out to its WITHDRAWN position.

5. Lower the breaker over the tray until it is about one-half inch above the two dowel pins on the tray. Push the breaker back into the compartment until the rear bottom flange of the breaker rests against the guides behind the dowel pins.

6. Slowly lower and guide the breaker onto the tray so the holes in the rear flange fit over the two dowel pins. When correctly positioned on the dowel pins, the breaker's rear and side bottom flanges will rest firmly on the tray.

7. Secure the breaker to the tray by inserting and tightening two- $\frac{3}{8}$ inch hex-head screws into the front holes of its side flanges.

8. If the breaker is a manually operated type, push it into the compartment until the TEST position stop engages, preventing further travel. The breaker is now in the TEST position.

If the breaker is electrically operated, push it into the compartment until the spring discharge stop is encountered. Release this by depressing the "spring discharge" lever on the bottom of the breaker (see fig. 1), then continue pushing the breaker into the compartment until the TEST position stop engages.

NOTE: *A spring discharge stop will not be present in some AKD-type compartments originally furnished for electrically operated AK-50 of the non-quick-close type.*

9. Depress the TEST position stop lever and push the breaker farther into the compartment until the outer surfaces of the racking cams butt against the racking pins in the housing.

10. Insert the racking handle 193A1990P1 on the jack-screw shaft at the upper right side of the breaker. Rotate it clockwise until the jackscrew comes to a solid stop. The breaker is now in the CONNECTED position.

Breaker Removal (AKD Type)

1. With the door closed and latched, trip the breaker.
2. Open the door and insert the racking handle on the jackscrew shaft. Rotate it counterclockwise until the jack-screw comes to a solid stop. At this point the primary disconnects are disengaged.
3. Now pull the breaker out of its compartment until the test position stop engages, thereby holding the breaker in the TEST position.
4. To withdraw a manually operated breaker from TEST, depress the test position stop lever and pull the breaker out of its compartment until the tray stops. At this position the tray will be fully withdrawn against its limit stop.
The withdrawal movement for electrically operated breakers differs from the above in that the tray is stopped short of its WITHDRAWN limit by the compartment-mounted spring discharge stop. In order to complete the withdrawal, the closing springs first must be discharged by depressing the spring discharge lever on the breaker. Next, keeping this lever depressed, pull the breaker completely out against the tray limit stop. A ramp cam mounted on the compartment wall keeps the breaker trip-free during the outward travel from the TEST position.

5. Before proceeding with subsequent operations to remove the breaker from the tray, visually check the breaker's CHARGED-DISCHARGED and OPEN-CLOSED indicators to verify that the breaker is open and the springs are discharged. This precaution is particularly important at locations where AKS-50 breakers are being deployed in AKD equipment as replacements for AK-50 non-quick-close electrical models; these compartments do not need and were not equipped with a spring discharge stop.
6. Remove the two-3/8 inch hex-head screws which fasten the breaker to the compartment tray.
7. Using care to prevent damage to the wiring, attach the lifting device to the cutout notches in the top wraparound frame of the breaker.
8. Lift the breaker approximately one-half inch off the dowel pins. Push the tray back into the compartment.
9. Swing the breaker forward until the primary disconnects clear the compartment. Lower the breaker onto a flat surface free of protrusions that could damage the breaker's internal parts.

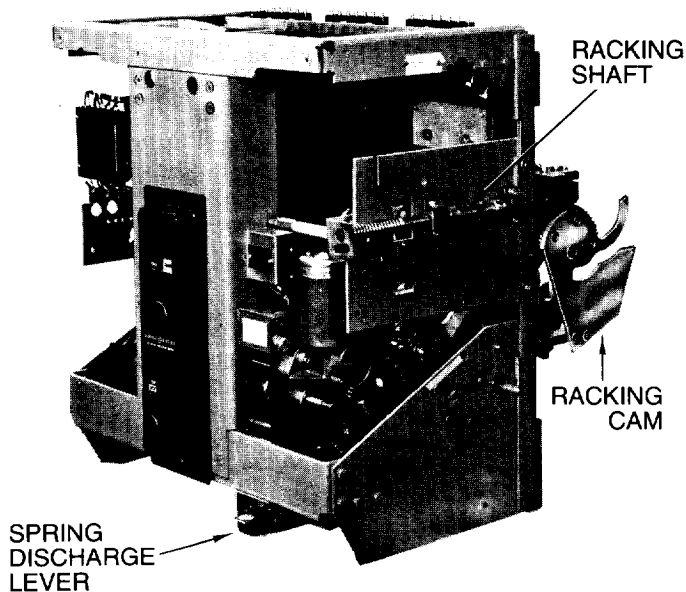

| AKD TYPE | | |
|---|----------|--------------|
| Outline Drawings | | |
| | Manually | Electrically |
| AKS()-50 AKS()-50H AKS()-50D AKS()-50V | 139C4919 | 139C4920 |
| AKST()-50 AKST()-50H | 139C4921 | 139C4922 |
| AKSU-()-50 | 139C4923 | 139C4924 |

Fig. 1 AKS-2-50 electrically operated (AKD type)

CODE A (AKD-5 SWITCHGEAR) (Fig. 2)

The drawout mechanism is equipment mounted and is externally operated by a removable racking handle. The breaker is supported by two pins protruding from each side of its frame, these engaging slots in telescoping rails fastened to the compartment walls.

The drawout operation features four positions — CONNECTED, TEST, DISCONNECTED and WITHDRAWN. In the CONNECTED position the primary and secondary disconnects are fully engaged. The breaker must be tripped before it can be racked into or out of this position. In the TEST position the primary contacts are disconnected but the secondary contacts remain engaged. This allows complete breaker operation without energizing the primary circuit. In the DISCONNECTED position neither primary nor secondary contacts are made. Breakers can be racked between these three positions with the compartment door closed. Each position is clearly identified by a rotary indicator visible through an opening in the door.

With the door open, the breaker is manually pulled out from the DISCONNECTED to the WITHDRAWN position; here the breaker is completely out of its compartment, ready for removal.

NOTE: All electrically operated AKS-50 breakers employ a spring discharge interlock which prevents removal of the breaker with its closing springs in the charged state. Before the breaker can be moved away from the DISCONNECTED position toward the WITHDRAWN position, it is necessary to depress and hold the breaker-mounted spring discharge lever (Fig. 2). This discharges the closing springs and releases the breaker.

Manually operated breakers do not require this interlock because their closing springs are never propped in the fully charged position. Refer to the "Manual Closing" text on page 10.

Breaker Insertion (Code A)

1. Prior to lifting a breaker to its intended compartment location, observe the following precautions:
 - a. Check the compartment to insure that it is free of foreign objects.
 - b. Verify that the breaker is the correct type for that compartment.
 - c. Insure that the breaker is OPEN.
 - d. Apply a thin, fresh coat of D50HD38 lubricant to the breaker's primary disconnects.

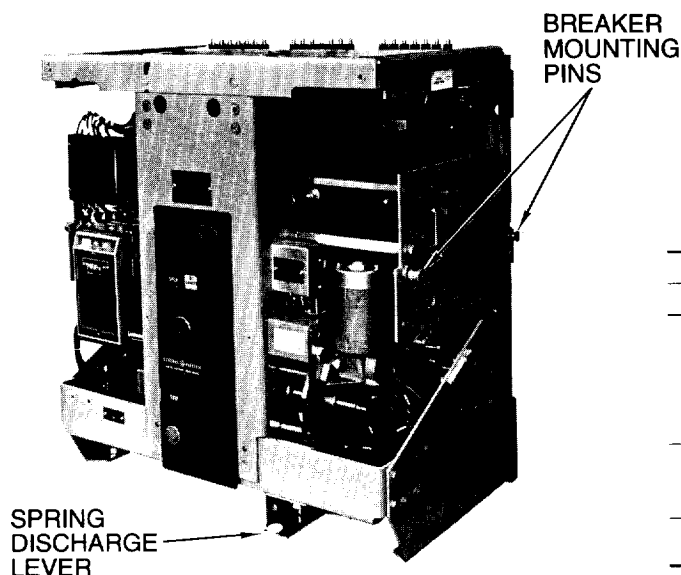

| AKD-5 TYPE | | |
|---|------------------|--------------|
| | Outline Drawings | |
| | Manually | Electrically |
| AKS()A-50 AKS()A-50H AKS()A-50D AKS()A-50V | 139C4925 | 139C4926 |
| AKST()A-50 AKST()A-50H | 139C4927 | 139C4928 |
| AKSU()A-50 | 139C4929 | 139C4930 |

FIG. 2 AKS-5A-50 electrically operated (AKD-5 type)

2. With the movable inner housing of the compartment in the CONNECTED position, insert the racking handle (part no. 193A1990P1) on the jackscrew shaft located at the left side of the compartment just above the position indicator.

3. Rotate the handle counterclockwise until the jackscrew stops — the indicator should read DISC.

4. Remove the racking handle and open the compartment door.

5. Rotate the two track-lock links and pull the right track to the limit of its travel.

6. Using a lifting device, raise the breaker until the breaker mounting pins are approximately one-inch above the tracks. Use care to avoid damage to the breaker wiring.

7. Pull the left track out to the limit of its travel and lower the breaker so its mounting pins drop into the slots in the track. Remove the lifting device.

8. Push the breaker in against the track stops. On electrically operated breakers, be sure to depress the spring discharge lever while doing so. Rotate the two track-lock links to lock the breaker in place. Close the compartment door.

9. Insert the racking handle on the jackscrew shaft and rotate it clockwise to move breaker into the compartment. Breaker is in CONNECTED position when jackscrew stops. The indicator should read CONN.

10. Orient the jackscrew so that its slotted sleeve is free to move outward, otherwise the breaker will remain trip-free.

Breaker Removal (Code A)

1. Trip the breaker. Insert the racking handle into the jackscrew shaft.

2. Rotate the handle counterclockwise until the jackscrew stops. Indicator should read DISC.

3. Remove the racking handle and open the compartment door.

4. Rotate the two track-lock links and pull the breaker out to the track travel limit. This is the WITHDRAWN position. If the breaker is electrically operated, the breaker-mounted Spring Discharge lever must be depressed to permit withdrawal.

NOTE: *Spring discharge interlocks were not required and are not present in existing compartments originally furnished for non-quick-close type electrically operated AK-50 breakers. Regardless of whether this interlocking hardware is present in a compartment, ALWAYS verify that the closing springs are discharged and the breaker is tripped OPEN before removal is attempted.*

5. Attach lifting hooks at the cutouts in the top wrap-around frame and raise the breaker until its mounting pins clear the track slots.

6. Push the tracks into the compartment so that the breaker can be lowered to a smooth surface free of protrusions that could damage the internal parts of the breaker.

CONNECTIONS

In all electrical connections good joint conductivity is a must. When making power connections to stationary breakers, the mating joint surfaces must be clean and have a smooth finish. They should be parallel and firmly bolted or clamped together. In addition, the bus or cable conductors must have ample ampacity to prevent overheating.

Control Connections

The outgoing connections to a breaker's accessories and control devices must be in accordance with the specific wiring diagram applicable to that breaker.

Control connections to stationary breakers are made to a terminal board mounted on the breaker. Figure 3 shows typical closing and tripping connections. If equipped with an overcurrent trip device which includes a ground fault element for use on 4-wire circuits, an additional terminal board is provided on the breaker for connecting to the equipment-mounted neutral sensor (physically located in the neutral conductor).

On drawout breakers the control circuits terminate in the breaker compartment on the stationary portion of separable secondary disconnects — see fig. 4.

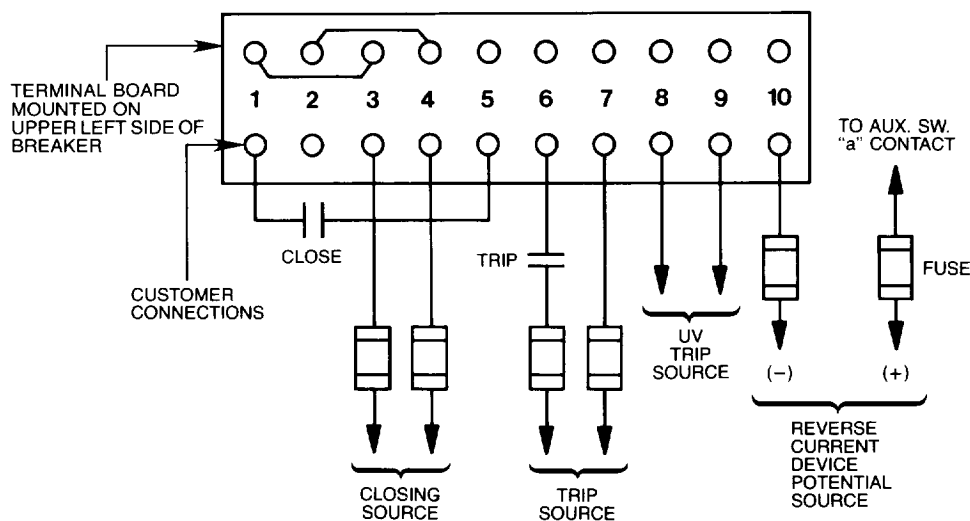

Fig. 3 Control connections to stationary breakers — front view.

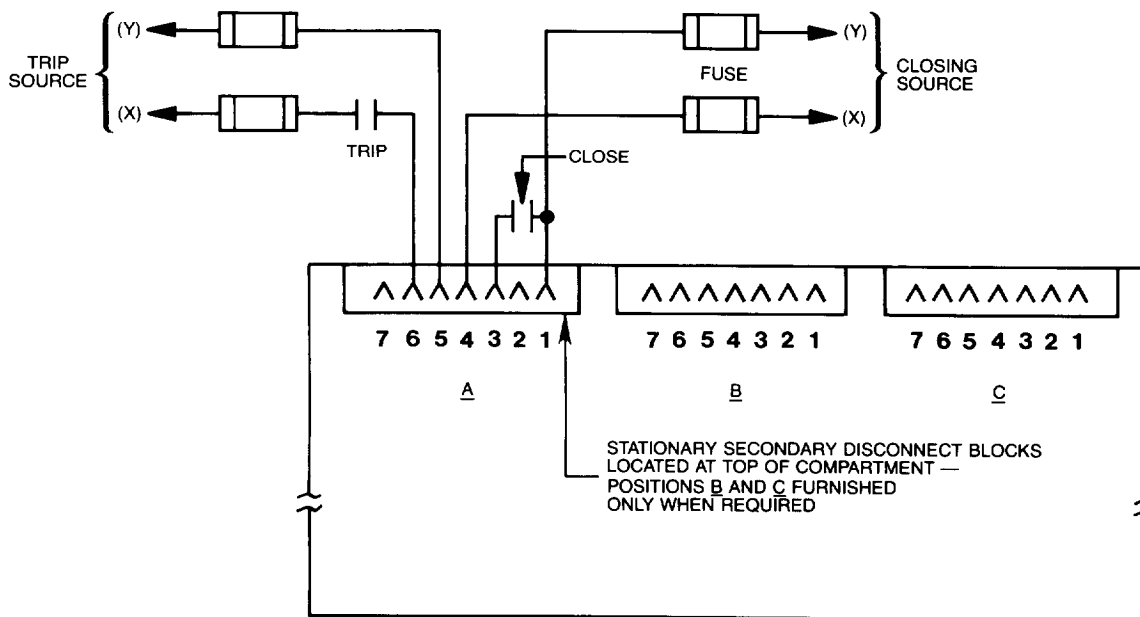

Fig. 4 Control connections to drawout breakers — front view of breaker compartment.

OPERATION

GENERAL

The AKS-50 breakers are closed by the discharging of the energy stored in the closing springs of the breaker. As the closing springs are discharged, the energy is directed into the closing cam of the breaker which causes the moveable breaker contacts to be forced against the stationary contacts, and, at the same time causes the opening springs to be charged so they may open the breaker during a subsequent opening operation.

MANUAL CLOSING

Manually operated breakers are equipped with a handle which extends from the escutcheon of the breaker. Alternately rotating the closing handle counterclockwise then clockwise through approximately 120 degrees of rotation through four complete cycles will cause the breaker to close. During the four counterclockwise movements and the first three clockwise movements of the handle, the springs are progressively charged. After approximately seven degrees travel of the fourth clockwise handle movement, the spring charge mechanism is driven "over center" and the energy stored in the closing springs is directed into the closing cam and causes the breaker to close. A charge-indicator, numbered one to four, visible through the breaker escutcheon, indicates the number of complete handle movements that have been performed.

ELECTRICAL CLOSING

On electrically operated breakers the closing springs are charged by a gear motor. With the springs discharged, voltage applied to the control circuit will energize the motor through the "G" switch contacts — see fig. 5. The motor, through the gear reduction output crank, compresses the closing springs until they are fully charged. As this fully charged position is reached, mechanically operated switches "F" and "G" reverse their shown position, the "G" switch deenergizing the motor and the "F" switch establishing a circuit to the "X" relay. At the same time, a mechanical prop is positioned to prevent the discharge of the fully charged closing spring.

With the closing spring propped fully-charged, the breaker is ready for closing. This may be accomplished electrically by depressing the closing switch on the breaker (if so equipped) or by a remote closing switch. Operation of the closing switch energizes the "X" relay, which in turn energizes the closing solenoid. This removes the prop, releasing the closing springs to close the breaker.

As the closing relay is energized, it energizes anti-pump relay "W". If the closing switch is maintained closed, the anti-pump relay will remain picked-up to prevent a second closing operation on the breaker in the event it is tripped open automatically. The closing impulse must be released and reapplied before a second closing operation can occur.

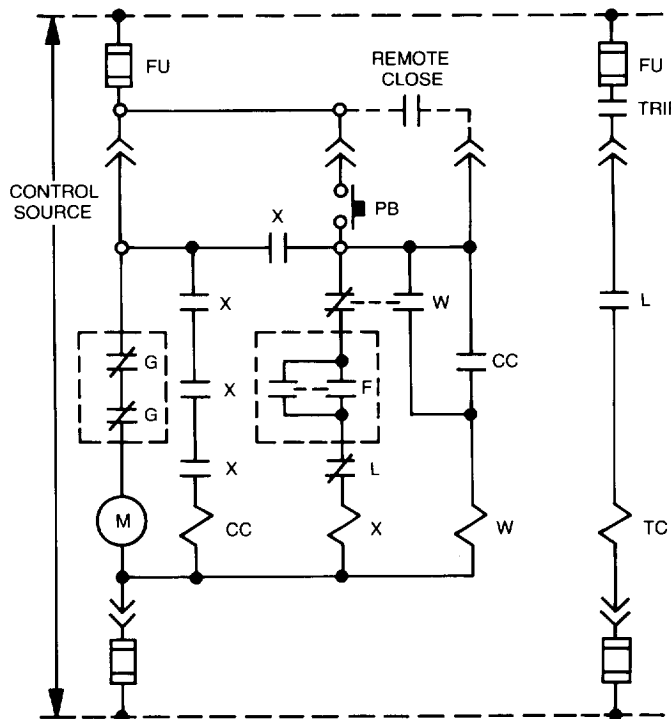

LEGEND

- CC — CLOSING SOLENOID
- F — CUTOFF SWITCH, CLOSED WHEN CLOSING SPRING IS FULLY CHARGED.
- G — CUTOFF SWITCH. OPEN WHEN CLOSING SPRING IS FULLY CHARGED.
- L — AUXILIARY SWITCH
- M — CHARGING MOTOR
- PB — CLOSE PUSHBUTTON ON BREAKER ESCUTCHEON, OPTIONAL.
- TC — SHUNT TRIP DEVICE
- W — ANTI-PUMP RELAY
- X — CONTROL RELAY

Fig. 5 Elementary diagram for electrically operated drawout breaker. Contact positions are shown with breaker open and closing springs discharged.

TRIPPING

In the closed position, the breaker's movable contacts are held in by a toggle linkage. The breaker is tripped open by displacing a mechanism latch which allows this toggle linkage to collapse. The trip latch is rigidly fastened to a horizontal trip shaft running from left to right through the breaker. In turn, the trip shaft carries paddles actuated by the manual trip button and the various other trip devices — overcurrent, reverse current, shunt trip, undervoltage, open fuse lockout. Viewing the breaker from the right, rotating the trip shaft counterclockwise trips the breaker; clockwise movement resets the mechanism latch.

In addition to tripping the breaker, some devices hold the breaker trip free, i.e., prevent the contacts from closing even though a closing impulse is applied to the mechanism. Such devices are the undervoltage, bell alarm and lockout, electric lockout, open fuse lockout, and the key operated locks.

These devices and the drawout mechanism interlocks must be in the reset position before the breaker can be closed.

FUSED BREAKERS (TYPE AKSU)

The AKSU-50 type breaker employs current limiting fuses mounted integrally with the breaker.

Included is an open fuse lockout device (OFLO) to prevent single-phasing in the event only one fuse blows.

The OFLO is a special trip device having three (3) shunt trip elements (one per phase), the coil of each being connected

across its corresponding fuse. The arc voltage generated by a blown fuse activates its OFLO shunt trip coil, thereby tripping the breaker and preventing single phase power from being supplied to the load. An indicator on the OFLO device signals which fuse is blown. The breaker cannot be closed until the blown fuse is acknowledged by resetting the OFLO. The fuse, of course, must be replaced.

MAINTENANCE

INSPECTION

Periodic inspection of the circuit breaker is recommended at least once a year. More frequent inspections are recommended where severe load conditions, dust, moisture or other unfavorable conditions exist, or if the vital nature of the load warrants it.

Always inspect the breaker after a short-circuit current has been interrupted.

At the time of inspection, the following checks should be made after the breaker has been deenergized:

1. Manually operate the breaker several times, checking for obstructions or excessive friction. Manual closing of an electrically operated breaker may be performed by the following two steps:

(1) Install maintenance crank (568B386G1) to the motor gear reducer shaft on the front right side of the breaker. Ratchet the maintenance crank up and down until the springs are fully charged as indicated by the distinct click as the prop is set and prevents any further charging of the closing springs. After the prop is set do not apply undue force to the maintenance handle.

(2) Depress the "Spring Discharge" lever located under the horizontal support on the front frame. The springs should discharge and if the latch is properly reset, the breaker will close.

2. Electrically operate the breaker several times to check performance of the electrical accessories.

3. Visually check the breaker for loose hardware on the breaker and the bottom of the compartment for any hardware that has fallen from the breaker.

4. Remove the arc quenchers and inspect the arc quenchers and contacts for breakage or excessive burning.

5. The performance of the solid-state current trip devices may be checked with a suitable test set. Check electromechanical devices for positive trip in accordance with the instructions in Maintenance Manual.

6. Check insulating parts for evidence of overheating and for cracks that indicate excessive thermal aging.

LUBRICATION

In general, the circuit breaker requires moderate lubrication. Bearing points and sliding surfaces should be lubricated at the regular inspection periods with a thin film of GE Lubricant D50HD38 (Mobil 28). Before lubricating, remove any hardened grease and dirt from latch and bearing surfaces with kerosene. ALL EXCESS LUBRICANT SHOULD BE REMOVED WITH A CLEAN CLOTH TO AVOID ACCUMULATION OF DIRT OR DUST.

On drawout breakers the contact surface of the disconnect studs should be cleaned and greased with GE Lubricant D50HD38.

REFERENCE PUBLICATIONS

These instructions provide information of a general nature on the installation and operation of Type AKS power circuit breakers. For more detailed information such as might be needed for overhauling, trouble shooting or replacing parts of the breaker, refer to the following instruction manuals applicable to the AKS-50 breaker.

| | |
|--|-------------|
| Maintenance Manual | GEK-64460 |
| Renewal Parts | GEF-4555 |
| ECS and SST Trip Devices | GEI-86156 |
| EC Trip Devices | GEI-86157 |
| ECS/SST Test Sets: | |
| Cat. TAK-TS1 | GEK-64454 |
| Cat. TAK-TS2 | GEK-73300-1 |
| High-Current Testing of AKS Breakers with ECS/SST | GEK-64455 |

TABLE 4. CURRENT RATINGS FOR AUXILIARY DEVICES

| Type Load or P.F. | Voltage | | Interrupting Rating (Amps) | |
|--|---------|---------|----------------------------|-------------------|
| | Nominal | Range | Auxiliary Switch | Bell Alarm Switch |
| Resistance | 48 dc | 38-56 | 25.00 | — |
| | 125 dc | 100-140 | 11.00 | 2.5 |
| | 250 dc | 200-280 | 2.00 | 0.9 |
| | 600 dc | 508-672 | 0.45 | 0.3 |
| Electro-Magnet | 48 dc | 38-56 | 15.00 | — |
| | 125 dc | 100-140 | 6.25 | 2.5 |
| | 250 dc | 200-280 | 1.75 | 0.9 |
| | 600 dc | 508-672 | 0.35 | 0.3 |
| 75-85% Lagging | 120 ac | 104-127 | 75.0 | 30.0 |
| | 240 ac | 208-254 | 50.0 | 15.0 |
| | 480 ac | 416-508 | 25.0 | 7.0 |
| | 600 ac | 520-635 | 12.0 | 5.0 |
| 30-35% Lagging | 120 ac | 104-127 | 50.0 | 30.0 |
| | 240 ac | 208-254 | 25.0 | 15.0 |
| | 480 ac | 416-508 | 12.0 | 7.0 |
| | 600 ac | 520-635 | 8.0 | 5.0 |
| Continuous Rating (Amps) | | | *20.0 | *10.0 |
| Closing Rating (Amps) 30-35% PF or resistive | | | 50.0 | 30.0 |

*On drawout breakers, limited to the 5 ampere continuous rating of #16 gage wire.

NOTES:

GEI-86160

NOTES:

NOTES:

DISTRIBUTION EQUIPMENT DIVISION • GENERAL ELECTRIC COMPANY
PLAINVILLE, CONNECTICUT 06062

GENERAL  **ELECTRIC**