

GEK-49804B



INSTRUCTIONS

INSTANTANEOUS OVERCURRENT RELAY

TYPES:

CFC11B
CFC11C

GE Protection and Control

CONTENTS

| | PAGE |
|---------------------------------|------|
| INTRODUCTION | 3 |
| APPLICATION | 3 |
| CHARACTERISTICS | 3 |
| RATINGS | 3 |
| CONTACTS | 5 |
| BURDENS | 5 |
| RECEIVING, HANDLING AND STORAGE | 5 |
| DESCRIPTION | 6 |
| INSTALLATION | 6 |
| LOCATION | 6 |
| MOUNTING | 6 |
| CONNECTIONS | 6 |
| ADJUSTMENTS | 7 |
| PICKUP | 7 |
| CLUTCH ADJUSTMENT | 7 |
| CONTACTS | 8 |
| INSPECTION | 8 |
| OPERATION | 8 |
| MAINTENANCE | 8 |
| CUP AND STATOR | 8 |
| BEARINGS | 9 |
| PERIODIC TESTING | 9 |
| CONTACT CLEANING | 9 |
| RENEWAL PARTS | 10 |

INSTANTANEOUS OVERCURRENT RELAYS

TYPE CFC11B AND CFC11C

INTRODUCTION

These relays consist of one induction cup overcurrent unit mounted in a one-unit, single-end, case.

This unit is an induction-cylinder device for alternating-current circuits. The principle by which torque is developed in these induction cylinder relays is the same as that employed in an induction-disk relay with a watt-hour meter element, though in arrangement of parts they are more like split-phase induction motors.

The stator has eight laminated magnetic poles projecting inward and arranged symmetrically around a central magnetic core. In the annular air gap between the poles and central core is the cylindrical part of the cup-like aluminum rotor, which turns freely in the air gap. The central core is fixed to the stator frame; the rotor alone turns.

All eight poles have current windings and are all connected in series. The four corner coils have an additional winding, which is many turns of fine wire. A capacitor is connected across these four coils in series to provide a phase shift in the flux so as to produce torque.

This construction provides higher torque and lower rotor inertia than the induction-disk construction, making these relays faster and more sensitive.

APPLICATION

The type CFC relays are employed primarily for instantaneous overcurrent protection of feeders and transmission lines where no overreach and low burden is desired.

CHARACTERISTICS

The CFC11B and 11C relays are instantaneous overcurrent units with one circuit closing contact.

The time current characteristics of the type CFC relays are shown in Fig. 8.

RATINGS

The current-closing rating of the contacts is 30 amperes for voltages not exceeding 250 volts.

The current-carrying rating is limited by the two forms of seal in units available. The choice between them depends on the current taken by the tripping circuit.

The rating and impedance of the seal-in unit for the 0.2 and 2 ampere taps are given in Table I. The tap setting used will depend on the current drawn by the trip coil.

TABLE I

SEAL-IN UNIT RATINGS

| | <u>Dual Rated</u> | | | |
|--|--------------------|------------|--------------------|------------|
| | <u>0.2/2.0 Amp</u> | | <u>0.6/2.0 Amp</u> | |
| | <u>0.2</u> | <u>2.0</u> | <u>0.6</u> | <u>2.0</u> |
| Carry 30 amps for (sec.) | 0.05 | 2.2 | 0.5 | 3.5 |
| Carry 10 amps for (sec.) | 0.45 | 2.0 | 5.0 | 30 |
| Carry continuously (amp) | 0.37 | 2.3 | 1.2 | 2.6 |
| Minimum operating (amp) | 0.2 | 2.0 | 0.6 | 2.0 |
| Minimum drop-out (amp) | 0.05 | 0.5 | 0.15 | 0.5 |
| DC resistance (ohms) | 8.3 | 0.24 | 0.78 | 0.18 |
| 60 Hz impedance (ohms) | 50 | 0.65 | 6.2 | 0.65 |
| 50 Hz impedance (ohms) | 42 | 0.54 | 5.1 | 0.54 |
| Interrupting rating (amps) DC resistive | 2.5 amp @ 125 VDC | | | |

These instructions do not purport to cover all details or variations in equipment nor to provide for every possible contingency to be met in connection with installation, operation or maintenance. Should further information be desired or should particular problems arise which are not covered sufficiently for the purchaser's purposes, the matter should be referred to the General Electric Company.

To the extent required the products described herein meet applicable ANSI, IEEE and NEMA standards; but no such assurance is given with respect to local codes and ordinances because they vary greatly.

The 0.2 ampere tap is for use with trip coils which operate on currents ranging form 0.2 up to 2.0 ampere at the minimum control voltage. If this tap is used with trip coils requiring more than 2 amperes, there is a possibility that the resistance of 7 ohms will reduce the current to so low a value that the breaker will not be tripped.

The 2 ampere tap should be used with trip coils that take two amperes or more at minimum control voltage, provided the current does not exceed 30 amperes at the maximum control voltage. If the tripping current exceeds 30 amperes, the connections should be arranged so that the induction unit contacts will operate an auxiliary relay which in turn energizes the trip coil or coils. On such an application, it may be necessary to connect a loading resistor in parallel with the auxiliary relay coil to allow enough current to operate the target seal-in unit.

CONTACTS

The current-closing rating of the induction unit contacts is 30 amperes for voltages not exceeding 250 volts. Their current-carrying rating is limited by the tap rating of the seal-in unit.

TABLE II

**RATINGS OF INSTANTANEOUS OVERCURRENT
UNIT OPERATING COILS**

| Relay | Pickup Range Amps) | Continuous Rating (Amps) | One Second Rating (Amps) |
|--------|-----------------------|-----------------------------|-----------------------------|
| CFC11C | .5-2 | 2.5 | 90 |
| CFC11C | 1-4 | 4.0 | 150 |
| CFC11B | 2-8 | 7.5 | 150 |
| CFC11B | 4-16 | 7.5 | 150 |

BURDENS

Current coil burdens at 5 amperes and rated frequency

| Relay | Current Range in Amps | Freq. | R | XL |
|---------|--------------------------|-------|------|------|
| CFC11B1 | 4-16 | 60 | 0.17 | 0.15 |
| CFC11B2 | 2-8 | 60 | 0.36 | 0.45 |
| CFC11C1 | 1-4 | 60 | 0.21 | 0.3 |
| CFC11C2 | .5-2 | 60 | 0.84 | 1.20 |

RECEIVING, HANDLING AND STORAGE

These relays, when not included as apart of a control panel, will be shipped in cartons designed to protect them against damage. Immediately upon receipt of the relay an examination should be made for any damage sustained during shipment. If injury or damage resulting from rough handling is evident, a claim should be filed at once with the transportation company and the nearest Sales Office of the General Electric Company notified promptly.

Reasonable care should be exercised in unpacking the relay in order that none of the parts are injured or the adjustments disturbed.

If the relays are not to be installed immediately, they should be stored in their original cartons in a place that is free from moisture, dust, and metallic chips. Foreign matter collected on the outside of the case may find its way inside when the cover is removed and cause trouble in the operation of the relay.

DESCRIPTION

The case is suitable for either surface or semi-flush panel mounting and an assortment of hardware is provided for either mounting. The cover attaches to the case and also carries the reset mechanism when one is required. Each cover screw has provision for a sealing wire.

The case has studs or screw connections at both ends or at the bottom only for the external connections. The electrical connections between the relay units and the case studs are made through spring-backed contact fingers mounted in stationary molded inner and outer blocks between which nests a removable connecting plug which completes the circuits. The outer blocks, attached to the case, have the studs for the external connections, and the inner blocks have the terminals for the internal connections.

The relay mechanism is mounted in a steel framework called the cradle and is a complete unit with all leads being terminated at the inner block. This cradle is held firmly in the case with a latch at the top and the bottom and by a guide pin at the back of the case. The cases and cradles are so constructed that the relay cannot be inserted in the case upside down. The connecting plug, besides making the electrical connections between the respective blocks of the cradle and case, also locks the latch in place. The cover, which is fastened to the case by thumbscrews, holds the connecting plug in place.

To draw out the relay unit the cover is first removed, and the plug drawn out. Shorting bars are provided in the case to short the current transformer circuits. The latches are then released, and the relay unit can be easily drawn out. To replace the relay unit, the reverse order is followed.

A separate testing plug can be inserted in place of the connecting plug to test the relay in place on the panel either from its own source of current and voltage, or from other sources. Or, the relay unit can be drawn out and replaced by another which has been tested in the laboratory.

INSTALLATION

LOCATION

The location should be clean and dry, free from dust and excessive vibration, and well lighted to facilitate inspection and testing.

MOUNTING

The relay should be mounted on a vertical surface. The outline and panel diagram is shown in fig. 9.

CONNECTIONS

Internal connection diagrams for the various relay types are shown in fig. 6. Typical wiring diagrams are given in Fig. 3.

One of the mounting studs or screws should be permanently grounded by a conductor not less than No. 12 B & S gage copper wire or its equivalent.

ADJUSTMENTS

Pickup

1. The pickup of the instantaneous overcurrent unit can be adjusted over a four-to-one range, as indicated in Table II, by varying the tension of the spiral control spring. The outside end of this spring is fastened to a post on the adjusting ring above the moving contact, and the ring is in turn clamped in position by a hexagonal-head locking screw. If this screw is loosened, the ring can be slipped to vary the spring tension.
2. The pickup is set at the factory at the minimum point of the pickup current range.
3. Connect relay per Test Connections Fig. 7.
4. Unit should close its contacts within plus or minus 5 percent of the minimum pickup current range.
5. Apply the maximum current pickup of the unit; it should not be necessary to wind the control spring more than one turn (360 degrees) to just balance the restraining and operating torques.
6. Reset the control spring for minimum pickup. Re-tighten the control clamping screw and recheck pickup.
7. The clutch should not slip at six times pickup current. It may, however, slip at eight times pickup current.

Clutch Adjustment

Clutch adjustment is made with connections as shown in Fig. 7, with the adjustable resistor capable of controlling the current in the current coils between 5 and 25 amperes. A screw on the side of the moving contact arm controls the clutch pressure. Using rated frequency the clutch should be set to slip at the proper current as shown in the table below:

| Pick-Up Amps Rating | Amps for Clutch to slip |
|------------------------|----------------------------|
| .5-2 | 12 |
| 1-4 | 24 |
| 2-8 | 48 |
| 4-16 | 96 |

Contacts

The contacts (Fig. 2) are specially constructed to suppress bouncing. The stationary contact (G) is mounted on a flat spiral spring (F) backed by a thin diaphragm (C). These are both mounted in a slightly inclined tube (A). A stainless steel ball (B) is placed in the tube before the diaphragm is assembled. When the moving contact hits the stationary contact, the energy of the former is imparted to the latter and thence to the ball, which is free to roll up the inclined tube. Thus, the moving contact comes to rest with substantially no rebound or vibration. To change the stationary contact mounting spring, remove the contact barrel and sleeve as a complete unit after loosening the screw at the front of the contact block. Unscrew the cap (E). The contact and its fault spiral mounting spring may then be removed.

The contact gap may be adjusted by loosening slightly the same screw at the front of the contact block. The screw should be loose enough only to allow the contact barrel to rotate in its sleeve.

The stop screw fastened with a locknut should hold the moving contact arm in a neutral position, i.e., with it pointing directly forward. Then bring the stationary contact up until it just touches the moving contact by rotating the contact barrel. Next, back it away 2/3 turn to obtain approximately 0.020 inch contact gap. Last, tighten the screw which secures the barrel.

The moving contact may be removed by loosening the screw which secures it to the contact arm and sliding it from under the screw head.

INSPECTION

At the time of installation, the relay should be inspected for tarnished contacts, loose screws, or other imperfections. If any trouble is found, it should be corrected in the manner described under MAINTENANCE.

OPERATION

Before the relay is put into service it should be given a partial check to determine that factory adjustments have not been disturbed.

MAINTENANCE

The relays are adjusted at the factory and it is advisable not to disturb the adjustments. If for any reason, they have been disturbed, the following points should be observed in restoring them:

CUP AND STATOR

Should it be necessary to remove the cup-type rotor from the directional unit, the following procedure should be followed:

All leads to the unit should first be disconnected and tagged for identification in reconnecting. The unit can then be removed from the cradle with its mounting plate still attached.

The upper of the three flat-head screws holding the unit to the plate should now be removed. On some models, it may be necessary to remove a resistor or capacitor to expose this screw. The four corner screws clamping the unit together, should next be removed, and the entire top structure lifted off. This gives access to the cup assembly and exposes the stator assembly, which should be protected to keep it free from dust and metallic particles until the unit is reassembled.

To remove the shaft and rotor from the contact head assembly, the spring clip at the top of the shaft must be pulled out and the clutch adjusting screw taken out of the side of the molded contact arm. The shaft and cup can now be pulled out of the molding. The rotor must be handled very carefully while it is out of the unit.

BEARINGS

The lower jewel bearing should be screwed all the way in until its head engages the end of the threaded core support. The upper bearing should be adjusted to allow 0.015 to 0.020 inch end play to the shaft.

To check the clearance between the iron core and inside of the rotor cup, press down on the contact arm near the shaft, thus depressing the spring-mounted jewel until the cup strikes the iron. The shaft should move about 1/16 inch.

The lower jewel may be tested for cracks by exploring its surface with the point of a fine needle. If it is necessary to replace the jewel a new pivot should be screwed into the end of the shaft at the same time.

PERIODIC TESTING

An operation test and inspection of the relay at least once every six months are recommended. Test connections are shown in Fig. 7.

CONTACT CLEANING

For cleaning fine silver contacts, a flexible burnishing tool should be used. This consists of a flexible strip of metal with an etched-roughened surface, resembling in effect a superfine file. The polishing action is so delicate that no scratches are left, yet corroded material will be removed rapidly and thoroughly. The flexibility of the tool insures the cleaning of the actual points of contact. Sometimes an ordinary file cannot reach the actual points of contact because of some obstruction from some other part of the relay.

GEK-49804

Fine silver contacts should not be cleaned with knives, files, or abrasive paper or cloth. Knives or files may leave scratches which increase arcing and deterioration of the contacts. Abrasive paper or cloth may leave minute particles of insulating abrasive material in the contacts and thus prevent closing.

The burnishing tool described is included in the standard relay tool kit obtainable from the factory.

RENEWAL PARTS

It is recommended that sufficient quantities of renewal parts be carried in stock to enable the prompt replacement of any that are worn, broken, or damaged.

When ordering renewal parts, address the nearest Sales Office of the General Electric Company, specify quantity required, name of part wanted, and give complete nameplate data, including serial number. If possible, give the General Electric Company requisition number on which the relay was furnished.

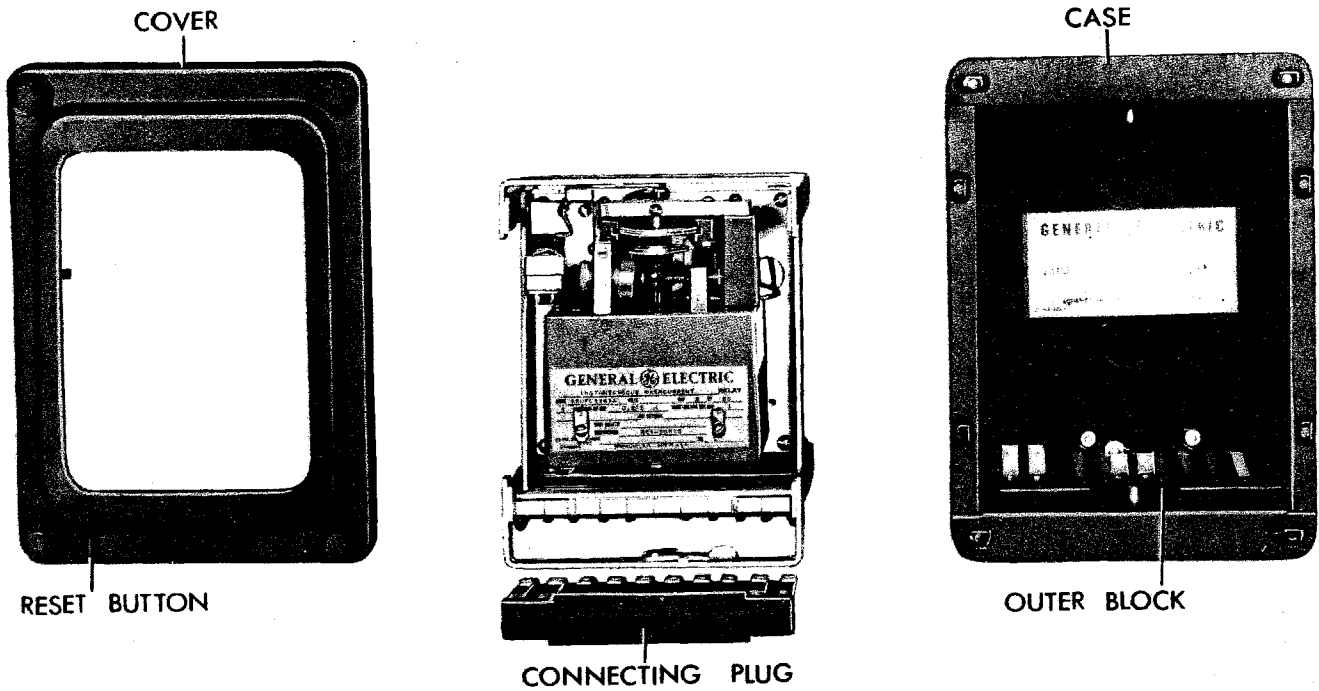
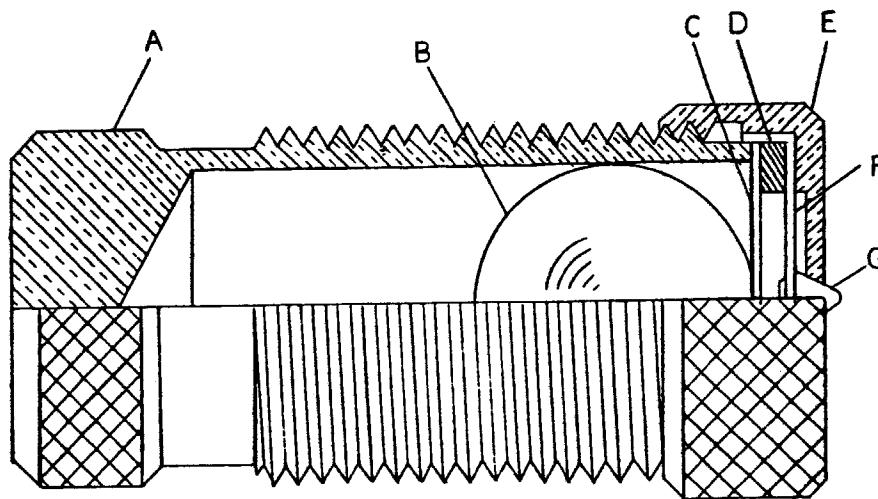

Fig. 1 (8008880) Type CFC11B and 11C Relays Disassembled



- | | |
|-------------------------|-----------------------|
| A- INCLINED TUBE | D- SPACER |
| B- STAINLESS STEEL BALL | E- CAP |
| C- DIAPHRAM | F- FLAT SPIRAL SPRING |
| G- CONTACT | |

Fig. 2 (K-6077069-4) Contact Assembly for Type CFC11B and 11C Relays

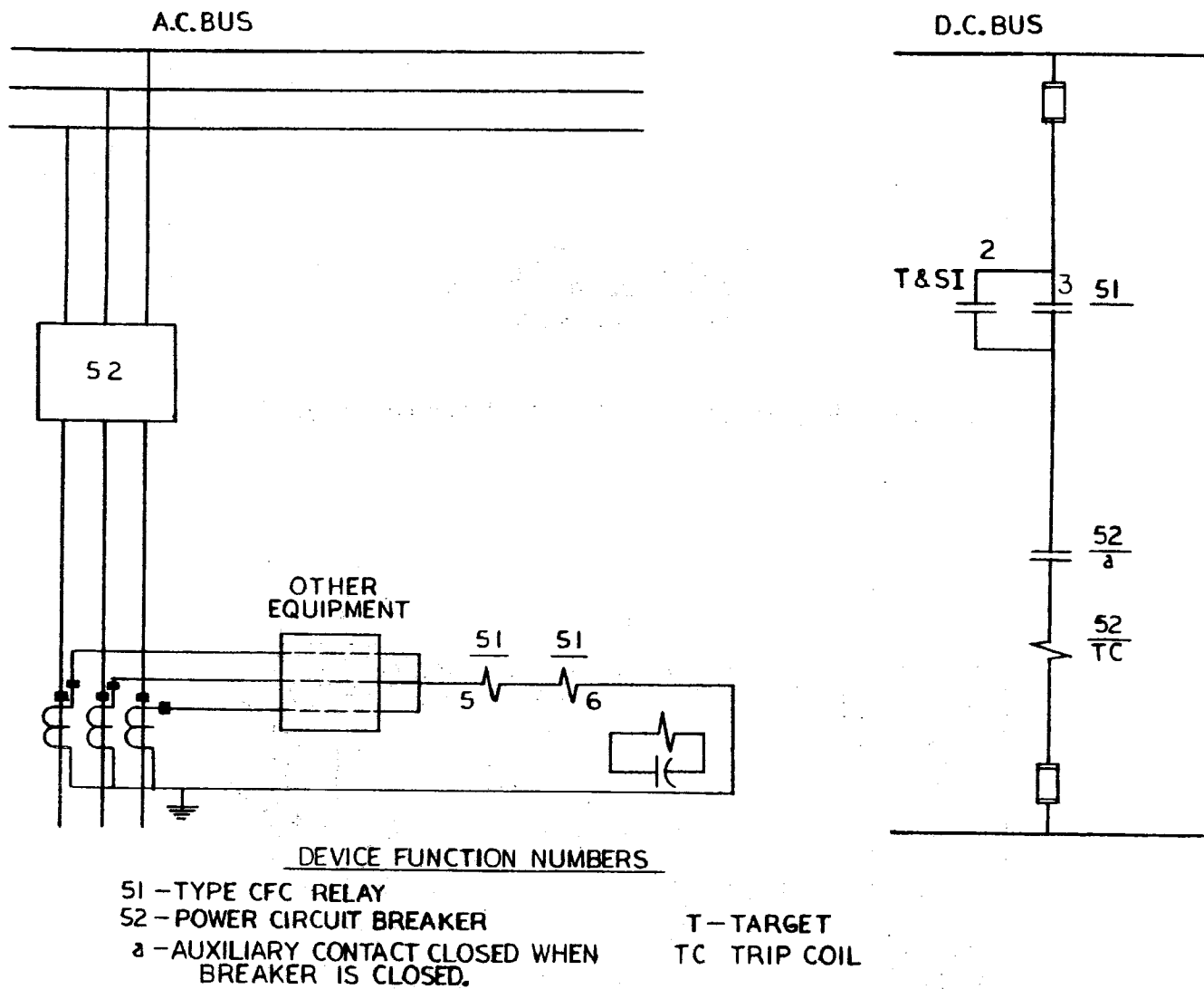

Fig. 3 (0208A8534-0) External Connection of CFC11B and 11C Relays for Ground Fault Protection

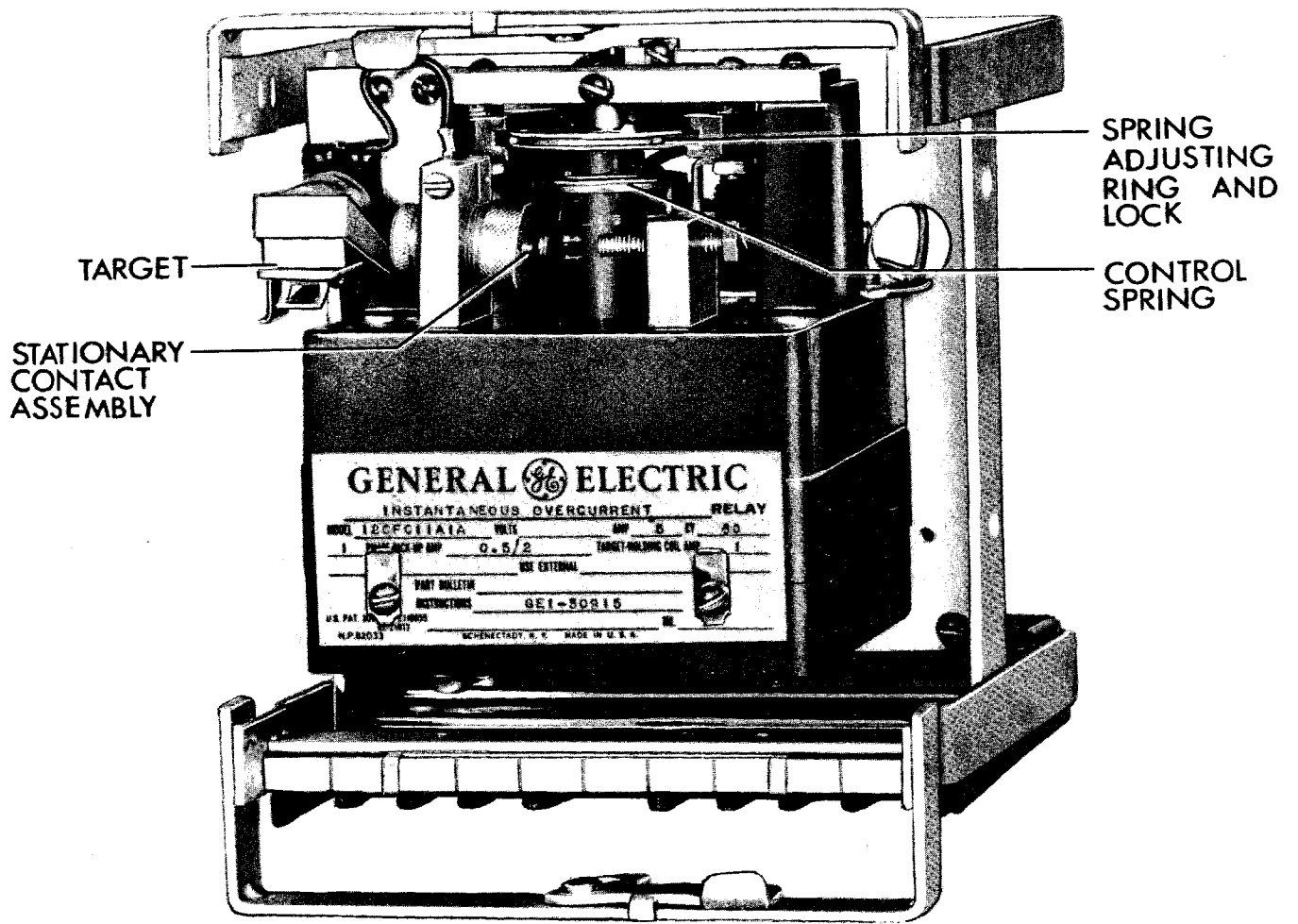

Fig. 4 (8008879) Type CFC11B and CFC11C Withdrawn from Case, Front view

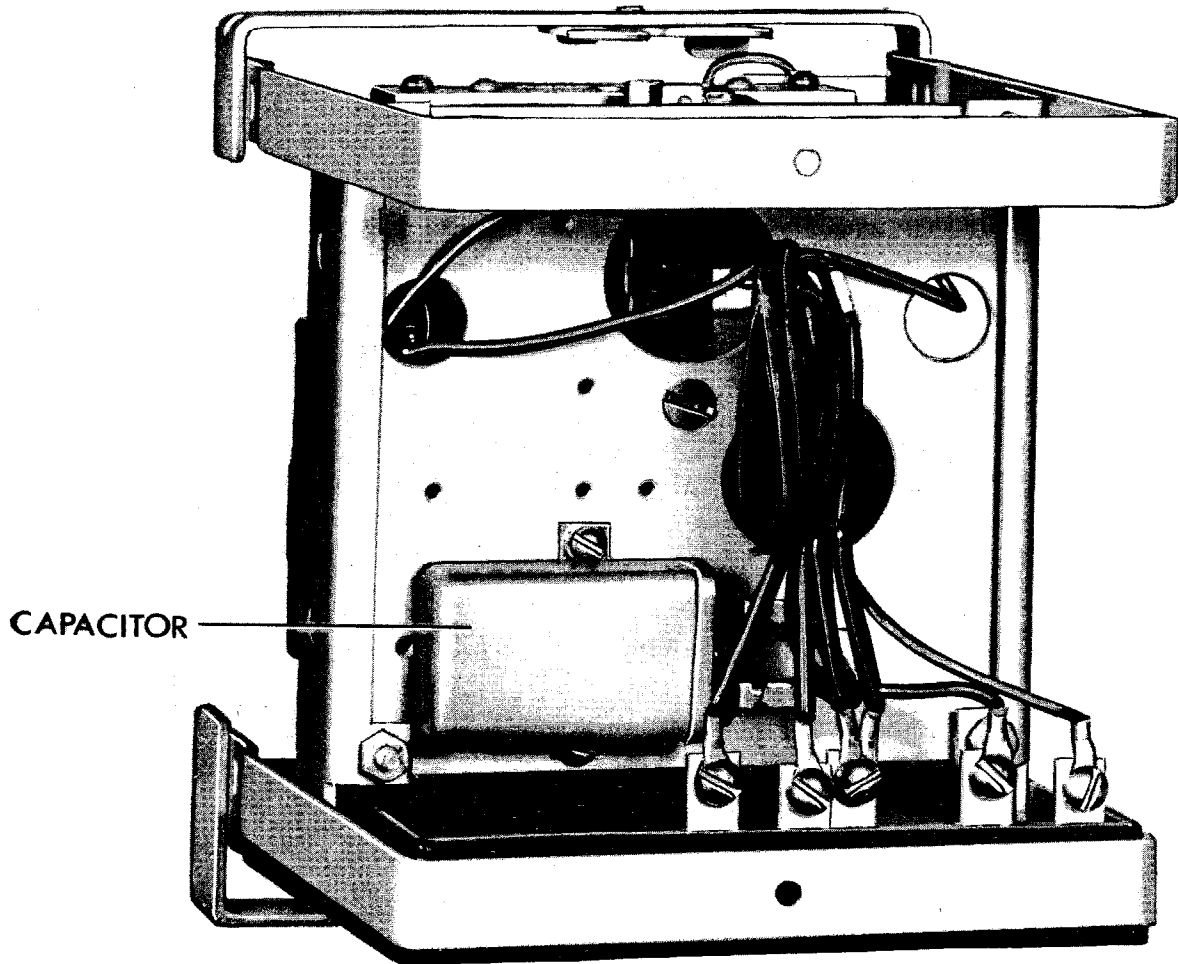

Fig. 5 (8008881) Type CFC11B and 11C Withdrawn from Case, Back View

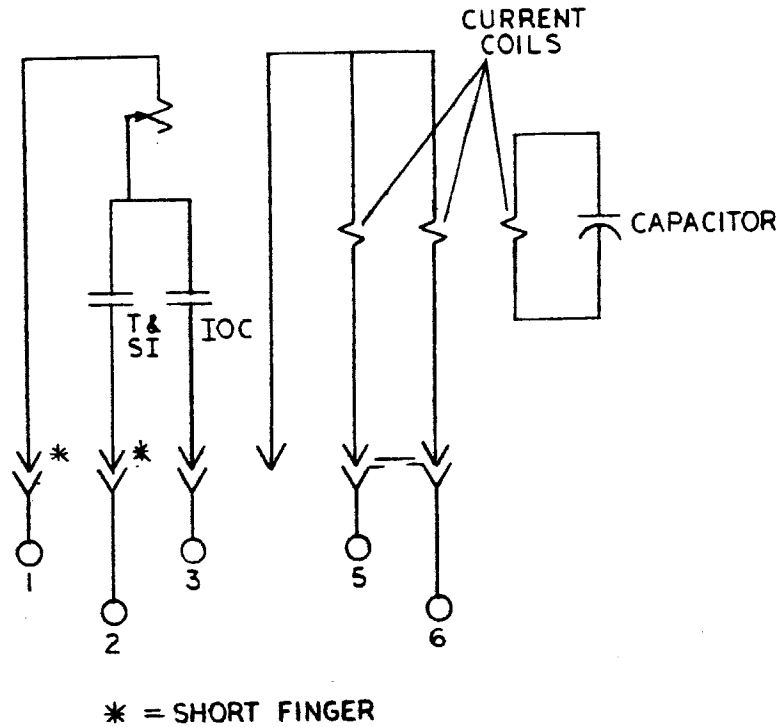
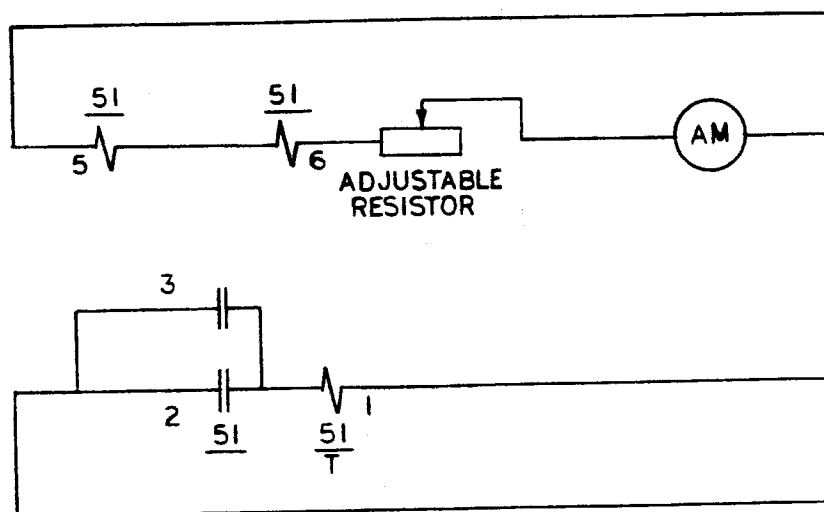

Fig. 6 (0269A3085-0) Internal Connections for Type CFC11B and 11C Relays



DEVICE FUNCTION NUMBERS
 51 - TYPE CFC OVERCURRENT RELAY
 T - TARGET COIL
 AM - AMMETER

Fig. 7 (0208A8535-0) Connections for Single Phase Test of CFC11B and 11C Relays

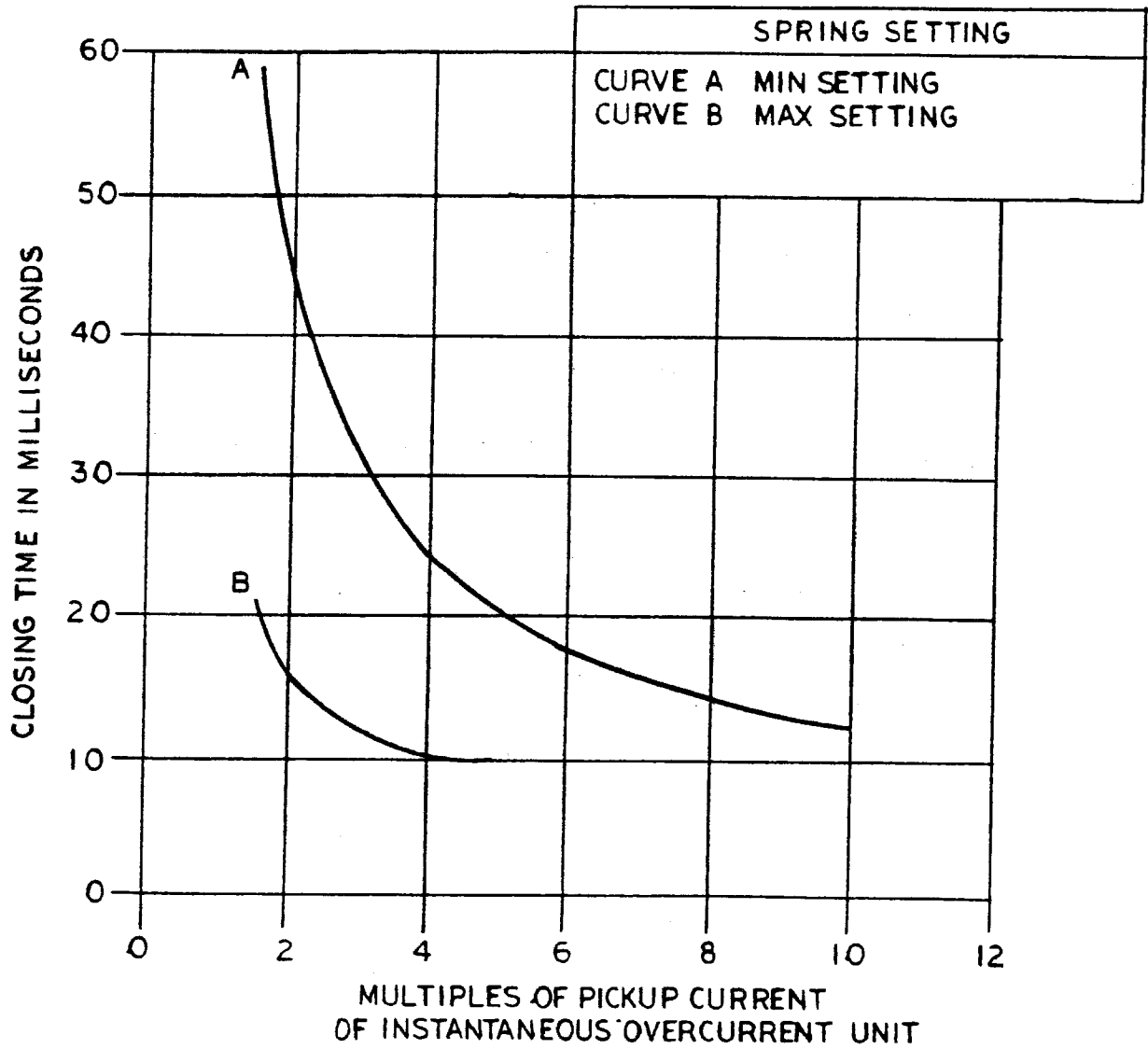

Fig. 8 (0208A8533-0) Time-current Characteristics of the Type CFC11B and 11C Relays

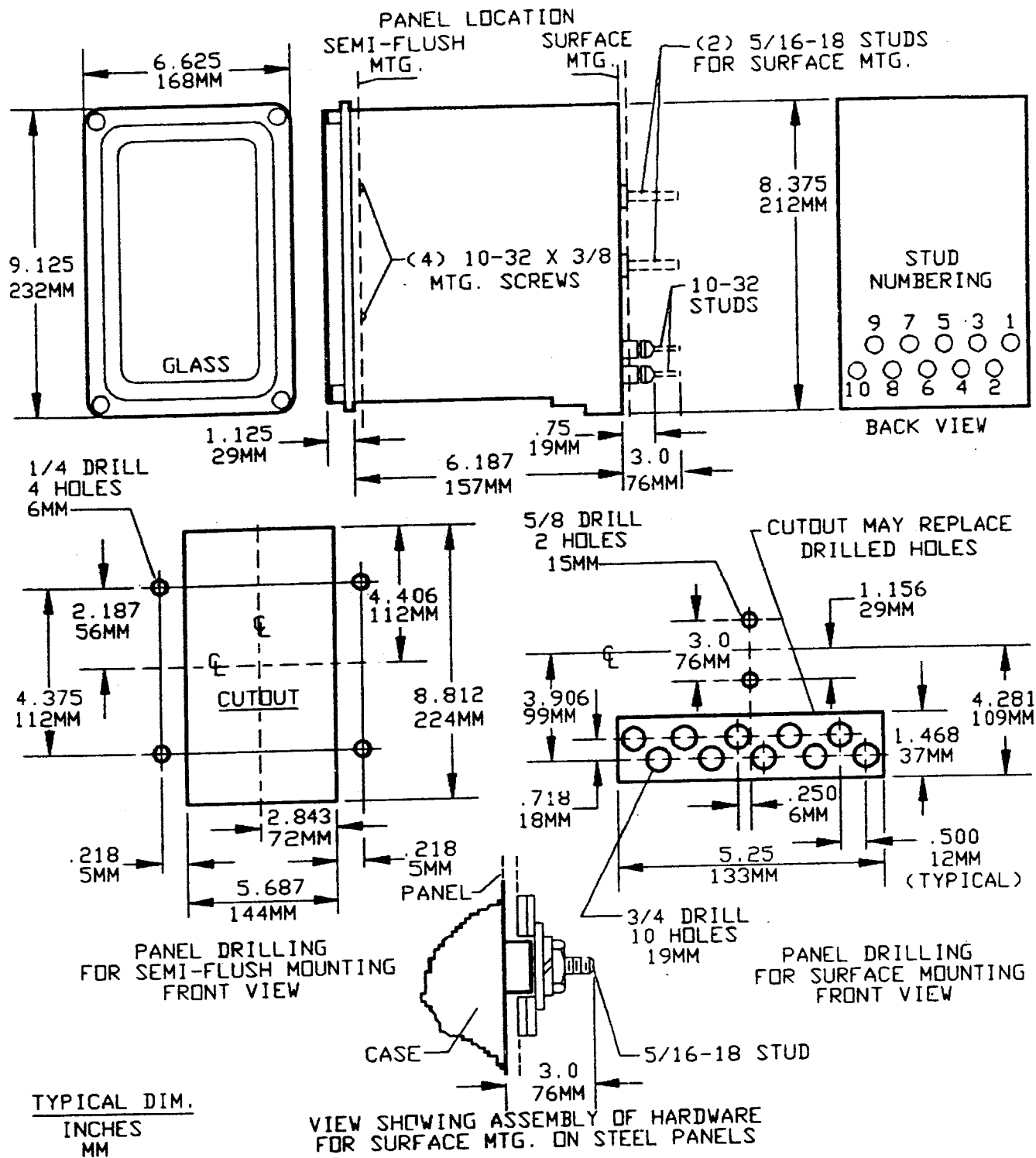
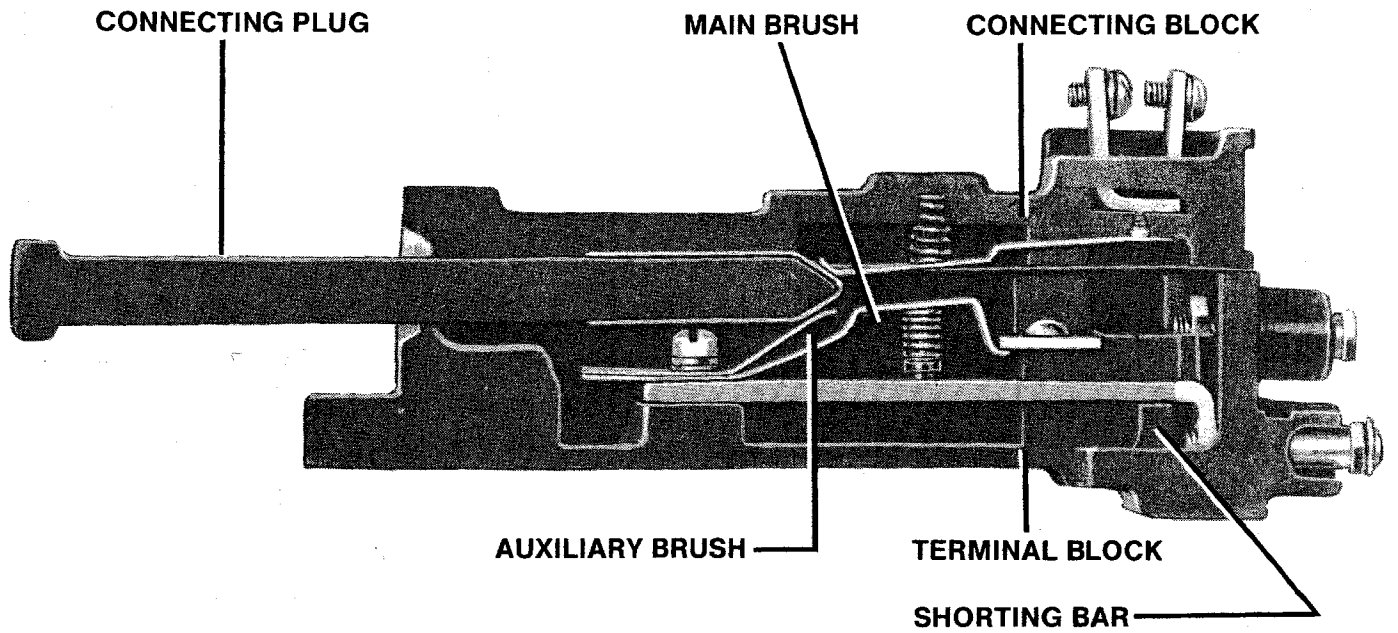

Fig. 9 (6209271-8) Outline and Panel Drilling for Type CFC11B and 11C Relays



NOTE: AFTER ENGAGING AUXILIARY BRUSH CONNECTING PLUG TRAVELS ¼ INCH BEFORE ENGAGING THE MAIN BRUSH ON THE TERMINAL BLOCK.

Fig. 10 (8025039) Cross Section of Drawout Case Showing Connection Assembly



GE Power Management

215 Anderson Avenue
Markham, Ontario
Canada L6E 1B3
Tel: (905) 294-6222
Fax: (905) 201-2098
www.GEindustrial.com/pm