

INSTRUCTIONS

GEI-30916E
SUPERSEDES GEI-30916D

FREQUENCY RELAYS

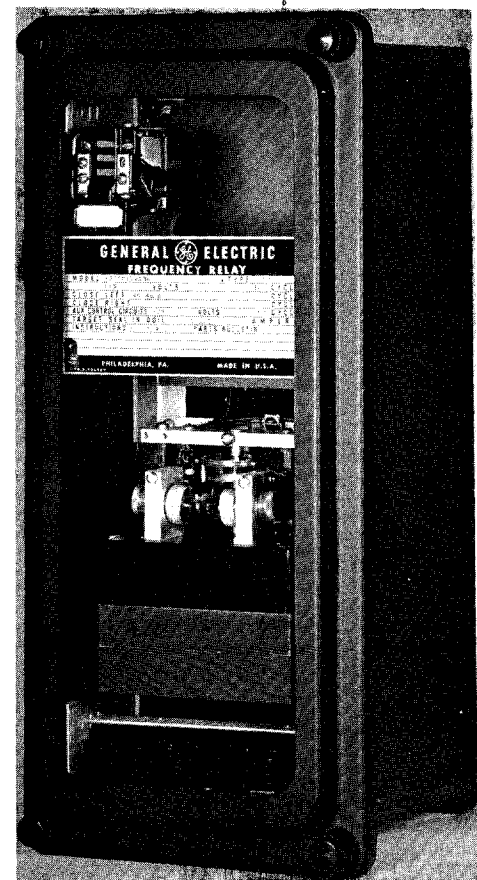

Types

CFF12A23 and Up

CFF12C

CFF12B31 and Up

CFF12D

LOW VOLTAGE SWITCHGEAR DEPARTMENT

GENERAL  ELECTRIC

FREQUENCY RELAYS

TYPE CFF

INTRODUCTION

The CFF12 relays covered by this Instruction Book include overfrequency and underfrequency devices. All of these relays are built around high speed cup type units but they include a 6 cycle time delay auxiliary unit to provide security against misoperation due to mechanical shock and switching of potential to the relays. They all have both normally open and normally closed contacts. In the case of the underfrequency relays, the normally open contacts will close on underfrequency. In the case of the overfrequency relays the normally open contacts will close on overfrequency. The range of adjustments are given in the section on characteristics. All of these relays are built in M1 cases and the differences between them are noted in the following table.

TABLE I

Relay Type	Characteristic	Auxiliary Circuit	Target
CFF12A	Underfrequency	d-c	Series Target Seal-In
CFF12B	Overfrequency	d-c	Series Target Seal-In
CFF12C	Underfrequency	a-c	Shunt Target
CFF12D	Overfrequency	a-c	Shunt Target

APPLICATION

The CFF12 relays find application where high speed detection of over or underfrequency is required. Specifically, the underfrequency relays are applied in underfrequency load shedding schemes to protect a system from total collapse in the event that a system disturbance results in loss of generating capacity to the point where load exceeds generation. Another application of the underfrequency relays is at industrial plants where it is necessary to trip the incoming breaker at an industrial plant when the power company supply is tripped off. This will prevent damage to motors in the plant that could otherwise be incurred if the plant breaker were closed when the power company automatically reclosed the supply to the plant.

In general, the CFF12A and CFF12B relays should be applied where a d-c source of potential is available to operate the 6 cycle auxiliary unit. The CFF12C and CFF12D relays would be applied where a d-c source is not available. The CFF12C and

CFF12D relays have no seal-in units so they should not be used in applications where there is a possibility of the relay contacts being required to interrupt trip coil currents.

See Figs. 8 and 9 for typical external connections for the CFF relays.

OPERATING CHARACTERISTICS

A typical time-frequency curve is shown in Fig. 1. This curve includes the time delay of the internal auxiliary relay when energized at rated auxiliary circuit voltage. As control voltage decreases, the time delay in closing the trip circuit increases. The minimum pick-up voltage of the auxiliary relays is 80 per cent of rated auxiliary voltage, and below this value tripping will not be initiated.

Fig. 2 shows a typical voltage-frequency curve. This curve is applicable to Types CFF12C and CFF12D only when the voltage is above the minimum pickup of the auxiliary relays. (See DESCRIPTION and Fig. 7).

The frequency at which the contacts close is adjusted by means of the rheostat mounted in the relay case.

RATINGS

INDUCTION CUP UNIT

The Type CFF12 overfrequency and underfrequency relays are continuously adjustable over a range above or below rated frequency, respectively. Adjustment is made by means of a rheostat to cause the left contacts to close and the auxiliary circuit to operate. The following table lists the range over which commonly rated relays may be calibrated.

TABLE II

Frequency Relays - Type CFF			
Relay Type	Rated Frequency	Min. Closing Frequency	Max. Closing Frequency
CFF12A and CFF12C	25 50 60	23 46 54	24.5 49.5 59.5
CFF12B and CFF12D	25 50 60	25.5 50.5 60.5	27 53 63

These instructions do not purport to cover all details or variations in equipment nor to provide for every possible contingency to be met in connection with installation, operation or maintenance. Should further information be desired or should particular problems arise which are not covered sufficiently for the purchaser's purposes, the matter should be referred to the General Electric Company.

Cover (8034733)

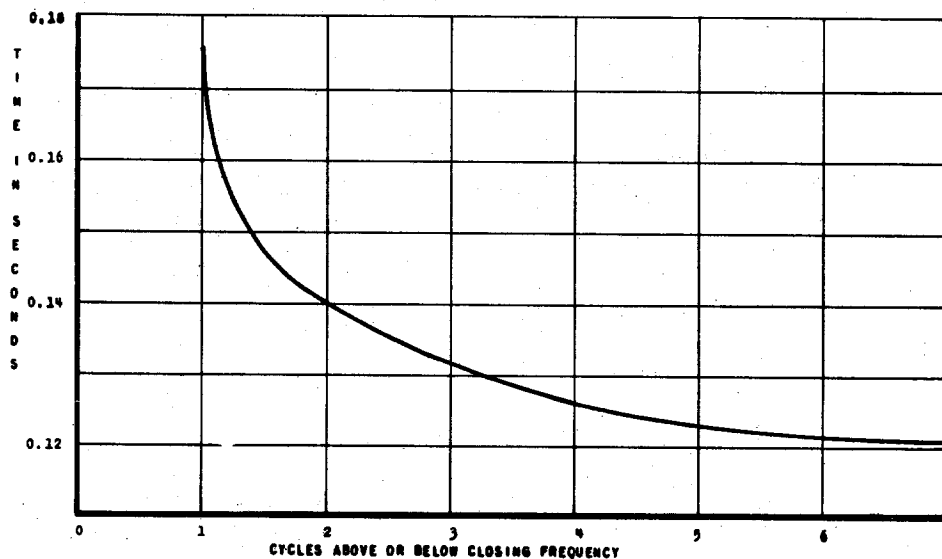

Fig. 1 (K-6507943-0) Time-Frequency Curve For Type CFF Relays. Time Includes Six Cycle Time Delay At 115 Volts With 1/16 Inch Cup Unit Contact Gap

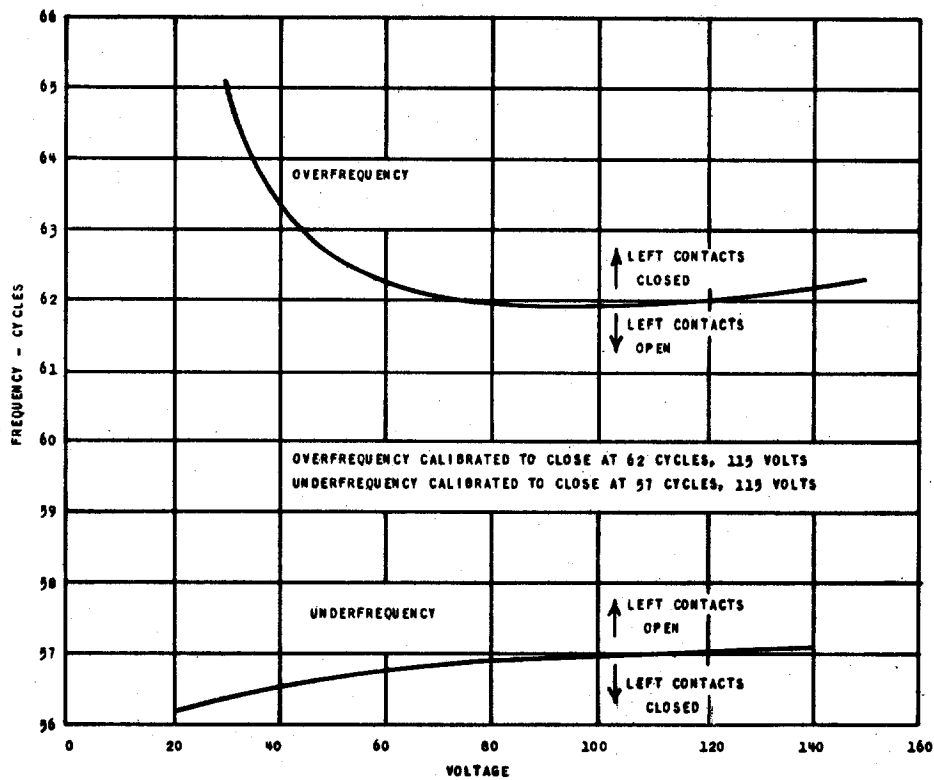

Fig. 2 (K-6556561-0) Voltage-Frequency Curve For Type CFF Relays

CONTACTS

The current closing rating of the trip circuit contacts is 30 amperes for voltages not exceeding 250 volts. These contacts must not be permitted to open while trip current is flowing. *The interrupting capacity, if used for other than direct tripping duty, is 0.25 ampere at 250 volts, or 0.5 ampere at 125 volts in an inductive d-c circuit.

TARGET-SEAL-IN

The target-seal-in coil of Types CFF12A and CFF12B has two current ratings, either of which can be selected by tap setting. The 2 ampere tap inserts a coil of 0.13 ohm resistance into the trip circuit. It should be used with trip coils which take 2 amperes or more at the minimum control voltage, providing the tripping current does not exceed 30 amperes at the maximum control voltage. Where more than 30 amperes will be required, an auxiliary relay should be used with connections such that tripping current does not flow through the target-seal-in coil.

The 0.2 ampere tap inserts a coil of 7 ohms resistance into the trip circuit, and should be used with trip coils operating in the range 0.2 to 2.0 amperes at the minimum control voltage. Care should be exercised in using this tap with trip coils which require higher currents because the 7 ohms will limit the tripping current and the breaker may not be tripped.

The following table gives the maximum ratings:

TABLE III

Trip Circuit Ratings - CFF12A & CFF12B		
Condition	Amperes a-c or d-c	
	2.0 Amp Tap (0.13 Ohm d.c.)	0.2 Amp Tap (7 Ohms d.c.)
Tripping Duty	30	5
Carry Continuously	3	0.3

The trip circuit rating of Types CFF12C and CFF12D is 30 amperes, a-c or d-c.

BURDENS

The adjustment of left contact closing frequency of Type CFF relays affects the burden imposed on the potential transformer. The following table lists the 60 cycle burdens of the two potential circuits for two relay calibrations. Burdens for Types CFF12C and CFF12D include the load imposed by the a-c operated auxiliary circuits during the period when the left contacts of the cup unit are closed. After the left contacts open and before the right contacts close, the current drawn by the auxiliaries is reduced. After the right contacts close, and until the left contacts again close, the burden is the same as for Types CFF12A and CFF12B.

TABLE IV

60 Cycle Burdens				
Relay Type	Voltage Rating	Calibration (Cycles)	Terminals 5-6	
			Watts	Volt Amps
CFF12A	115	56	4.4	5.1
	and 230	59.5	5.0	6.6
CFF12B	115	60.5	5.1	6.8
	and 230	63	5.25	7.5
CFF12C	115	56	9.9	10.6
	115	59.5	10.5	11.9
	230	56	22.6	23.4
CFF12D	230	59.5	23.2	24.5
	115	60.5	10.6	12.1
	115	63	10.7	12.7
	230	60.5	23.3	24.7
All Types, Voltage Ratings, and Calibrations	230	63	23.5	25.1
				Terminals 7-8
			4.8	5.9

RECEIVING, HANDLING AND STORAGE

These relays, when not included as a part of a control panel, will be shipped in cartons designed to protect them against damage. Immediately upon receipt of a relay, examine it for any damage sustained in transit. If injury or damage resulting from rough handling is evident, file a damage claim at once with the transportation company and promptly notify the nearest General Electric Apparatus Sales Office.

Reasonable care should be exercised in unpacking the relay in order that none of the parts are injured or the adjustments disturbed.

If the relays are not to be installed immediately, they should be stored in their original cartons in a place that is free from moisture, dust and metallic chips. Foreign matter collected on the outside of the case may find its way inside when the cover is removed and cause trouble in the operation of the relay.

DESCRIPTION

RELAY TYPES

The Type CFF12A (see Fig. 3) is an induction cup underfrequency relay. One normally open contact and one normally closed contact are available for external circuit connections. The two contact circuits are electrically separate and are controlled by a telephone relay unit. The telephone relay unit is operated when the left contacts of the cup unit close, and it remains picked-up until the right contacts close. The left contacts of the cup unit close at a frequency below rated value by a

GEI-30916 Frequency Relays Type CFF

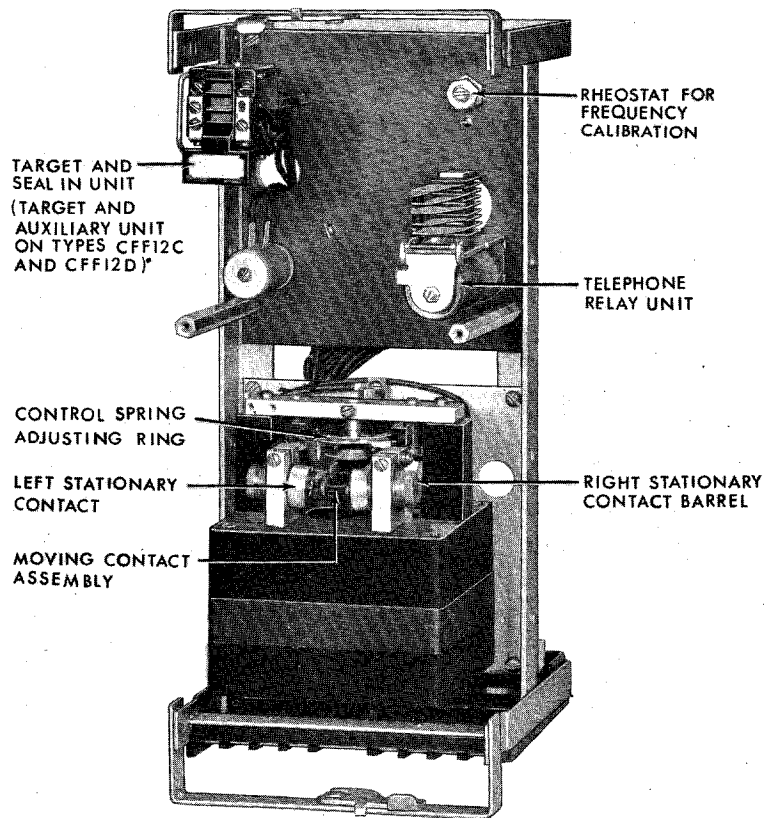

*Fig. 3 (8034731) Type CFF12A Relay Removed From The Case (Front View)

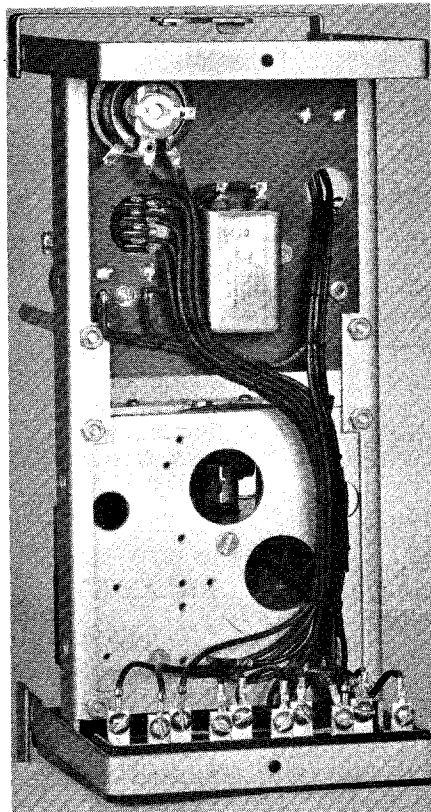

*Fig. 4 (8034732) Type CFF12A Relay Removed From The Case (Rear View)

predetermined amount. The right contacts are closed when the relay is de-energized, and also when energized at or above rated frequency. A target and seal-in unit operates in conjunction with the normally open contact to provide an indication of relay operation and to maintain trip circuit continuity through the relay as long as tripping current is flowing.

The Type CFF12B is an overfrequency relay. It is similar in all respects to the Type CFF12A except that the cup unit functions to close its left contacts at a frequency above rated value by a predetermined amount. The right contacts are closed when the relay is de-energized, and also when energized at or below rated frequency.

The Type CFF12C is an induction-cup under-frequency relay. Its operation is similar to the Type CFF12A except that the target is exposed not as a result of tripping current flowing in a seal-in coil, but by means of a shunt coil controlled by the telephone relay. Trip contacts are paralleled by auxiliary contacts actuated by the target coil. There is, therefore, no seal-in action. No d-c supply is used in the auxiliary circuits. The telephone relay is connected to a rectifier supplied from the cup unit potential source, and the target and auxiliary coil circuit is wired to the same source.

The Type CFF12D is the overfrequency counterpart of the Type CFF12C. Operation is such that left contacts are closed on overfrequency, and right contacts are closed at or below rated frequency.

INTERNAL CONSTRUCTION

CUP AND STATOR

These relays are induction cylinder devices for alternating current circuits. (See Fig. 3). The principle by which torque is developed is the same as that employed in an induction-disk relay with a watt-hour meter element, though in arrangement of parts they are more like split-phase induction motors.

The stator has eight laminated magnetic poles projecting inward and arranged symmetrically around a central magnet core. The poles are wound with potential coils. In the annular air gap between the poles and central core is the cylindrical part of the cup-like aluminum rotor, which turns freely in the air gap. The central core is fixed to the stator frame; the rotor alone turns.

This construction provides higher torque and lower rotor inertia than the induction-disk construction, thus making these relays more sensitive.

CONTACT STRUCTURE

The contacts are silver-to-silver elements and are constructed with a non-bounce feature to insure a positive circuit closure. Fig. 5 shows the arrangement of the contact mechanism. The stationary contact (G) is mounted on a flat spiral spring (F) which is spaced from a thin diaphragm (C) by a washer (D). The cap (E) holds these in place on a

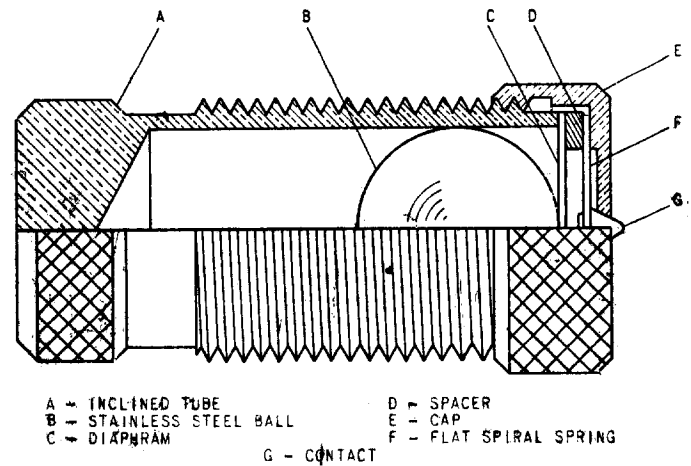

Fig. 5 (K-6077069-3) Stationary Contact Assembly

slightly inclined tube (A) which contains a close fitting stainless steel ball (B). The energy of the moving contact is transferred to the spring and steel ball with the result that there is little or no rebound or vibration of the closing contacts.

The moving contacts are supported on a molded plastic arm which is attached to the rotor shaft. The arm is held from rotating freely by a control spring. This spring maintains a slight torque in the direction to close the right-hand contacts, and so holds them closed when the relay is de-energized.

TELEPHONE RELAY UNIT

The auxiliary telephone relay unit has an armature-end copper slug on the operating coil assembly. The characteristics are such that flux buildup is retarded, and a time delay is obtained in armature action. In relay Types CFF12A and CFF12B, the contacts which are actuated by the armature perform the following functions: (1) a normally open contact completes the trip circuit, (2) a normally closed contact opens an external contactor holding circuit (if used), and (3) a normally open contact closes to seal-in the telephone relay circuit. This relay is d-c operated from the station battery.

In relay Types CFF12C and CFF12D the auxiliary telephone relay unit is operated from a full wave bridge rectifier. The contacts perform the same functions as in the CFF12A and CFF12B plus the function of completing the shunt target coil circuit to the a-c source. In addition, the normally closed contact is composed of two relay contacts in series to provide a double break and larger gap.

TARGET UNIT

Relay Types CFF12A and CFF12B have a target-seal-in unit, and Types CFF12C and CFF12D have a target and auxiliary unit which is mechanically identical to the target-seal-in unit. The unit has a coil, and a hinged armature which is attracted upward to the core when current flows in the coil. The armature carries spring-backed contacts which bridge two stationary contacts when fully picked-up. As the contacts are raised they lift an orange colored

target indicator which latches in place. The indicator is reset by means of a lever release operated from a reset button which extends through the lower left corner of the relay cover.

The case is suitable for either surface or semi-flush panel mounting and an assortment of hardware is provided for either mounting. The cover attaches to the case and also carries the reset mechanism. Each cover screw has provision for a sealing wire.

The case has studs or screw connections at the bottom for the external connections. The electrical connections between the relay unit and the case studs are made through spring backed contact fingers mounted in stationary molded inner and outer blocks between which nests a removable connecting plug which completes the circuits. The outer blocks, attached to the case, carries the studs for the external connections, and the inner block carries terminals for the internal connections.

The relay mechanism is mounted in a steel framework called the cradle and is a complete unit with all leads being terminated at the inner block. This cradle is held firmly in the case with a latch at the top and the bottom and by a guide pin at the back of the case. The case and cradle are so constructed that the relay cannot be inserted in the case upside down. The connecting plug, besides making the electrical connections between the blocks of the cradle and case, also locks the latch in place. The cover, which is fastened to the case by thumbscrews, holds the connecting plug in place.

To draw out the relay unit the cover is first removed, and the plug pulled out. The latches are then released, and the relay can be easily drawn out. To replace the relay, the reverse order is followed.

A separate testing plug can be inserted instead of the connecting plug to test the relay in place on the panel either from its own source of voltage, or from other sources. Or, the relay can be drawn out and replaced by another which has been tested in the laboratory.

INSTALLATION

LOCATION

The location should be clean and dry, free from dust and excessive vibration, and well lighted to facilitate inspection and testing.

MOUNTING

The relay should be mounted on a vertical surface. The outline and panel drilling for either surface or semiflush panel mounting is shown in Fig. 10.

CONNECTIONS

Internal connection diagrams for the relays are shown in Figs. 6 and 7. A typical wiring diagram is given in Fig. 8 for the Types CFF12A and CFF12B, and in Fig. 9 for the Types CFF12C and CFF12D.

One of the mounting studs or screws should be permanently grounded by a conductor not less than No. 12 B&S gage copper wire or its equivalent.

ADJUSTMENTS

The relays are calibrated at the factory and should not require any further adjustment. If it is desirable to check the frequency characteristic, follow the procedure outlined under MAINTENANCE.

At the time of installation of Types CFF12A and CFF12B, the proper tap setting of the target-seal-in unit should be chosen. In changing taps it is recommended that the screw from the opposite stationary contact be inserted in the vacant tap before the existing tap screw is loosened. This will preserve the factory adjustment of the contact wipe and alignment.

INSPECTION

At the time of installation, the relay should be inspected for tarnished contacts, loose screws, or other imperfections. If any trouble is found, it should be corrected in the manner described under MAINTENANCE.

MAINTENANCE

The relays are adjusted at the factory, and it is advisable not to disturb the adjustments. If for any reason they have been disturbed, the following points should be observed in restoring them.

SHAFT AND BEARINGS

The lower jewel screw can be removed from the unit by means of an offset screw driver or an end wrench. The jewel may be tested for cracks by exploring its surface with the point of a fine needle. If it is necessary to replace the jewel, a new pivot should be screwed into the bottom of the shaft at the same time.

The lower jewel bearing should be screwed all the way in until its head engages the end of the threaded core. The upper bearing should be adjusted to allow about 1/64 inch end play of the shaft.

To check the clearance between the iron core and the inside of the rotor cup, press down on the contact arm near the shaft, and thereby depress the spring mounted jewel until the cup strikes the iron. The shaft and cup should move about 1/16 inch.

CUP AND STATOR

If it is necessary to remove the rotor from the unit, the following procedure should be followed.

The leads should first be removed from the contact structure and tagged for identification in reconnecting. Then remove the three flat head screws which fasten the unit to the mounting plate from the back. Tilt the stator forward and remove the four corner screws which hold the contact head to the stator. The entire top structure with the rotor can then be lifted away from the stator to give access

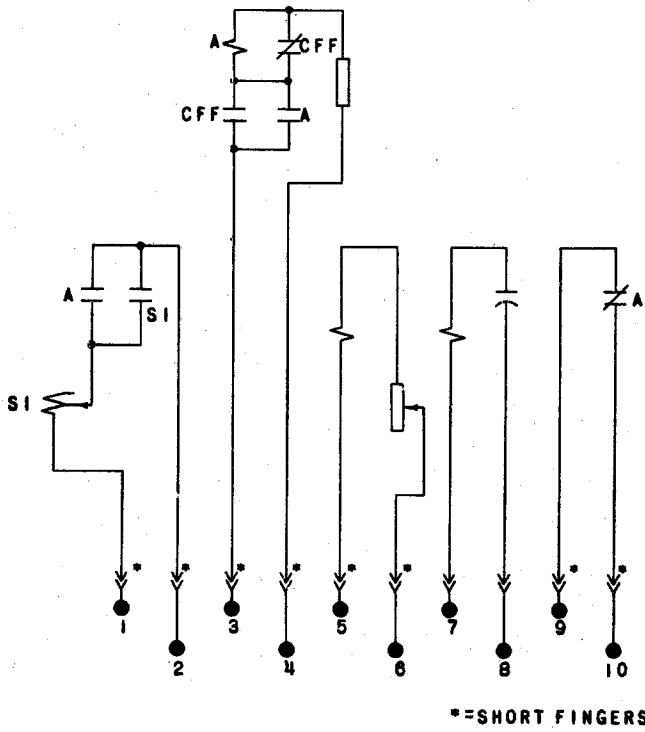

Fig. 6 (K-6375622-1) Internal Connections For Relay Types CFF12A And CFF12B

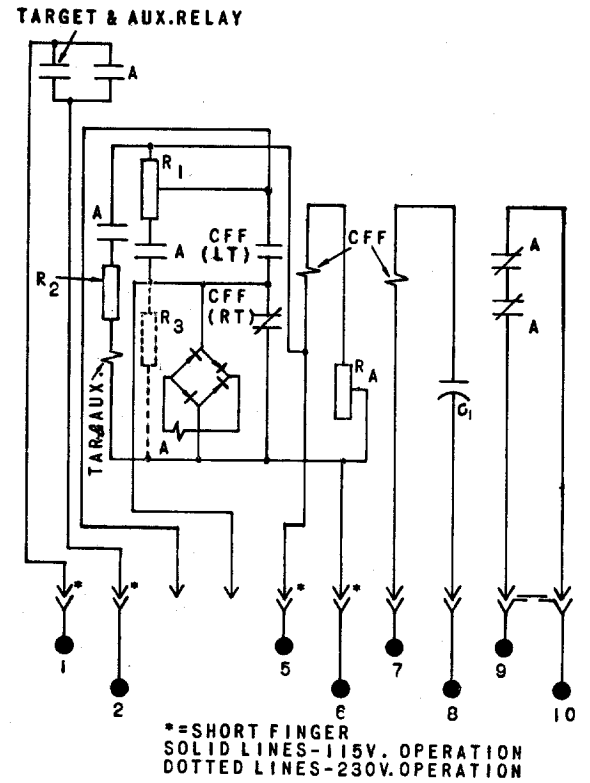

Fig. 7 (K-6556544-0) Internal Connections For Relay Types CFF12C And CFF12D

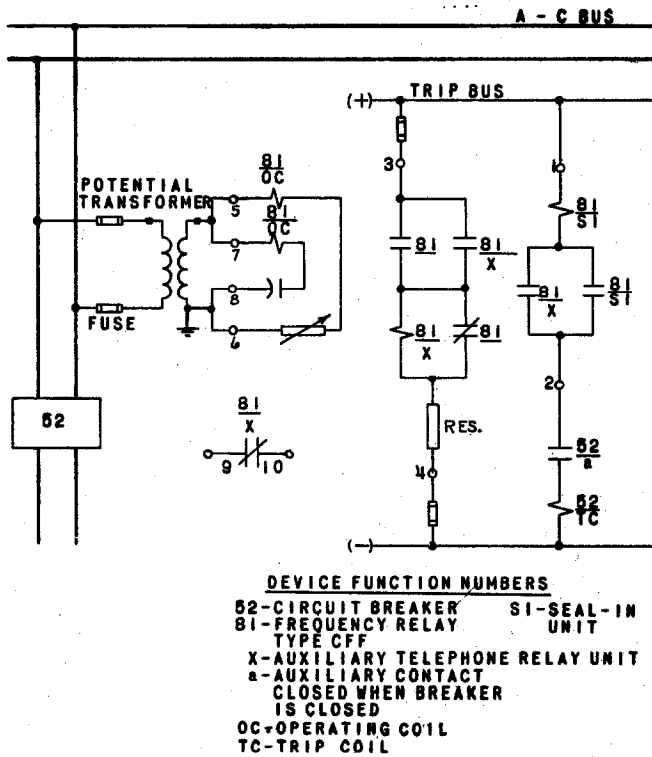

Fig. 8 (K-6375842-6) External Connections For Relay Types CFF12A And CFF12B

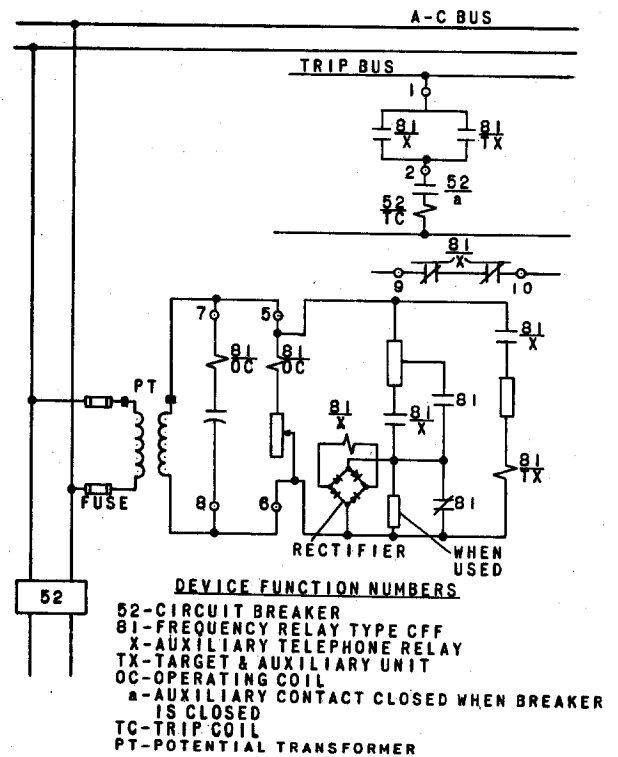

Fig. 9 (K-6556560-1) External Connections For Relay Types CFF12C And CFF12D

to the assembly. Care should be taken not to strain the leads entering the back of the stator. Unless there is reason for removing the stator from the cradle, these leads need not be disconnected.

To remove the shaft and rotor from the contact head assembly, the spring clip at the top of the shaft must be pulled out, and the clutch adjusting screw and spring taken out of the molded contact arm.

The rotor should be handled carefully while it is out of the unit, and the stator should be protected to keep it free from dust or metallic particles.

In reassembly, the rotor will fit into the air gap easily if the parts are held in proper alignment.

CONTACT CLEANING

For cleaning fine silver contacts, a flexible burnishing tool should be used. This consists of a flexible strip of metal with an etched roughened surface, resembling in effect a superfine file. The polishing action is so delicate that no scratches are left, yet corroded material will be removed rapidly and thoroughly. The flexibility of the tool insures the cleaning of the actual points of contact.

Fine silver contacts should not be cleaned with knives, files, or abrasive paper or cloth. Knives or files may leave scratches which increase arcing and deterioration of the contacts. Abrasive paper or cloth may leave minute particles of insulating abrasive material in the contacts and thus prevent closing.

The burnishing tool described is included in the standard relay tool kit obtainable from the factory.

CONTACT ADJUSTMENT

Should it be necessary to change the stationary contact mounting spring (F) (Fig. 5), remove the contact barrel and sleeve as a complete unit after loosening the screw at the front of the contact block. Unscrew the cap (E). The contact and spring may then be removed.

The moving contact may be removed by loosening the screw which secures it to the contact arm and sliding it from under the screw head.

The contact gap may be adjusted by slightly loosening the screw at the front of the contact block. It should be loose enough only to allow the contact barrel to rotate in its sleeve.

The right contact should hold the moving contact arm in a neutral position, i.e., with it pointing directly forward. Bring the left stationary contact up until it just touches the moving contact by rotating the barrel. Then back it away two full turns to

obtain 1/16 inch contact gap. Tighten the screws which secure the contact barrels.

CLUTCH ADJUSTMENT

If for any reason the moving contact arm has been removed or loosened from the rotor shaft it will be necessary to reset the clutch. The screw on the side of the contact arm should be tightened as far as possible so that the clutch is unable to slip.

CALIBRATION PROCEDURE

In order to calibrate these relays a source of variable frequency is required. The relay should be connected to the source as indicated in the external connection diagram, Fig. 8 or 9. An indicating lamp should be substituted for the breaker trip coil.

With the relay de-energized, the control spring should be adjusted as follows:

1. Complete the contact adjustments as described previously.
2. Loosen the hexagonal locking screw which holds the back of the adjusting ring.
3. Turn the adjusting ring until the right contacts just part.
4. Turn the adjusting ring in the opposite direction (to close right contacts) 3/16 inch measured on its periphery for under frequency relays (CFF12A and 12C), or 1/2 inch for overfrequency relays (CFF12B and 12D). Tighten the hexagonal locking screw.
5. Apply rated voltage at tripping frequency to the cup unit.
6. Adjust the rheostat until the left contacts just close.

PERIODIC TESTING

An operational test and inspection of the relay at intervals of six months is recommended. The calibration need not be checked, but operation of the auxiliary circuits should be tested.

In testing relay Types CFF12A and CFF12B, an adjustable resistor should be substituted for the breaker trip coil. It should be set to draw current equal to 95 per cent of tap setting of the target-seal-in unit. When testing relay Types CFF12C and CFF12D, an indicating lamp should be used in place of the breaker trip coil.

To check operation of the auxiliary circuits follow the sequence tabulated on Table V.

TABLE V

RELAY	OPERATE SUCCESSIVELY BY HAND			
	1. Close Left Contacts	2. Open Left Contacts	3. Close Right Contacts	4. Open Trip Circuit
RESULT				
CFF12A & 12B	Telephone relay picks up, target-seal-in picks up, trip current flows.	No Action	Telephone relay drops out.	Target - seal - in drops out. Target remains exposed.
CFF12C & 12D	Telephone relay picks up, target and auxiliary relay picks up, indicating lamp lights.	No Action	Telephone relay drops out, target and auxiliary relay drops out, target remains exposed, indicating lamp extinguishes.	No Action

RENEWAL PARTS

It is recommended that sufficient quantities of renewal parts be carried in stock to enable the prompt replacement of any that are worn, broken, or damaged.

When ordering renewal parts, address the nearest Sales Office of the General Electric Company, specify quantity required, name of part wanted, and give complete nameplate data of the relay. If possible, give the General Electric Company requisition number on which the relay was furnished.

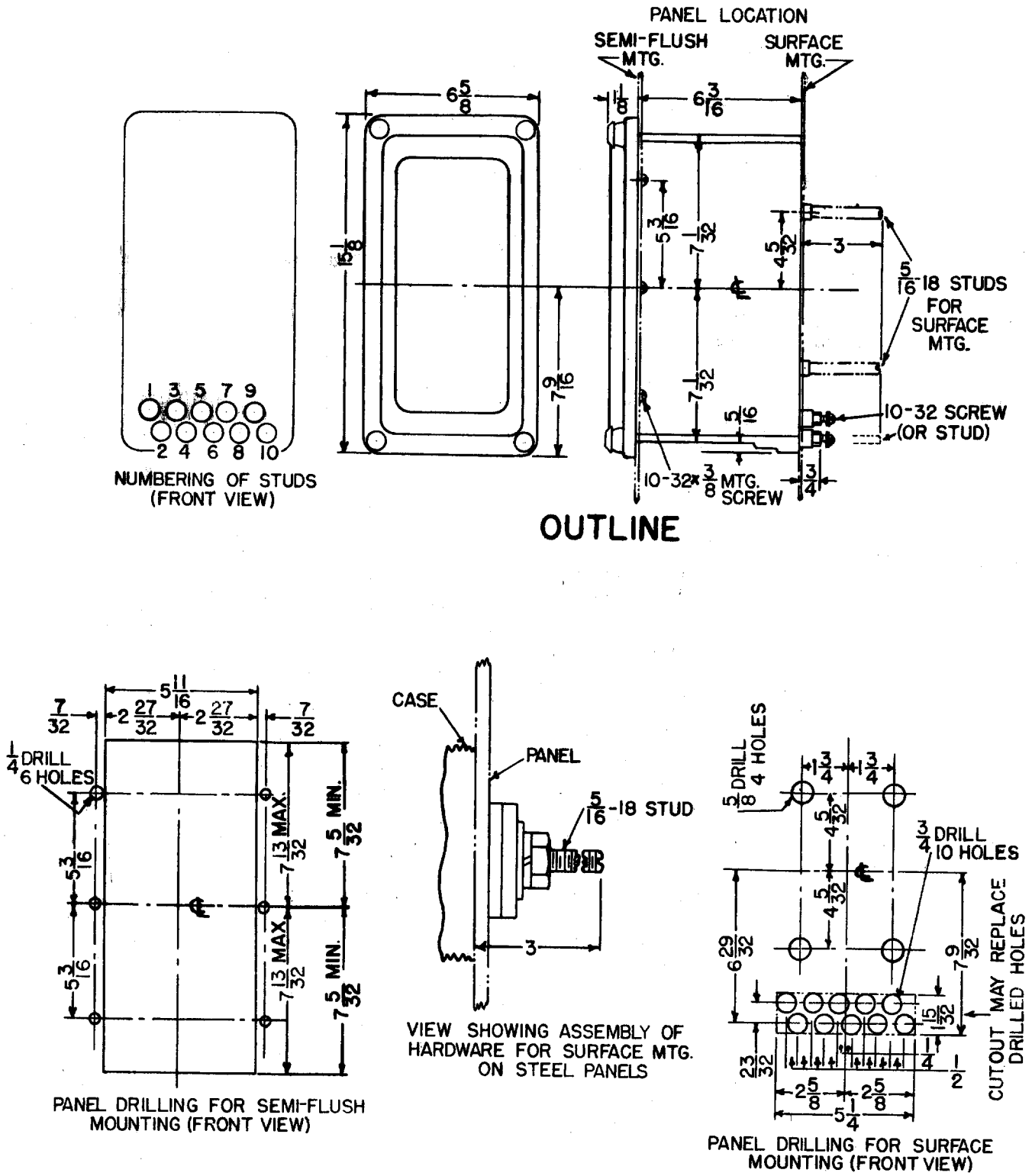

Fig. 10 (K-6209273-2) Outline And Panel Drilling Dimensions For Type CFF Relays