

INSTRUCTIONS

GEI-31030D
Supersedes GEI-31030C



VOLTAGE BALANCE RELAY

Type CFVB11A

POWER SYSTEMS MANAGEMENT DEPARTMENT

GENERAL  ELECTRIC

PHILADELPHIA, PA.

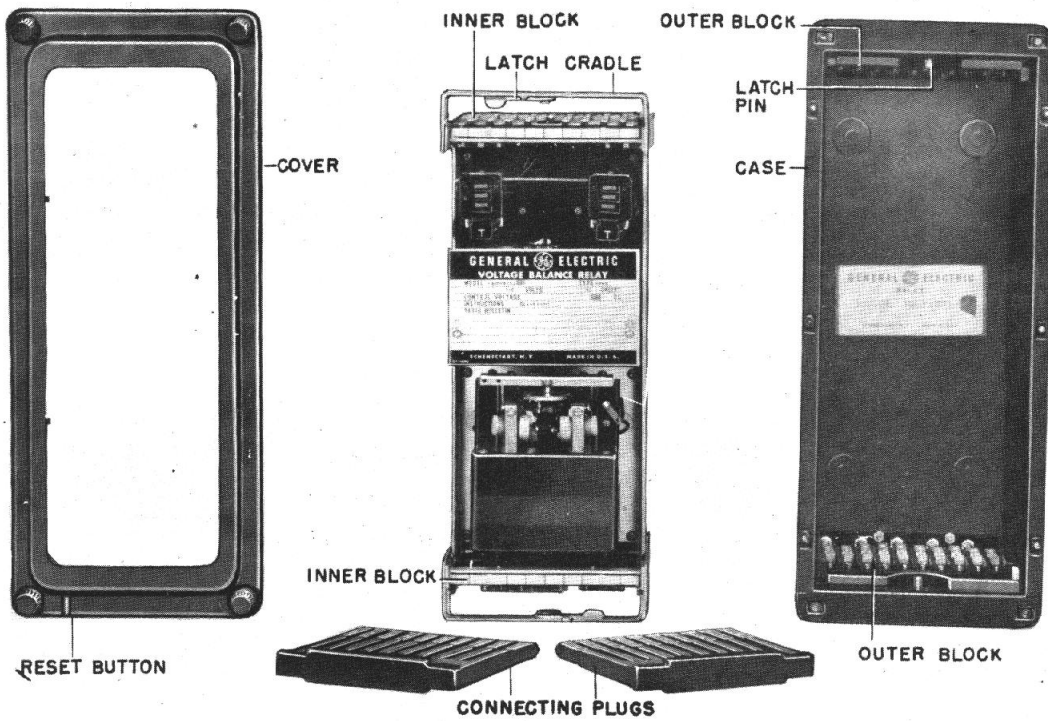

Figure 1. (8013052) The Type CFVB11A Relay Disassembled

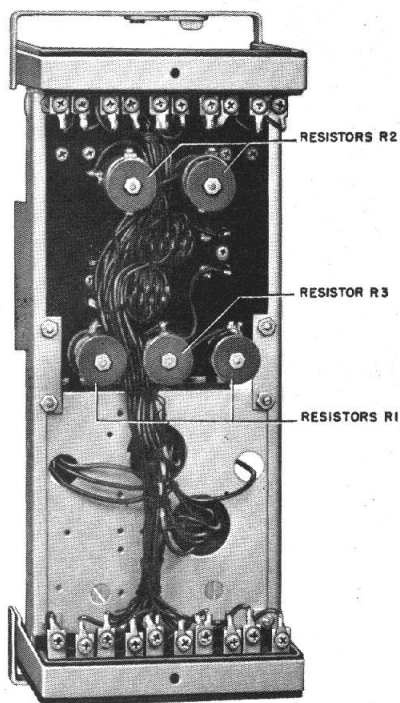

Figure 2. (8013053) Type CFVB11A Relay, Unit in Cradle (Rear View)

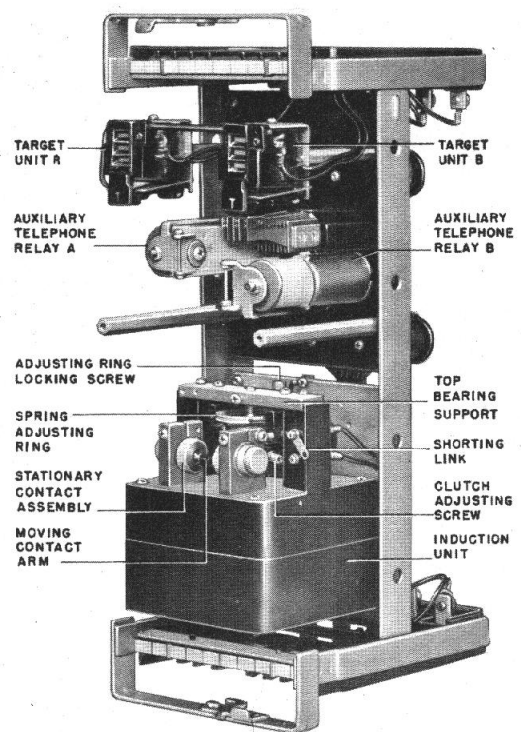

Figure 3. (8013055) Type CFVB11A Relay, Unit in Cradle Without Nameplate (Front View)

VOLTAGE BALANCE RELAY TYPE CFVB11A

INTRODUCTION

APPLICATION

The Type CFVB11A voltage balance relay is used to block relays or other devices that will operate incorrectly when a potential transformer fuse blows. The relay is supplied with three-phase voltage from two sets of potential transformers. If the three-phase voltages from the two sets of potential transformers are balanced, the contacts of the voltage balance relay remain in the float position (where both contacts of the relays are open) regardless of the magnitude of the voltages. If a fuse blows in any phase of one set of potential transformers, this will cause the relay to operate to close the left contacts. These contacts then pick up an auxiliary relay that has one normally open and two normally closed contacts. If a fuse blows in any phase of the other set of potential transformers, the relay operates to close the right-hand contacts. These contacts then pick up another auxiliary relay which also has one normally open contact and two normally closed contacts. The normally open contacts of the auxiliary relays are usually used to ring an alarm, and the normally closed contacts are used to open the trip circuits of relays subject to misoperation. Some of the relays and devices that may have to be blocked to prevent them from operating incorrectly when a potential transformer fuse blows are voltage restraint overcurrent relays, synchronizing relays and voltage regulators.

OPERATING CHARACTERISTICS

The relay unit can be adjusted to close its right contacts (front view) when the three-phase voltage applied to studs 5-6-7 is dropped to any value between 50 per cent and 95 per cent of the rated voltage when rated voltage is maintained on studs 15-16-17. The left contacts (front view) can be adjusted to close when the three-phase voltage applied to studs 15-16-17 is dropped to any value between 50 per cent and 95 per cent of the rated voltage when rated voltage is maintained on studs 5-6-7.

Each voltage source produces a torque which is proportional to the area of the three-phase voltage triangle, whether or not the voltages are balanced. Fig. 4 shows the characteristic of the relay with the factory calibration of contact closure when one source voltage is normal and the other source voltage is dropped to 96 volts (80 per cent of rated voltage). Balanced three-phase voltages are maintained for these curves. The characteristic can be applied to unbalanced three-phase conditions by calculating the areas of the voltage triangles of the two sources, and determining the two balanced three-phase voltages which would form triangles of areas equal to them. These two voltages can be used to locate a point on Fig. 4 to determine whether or not the relay will pick up. This characteristic curve is applicable only when the

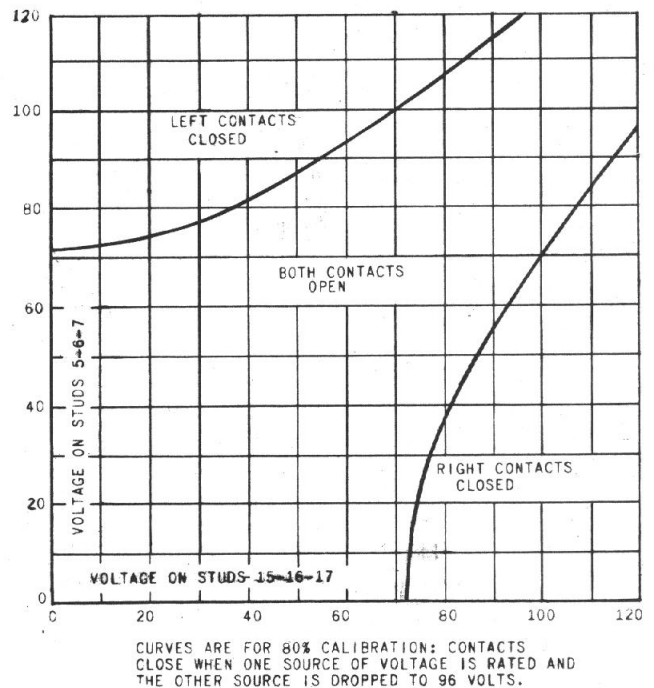

Figure 4. (6507983-1) Typical Operating Characteristic of the Type CFVB11A Relay

relay is calibrated as stated.

The time required for the normally closed contacts of the auxiliary relays to reclose from the fully picked up position is adjusted at the factory to be greater than 200 milliseconds. This time is sufficient to assure that a voltage restraint overcurrent relay has opened its trip circuit upon restoration of the voltage supply before the Type CFVB relay gives permission to trip.

BURDENS

The burdens of the potential circuits at 120 volts are as follows:

Circuit	Frequency (Cycles)	Impedance (Ohms)	P.F.	V.A.
5-6	60	5075	0.97	2.83
6-7		2240	0.97	6.43
15-16		5075	0.97	2.83
16-17		2240	0.97	6.43
5-6	50	5080	0.97	2.83
6-7		2155	0.97	6.68
15-16		5080	0.97	2.83
16-17		2155	0.97	6.68

These instructions do not purport to cover all details or variations in equipment nor to provide for every possible contingency to be met in connection with installation, operation or maintenance. Should further information be desired or should particular problems arise which are not covered sufficiently for the purchaser's purposes, the matter should be referred to the General Electric Company.

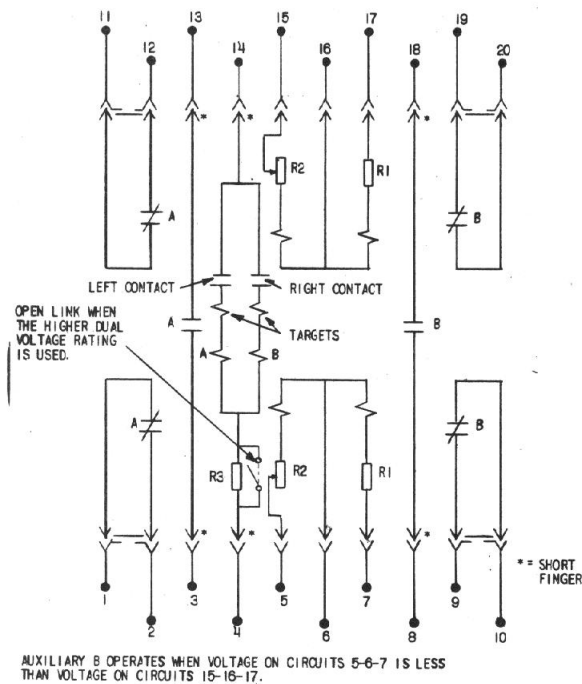

Figure 5. (K-6375830-4) Internal Connections for the Type CFVB11A Relay (Front View)

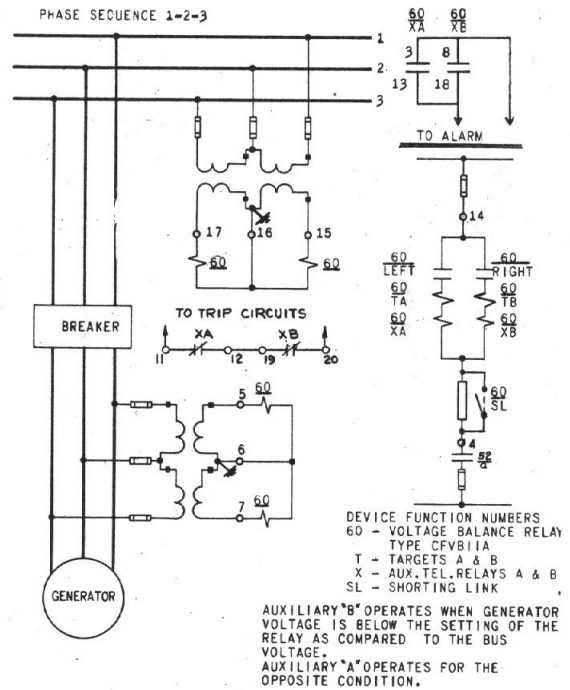

Figure 6. (6375857-7) External Wiring Diagram of the Type CFVB11A Relay

RECEIVING, HANDLING AND STORAGE

These relays, when not included as a part of a control panel will be shipped in cartons designed to protect them against damage. Immediately upon receipt of a relay, examine it for any damage sustained in transit. If injury or damage resulting from rough handling is evident, file a damage claim at once with the transportation company and promptly notify the nearest General Electric Apparatus Sales Office.

Reasonable care should be exercised in un-

packing the relay in order that none of the parts are injured or the adjustments disturbed.

If the relays are not to be installed immediately, they should be stored in their original cartons in a place that is free from moisture, dust and metallic chips. Foreign matter collected on the outside of the case may find its way inside when the cover is removed and cause trouble in the operation of the relay.

DESCRIPTION

INTERNAL CONSTRUCTION

INDUCTION UNIT

The operating element of the Type CFVB relay is the induction cylinder unit, a torque producing device for use in alternating current circuits. The principle by which torque is developed is the same as that employed in an induction-disk relay with a watt-hour-meter element, though in arrangement of parts it is more like a split-phase induction motor.

The stator has eight laminated magnetic poles projecting inward and arranged symmetrically around a central magnetic core. Six of the poles are wound with potential coils. In the annular air gap be-

tween the poles and the central core is the cylindrical part of the cup-like aluminum rotor, which turns freely in the air gap. The central core is fixed to the stator frame; the rotor alone turns.

This construction provides higher torque and lower rotor inertia than the induction disk construction. These factors result in faster and more sensitive operation than can be obtained from the induction disk type of operating unit.

CONTACT STRUCTURE

The contacts are silver-to-silver elements and are constructed with a non-bounce feature to insure a positive circuit closure. Fig. 7 shows the arrange-

ment of the contact mechanism. The stationary contact (G) is mounted on a flat spiral spring (F) which is spaced from a thin diaphragm (C) by a washer (D). The cap (E) holds these in place on a slightly inclined tube (A) which contains a close fitting stainless steel ball (B). The energy of the moving contact is transferred to the spring and steel ball with the result that there is little or no rebound or vibration of the closing contacts.

The moving contacts are supported on a molded plastic arm which is attached to the rotor shaft. The arm is held from rotating freely by a control spring which keeps it in a neutral position when the induction unit torques are balanced.

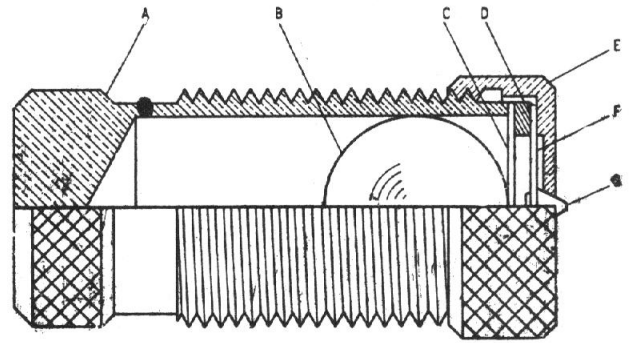

Figure 7. (K-6077069-3) Stationary Contact Assembly.

AUXILIARY UNITS

The auxiliary telephone relay units each have a heel-end copper slug on the operating coil assembly. The characteristics are such that the decay of flux is retarded, and a time delay is obtained in armature dropout.

Each telephone relay has a target auxiliary-unit coil in series with its coil. The target unit is a hinged armature type of relay. When picked up by completion of the associated telephone relay circuit, an orange colored target indicator is exposed. This indicator latches in place, and is reset by means of a lever release operated from a reset button which extends through the lower left corner of the relay cover (see Fig. 1). The reset mechanism is common to both target units.

A series resistor (R3) is used to limit the auxiliary circuit current for the higher of the dual voltage ratings. This resistor is shorted for the lower rating by a shorting link located on the right-hand upright of the molded upper bearing support of the cup unit. Interrupting rating of auxiliary relay contacts "A" and "B":

0.25 Amperes at 250 volts d-c
0.50 Amperes at 125 volts d-c

CASE

The case is suitable for either surface or semi-flush panel mounting and an assortment of hardware is provided for either mounting. The cover attaches to the case and also carries the reset mechanism. Each cover screw has provision for a sealing wire.

The case has studs or screw connections at both ends for the external connections. The electrical connections between the relay units and the case studs are made through spring backed contact fingers mounted in stationary molded inner and outer blocks, between which nests a removable connecting plug which completes the circuits. The outer blocks, attached to the case, have the studs for the external connections, and the inner blocks have the terminals for the internal connections.

The relay mechanism is mounted in a steel framework called the cradle and is a complete unit with all leads being terminated at the inner blocks. The cradle is held firmly in the case with a latch at the top and the bottom and by a guide pin at the back of the case. The case and cradle are so constructed that the relay cannot be inserted in the case upside down. The connecting plugs, besides making the electrical connections between the respective blocks of the cradle and case, also lock the latches in place. The cover, which is fastened to the case by thumbscrews, holds the connecting plugs in place.

To draw out the relay unit the cover is first removed, and the plugs are drawn out. The latches are then released, and the relay unit can be easily drawn out.

A separate testing plug can be inserted in the place of either of the connecting plugs to test the relay in place on the panel either from its own source of voltage, or from another source. Or, the relay unit can be drawn out and replaced by another which has been tested in the laboratory.

INSTALLATION

LOCATION

The location should be clean and dry, free from dust and excessive vibration, and well lighted to facilitate inspection and testing.

MOUNTING

The relay should be mounted on a vertical surface. The outline and panel drilling dimensions for

either surface or semi-flush panel mounting are shown in Fig. 8.

CONNECTIONS

The internal connection diagram for the relay is shown in Fig. 5. A typical wiring diagram is shown in Fig. 6.

One of the mounting studs or screws should be

permanently grounded by a conductor not less than No. 12 B & S gage copper wire or its equivalent.

INITIAL ADJUSTMENT

PICKUP CALIBRATION

The induction cylinder unit calibration can be changed by increasing or decreasing the contact gap.

The control spring should always be set to hold the contact arm so that it is parallel to the sides of the relay unit when the unit is completely de-energized. Rated three-phase voltage should then be applied to both sets of potential studs, and the contact arm should remain approximately parallel to the sides of the relay. If this does not occur with balanced voltages applied, an adjustment of the torque balance resistors is necessary. The procedure is described under MAINTENANCE. The three-phase voltage to studs 5-6-7 should then be reduced to the value at which it is desired to have the right contacts close. The contact arm will move to the right. When the contact arm has taken its new position, turn the right contact barrel until the contacts just make. Then, lock the right contact barrel in this position. Increase the voltage to studs 5 to 7 back to normal, and decrease the voltage to studs 15-16-17 to the value at which it is desired to have the left

contacts close. When the contact arm has moved to the left and taken its new position, turn the left contact barrel until the contacts just close. Then lock the left contact barrel.

The phase sequence should be 1-2-3 in order to have a small variation in dropout over a 360 degree range of phase angle between the two voltages.

AUXILIARY CIRCUIT RATING

At the time of installation the shorting link position should be checked. Incorrect location of this link will result in either damage to the relay, or failure to operate properly. For the higher of the dual voltage ratings of the auxiliary circuit, the link should be placed in a position in which it does not short circuit the series resistor. This may easily be done by removing one of the screws and rotating the link.

INSPECTION

At the time of installation, the relay should be inspected for tarnished contacts, loose screws, or other imperfections. If any trouble is found it should be corrected in the manner described under MAINTENANCE.

MAINTENANCE

The relays are adjusted at the factory, and it is advisable not to disturb the adjustments. If for any reason they have been disturbed, the following points should be observed in restoring them.

CUP AND STATOR

If it is necessary to remove the rotor from the unit, the following procedure should be followed. (Refer to Figs. 2 and 3).

The leads should first be removed from the contact structure and tagged for identification in reconnecting. Then remove the three flat-head screws which fasten the unit to the mounting plate from the back. Tilt the stator forward and remove the four corner screws which hold the contact head to the stator. Avoid any disturbance to the top bearing support. The entire top structure with the rotor can then be lifted away from the stator to give access to the assembly. Care should be taken not to strain the leads entering the back of the stator. Unless there is reason for removing the stator from the cradle, these leads need not be disconnected.

To remove the shaft and rotor from the contact head assembly, the spring clip at the top of the shaft must be pulled out, and the clutch adjusting screw and spring taken out of the molded contact arm.

The rotor should be handled carefully while it is out of the unit, and the stator should be protected to keep it free from dust or metallic particles.

In reassembly, the rotor will go into the air gap easily if the parts are held in proper position. The dowel pins will serve to restore the original alignment.

CLUTCH ADJUSTMENT

If for any reason the moving contact arm has been removed or loosened from the rotor shaft it will be necessary to reset the clutch. The screw on the side of the contact arm should be tightened as far as possible so that the clutch is unable to slip.

SHAFT AND BEARINGS

The lower jewel screw can be removed from the unit by means of an offset screw driver or an end wrench. The jewel may be tested for cracks by exploring its surface with the point of a fine needle. If it is necessary to replace the jewel, a new pivot should be screwed into the bottom of the shaft at the same time.

The lower jewel bearing should be screwed all the way in until its head engages the end of the core. The upper bearing should be adjusted to allow about 1/64 inch end play of the shaft.

To check the clearance between the iron core and the inside of the rotor cup, press down on the contact arm near the shaft, and thereby depress the spring mounted jewel until the cup strikes the iron. The shaft and cup should move about 1/16 inch.

CONTACT CLEANING

For cleaning fine silver contacts, a flexible burnishing tool should be used. This consists of a flexible strip of metal with an etched roughened surface, resembling in effect a superfine file. The pol-

ishing action is so delicate that no scratches are left, yet corroded material will be removed rapidly and thoroughly. The flexibility of the tool insures the cleaning of the actual points of contact. Sometimes an ordinary file cannot reach the actual points of contact because of some obstruction from some other part of the relay.

Fine silver contacts should not be cleaned with knives, files, or abrasive paper or cloth. Knives or files may leave scratches which increase arcing and deterioration of the contacts. Abrasive paper or cloth may leave minute particles of insulating abrasive material in the contacts and thus prevent closing.

The burnishing tool described is included in the standard relay tool kit obtainable from the factory.

CONTACT ADJUSTMENT

Should it be necessary to change the stationary contact mounting spring (F, Fig. 7), remove the contact barrel and sleeve as a complete unit after loosening the screw at the front of the contact block. Unscrew the cap (E). The contact and its flat spiral mounting spring may then be removed. Correct adjustment of the spring is such as to provide a .004 to .009 inch movement of the stationary contact (G) from the point of contact closure to the point at which it touches the tin diaphragm (C).

The moving contact may be removed by loosening the screw which secures it to the contact arm and sliding it from under the screw head.

The contact gap must be reset following these adjustments. Correct pickup calibration is dependent upon gap. Calibration procedure is described

RENEWAL PARTS

It is recommended that sufficient quantities of renewal parts be carried in stock to enable the prompt replacement of any that are worn, broken, or damaged.

When ordering renewal parts, address the near-

est Sales Office of the General Electric Company,

TORQUE BALANCE ADJUSTMENT

under INITIAL ADJUSTMENTS.

This is a factory adjustment and should not require further attention. However, if damage to the relay has occurred which affects the induction unit circuit, a readjustment may be necessary.

Torque unbalance is indicated when the contact arm moves appreciably from the deenergized central position with the application of rated three-phase balanced voltage of proper relative phase sequence (see Fig. 6) on both sets of studs. To correct the unbalance first remove all supply voltages. Connect studs 5 and 7 together and apply single phase rated voltage from stud 6 to studs 5 and 7. Adjust the right-hand (rear view) resistor R2 until the contact arm returns to the neutral position. Remove the voltage and perform same operation on studs 15, 16, and 17, connecting studs 15 and 17 together, and adjusting the left-hand resistor R2.

PERIODIC TESTS

An operational test and inspection of the relay at intervals of six months is recommended. A simple periodic test can be made on the induction unit by removing one connecting plug. If the lower connecting plug is removed, the right contacts of the unit should close. When the plug is replaced, the contact arm should move to a position where both contacts are open. Then, if the upper connecting plug is removed, the left contacts should close. Operation of the auxiliary relays is prevented in each case by the opening of the supply circuit. A test of the operation of these relays should be made by manually closing the cup unit contacts. The targets should also operate in this test.

est Sales Office of the General Electric Company, specify quantity required, name of part wanted, and give complete nameplate data, including serial number. If possible, give the General Electric Company requisition number on which the relay was furnished.

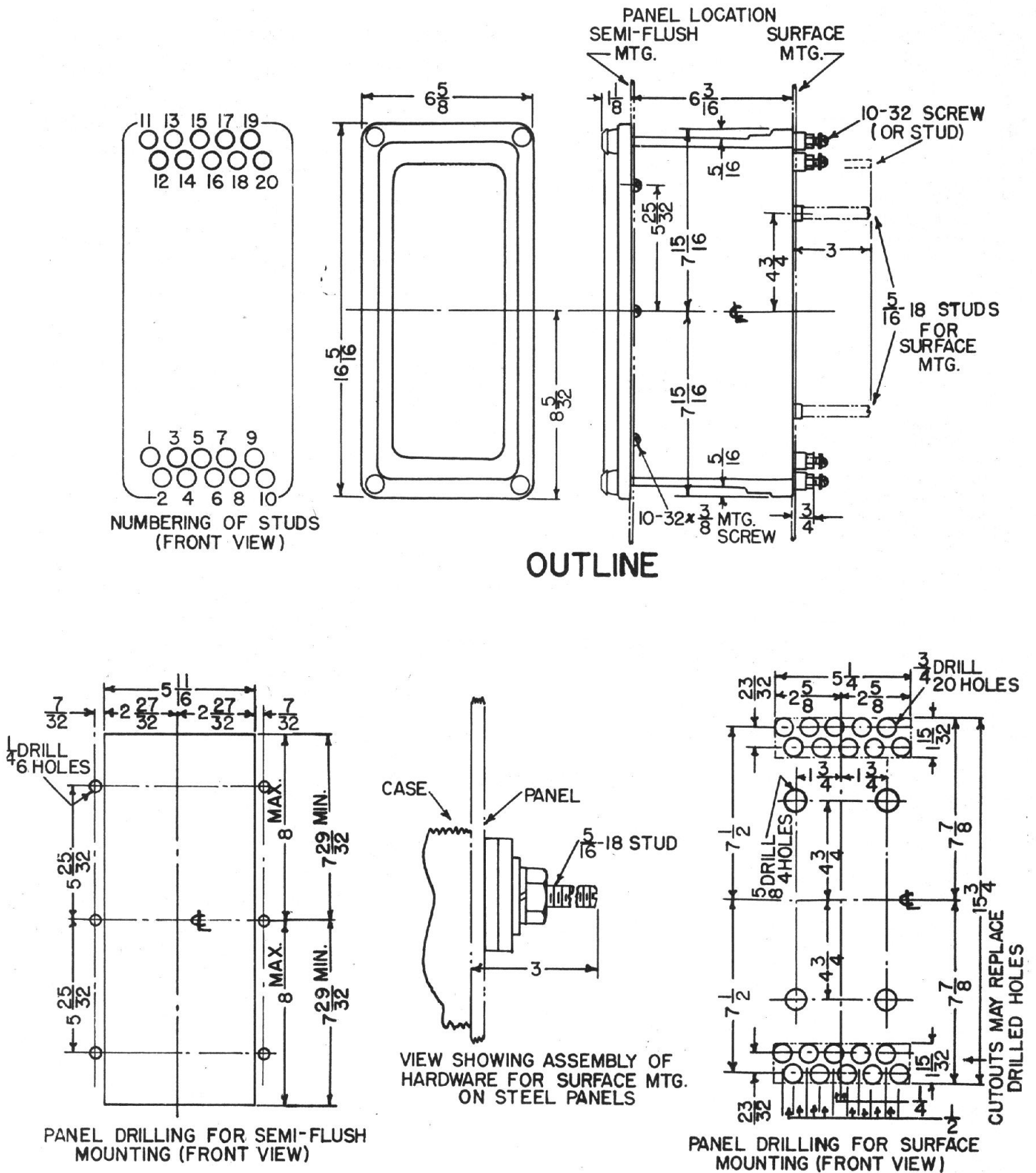

Figure 8.. (K-6209274-2) Outline and Panel Drilling for the Type CFVB11A Relay