



INSTRUCTIONS

GEI-33915C

SUPERSEDES GEI-33915B

CARRIER CURRENT GROUND RELAY



Type CKPG

LOW VOLTAGE SWITCHGEAR DEPARTMENT

GENERAL  ELECTRIC

PHILADELPHIA, PA.

A

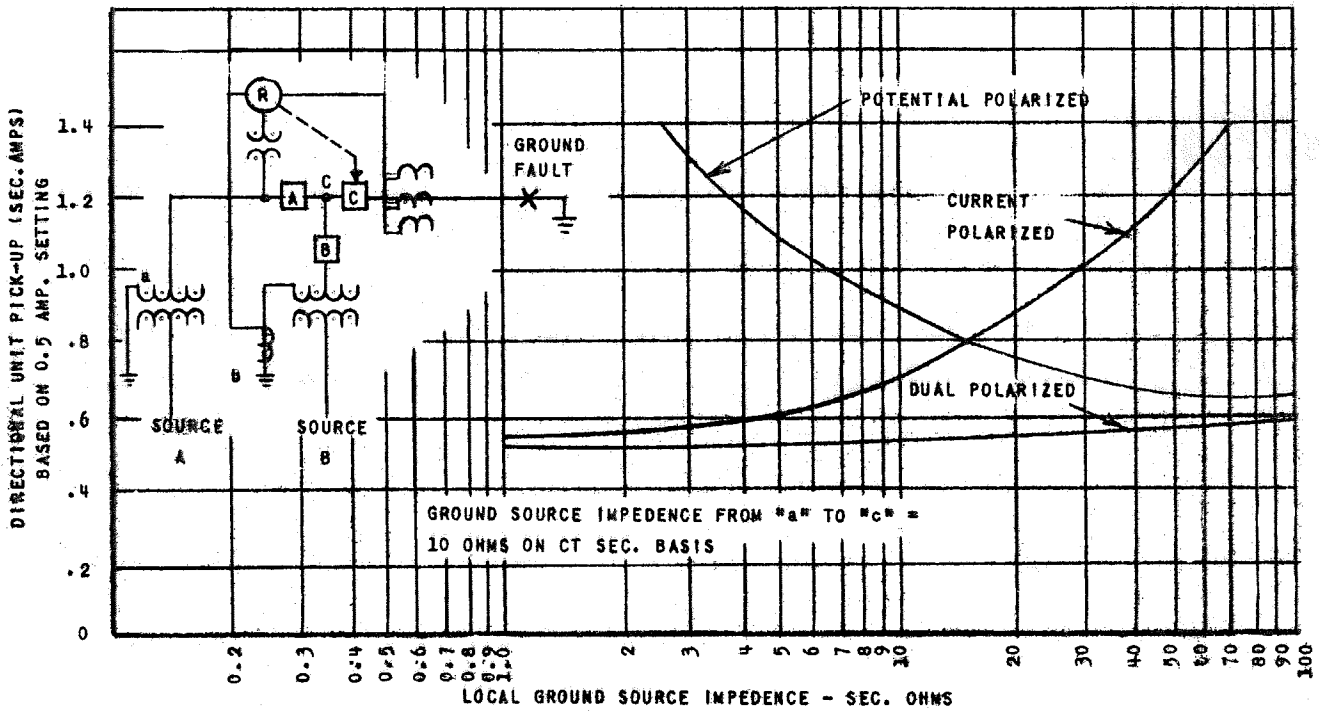
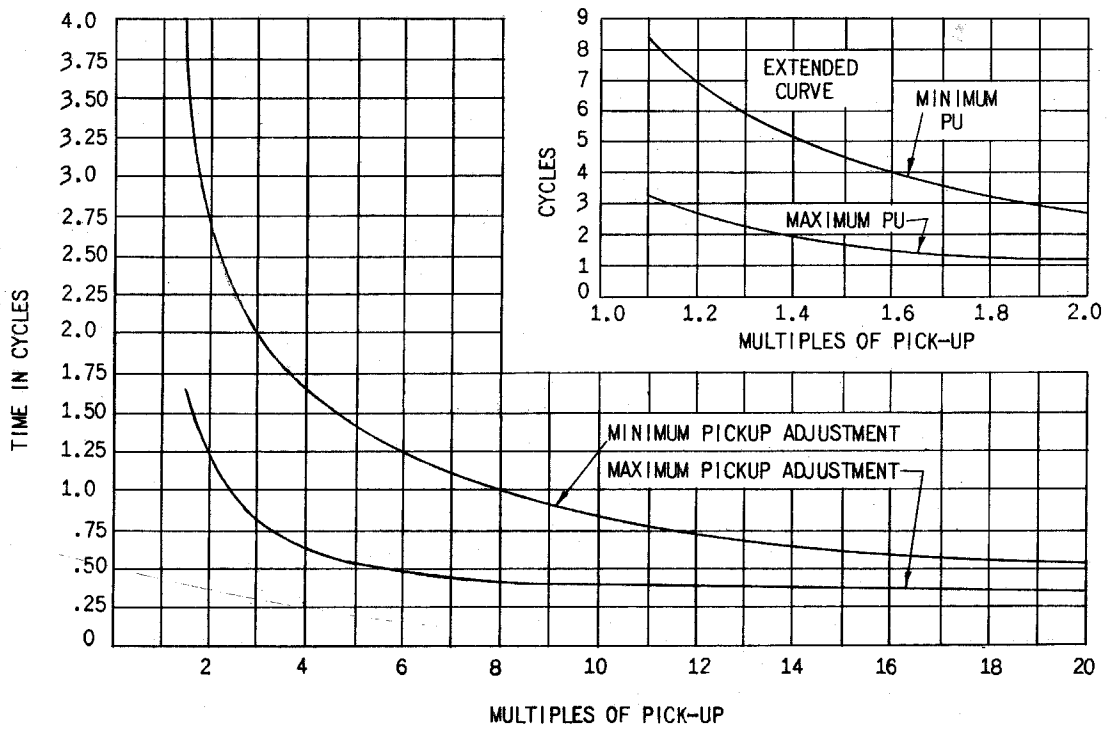

Fig. 1 Minimum Fault Current Vs. Local Ground Source Impedance To Operate Type CKPG Directional Unit For Potential, Current, Or Dual Polarization



* Fig. 2 Time-Current Characteristics Of The Overcurrent Units Of Type CKPG Relay

CARRIER CURRENT GROUND RELAY TYPE CKPG

INTRODUCTION

APPLICATION

The Type CKPG relay is a ground relay for directional-comparison, carrier-relaying applications. Carrier-current transmission is controlled by directional units. For this reason, the relay is well suited for three-ended line protection.

A non-directional overcurrent unit (G2) supervises the trip circuit. Contacts of this unit prevent completion of the circuit unless current of fault magnitude flows in the protected line. The operating current is the CT residual current (zero sequence component of line current) which results from unbalanced three-phase currents.

The directional characteristic of the carrier starting unit (GD1) and tripping unit (GD2) is provided by a dual-polarizing circuit which uses either the current in the neutral of a grounded power transformer for current polarization, or the potential across the open corner of a broken-delta potential transformer for potential polarization, or both simultaneously. Operating current is the same residual current used in the overcurrent unit. The curves in Fig. 1 compare the performance of the units when dual polarized, and when current or potential polarized for a typical ground source impedance.

The pick-up setting of the G2 unit should be such that operation is assured for minimum fault conditions for which tripping is required. The product pick-up setting of GD2 is determined from the conditions which result in minimum product input when tripping is required. It is to be noted that this does not necessarily occur for minimum fault conditions.

* The carrier current unit, GD1, in terms of product pickup, provides a blocking signal for faults external of the protected section. It should therefore be set so that for any external fault the GD1 unit receives a higher multiple of product pickup by at least 50 percent, than the GD2 unit at the other end of the protected section. Calculations should be based on the conditions that produce the maximum possible input to the GD2 and the minimum possible input to GD1. For 3-terminal lines this minimum ratio must be obtained or exceeded for any external fault location even if the outgoing fault current is divided between two terminals. For further details concerning co-ordination, refer to carrier-current Pilot Relaying instruction book GEI-25363.

OPERATING CHARACTERISTICS

The overcurrent unit of the relay, G2, has the time-current characteristic shown in Fig. 2. The operating time is somewhat dependent upon pick-up setting, but lies between the two extremes shown

for minimum (slowest) and maximum pick-up current levels. This unit has a phase shifting winding connected across a capacitor which provides the out-of-phase flux necessary to produce torque. The result is a low burden and insensitivity to harmonics.

The directional units of the relay, GD1 and GD2, have the operating-time characteristics shown in Figs. 3 and 4 for current polarization and potential polarization. Fig. 3 shows the contact closing time of the GD1 and GD2 units, while Fig. 4 shows the contact opening time of the GD1 unit. The times given are maximum, and correspond to minimum pickup. Higher pick-up levels result in faster times. The potential-polarization curves apply to a voltage-current phase relation which produces maximum closing torque. Maximum torque occurs when the residual current lags the broken delta voltage by 60 degrees for GD2 or leads by 120 degrees for GD1.

An auxiliary telephone-relay unit, GD1X, is controlled by GD1. Operation of GD1 energizes GD1X, which then picks up in 2 cycles (60 cycle basis) if GD1 remains picked up for that time. Subsequent dropout of GD1 de-energizes GD1X, which then drops out after 5 cycles. This auxiliary unit is used to maintain carrier transmission and thereby block tripping which might otherwise result from transient conditions existing during the clearing of an external fault. The 2-cycle pick-up delay prevents prolonged carrier transmission in cases where switching transients or similar disturbances cause momentary operation of GD1.

RATINGS

The current coils of the overcurrent and directional units are rated at 5 amperes. The potential coils have an intermittent (4 minute) rating of 120 volts. The maximum rating of the operating or current polarizing coil is 100 amperes. The 2-second thermal rating of either coil is also 100 amperes.

The telephone auxiliary relay circuit is designed with a dual voltage rating, such as 110/220 or 125/250. A short-circuiting link, accessible from the front of the relay, is provided for easy selection of either rating.

PICKUP RANGE		PRODUCT PICK-UP	
Unit	Operating Current	IXI when Current Polarized	EXI when Potential Polarized
GD1 (Top)	0.5-2 +	0.25-4.0	3.6-57.6
G2 (Mid)	0.5-2	---	---
GD2 (Bot)	0.5-2 +	0.25-4.0	3.6-57.6

+ Operating and current polarizing coils in series.

These instructions do not purport to cover all details or variations in equipment nor to provide for every possible contingency to be met in connection with installation, operation or maintenance. Should further information be desired or should particular problems arise which are not covered sufficiently for the purchaser's purposes, the matter should be referred to the General Electric Company.

* Denotes change from superseded issue.

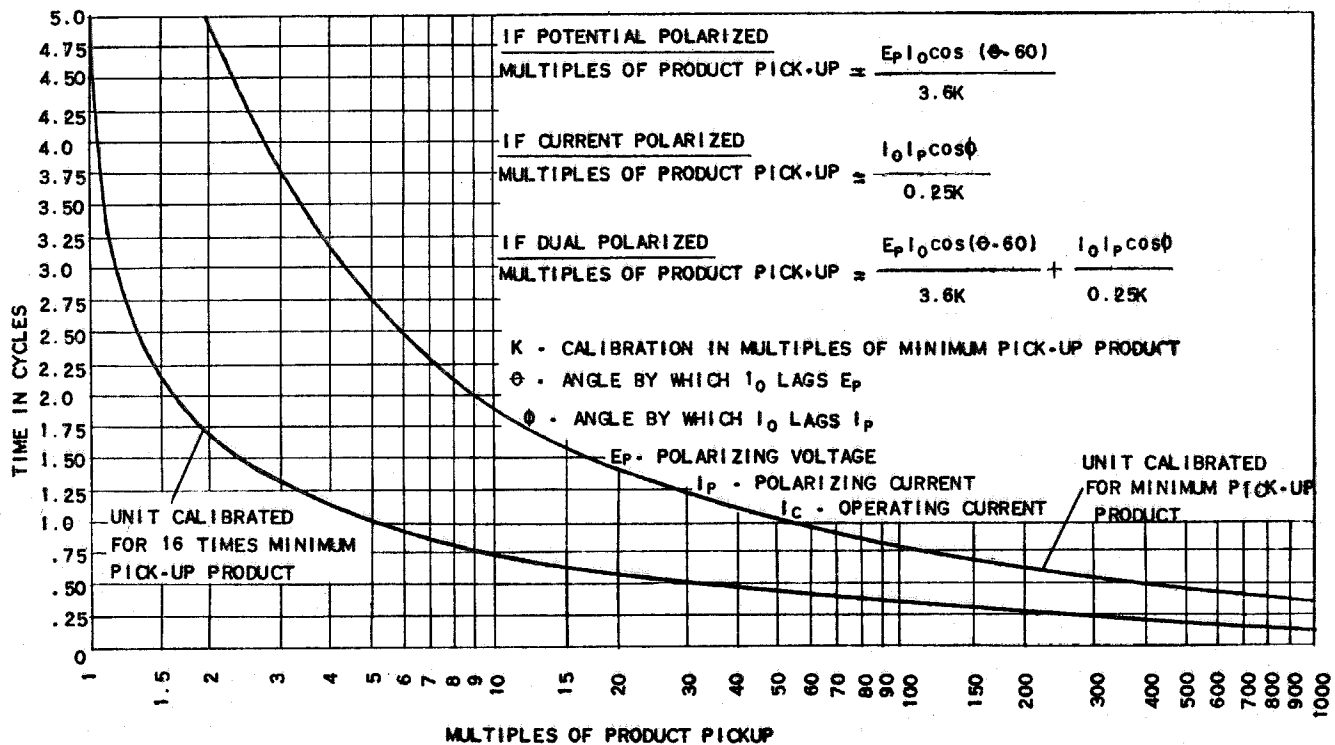

Fig. 3 Time Characteristics Of Dual-Polarized Directional Units GD1 And GD2, Contact Closing Time

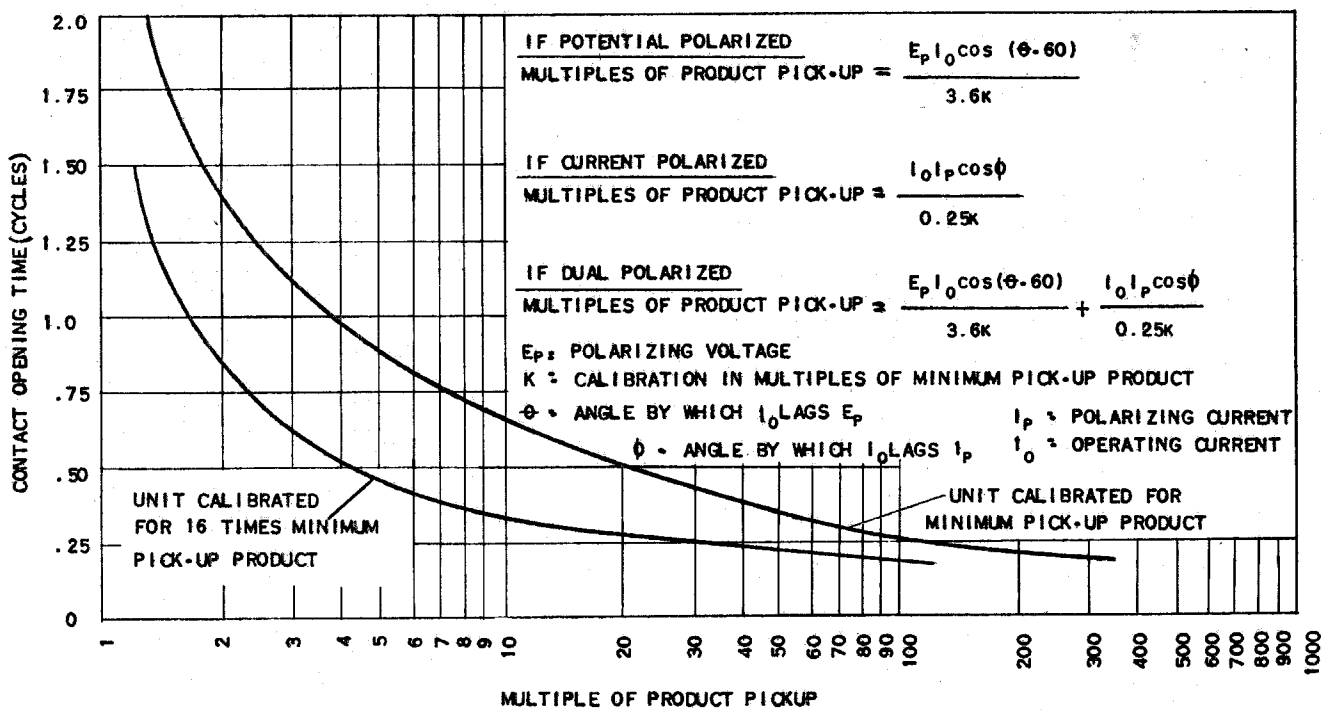

Fig. 4 Time Characteristics Of Dual-Polarized Directional Unit in Type CKPG Relay (Contact Opening Time Of GD1 And GD2 Unit)

Fig. 3 (362A592)

Fig. 4 (376A940)

TARGET AND SEAL-IN COILS

Type CKPG relay is available with one-ampere target and seal-in coil ratings. The single rating is necessary in order for the relays to work properly with other units in the carrier-current, pilot-relaying circuits. The resistances of the seal-in and target coils are each 0.25 ohms. If tripping is to be performed through an auxiliary relay, it is recommended that the auxiliary relay coil be shunted with a suitable resistance in order that sufficient trip current will flow to operate the target and seal-in units.

The one-ampere target and seal-in coil ratings limit the maximum permissible tripping current to 30 amperes. These coils will carry 2.5 amperes continuously.

RECEIVING, HANDLING AND STORAGE

These relays, when not included as a part of a control panel will be shipped in cartons designed to protect them against damage. Immediately upon receipt of a relay, examine it for any damage sustained in transit. If injury or damage resulting from rough handling is evident, file a damage claim at once with the transportation company and promptly notify the nearest General Electric Apparatus Sales Office.

Reasonable care should be exercised in un-

CONTACTS

The current-closing rating of the contacts is 30 amperes. The current-carrying rating is limited by the rating of the target and seal-in coils, since they are connected in series with the contact circuit.

BURDENS

Circuit	Volts	Amps.	Cycles	VA	Watts
3-4	-	5	60	39.3	18.6
5-6	-	5	60	17.1	17.0
7-8	120	-	60	37.8	30.8
3-4	-	5	50	32.8	15.5
5-6	-	5	50	14.3	14.2
7-8	120	-	50	31.5	29.0

Capacitive burden calculated for 120V, from measurements at minimum impedance.

packing the relay in order that none of the parts are injured or the adjustments disturbed.

If the relays are not to be installed immediately, they should be stored in their original cartons in a place that is free from moisture, dust and metallic chips. Foreign matter collected on the outside of the case may find its way inside when the cover is removed and cause trouble in the operation of the relay.

DESCRIPTION**CASE**

The case is suitable for either surface or semiflush panel mounting and an assortment of hardware is provided for either type. The cover attaches to the case and also carries the target reset mechanism. Each cover screw has provision for a sealing wire.

The case has studs or screw connections at both ends for the external connections. The electrical connections between the relay units and the case studs are made through spring backed contact fingers mounted in stationary molded inner and outer blocks between which nest removable connecting plugs which complete the circuits. The outer blocks, attached to the case, carry the studs for the external connections, and the inner blocks carry the terminals for the internal connections.

The relay mechanism is mounted in a steel framework called the cradle and is a complete unit with all leads being terminated at the inner blocks. This cradle is held firmly in the case with a latch at the top and the bottom and by a guide pin at the back of the case. The case and cradle are so constructed that the relay cannot be inserted in the case upside down. The connecting plugs, besides making the electrical connections between the blocks of the cradle and case, also lock the latches in place. The cover, which is fastened to the case by thumbscrews, holds the connecting plugs in place.

To draw out the relay unit the cover is first removed, and the plugs are pulled out. Shorting bars are provided in the case to short the current transformer circuits. The latches are then released, and the relay unit can be easily drawn out.

A separate testing plug can be inserted in place of either connecting plug to test the relay on the panel either from its own source of current and voltage, or from other sources. Or, the relay unit can be drawn out and replaced by another which has been tested in the laboratory.

**DIRECTIONAL UNITS
(GD1 AND GD2)**

The directional units are of the induction-cylinder construction. The principle by which torque is developed is the same as that employed in an induction disk relay with a watt-hour meter element, though in arrangement of parts these units are more like split-phase induction motors.

The stator of one of these units has eight laminated magnetic poles projecting inward and arranged symmetrically around a central magnetic core. The poles are fitted with current and potential coils. Three of the corner coils are connected internally to form a single circuit for current polarizing. Each of these coils has two windings, one of which carries the polarizing current. The other winding is connected in series with the corresponding winding of each of the other two coils and with a capacitor. The resultant flux from these coils is shifted

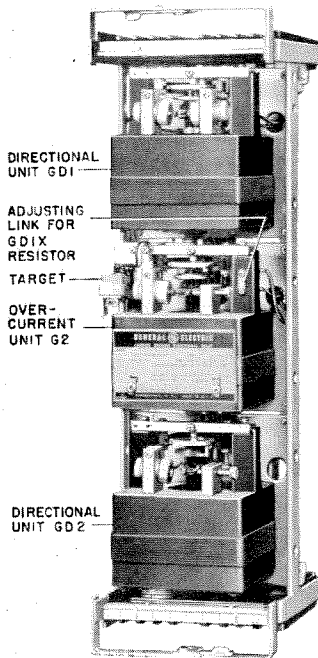

Fig. 5 Type CKPG11A Relay, Unit In Cradle (Front View)

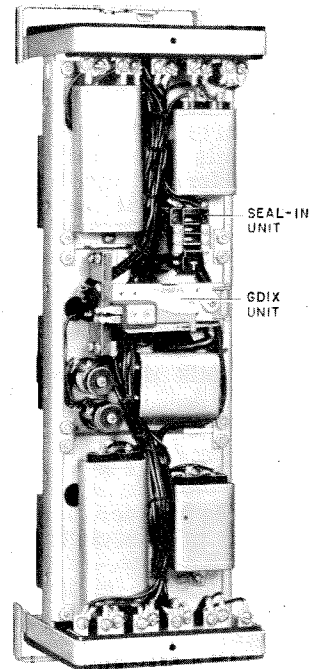

Fig. 6 Type CKPG11A Relay, unit In Cradle (Rear View)

in phase with respect to the operating circuit flux. The fourth corner coil is a potential coil for potential polarizing. The four side coils are connected together to form the operating-current circuit.

In the annular air gap between the poles and central core is the cylindrical cup-like part of the aluminum rotor which turns freely in the gap. The rotor shaft is supported at the bottom by a steel pivot which rotates against a jewel bearing located in the core. The jewel is spring-mounted to protect it from shock. The upper end of the shaft is held in place by a polished steel pivot which projects downward through a bronze guide bearing mounted in the end of the shaft. The shaft carries the movable contact arm through which the contact circuits are completed.

This type of operating unit construction provides higher torque and lower inertia of moving parts than the induction disk construction, and makes this relay faster and more sensitive.

OVERCURRENT UNIT (G2)

The overcurrent unit is also of the induction-cylinder construction and is similar to the directional units described above. It differs only in coil turns and connections. The four corner coils consist of two windings. The inner winding has a large number of turns of fine wire and the outer layer has a few turns of heavy wire. The inner windings are connected in series with a capacitor to form a

phase shifting circuit. The outer current windings are connected in series internally, and into the operating current circuit externally. The four side coils have single windings which are similarly connected into the operating current circuit.

CONTACTS

The silver-to-silver contacts are constructed with a non-bounce feature to insure a positive circuit closure. Fig. 7 shows the arrangement of the contact mechanism. The stationary contact (G) is mounted on a flat spiral spring (F) which is spaced from a thin diaphragm (C) by a washer (D). The cap (E) holds these in place on a slightly inclined tube (A) which contains a close fitting stainless steel ball (B). The energy of the moving contact is transferred to the spring and steel ball with the result that there is little or no rebound or vibration of the closing contacts.

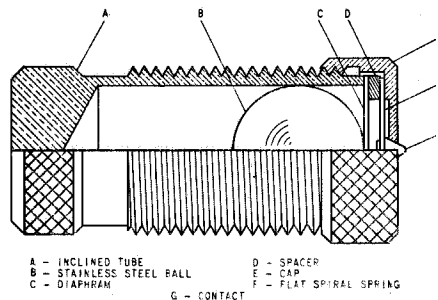

Fig. 7 Stationary Contact Assembly

Fig. 5 (8013362)
 Fig. 6 (8013361)

Fig. 7 (K-6077069)

Fig. 8 (K-6556597)

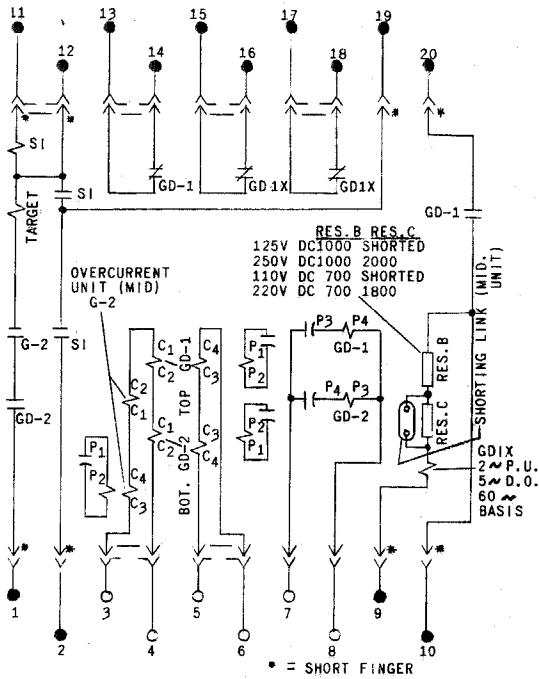

Fig. 8 Internal Connections for Type CKPG11A Relay

The moving contacts are supported on a molded plastic arm which is attached to the rotor shaft. The arm is held from rotating freely by a control spring. This spring maintains a torque in the direction to hold the left contacts open by a magnitude which determines the pickup of the unit.

The GD1 unit has both circuit-opening and circuit-closing contacts, while the G2 and GD2 units have only circuit-closing contacts. The contact arms of the G2 and GD2 units rest against backstops in a neutral position.

AUXILIARY UNIT (GD1X)

The auxiliary relay unit is a telephone-type relay with time delay features. A copper slug on the armature end of the core delays the flux buildup and consequently the relay pickup. Dropout is similarly delayed. Two normally-closed contacts of the unit are brought out separately to studs for

Fig. 9 (3624595)

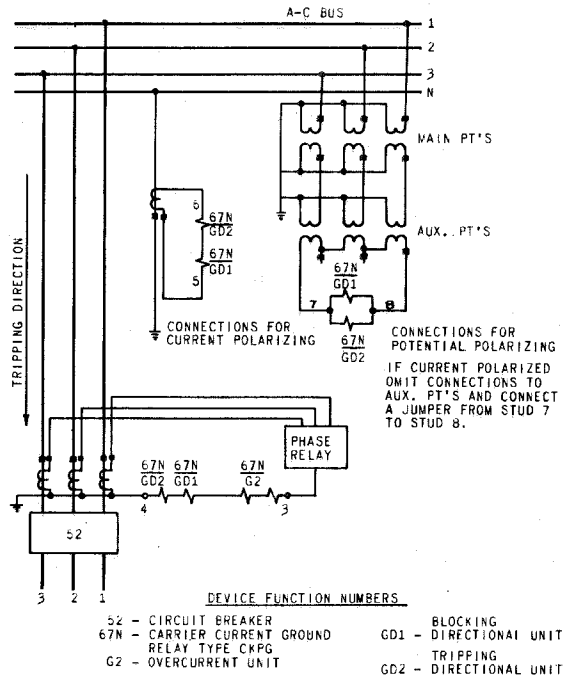

Fig. 9 External Connections for Type CKPG11A Relay

external circuit control (studs 15 and 16 and studs 17 and 18, Fig. 8). Operation of GD1X is described under OPERATING CHARACTERISTICS.

Two resistors in series with the relay coil determine the rating of the circuit. One of the resistors may be shorted by a link located on the right-hand upright of the molded upper-bearing support of the middle cup unit. Inserting the link across the two studs that are provided lowers the d-c rating of the control circuit by 50 per cent.

SEAL-IN UNIT (SI)

The seal-in unit is picked up by the flow of trip current through the seal-in coil. Provision is made for energizing the coil through the tripping contacts of a backup relay (stud 12). Contact arrangement provides for completing the circuit to two electrically separate points (studs 2 and 19) through the seal-in coil from a third point (stud 11).

INSTALLATION

LOCATION

The location should be clean and dry, free from dust and excessive vibration, and well lighted to facilitate inspection and testing.

MOUNTING

The relay should be mounted on a vertical surface. The outline and panel drilling diagram is shown in Fig. 11.

CONNECTIONS

Internal and external connection diagrams are shown in Figs. 8 and 9, respectively. External connections of the contact circuits depend on the specific application of the relay. Typical circuits may be found in carrier current pilot relaying instruction books.

One of the mounting studs or screws should be

permanently grounded by a conductor not less than No. 12 B & S gage copper wire or its equivalent.

INSPECTION

At the time of installation, the relay should be inspected for tarnished contacts, loose screws, or other imperfections. If any trouble is found it should be corrected in the manner described under MAINTENANCE.

INITIAL ADJUSTMENTS

CALIBRATION SETTING

The relays are shipped from the factory with minimum recommended pick-up calibrations. It may be necessary to readjust pickup to a higher value if required by the particular application. In any case it is important to maintain the proper difference between the product pickup of the GD1 and GD2 units which must co-ordinate (see APPLICATION). By using the test connections shown in Fig. 10, each of the units should be adjusted for the desired pick-up level. If calibration of the directional units is made using potential polarization, the actual product, EX1, used in the adjustment should be twice the desired pick-up value. This is necessary since the test connections provide in-phase

current and voltage, whereas maximum torque occurs with a 60-degree lagging power factor.

Pick-up should be set using a voltage across the potential coil circuit between 5 and 30 volts. The pick-up setting is made by adjusting the restraining torque of the upper control spring (see Fig. 5). To do this, loosen the hexagonal-head locking screw located at the rear of the spiral spring assembly. Then slip the adjusting ring (to which the spiral spring is attached) in the ring guide in a direction which will cause the left contacts barely to close at the pick-up level chosen. *Next, raise the voltage to 80 volts and check pickup. The product pickup should be approximately the same as when checked at the lower voltage. If the product pickup is off adjustment, the core may be rotated slightly to get approximately the same product pickup as at the lower voltage.

AUXILIARY CIRCUIT RATING

At the time of installation the shorting link position should be checked. Incorrect location of this link will result in either damage to the relay, or failure to operate properly. For the higher of the dual voltage ratings of the auxiliary circuit, the link should be in a position in which it does not short circuit the series resistor. This may easily be done by removing one of the screws and rotating the link.

MAINTENANCE

ADJUSTMENTS

The relays are adjusted at the factory and it is advisable not to disturb the adjustments. If, for any reason, they have been disturbed, the following points should be observed in restoring them.

CONTACT GAP

The contact gap may be adjusted by loosening slightly the screw at the front of the contact block (see Fig. 5). The screw should be loose enough only to allow the contact barrel to rotate in its sleeve. Adjust the right contact barrel (GD1 unit) and stop screws (G2 and GD2 units) so that the moving contact arm is held in a neutral position, i.e., with the arm pointing directly forward. Then rotate the left stationary-contact barrel in a direction which will close the contact gap. With the left contacts just closed, back off the left contact barrel 2/3 turn to obtain approximately 0.020 inch contact gap. Tighten the screws which secure the barrels and the locknuts which clamp the stop screws.

Following contact gap adjustment it is necessary that pick-up tests be performed as outlined in the section under INSTALLATION.

CLUTCH

The clutch adjustment is made by means of the screw on the right side of the moving contact arm. To change the clutch adjustment, loosen the locknut and tighten the screw to increase the current at which the clutch slips, or back the screw out to decrease the current at which the clutch slips. Be sure to tighten the locknut after the adjustment is made. The clutch should be adjusted to slip at the values of current listed in the following table using the test connection shown in Fig. 10 for current polarization (operating and current polarizing circuits in series).

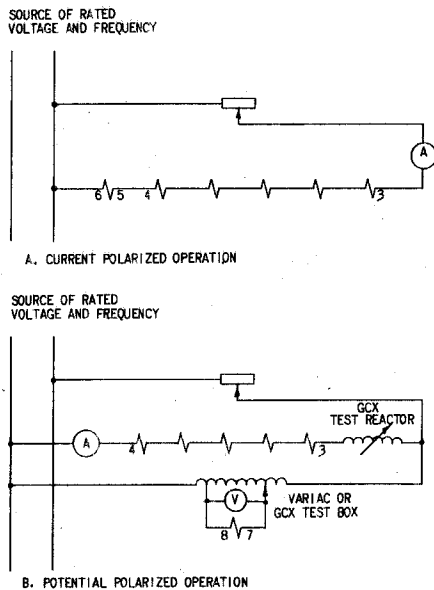

THESE CONNECTIONS PRODUCE TORQUE TENDING TO CLOSE THE NORMALLY OPEN CONTACTS OF ALL UNITS. REVERSING THE CONNECTIONS OF STUDS 5 AND 6 OR 7 AND 8 WILL REVERSE THE TORQUE OF THE GD UNIT ONLY.

* Fig. 10 Test Connections for Type CKPG Relay

* Denotes change from superseded issue.

Unit	Rating Amps.	Clutch Slips Amps
GD1	0.5-2.0	3.5-5
G2	0.5-2.0	3.5-5
GD2	0.5-2.0	3.5-5

TIME TESTS

For proper co-ordination of relays at different terminals of the line it may be desirable to know the pick-up time of the units. For this purpose it is necessary to use an oscillograph or an electronic timer because the speed of the relay is such that a mechanical timer is unsatisfactory.

Typical operating time characteristic curves are shown in Figs. 2 and 3. The electrical connections shown in Fig. 10 may be used for these tests. However, since maximum torque of the directional unit when potential polarized occurs with a lagging phase angle of 60 degrees, only one-half of this torque will be produced by the in-phase test connections shown. Hence the EXI product of the tests should be divided by 2 before comparison of the times with the curve of Fig. 3.

In order that the transient blocking be effective, it is necessary that the telephone relay unit be in proper adjustment. Only in rare circumstances should it be necessary to change any adjustment of this unit. The normally closed contact opening (pickup) time must be 2 cycles (60 cycle basis), and the normally closed contact closing (dropout) time must be 5 cycles.

CUP AND STATOR

If it is necessary to remove the rotor from the unit, the following procedure should be observed. (Refer to Figs. 5 and 6).

The lacing which binds the leads together should be cut, and the leads to the contact structure should be removed and tagged for identification to facilitate reconnecting. Then remove the four corner screws which fasten the mounting plate to the cradle. Also remove the upper of the three flat-head screws which fasten the cup unit to the mounting plate. Tilt the mounting plate forward and remove the four corner screws which hold the contact head to the stator. Avoid any disturbance to the top bearing support. The entire top structure with the rotor can then be lifted away from the stator to give access to the assembly. Care should be taken not to strain the leads entering the back of the stator. Unless there is reason for removing the stator from the cradle, these leads need not be disconnected.

To remove the shaft and rotor from the contact head assembly, the spring clip at the top of the shaft must be pulled out, and the clutch adjusting screw and spring taken out of the molded contact arm.

The rotor should be handled carefully while it is out of the unit, and the stator should be protected to keep it free from dust or metallic particles.

In reassembly, the rotor will go into the air gap easily if the parts are held in the proper position. The dowel pins will serve to restore the original alignment.

A test of pickup and of clutch adjustment is necessary after a unit has been disassembled and reassembled. A check should also be made of the contact circuits to insure correct connections.

SHAFT AND BEARINGS

The lower jewel screw can be removed from the unit by means of an offset screw driver or an end wrench. The jewel may be tested for cracks by exploring its surface with the point of a fine needle. If it is necessary to replace the jewel, a new pivot should be screwed into the bottom of the shaft at the same time.

The lower jewel bearing should be screwed all the way in until its head engages the end of the threaded core. The upper bearing should be adjusted to allow about 1/64 inch end play of the shaft.

To check the clearance between the iron core and the inside of the rotor cup, press down on the contact arm near the shaft and thereby depress the spring mounted jewel until the cup strikes the iron. The shaft and cup should move about 1/16 inch.

CONTACT ASSEMBLY

To change the stationary contact mounting spring remove the contact barrel and sleeve as a complete unit after loosening the screw at the front of the contact block. Unscrew the cap (E Fig. 7). The contact and its flat spiral mounting spring may then be removed. Correct adjustment of the spring is such as to provide a 0.004 to 0.009 inch movement of the stationary contact (G) from the point of contact closure to the point at which it touches the thin diaphragm (C).

The moving contact may be removed by loosening the screw which secures it to the contact arm and sliding it from under the screw head.

CONTACT CLEANING

For cleaning fine silver contacts, a flexible burnishing tool should be used. This consists of a flexible strip of metal with an etched roughened surface, resembling in effect a superfine file. The polishing action is so delicate that no scratches are left, yet corroded material will be removed thoroughly and rapidly. The flexibility of the tool insures the cleaning of the actual points of contact.

Fine silver contacts should not be cleaned with knives, files, or abrasive paper or cloth. Knives or files may leave scratches which increase arcing and deterioration of the contacts. Abrasive paper or cloth may leave minute particles of insulating abrasive material in the contacts and thus prevent closing.

The burnishing tool described is included in the standard relay tool kit obtainable from the factory.

RENEWAL PARTS

It is recommended that sufficient quantities of renewal parts be carried in stock to enable the prompt replacement of any that are worn, broken, or damaged.

When ordering renewal parts, address the

nearest Sales Office of the General Electric Company, specify quantity required, name of part wanted, and give complete nameplate data, including serial number. If possible, give the General Electric Company requisition number on which the relay was furnished.

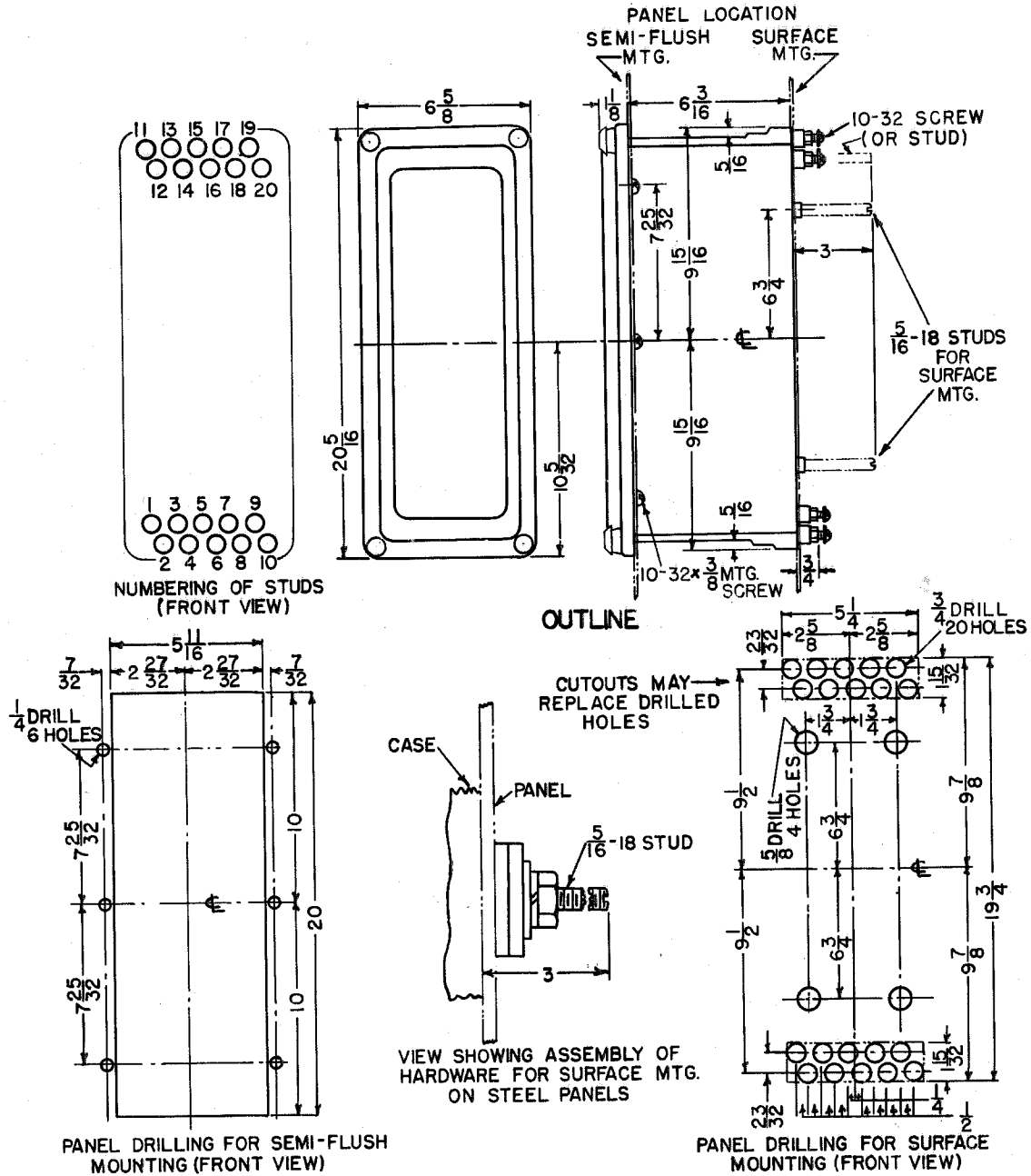

Fig. 11 (K-6209276)

Fig. 11 Outline and Panel Drilling Dimensions for Type CKPG Relay