

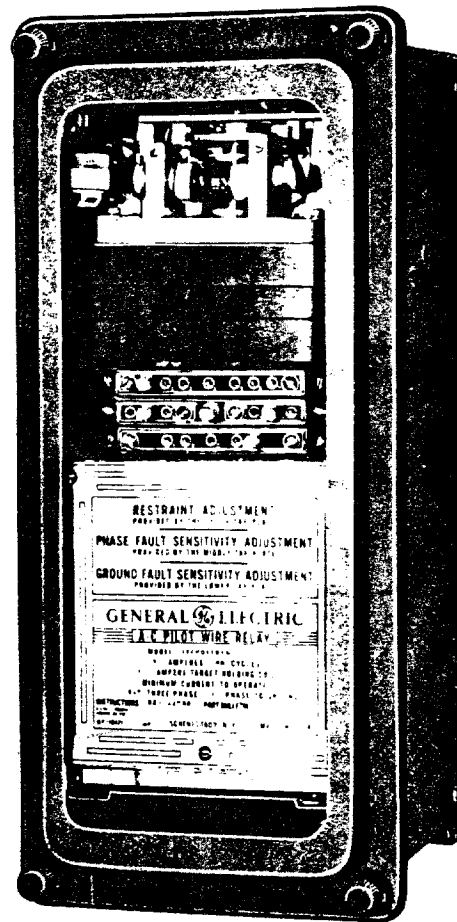

INSTRUCTIONS

GEH-1811C
Supersedes Geh-1811B

A-C PILOT WIRE RELAY



Type CPD11D

GENERAL  ELECTRIC

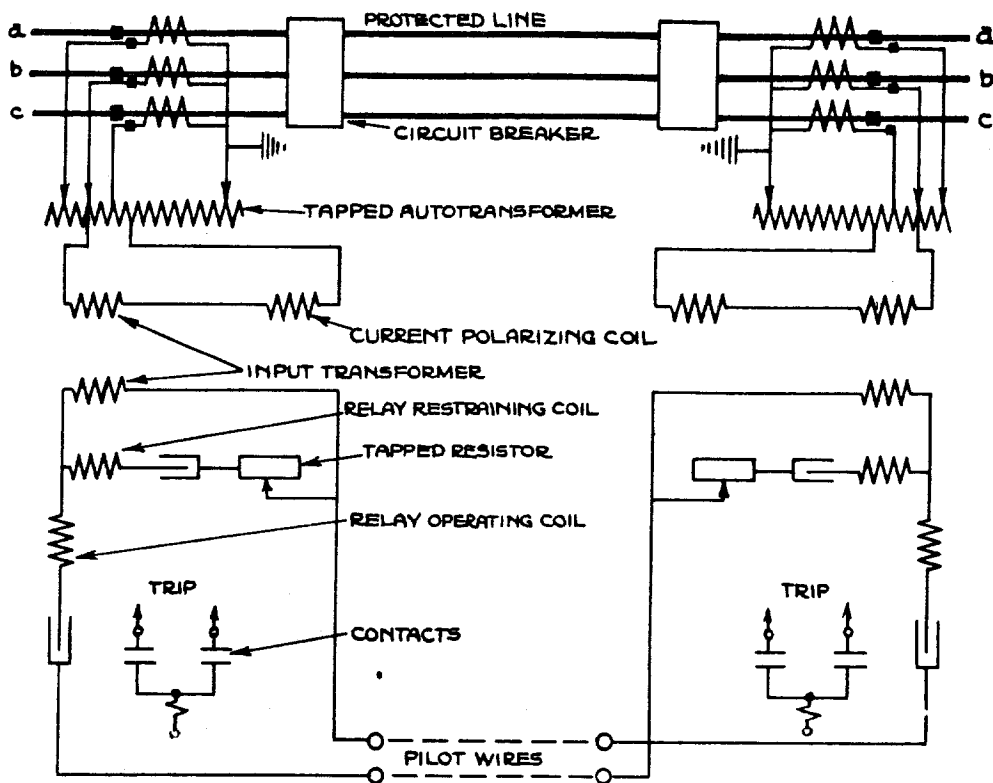

Fig. 1 Schematic Diagram for the Type CPD Relays

Cover (8007372)

Fig. 1 (K-6154803)

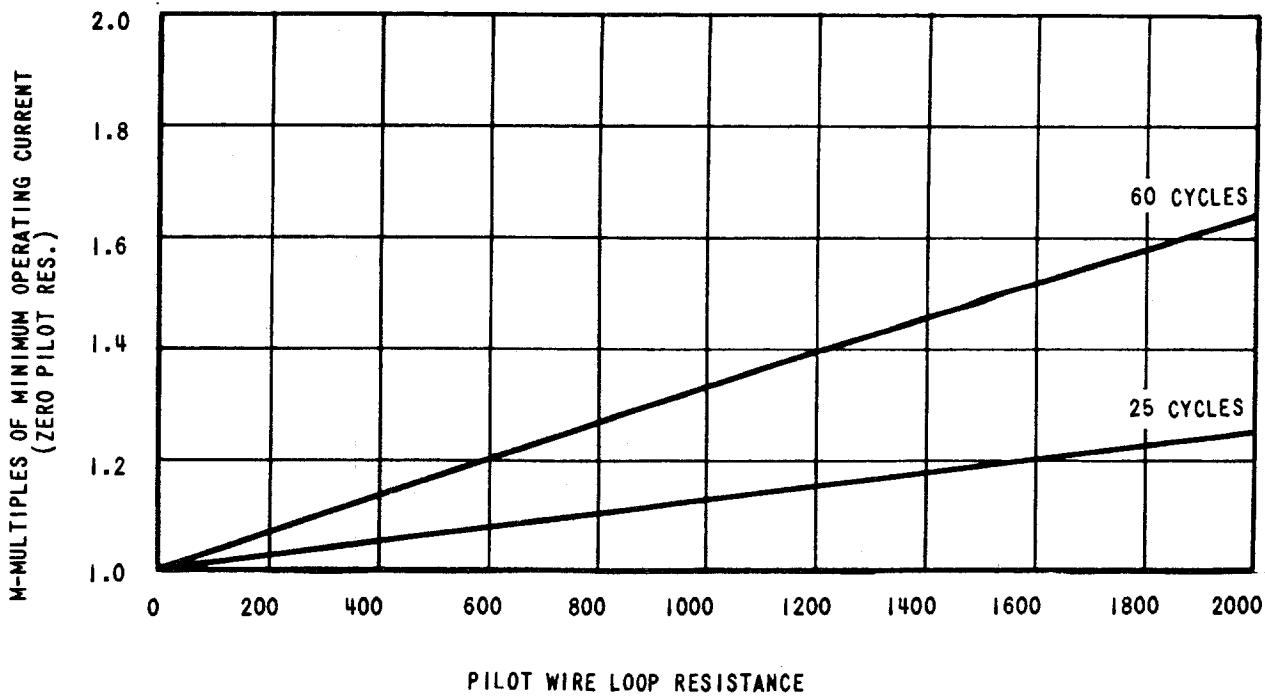

Fig. 2 Effect of Pilot Wire Resistance on Minimum Operating Current of the Type CPD Relay

Fig. 2 (M-6082112)

A-C PILOT WIRE RELAY TYPE CPD11D

INTRODUCTION

The Type CPD11D relay is a single-element pilot-wire relay. Two of these relays, one at each end of a 3-phase line and a 2-wire a-c pilot-wire channel, provide protection for both phase and ground faults over the entire length of the line.

The CPD relays are primarily for use on lines which have but two terminals (no taps). Applications involving multi-terminal lines should be referred to Relay Marketing section, Philadelphia Works for study and recommendations.

The auxiliary equipment ordinarily supplied with each relay consists of an insulating transformer, a volt-meter, and an SB-1 test switch.

DESCRIPTION AND OPERATION

RELAY DESCRIPTION

The relay consists of the following elements:

<u>Element</u>	<u>Purpose</u>
1. Relay element.	To trip or block according to fault location.
2. Tapped auto-transformer	To obtain a single current to replace currents in phases and ground.
3. Input transformer.	To obtain a pilot-wire input voltage with minimum volt-ampere burden.
4. Tapped resistor.	To adjust the restraint in accordance with the length of the pilot wire.
5. Two capacitors.	To obtain desired phase angle relationships.

The relay element is an induction-cylinder directional relay, its operating principle being substantially the same as that of the familiar watt-hour meter. The arrangement of parts, however, is more like an induction motor, there being eight magnetic poles projecting inward and arranged symmetrically around a central magnetic core. The rotor is a cup-like aluminum punching, the cylindrical part of which rotates in the air gap between the outer poles and the central core.

The stator has eight coils, four of which are current polarizing coils. The remaining four coils, in conjunction with the polarizing current coils, provide operating and restraining torques.

The contact assembly consists of two normally open contacts for tripping two circuit breakers.

The common connection between the contacts contains a holding coil and target.

All settings are made by means of three tap blocks located on top of the nameplate at the front of the relay. The upper tap block, which is connected to the tapped resistor, provides the restraint adjustment in accordance with the pilot wire resistance. The middle tap block provides adjustment of phase fault sensitivity, or permits the use of current transformers of different ratio. The lower tap block provides the sensitivity setting on ground faults.

RELAY OPERATION

Two CPD11D relays operate in conjunction, as shown in Fig. 1, to provide high-speed differential protection. The tapped autotransformer transforms three-phase and ground currents into a single-phase current, which energizes the primary of the input transformer and the current polarizing coils of the relay element. The secondary voltage of the input transformer leads its input current by 90 degrees because the iron core has an air gap. This voltage is applied to the relay restraining circuit and to the pilot wires through the relay operating coils. The operating and restraining coil circuits are tuned to unity power factor, so the currents in these circuits are at maximum torque angle with reference to the polarizing current.

On a through fault, opposing voltages will be produced at the two ends of the pilot wire and no operating current will flow except that due to difference in current transformer characteristics and minor differences in the relays. At the same time, current in the restraining circuit will overcome any extraneous operating torque.

On an internal fault, the voltages at the two ends of the pilot wire will be additive, thereby causing a relatively large operating current to flow. Thus, an operating torque will be produced which will be large relative to the restraining torque and the relay will trip.

The output current of the tapped auto-transformer is proportional to the vector difference of the currents in phases a and c, plus the residual current times a constant dependent upon the relation between the turns in the residual and phase windings, or

$$I_R = I_a - I_c + KI_g$$

where I_R = output of tapped autotransformer
 I_g = residual current
 K = constant relating turns in phase ground windings.

These instructions do not purport to cover all details or variations in equipment nor to provide for every possible contingency to be met in connection with installation, operation or maintenance. Should further information be desired or should particular problems arise which are not covered sufficiently for the purchaser's purposes, the matter should be referred to the General Electric Company.

To the extent required the products described herein meet applicable ANSI, IEEE and NEMA standards; but no such assurance is given with respect to local codes and ordinances because they vary greatly.

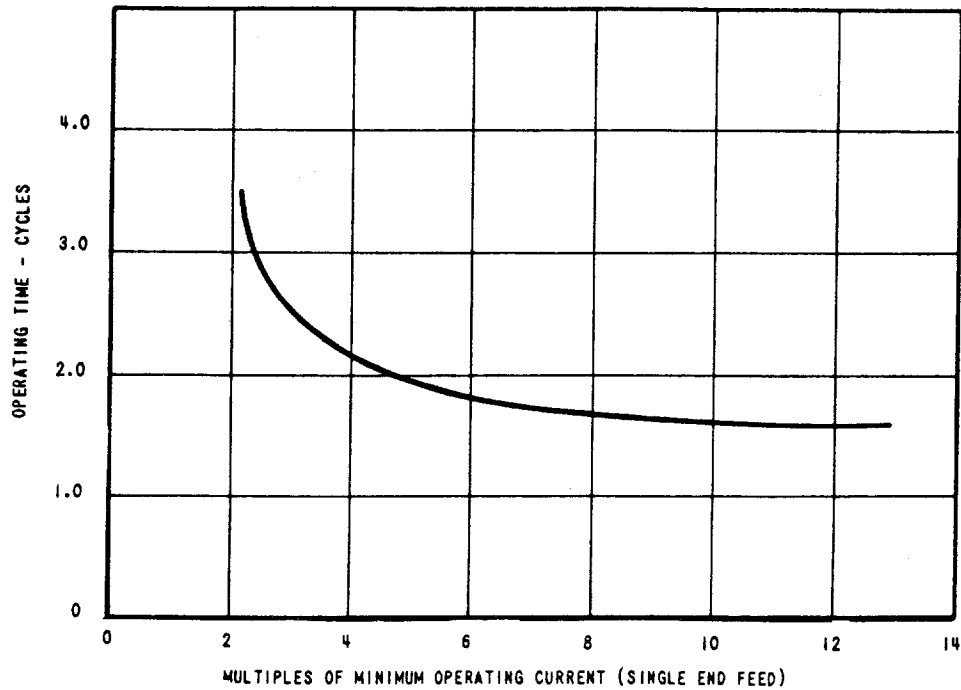

Fig. 3 Average Operating Time for the Type CPD11D 60 Cycle Relay

Fig. 3 (K-6400484)

OPERATING CHARACTERISTICS

MINIMUM OPERATING CURRENT

Phase-to-ground Faults

Phase C-(other phases have slightly lower pick-up) - A tap plate is provided to adjust the ground fault sensitivity; the taps are marked A, B, C, D and E. They provide pickup at the following minimum current transformer secondary currents:

Tap	A	B	C	D	E
Min. Oper. Cur.	3.5	2.8	2.0	1.4	1.0

Phase Faults

A tap block with two tap plates is provided to adjust the phase fault sensitivity; or to permit the use of current transformers differing in the ratio of 2 to 1, 3 to 1, or 4 to 3. Minimum pickup values are as follows:

THREE-PHASE FAULTS

Tap	2.7	4	5.4
Pick-up Current	2.7	4	5.4

PHASE-TO-PHASE FAULTS

Tap	2.7	4	5.4
Phases a-b and b-c	4.7	7	9.4
Phase c-a	2.35	3.5	4.7

NOTE: The above pick-up values are based on single-end feed with zero pilot resistance and maximum restraint (tap #1 on the upper block). The minimum pick-up will be higher as the pilot wire resistance increases. See Fig. 2. Also, if two circuit breakers are to be tripped it is advisable to allow for about 25 per cent increase in pick-up to assure closure of both contacts. If only one circuit breaker is to be tripped, it is recommended that the two tripping contacts be connected in parallel.

AVERAGE OPERATING TIME

This curve (Fig. 3) is based upon single-end feed. Operating times will be slightly less for double-end feed, e.g., with substantially the same grounding and generation at each end the operating times on the curve will be reached at approximately 70 percent of the current indicated by the curve.

EXTERNAL FAULTS

The slope of the relay without the tapped auto-transformer is approximately 50 per cent (differential current in per cent of smaller of two restraining currents). However, saturation of the tapped autotransformer causes the slope to be greater than 50 per cent and to become relatively higher at the higher currents. The operating-restraining curve is shown in Fig. 4 for 60 cycle relays, Fig. 5 for 25 cycle relays, and Fig. 6 for 50 cycle relays.

Fig. 4 (K-6400483)

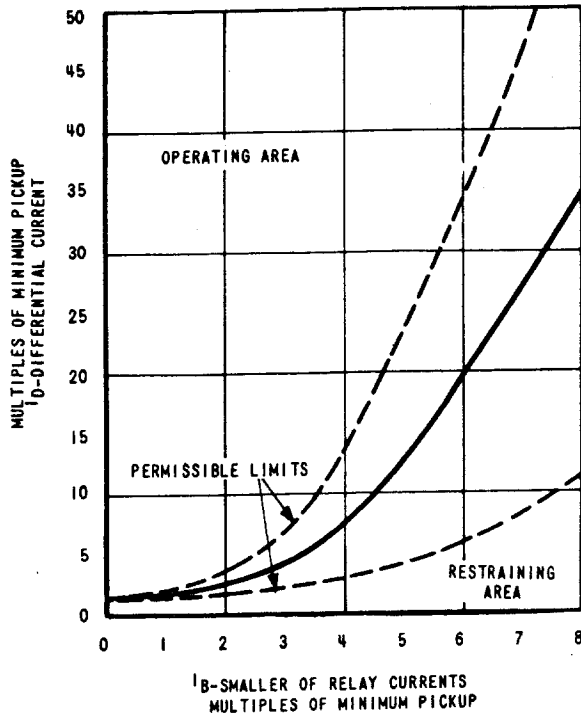

Fig. 4 Typical Operating-Restraining Curve for the 60 Cycle Type CPD11D Relay with Currents in Phase

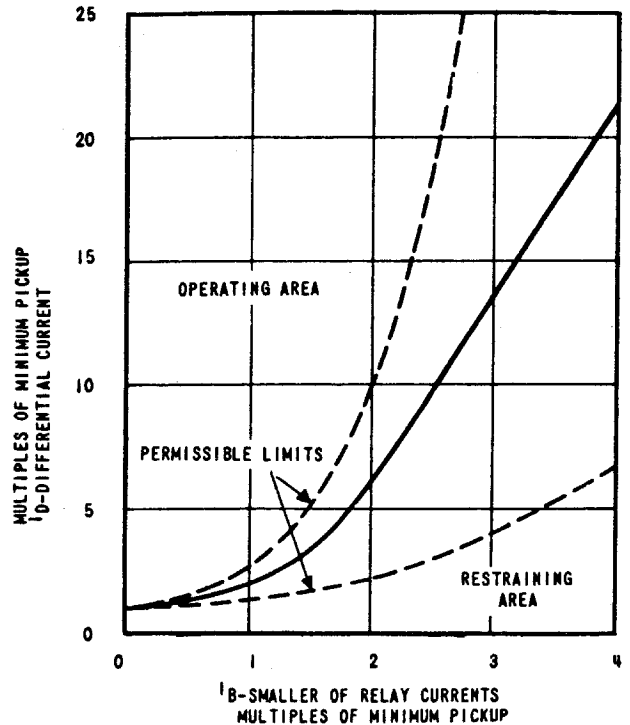

Fig. 5 Typical Operating-Restraining Curve for the 25 Cycle Type CPD11D Relay with Currents in Phase

RATINGS

Type CPD11D relays are rated 5 amperes and may be obtained in 60, 50, or 25 cycle frequency ratings and with either 1.0 ampere or 0.2 ampere holding and target coil ratings.

TARGET COILS AND HOLDING COILS

There are two ratings of these coils available. The choice between them depends on the current taken by the tripping circuit.

The 0.2 ampere coil is for use with trip coils that operate on currents ranging from 0.2 to 1.0 ampere at the minimum control voltage. If this coil is used with trip coils that take 1.0 ampere, or more, there is a possibility that the 15 ohm resistance of each coil will reduce the tripping current to so low a value that the breakers will not be tripped.

The 1.0 ampere coil should be used with trip coils that take 1.0 ampere or more at the minimum control voltage provided the tripping current does not exceed 30 amperes. If the tripping current exceeds 30 amperes an auxiliary relay must be

Fig. 5 (K-6400486)

Fig. 6 (K-6400485)

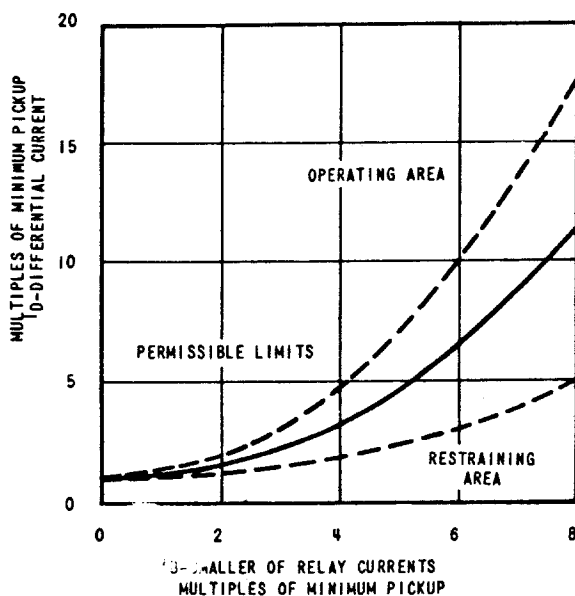

Fig. 6 Typical Operating-Restraining Curve for the 50 Cycle Type CPD11D Relay with Currents in Phase

GEH-1811 Pilot Wire Relay Type CPD11D

used to control the trip coil circuit, the connections being such that the tripping current does not pass through the contacts, target coils or holding coils of the Type CPD relays.

When it is desirable to adopt one type of relay as standard to be used anywhere on a system, relays with the 1.0 ampere target and holding coil should be chosen. These relays should also be used where it is impossible to obtain trip-coil data, but attention is called to the fact that the target may not operate if used in connection with trip coils taking less than 1.0 ampere.

The ratings of the two forms of target and holding coils are as follows:

Function	Amperes AC or DC	
	1.0 Amp Target Coil and Holding Coil (0.3 ohm for both coils)	0.2 Amp Target Coil and Holding Coil (15 ohms for both coils)
Carry for Tripping Duty	30	5
Carry Continuously	4	0.4

BURDEN CALCULATIONS

Using saturation curve Fig. 7, the single-phase-to ground and the three phase burden of the 60 cycle forms of relay 12CPD11D can be calculated. Table I shows the percentage of total mixing transformer turns between various relay terminals for the different combinations of taps.

TABLE I

Taps		Percentage of Total Mixing Transformer Turns			
Phase	Ground	P3	P4	P5	Pphase
2.7	A	50	35	20	15
2.7	B	55	40	25	15
2.7	C	65	50	35	15
2.7	D	80	65	50	15
2.7	E	100	85	70	15
4.0	A	40	30	20	10
4.0	B	45	35	25	10
4.0	C	55	45	35	10
4.0	D	70	60	50	10
4.0	E	90	80	70	10
5.4	A	35	27.5	20	7.5
5.4	B	40	32.5	25	7.5
5.4	C	50	42.5	35	7.5
5.4	D	65	57.5	50	7.5
5.4	E	85	77.5	70	7.5

where:

P3 = Turns between terminals 3 and 6 in % of total turns

P4 = Turns between terminals 4 and 6 in % of total turns

P5 = Turns between terminals 5 and 6 in % of total turns

Pphase = Turns between terminals 3 and 4 or 4 and 5 in % of total turns.

A. SINGLE-PHASE-TO-GROUND BURDEN

For a single phase to ground fault the burden imposed on the CT in the faulted phase will be the voltage from the terminal connected to this CT to terminal 6. Multiply the number of turns (P times total turns of mixing transformer) between the terminals in question by the CT secondary current and read the corresponding volts per turn for these ampere turns from saturation curve Fig. 7. Multiply the volts per turn by the number of turns between the faulted section.

EXAMPLE A.

With the CT connected to terminal 3 and the combination of 4.0 phase and C ground taps, the burden for a single-phase-to-ground fault of 5 amperes will be as follows:

$$\text{Total mixing transformer turns} = N_T = 240$$

$$\begin{aligned} \text{Turns between terminals 3 and 6} &= N_3 = N_T P_3 \\ &= 240 \times .55 = 132 \end{aligned}$$

$$\text{Ampere turns} = \text{current} \times N_3 = 5 \times 132 = 660$$

$$\begin{aligned} \text{Volts per turn @ 660 ampere turns from Fig. 7} \\ &= 0.12 \end{aligned}$$

$$\text{Volts} = \text{volts per turns} \times N_3 = 0.12 \times 132 = 15.82$$

$$\text{Volt-amperes} = 15.82 \times 5 = 79.1$$

The CT connected to terminal 3 will have a burden of 79.1 volt-amperes for a single-phase-to-ground fault of 5 amperes with a combination of 4.0 phase and C ground taps.

B. THREE PHASE BURDEN

For balanced three phase conditions the burden imposed on a particular CT will be the voltage from the terminal connected to this CT to terminal 6. The effective exciting ampere-turns will be $\sqrt{3}$ Nphase I where Nphase is the turns between terminals 3 and 4, and I is the magnitude of the current in one phase.

Determine the effective exciting ampere turns and find the corresponding volts per turn from Fig. 7. Multiply this volts per turn by the turns between the terminal connected to the CT in question and terminal 6.

EXAMPLE B.

For the same settings as in example A and balanced three phase currents of 5 amperes, the burden will be as follows:

$$\text{Total Mixing transformer turns} = N_T = 240$$

$$\text{Turns between terminals 3 and 4} = N_{\text{phase}}$$

$$= N_T \times P_{\text{phase}} = 240 \times .10 = 24$$

$$\begin{aligned} \text{Effective exciting ampere turns} &= \sqrt{3} N_{\text{phase}} I \\ &= \sqrt{3} \times 24 \times 5 = 208 \end{aligned}$$

Fig. 7 (403A106)

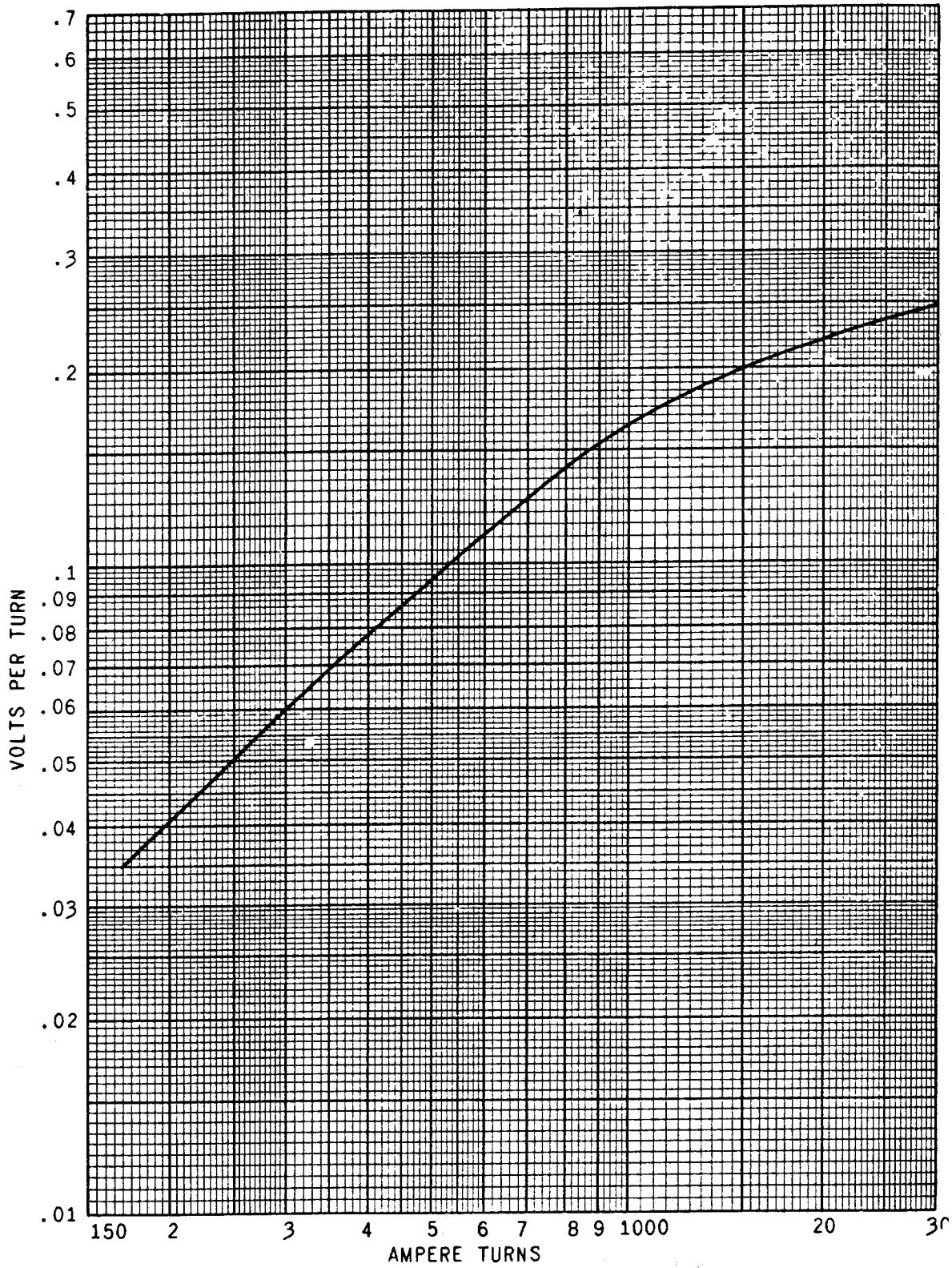

Fig. 7 Saturation Curve for Model 12CPD11DIA Relay

Volts per turn @ 208 ampere turns from Fig. 7.
= 0.043
Turns between terminals 3 and 6 = $N_3 = N_T P_3 =$
 $240 \times .55 = 132$
Volts = $N_3 \times$ volts per turn = $132 \times 0.043 = 5.67$
Volt-amperes = $5.67 \times 5 = 28.35$

The CT connected to terminal 3 will have a burden of 28.35 volt-amperes for balanced three-phase current of 5 amperes with a combination of 4.0 phase and C ground taps.

RECEIVING, HANDLING AND STORAGE

These relays, when not included as a part of a control panel will be shipped in cartons designed to protect them against damage. Immediately upon receipt of a relay, examine it for any damage sustained in transit. If injury or damage resulting from rough handling is evident, file a damage claim at once with the transportation company and promptly notify the nearest General Electric Apparatus Sales Office.

Reasonable care should be exercised in un-

packing the relay in order that none of the parts are injured or the adjustments disturbed.

If the relays are not to be installed immediately, they should be stored in their original cartons in a place that is free from moisture, dust and metallic chips. Foreign matter collected on the outside of the case may find its way inside when the cover is removed and cause trouble in the operation of the relay.

INSTALLATION

LOCATION

The location should be clean and dry, free from dust and excessive vibration, and well lighted to facilitate inspection and testing.

MOUNTING

The relay should be mounted on a vertical surface. The outline and panel drilling diagram is shown in Fig. 24. Outlines of the insulating transformer, voltmeter and switch are shown in Figs. 21, 22, and 23.

CONNECTIONS

The internal connection diagram is shown in Fig. 9 and external connections are shown in Fig. 8.

PILOT WIRES

Only two pilot wires are required. These may have a loop (two way) resistance of up to 3200 ohms, if the shunt capacitance does not exceed 1.4 mfd. For lines, where the pilot-wire resistance and capacitance exceeds these values, the application should be referred to Relay Marketing, Philadelphia Works to see if the type CPD relay can be used.

The pilot wires can be telephone wires or private lines. If private lines are used, shielded cable containing individual wires twisted in pairs is recommended.

The pilot wire current and voltage will not exceed 120 volts and 0.35 amperes rms as permitted on leased telephone lines, up to 60 times pickup for any fault.

Insulation strength should be sufficient to withstand induced voltages and difference in station

ground potentials. Insulation stress caused by induction can be reduced by the use of different routes for the power lines and pilot cable. The difference between station ground potentials is largely concentrated near the power station. If this potential difference is large it may be economical to use two different levels of cable insulation strength, using the higher level close to the stations.

The standard telephone insulating transformer supplied with the Type CPD relays is tested at 20,000 volts between the pilot-wire winding and ground, and between the pilot-wire winding and the relay winding. These transformers isolate the relays from induced voltage and the potential difference of station grounds. When there is a possibility of high potential being obtained on the pilot wires (in excess of 600 volts), the pilot-wire connections should be carried directly to the insulating transformers (and supervising relays) if used.

The induced voltage difference between wires should not be above 5 volts with low-line currents (of the order of normal full-load current). At high currents, this voltage may safely be as high as 15 volts. If the pilot-wire circuit is a twisted pair, difference in voltage of the two wires caused by induction need not be considered.

If the pilot wires are open-circuited, no operating current can flow, and consequently, the relays cannot trip.

If the pilot wires are short-circuited, the relays operate as overcurrent relays, and would trip on through faults and loads in excess of the three-phase pick-up setting. A short-circuit of the pilot-wires would permit greater operating current than normal to flow. For example, if the pilot short-circuit is near a station, the three-phase pick-up of the relay at that station would be reduced about 30 per cent. If the fault currents are sufficiently

Fig. 8 (026480' -4)

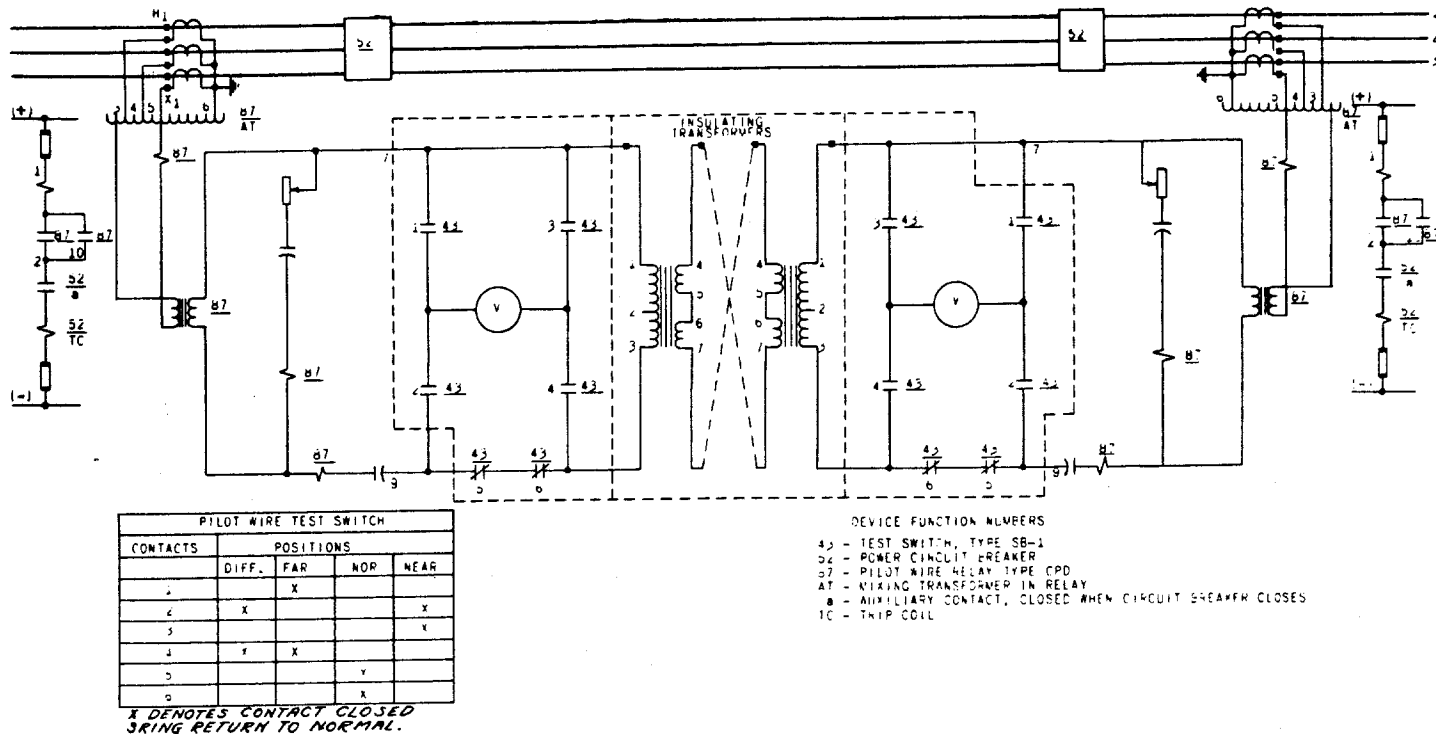

Fig. 8 Elementary Diagram of External Connections for the Type CPD11D Relay, with Insulating Transformer, Voltmeter, and Type SB-1 Test Switch

Fig. 9 (K-6209730)

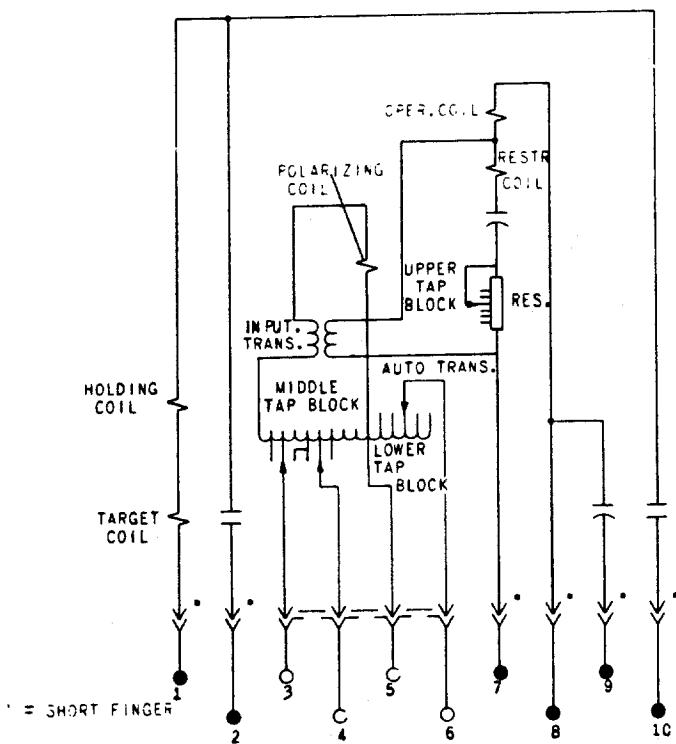

Fig. 9 Internal Connections for the Type CPD11D Relay (Front View)

high, the three-phase pick-up may be increased by adjustment of the control spring (see MINIMUM OPERATING CURRENT under LABORATORY TESTING). It must be remembered that such an adjustment raises all pick-ups in the same ratio.

CURRENT TRANSFORMERS

Since pilot wire relaying is a form of differential relaying, its proper operation depends to a large extent on the current transformers used at the two ends of the line. If the current transformers at both ends of the line are all bushing CT's or if they are all wound CT's and the CT's are of the same type, ratio, and overcurrent characteristics and if their connected burdens are not widely different, pilot wire relaying may be applied without any special calculations. In these cases, the ratio curves for the CT's at opposite ends of the line will match closely and little or no CT difference current will result even on heavy external faults.

In other cases where the ratio curves for the CT's do not match very closely, special calculations are necessary to insure that the combination will not cause false relay operation when the ratio error of the poorer CT's exceeds 20% on a maximum phase fault current. Such cases are encountered when: wound CT's are used at one end of the line with bushing CT's at the opposite end; or when the bushing or wound CT's are of different type or different overcurrent characteristics; or when the connected CT burden is excessive at one end of the line.

The use of auxiliary current transformers for ratio matching should be avoided if possible. If they are necessary, it must be realized that the over-all quality of the current transformation will only be as good as the poorer transformer whether it be the primary CT or the auxiliary CT. The internal impedance of an auxiliary CT can add appreciable burden to the main CT and affect its operation. The same general application rule should be followed; that is, if the over-all ratio error of the combination of primary and auxiliary CT does not exceed 20% at the maximum phase fault current, no special calculations need be made to apply pilot wire relaying.

In cases where the ratio mismatch of current transformers at opposite ends of the line will cause false operation of the pilot wire relaying on external faults, the best and obvious solution is to obtain more suitable current transformers. However, if this is not practical, the ratio curve of the better CT can be made to match that of the poorer CT by the addition of a resistor burden to the better CT. It is important that such a resistor burden have a one-second current rating commensurate with the maximum secondary current expected. The CPD relay has a one-second current rating of 220 amperes. If it is necessary to add resistor burdens to match CT ratio curves for phase faults, a similar neutral resistor burden should also be added to match CT ratio curves on single-phase-to-ground faults. This will eliminate the possibility of causing false relay operation on d-c transients resulting from a difference in the saturated CT characteristics.

INSTALLATION TESTS

CAUTION:

Every circuit in the drawout case has an auxiliary brush; this is the short one in the case (not on the cradle) which the connection plug or test plug should engage first. On every current circuit or other circuit with a shorting bar, make sure these auxiliary brushes are bent high enough to engage the connection plug or test plug before the main brushes in the case do, as otherwise the CT secondary circuit may be opened (where one brush touches the shorting bar) before the circuit is completed from the plug to the other main brush.

Upon installing the relay, it is necessary to know the following:

1. That the relay is in good mechanical condition. The moving parts should be very free and the spring should promptly return the contact arm when it is displaced manually from its de-energized position.

2. That the proper taps are used (see APPLICATION).

CAUTION: Before changing the current taps, the pilot-wire circuit should be opened by removing the connecting plug. This will prevent false tripping by unbalanced relay current during the change.

3. That none of the relay circuits are open.

4. That the current transformer leads go to the proper relay terminals. (See CONNECTION CHECK section).

5. That the pilot wire and insulating transformers are connected so that the voltages at the two ends normally oppose. (See CONNECTION CHECK section).

CHECK FOR OPEN RELAY CIRCUIT

With 5 amperes in terminals 3-6 and no other leads on the relay, there should be a definite restraining torque (in excess of the spring torque). Repeat with current in terminal 4-6 and with current in terminals 5-6. This checks against an open restraint circuit.

Short circuit terminals 9 and 7 and determine the minimum operating current in terminals 5 and 6. This should be approximately 0.5 to 0.7 ampere with the tap in the upper tap block set on 1, and the tap in the lower tap block set on E (See MINIMUM OPERATING CURRENT under LABORATORY TESTING). This checks against an open operating circuit.

CONNECTION CHECK

Open Pilot Wires Or Cable Pilot Wires Of Less Than 1000 Ohms Loop Resistance.

1. Check to determine that there is no current in the CT neutral lead with normally balanced three-phase load current. Make this check on the relay at each end of the protected line.

2. At the end of the line, hereafter called the near end, temporarily open circuit the pilot circuit on the pilot-wire side of the insulating transformer, and connect the pilot-wire checking voltmeter (or any high-resistance voltmeter) across the open circuit.

Since the connections below will cause current to flow in the ground winding of the autotransformer, the voltmeter may read off scale. This can be prevented by changing the ground sensitivity adjustment to a tap that has a higher minimum operating current value; keeping in mind that if current transformers of different ratios are used, the sensitivity tap adjustments must be maintained in such a manner that the K factor of the two relays remain equal. (Refer to GROUND TAP SELECTIONS WITH UNEQUAL CT RATIOS).

3. Install test plugs No. 1 (Refer to Fig. 10) in both near and far end relays. Record the differential pilot-wire voltage. Reverse the pilot wires and record this voltage.

With test plug No. 1 still in the far-end relay, install test plugs No. 2 and then No. 3 in near-end relays and record their respective voltages, reversing pilot wires each time.

Determine which test plug connection has the lowest differential voltage. If it was other than test plug No. 1, reconnect external relay connections to 3, 4, or 5 so that the lowest reading is obtained with

Fig. 10 (36ZA601) Sh. 1
 Fig. 11 (36ZA601) Sh. 2

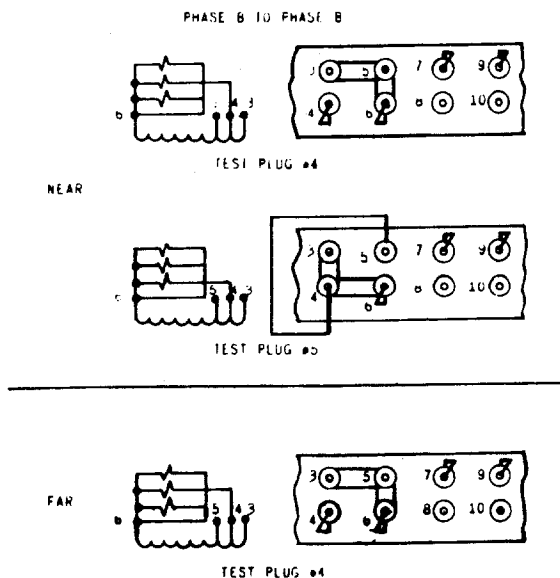
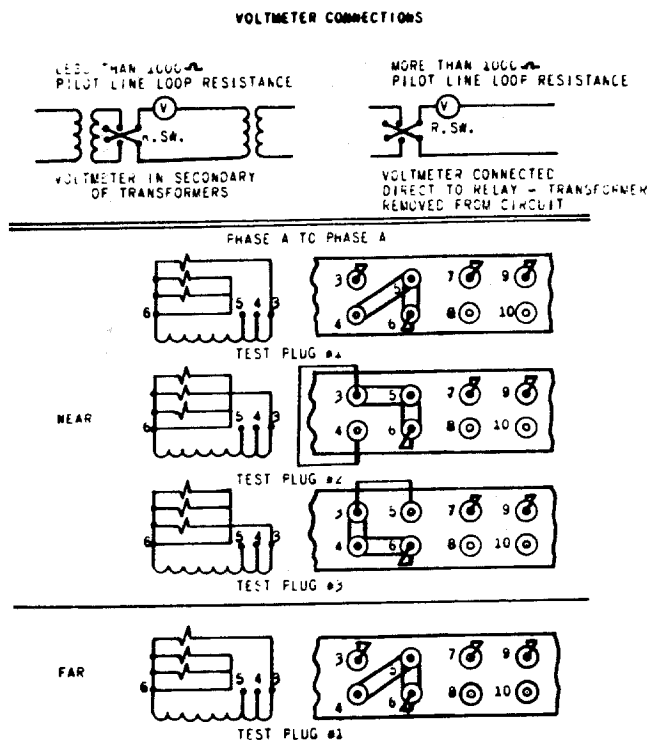

Fig. 10 Test Plug Arrangement for Checking Connections, Phase A to Phase A

Fig. 11 Test Plug Arrangement for Checking Connections, Phase B to Phase B

test plug No. 1 and normal pilot-wire connection. By this method the corresponding current for phase A is found and the pilot wire polarity verified.

To determine proper connections for phase B, proceed as follows:

Install test plug No. 4 (Refer to Fig. 11) in far and near end relays. Record the differential voltage in normally connected pilot lines. Install test plug No. 5 and record this voltage again. The lesser of the two readings is phase B. If necessary, reconnect external relay connections 4 and 5 so that the lowest reading is obtained with test plug No. 4.

Phase C will automatically be correct if phases A and B are connected correctly.

NOTE: When making these checks, it is necessary to choose a period when the line loads are relatively stable since readings taken at different times are being compared.

If any of the loads on the system are power rectifiers, these rectifiers may produce enough harmonic currents to cause apparently incorrect reading during the phasing out tests. To eliminate the harmonic currents in the relays a 50 muf capacitor should be connected across studs 3 and 6 of the Type CPD relay. A capacitor must be connected across the relays at both ends of the line.

The capacitors need only be connected during the phasing out tests. The relays will operate correctly even though there are harmonic currents flowing in its current coils.

If there is any question of whether there is a high harmonic content in the currents fed to the relay, it can be checked by connecting an oscilloscope either across studs 3 and 6 or across studs 7 and 9. The harmonics from a rectifier load are usually either 5th and 7th or 11th and 13th harmonics. Fig. 12 shows the current wave when an oscilloscope was connected across studs 7 and 9 of the Type CPD relay that was applied to a line supplying a power rectifier.

Cable Pilot Wires of Greater Than 1000 Ohms Loop Resistance.

Because of the capacity of the longer pilot wires of the cable type, it is sometimes impossible to determine the correct connections by the above method. For example: The minimum difference voltage may occur for phase B reversed if phase A is the correct phase. The procedure for checking the connections in this case will be somewhat different from outlined previously.

1. Check to determine that there is no current in the CI neutral lead with normally balanced three-phase load current. Make this check on the relay at each end of the protective line.
2. Check to determine that the phase sequence of the currents to the relay at each end of the line is A-B-C.
3. Remove the insulating transformers from the pilot-wire circuit. At each end connect the pilot wires to the leads formerly connected to the relay side of the insulating transformer.
4. Open circuit the pilot circuit at one end and connect the pilot-wire checking voltmeter across the open circuit.

Since current will flow in the ground winding of the autotransformer, the voltmeter may read off scale. This can be prevented by changing the ground sensitivity adjustment to a tap that has a higher minimum operating current value, keeping in mind that if current transformers of different ratios are used, the sensitivity tap adjustments must be maintained in such a manner that the K factor of the two relays remain equal. (Refer to GROUND TAP SELECTIONS WITH UNEQUAL C-T RATIOS).

5. Install test plug No. 1 (Refer to Fig. 10) in both near and far end relays. Record the difference in pilot-wire voltage. Record also the voltage applied to the pilot wires from the near end relay and the voltage received from the far end relay. With test plug No. 1 still in the far end relay, install test plug Nos. 2 and 3 and record their voltage as described above.

6. Noting that the test plugs apply currents to the relays of phase sequence A-B-C, use the readings from above to plot vectorially the three voltages applied to the pilot wire at the near end. Bearing in mind that no single phase can be reversed (item 1) and that the sequence is A-B-C (item 2), locate the voltage received from the far end relatively to the voltages at the near end. If the voltage from the far end is derived from phase A current, it will lag the voltage at the near-end by an angle of not more than 50 degrees. If the voltage received from the far end lags the voltage derived from phase A at the near end by more than 60 degrees or if it leads the near end voltage, the connections are not correct.

However, the correct combination can be determined and the connections changed accordingly. There are six possible combinations of voltages, only one of which is correct.

a. If the voltage from phase A of the far end is within the above prescribed limits of either of the two remaining near end vectors, that phase should be correctly called phase A. The others will follow in proper sequence.

b. If "a" does not apply, reverse all near end voltage vectors. This will determine which phase (near end) reversed is actually phase A and its polarity. If phase A (as used in item 5) reversed gives the correct combination, it is not necessary to change any current connections, merely reverse the pilot-wire leads at one end.

Reconnect the insulating transformers in the pilot-wire circuit. Connect the relays at both ends in phase A current circuit. To insure that the polarity has not been reversed when the insulating transformers were replaced, read the open-circuit voltage as before. (The open circuit can be on either side of the insulating transformer.) Reverse the pilot-wire leads to one insulating transformer and again read the open-circuit voltage. The correct polarity is the one which gives the smaller open-circuit voltage.

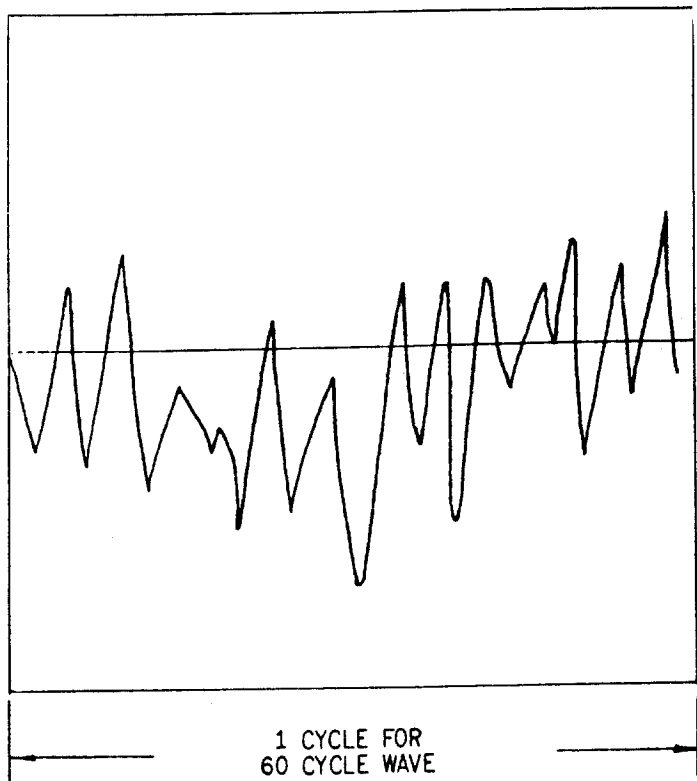

Fig. 12 Typical Wave Shape Seen on Oscillograph when Connected Across CPD Studs 7 & 9 when this Relay is Applied to a Line Supplying a Power Rectifier

Fig. 12 (416A760)

APPLICATION

RESTRAINT TAP

Determine the loop resistance of the pilot wires (twice the resistance of a single wire plus 140 ohms, the resistance of two insulating transformers).

Use tap according to the following table:

TABLE II

Pilot Wire Loop Resistance Including Insulating Transformers (Ohms)	Tap (Upper Tap Block)
0-120	1
120-280	2
280-470	3
470-730	4
730-1020	5
1020-1400	6
1400-2000	7

Note: Tap 1 is used only in cases where insulating transformers are not used.

PHASE TAP

The minimum three-phase pick-up is adjusted by means of taps on the middle tap block (2 tap plates). These taps may be used for one of the following purposes, but not both:

1. To set the phase pick-up independently of the ground pick-up.
2. To permit the use of current transformers of different ratios.

PHASE PICKUP SETTING

The following tabulation gives the phase pick-up currents with the three available taps:

TABLE III

Tap rating	2.7	4	5.4
Three-phase fault	2.7	4	5.4
Phases a-b or b-c fault	4.7	7	9.4
Phase c-a fault	2.35	3.5	4.7

All of these pick-up values are based on single-end feed with zero pilot-wire resistance. They will increase as the pilot-wire resistance increases as shown on Fig. 2. (If two circuit breakers are to be tripped, increase pick-up values 25 per cent).

In general, the 4 ampere phase tap is recommended, provided the minimum phase-to-phase fault current with single-end feed is 2 or more times the relay pick-up (7 amperes times factor M from Fig. 2). If the current is less than that value from Fig. 2). If the current is less than that value, the 2.7 ampere phase tap is recommended. In special cases, the 5.4 ampere tap may be desirable.

UNEQUAL C-T RATIOS

If the current transformer ratios differ in the ratio of 2:1, 3:2, or 4:3, phase taps can be chosen to obviate the necessity for auxiliary current transformers. For example, if the two current transformer ratios are 600/5 and 300/5, a primary current of 300 amperes corresponds, respectively, to secondary currents of 2.5 and 5 amperes, which are in the same ratio as phase taps 2.7 and 5.4. Consequently, phase tap 2.7 must be used at the terminal having 600/5 current transformers, and phase tap 5.4 must be used at the other end.

GROUND SENSITIVITY TAP

The ground sensitivity is set by the lower tap block, and the following instructions for determining the proper tap setting should be followed when the current transformer ratios at each end of the line are the same.

SINGLE END FEED

1. Determine the minimum secondary ground current (I_g) at end A (See Fig. 13) with circuit breaker B open. Also determine minimum I_g at end B with circuit breaker A open. Using the smaller of these currents, proceed to 2.

2. Factor M, determined from Fig. 2, raises the relay pick-up according to the pilot wire resistance. It can also be considered that less current is available by the inverse of factor M, or the current available is $\frac{I_g}{M}$.

3. Choose a tap value from the Table IV so that available current, I_g/M , is sufficiently above the pickup value to assure positive operation of the relay. (If two circuit breakers are to be tripped, increase pickup values 25 per cent).

For this minimum condition, a setting of two or three times pick-up is recommended. The same tap must be used at each end of the line in this case of equal current transformer ratio.

Under conditions of double-end feed, the distribution of fault current between the two terminals may be such that one relay does not receive enough current to cause operation until the breaker at the other terminal has opened. If such sequential tripping of the circuit breakers is considered to be unimportant, no further application work is necessary. To be sure that sequential tripping is

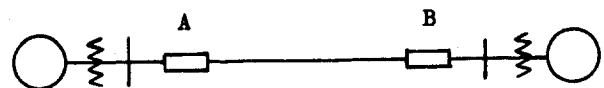

Fig. 13 Transmission Line

Fig. 13 (362A599)

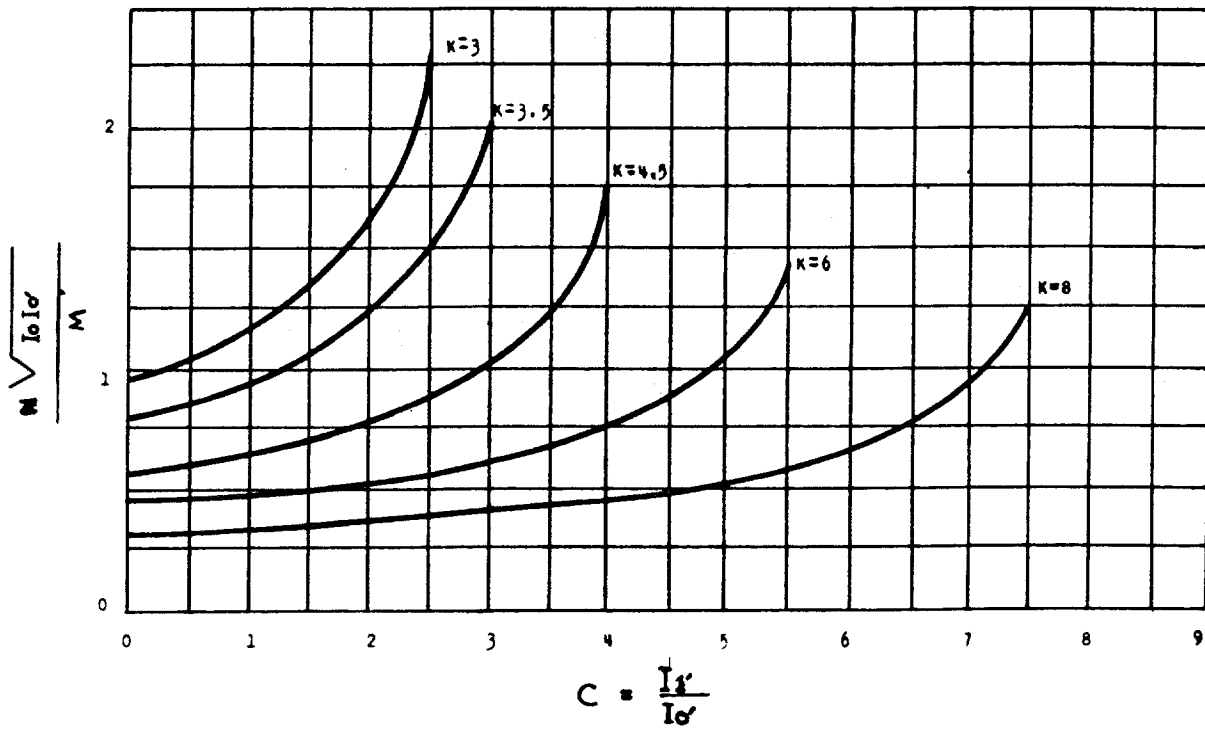

Fig. 14 (K-6154802)

Fig. 14 Pick-up Current Curves for the Type CPD11D Relay

avoided, it is necessary to consider double-end feed conditions, wherein it may be found necessary to change the tap determined above.

I_1' may not be calculated for a single-phase-to-ground fault. Constant C (See Step 2) can also be obtained as follows:

TABLE IV

Ground Fault Sensitivity Tap	Min. Oper. Current	Phase Tap		
		2.7	4	5.4
A	3.5	+	3	3.5
B	2.8	+	3.5	4.5
C	2.0	3.5	4.5	6
D	1.4	4.5	6	8
E	1.0	6	8	+

+ These tap combinations are not recommended.

DOUBLE-END FEED

1. In determining the setting of the relay required at the A (See Fig. 13) end of the line, calculate the following (under minimum fault conditions) for a fault on the B end of the line with both circuit breakers closed. **

I_0	Total zero phase-sequence component of fault current
I_0'	Zero-phase sequence component of fault current at end A only
I_1'	Positive-phase-sequence component of fault current at end A only

** Sometimes, substantially the same data may be available in slightly different form. For example,

Calculate $C_1 = \frac{\text{Current at station in question with 3-phase fault}}{\text{total 3-phase fault current}}$

Calculate $C_0 = \frac{I_0'}{I_0}$

Then $C = \frac{C_1}{C_0}$

2. Calculate $C = \frac{I_1'}{I_0'}$ (or $C = \frac{C_1}{C_0}$)

3. Calculate $N = \frac{4}{\text{phase-tap setting}}$

(Phase-tap setting is 2.7, 4, or 5.4 as determined in the previous section).

4. Calculate $N\sqrt{I_0 I_0'}$ (the current available to operate the relay).

5. Calculate $\frac{N\sqrt{I_0 I_0'}}{M}$ (again assume that the

available current is reduced by the inverse of M).

6. Referring to Fig. 14, curves are plotted for pick-up currents of the relay in terms of $\frac{N\sqrt{I_0 I_0'}}{M}$ against $C = I_1'/I_0'$. Choose a value of K so that $\frac{N\sqrt{I_0 I_0'}}{M}$ lies sufficiently above the curve corresponding to that value of K to insure positive operation of the relay. Here again, two or three times pick-up is recommended.

7. Repeat 1, 2, 3, 4, 5 and 6 for the relay at the B end of the line for a fault on the A end of the line,

determining new values I_0 , I_0' , $\frac{N\sqrt{I_0 I_0'}}{M}$, and C .

8. Choose the highest value of K determined in 6 and 7 above and for single-end-feed. Set both relays with that value of K , determining the tap (i.e., whether A, B, C, D or E) from Table IV.

If in 6 or 7, a value of K greater than that available is indicated, sequential breaker tripping may sometimes occur. It is possible, under certain conditions, still to avoid sequential breaker tripping but it is not within the scope of these instructions to consider these rather unusual conditions.

EXAMPLE OF GROUND-TAP SELECTION (Same C-T Ratios at Each End)

Given

1. Pilot resistance -500 ohms (loop resistance including resistance of insulating transformers.)

2. Phase-tap setting -4.

3. Minimum secondary ground currents, single-end feed.

a. Breaker B open, Fault at B,
 $I_g = 7.5$ amps.

b. Breaker A open, Fault at A,
 $I_g = 6.9$ amps.

4. Both Breakers Closed.

a. Fault at B, currents in relay at A.

$$I_0 = 7.3 \text{ amps.}$$

$$I_0' = 1.65 \text{ amps.}$$

$$I_1' = 3.6 \text{ amps.}$$

b. Fault at A, currents in relay at B.

$$I_0 = 7.0 \text{ amps}$$

$$I_0' = 2.4 \text{ amps}$$

$$I_1' = 2.4 \text{ amps}$$

Solution

A. Single-End-Feed

1. Smaller Current $I_g = 6.9$ amps.

2. Factor M (from Fig. 2) = 1.17

$$3. \frac{I_g}{M} = \frac{6.9}{1.17} = 5.9 \text{ amps}$$

4. Assuming that 5.9 amperes should be at least twice the pickup, it will be seen from Table IV that Tap B ($K = 3.5$) may be chosen.

B. Double-End Feed

1. Relay at A, Fault at B.

$$I_0 = 7.3 \text{ amps}$$

$$I_0' = 1.65 \text{ amps}$$

$$I_1' = 3.6 \text{ amps}$$

2. $C = 3.6/1.65 = 2.2$

3. $N = 4/4 = 1$

$$4. \sqrt{I_0 I_0'} = \sqrt{7.3 \times 1.65} = 3.47 \text{ amps.}$$

$$5. \frac{N\sqrt{I_0 I_0'}}{M} = \frac{3.47}{1.17} = 2.96 \text{ amps.}$$

6. Refer to pick-up curves Fig. 14. At $C = 2.2$, $K = 3.5$ is necessary for 2.96 amps to be at least twice pick-up.

$$\left(\frac{2.96}{1.3} = 2.28 \times \text{pick-up} \right)$$

7. Relay at B, Fault at A.

$$I_0 = 7.0 \text{ amps}$$

$$I_0' = 2.4 \text{ amps}$$

$$I_1' = 2.4 \text{ amps}$$

$$C = 2.4/2.4 = 1$$

$$N = 4/4 = 1$$

$$\sqrt{I_0 I_0'} = 7 \times 2.4 = 4.1 \text{ amps}$$

$$\frac{N\sqrt{I_0 I_0'}}{M} = \frac{4.1}{1.17} = 3.5 \text{ amps}$$

At $C = 1$, $K = 3$ would be sufficient.

8. $K = 3.5$ is the highest value of K determined above. Set both relays for $K = 3.5$ (tap B since the 4 ampere phase-tap is used).

GROUND TAP SELECTION WITH UNEQUAL C-T RATIOS

If the current transformer ratios are different, but of such ratios that the relay phase taps are able to compensate for the difference (See PHASE-TAP SETTING), the procedure for determining the ground tap setting is slightly different than in the case of current transformers of the same ratio. The differences are the following:

SOLUTION FOR SINGLE-END FEED

In step 1, use the smaller primary current and find the secondary current corresponding to this current.

The ground taps will be different at the two ends of the line in this case of unequal current transformer ratios. Determine the proper tap for the terminal with the smaller primary currents note its K-value, and then use the proper tap at the other terminal to provide the same K-value (See Table IV).

SOLUTION FOR DOUBLE-END FEED

1. Calculate C on a primary current basis, that is, in the formula $C = I_1' / I_0'$, use primary currents for I_1' and I_0' instead of secondary currents.

2. Calculate $\sqrt{I_0 I_0'}$ on a primary current basis, then divide by the current transformer ratio of the current transformers supplying the relay at the station in question. Thus, in the preceding example for double-end feed, if the current transformer ratios at stations A and B were 400/5 and 300/5 respectively, step 4 would consist of finding

$\sqrt{I_0 I_0'}$ on a primary current basis and dividing by 80, whereas in step 7, $\sqrt{I_0 I_0'}$ on a primary current basis and dividing by 60.

3. As in step 8 of the preceding example, the highest K tap should be chosen, but the actual tap (i.e., whether A, B, C, D, or E) will be different at the two terminals. The tap can be determined, as before, from Table IV.

EXAMPLE OF GROUND TAP SELECTION (Different C-T Ratios at Each End)

Given

1. Pilot resistance - 500 ohms (loop resistance).
2. Current Transformer ratios.
Terminal A - 400/5
Terminal B - 300/5

3. Minimum Primary ground currents, single-end-feed.

- a. Breaker B open, Fault at B, $I_g = 600$
- b. Breaker A open, Fault at A, $I_g = 550$

4. Both Breakers Closed. Primary Currents.

a. Fault at B, currents at A.

$$I_0 = 585$$

$$I_0' = 132$$

$$I_1' = 288$$

b. Fault at A, currents at B.

$$I_0 = 560$$

$$I_0' = 192$$

$$I_1' = 192$$

Solution

A. Single-End Feed

The phase taps to compensate for different current transformer ratios will have already been determined. They are the following:

At terminal A (400/5 CT) - 4 ampere tap

At terminal B (300/5 CT) - 5.4 ampere tap

1. Smaller primary current $I_g = 550$ amperes at terminal B.

Since the current transformers at terminal B are 300/5 ratio, secondary.

$$I_g = \frac{550}{60} = 9.15 \text{ amps}$$

2. Factor M (from Fig. 2) = 1.17

$$\text{Secondary } I_g = \frac{9.15}{1.17} = 7.85 \text{ amps}$$

3. Refer to ground pick-up currents on Table IV. Assuming at least twice the pickup is desired, tap A can be used, since its pickup is 3.5, or the multiple of pick up is $\frac{7.85}{3.5} = 2.2$. Tap A at terminal

B, then, has a K of 3.5, since the phase tap is 5.4. Consequently, at terminal A, with phase tap 4, ground tap B should be used to provide a K of 3.5.

B. Double-End-Feed

1. Relay at A, Fault at B.

$$\text{Primary } I_0 = 585$$

$$\text{Primary } I_0' = 132$$

$$\text{Primary } I_1' = 288$$

$$2. C = I_1' / I_0' = 288 / 132 = 2.2$$

$$3. N = 4 / 4 = 1$$

4. On primary current basis $\sqrt{I_0 I_0'} = \sqrt{585 \times 132} = 277$

On secondary basis $\sqrt{I_0 I_0'} = 277/80 = 3.47$

5. $\frac{N \sqrt{I_0 I_0'}}{M} = \frac{3.47}{1.17} = 2.96$

6. Same as previous example.

7. Relay at B, Fault at A.

Primary $I_0 = 560$
 Primary $I_0' = 192$
 Primary $I_1' = 192$

$C = \frac{192}{192} = 1$

$N = 4/5.4 = .75$

Primary current basis, $\sqrt{I_0 I_0'} = \sqrt{560 \times 192} = 328$ amps

Secondary basis $\sqrt{I_0 I_0'} = 328/60 = 5.47$

$\frac{N \sqrt{I_0 I_0'}}{M} = \frac{0.75 \times 5.47}{1.17} = 3.5$ amps

As in previous example $K = 3.5$ is sufficient.

8. As in previous example $K = 3.5$ is the highest value of K determined above. Set both relays for $K = 3.5$. From Table IV, $K = 3.5$ requires ground tap B for phase tap 4, ground tap A for phase tap 5.4. Consequently, at terminal A use ground tap B and at terminal B, use ground tap A.

Fig. 15 (K-6375606)

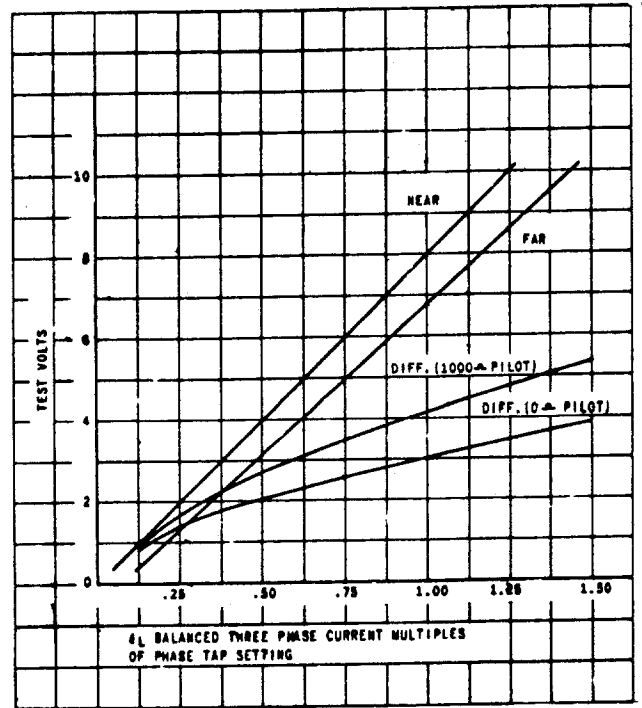

Fig. 15 Typical Test Values for 60 Cycle Type CPD11D Relays with Insulating Transformers

MAINTENANCE

PERIODIC TESTING

1. A high resistance voltmeter and an SB-1 switch are furnished with each relay. These should be connected according to external diagram, Fig. 8. The operating routine should be set up so that pilot wire continuity is checked at different intervals. When the switch is operated to the remote position, a voltage will be read if the pilot wires are neither open-circuited or short-circuited and if sufficient load current is flowing. If the switch is operated to the "local" position a corresponding voltage as produced by the local relay will be read. The far voltage will be slightly lower than the near voltage (see Fig. 14) because of voltage drop due to voltmeter current, pilot wires and insulating transformers.

2. A third position, the "difference" position, has been added to the test switch to detect a reversal of pilot wires if the pilot channel has been opened for any reason. In general, the difference voltage should be less than either the far or near voltage for correct polarity, but at low values of load current the difference voltage may exceed the

far voltage reading even with correct polarity. The curves of Fig. 15 are typical of the voltages to be expected for various values of balanced three-phase line current and with correct polarity of pilot wires.

3. An operation test and inspection of the relay every six months is recommended. The calibration of the individual relay may be checked as described under the heading MINIMUM OPERATING CURRENT in the LABORATORY TESTING section of this book.

If it is desired to make a more thorough overall check of relay and pilot-wire connections for a particular pair of relays, the following tests may be conducted to simulate the conditions of through faults, internal faults and single-end feed, and internal faults with double-end feed.

1. Through faults check: By installing the test plug connections illustrated in Fig. 17 a system fault other than that area protected by this relay is simulated. Neither relay should trip.

2. Single-end feed internal fault check: By installing test plug connections illustrated in Fig. 16, the near end relay should trip. This test verifies that the relay will trip if there is an internal fault.

3. Double-end feed, internal fault check: By installing test plug connections illustrated in Fig. 19, both relays should trip. This test verifies proper relay operation in case of an internal system fault.

ADJUSTMENT AND CARE

The relay was properly adjusted at the factory and it is advisable not to disturb these adjustments. If, for any reason it becomes necessary to remove the contact plate and rotor, proceed in the following manner:

1. Disconnect the leads which go through the mounting plate to the contact plate, disconnecting at the contact plate.
2. Remove the two screws which secure the upper bearing plate.
3. The contact plate is secured to the element by means of three screws. The screws are located on the right-hand and left-hand sides at the front end and in the middle at the rear. Remove the three screws.
4. The shaft, rotor and upper bearing plate will lift out with the contact plate.

5. The rotor may be removed from the shaft by loosening the two set screws which fit into V-holes in the shaft when the rotor is properly placed on the shaft.

The two stator castings are permanently fastened together with the laminations clamped between them and the faces of the poles and the cylindrical surfaces on these castings are then machined true about the same axis. To preserve this alignment the large rivets in the corners should never be removed.

Use care in handling the rotor while it is out of the relay, and see that the air gap and rotor are kept clean.

In reassembly, the rotor will go into the air gap easily without forcing if the parts are held in line properly.

BEARINGS

The lower jewel bearing should be screwed all the way in until its head engages the end of the threaded core. The upper bearing should be adjusted to allow about 1/64" end play to the shaft.

The lower jewel may be tested for fractures by exploring its surface with a fine needle.

CONTACTS

For cleaning fine silver contacts, a flexible furnishing tool should be used. This consists of a

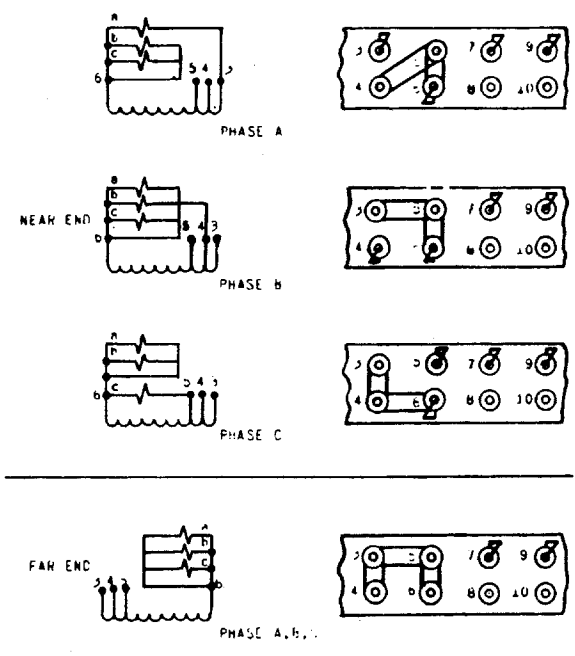

Fig. 16 Test Plug Arrangement for Simulated Internal Fault, Single-end Feed

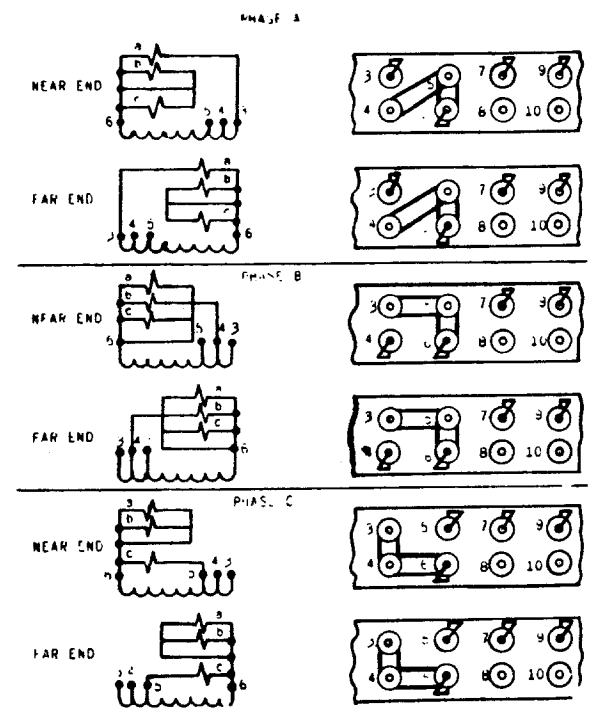

Fig. 17 Test Plug Arrangement for Through Faults Check

Fig. 16 (362A600) Sh. 3

Fig. 17 (362A600) Sh. 2

Fig. 18 (K-6077069)

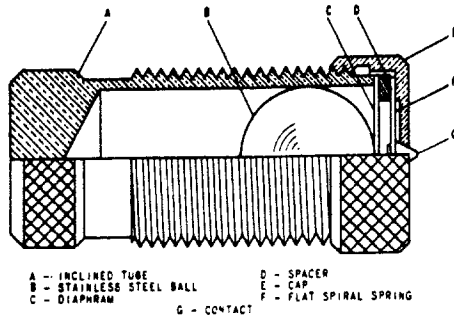

Fig. 18 Stationary Contact Assembly

flexible strip of metal with an etched roughened surface, resembling in effect a superfine file. The polishing action is so delicate that no scratches are left, yet corroded material will be removed rapidly and thoroughly. The flexibility of the tool insures the cleaning of the actual points of contact.

Fine silver contacts should not be cleaned with knives or files may leave scratches which increase arcing and deterioration of the contacts. Abrasive paper or cloth may leave minute particles of insulating abrasive material in the contacts, thus preventing closing.

The burnishing tool described above can be obtained from the factory.

Each stationary contact (Fig. 18) is mounted on a flat spiral spring (F) backed up by a thin diaphragm (C). These are both mounted in a slightly inclined tube (A). A stainless steel ball (B) is placed in the tube before the diaphragm is assembled. When the moving contact hits the stationary contact, the energy of the former is imparted to the latter and thence to the ball, which is free to roll up the inclined tube. Thus, the moving contacts come to rest with substantially no rebound or vibration. To change the stationary contact brush remove the contact barrel and sleeve as a complete unit after loosening the screw at the front of the contact block. Unscrew the cap (E). The contact brush may then be removed. The two contact barrels should be adjusted so that the two contacts close as nearly as simultaneously as possible (see MINIMUM OPERATING CURRENT under LABORATORY TESTING).

The contact gap may be adjusted after lining up the contacts by means of the shock backstop at the front on the right. This gap should be approximately 0.50".

Each moving contact may be removed by loosening the screw which secures it to the contact arm and sliding it from under the screw head.

HOLDING COIL

The location of the holding coil may be adjusted by loosening the mounting screw and sliding the coil either to the left or the right in a groove provided for that purpose. The holding coil is located in the

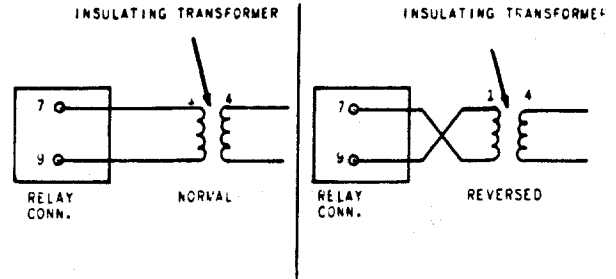

- (1) REVERSE RELAY CONNECTIONS TO PILOT WIRE AT EITHER END.
- (2) MAKE CIRCUIT CONNECTIONS AS FOR THROUGH FAULTS.

Fig. 19 Simulated Internal Faults Double-End Feed

factory so that there is a gap of about 0.040" to 0.055" between the pole pieces and the armature. A gap of 0.040" is equivalent to 1-1/4 turns of the contact barrel. The holding coil gap must not be adjusted appreciably below 0.040"

CONTROL AND LEAD-IN SPRING

The control and lead-in springs are adjusted in the factory so that the contacts are open when the relay is de-energized. The tension of the control spring may be changed by loosening the hexagonal screw located at the rear of the adjusting ring guide and then turning the adjusting ring to the desired position.

LABORATORY TESTING

If more comprehensive tests are desired, the following suggestions may be of value:

Connect terminals 9 and 6 together. With 5 amperes, rated frequency in terminals 3 and 6, tap E of the lower tap block, and any taps of the middle and upper tap blocks, the voltage across terminals 3 and 7 (high resistance voltmeter) should be less than the voltage across terminals 9 and 7.

SATURATION CHECK ON AUTOTRANSFORMER

The standard Type CPD relay is designed to have a saturation characteristic which limits the magnitude of the voltage applied to the pilot wire. This voltage should not exceed 120 volts as measured by a high-resistance, rectifier-type voltmeter.

With 40 amps at rated frequency in terminals 3 and 6, tap 7 of upper tap block, tap 4 of the middle tap block, and tap E of the lower tap block, measure the voltage across terminals 7 and 9.

MINIMUM OPERATING CURRENT

The minimum operating current can be adjusted by changing the tension of the upper control spring. This may be done by loosening the hexagonal screw located at the rear of the adjusting ring guide and then turning the adjusting ring. Under the above conditions, it is not recommended that the pick-up be adjusted appreciably below 1 ampere. The pick-up may be increased above 1 ampere but it must be

Fig. 19 (362A600) Sh. 1

remembered that all pick-ups will be increased in proportion.

With current of rated frequency in terminals 5 and 6, tap 1 of the upper tap block, tap 4 of the middle tap block, tap E of the lower tap block, and terminal 7 and 9 connected to the corresponding terminals of an identical relay, the minimum operating current to close the contact connected to terminal 2 (front contact) should be approximately 1 ampere. The rear contact (terminal 10) should close at the same time or slightly after the front contact. Check contact closure of the rear contact with a suddenly applied current of 1.25 amperes (momentary closure of this contact is satisfactory).

If a second relay is not available, as in the case of field testing, short circuit terminals 7 and 9. With the upper (restraint) tap in position 1 and the lower (ground sensitivity) tap in position E, the minimum operating current should be approximately 0.7 ampere.

OPERATING-RESTRAINING CURVE (THROUGH FAULT)

Since this is an overall test, two identical relays must be available.

Connect the relays according to Fig. 20.

Use tap 1 of the upper tap block, tap 4 of the middle tap block, and tap E of the lower tap block.

With various values of I_B from zero to 10 or 15 amperes, raise current I_D until relay A operates. (Relay B will not operate). To check relay B, interchange the relays. The curves obtained should approximate Fig. 4 for 60 cycle relays, Fig. 5 for 25 cycle relays, and Fig. 6 for 50 cycle relays. Note that the two curves are plotted on the basis of multiples of minimum operating current with single-end feed, which is the value obtained when $I_B = 0$.

STABILITY OF RELAYS WHEN THROUGH FAULT IS REMOVED

With the connections of the preceding tests, except with the I_D circuit open, apply about 40 amperes to the relays (I_A and I_B). When this current is removed, neither contact should close. If the contacts of a relay close, the clutch should be adjusted. Whether the clutch has to be tightened or loosened needs to be determined by trial. The clutch is adjusted by means of a screw on the right-hand side of the moving contact arm near the shaft. To tighten the clutch, loosen the locknut, and turn the screw in the clockwise direction. Be sure to tighten locknut after this adjustment.

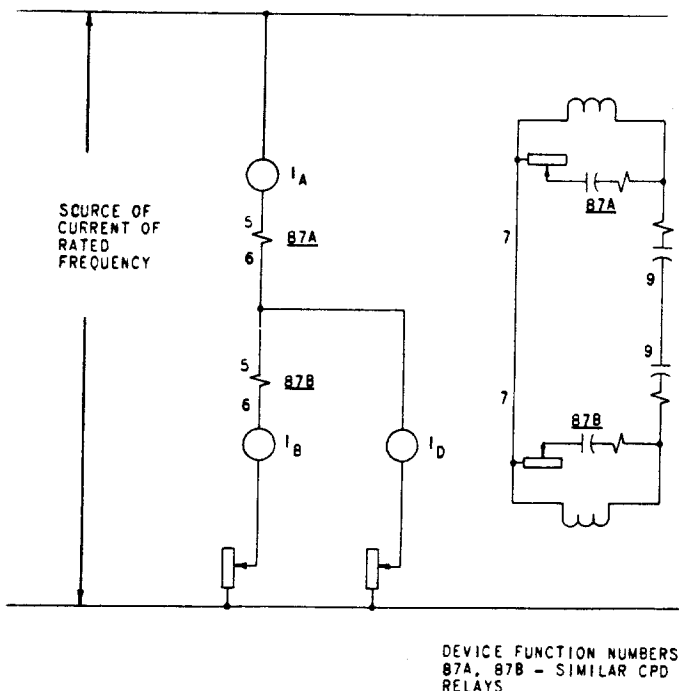

Fig. 20 Testing Connections for the Type CPD Relay

Fig. 20 (K-6154645)

RENEWAL PARTS

It is recommended that sufficient quantities of renewal parts be carried in stock to enable the prompt replacement of any that are worn, broken, or damaged.

When ordering renewal parts, address the nearest Sales Office of the General Electric Company, specifying the quantity required and describing the parts by catalogue numbers as shown in Renewal Parts Bulletin No. GEF-3387.

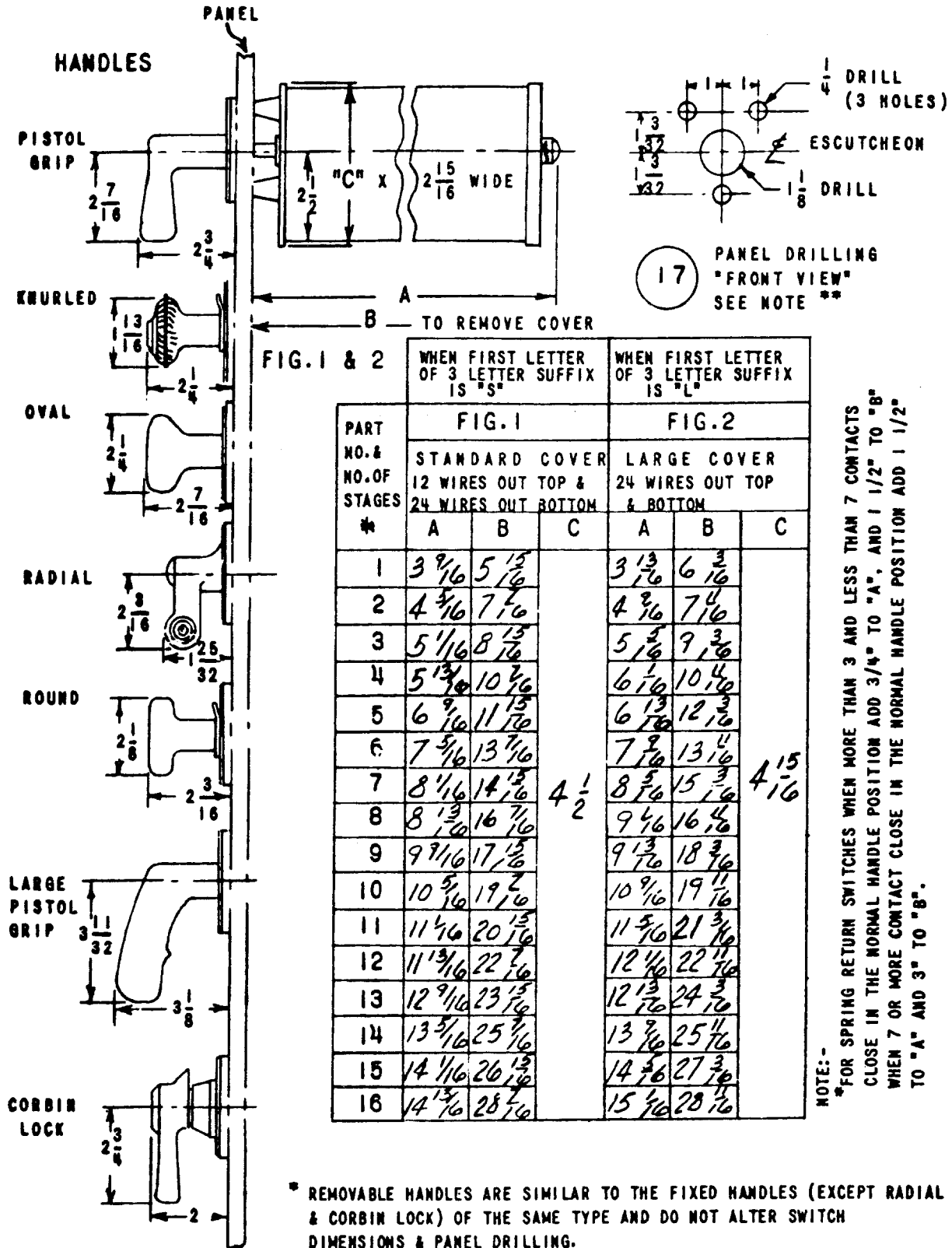

Fig. 23 Outline and Dimensions for Test Switch, Type SB-1

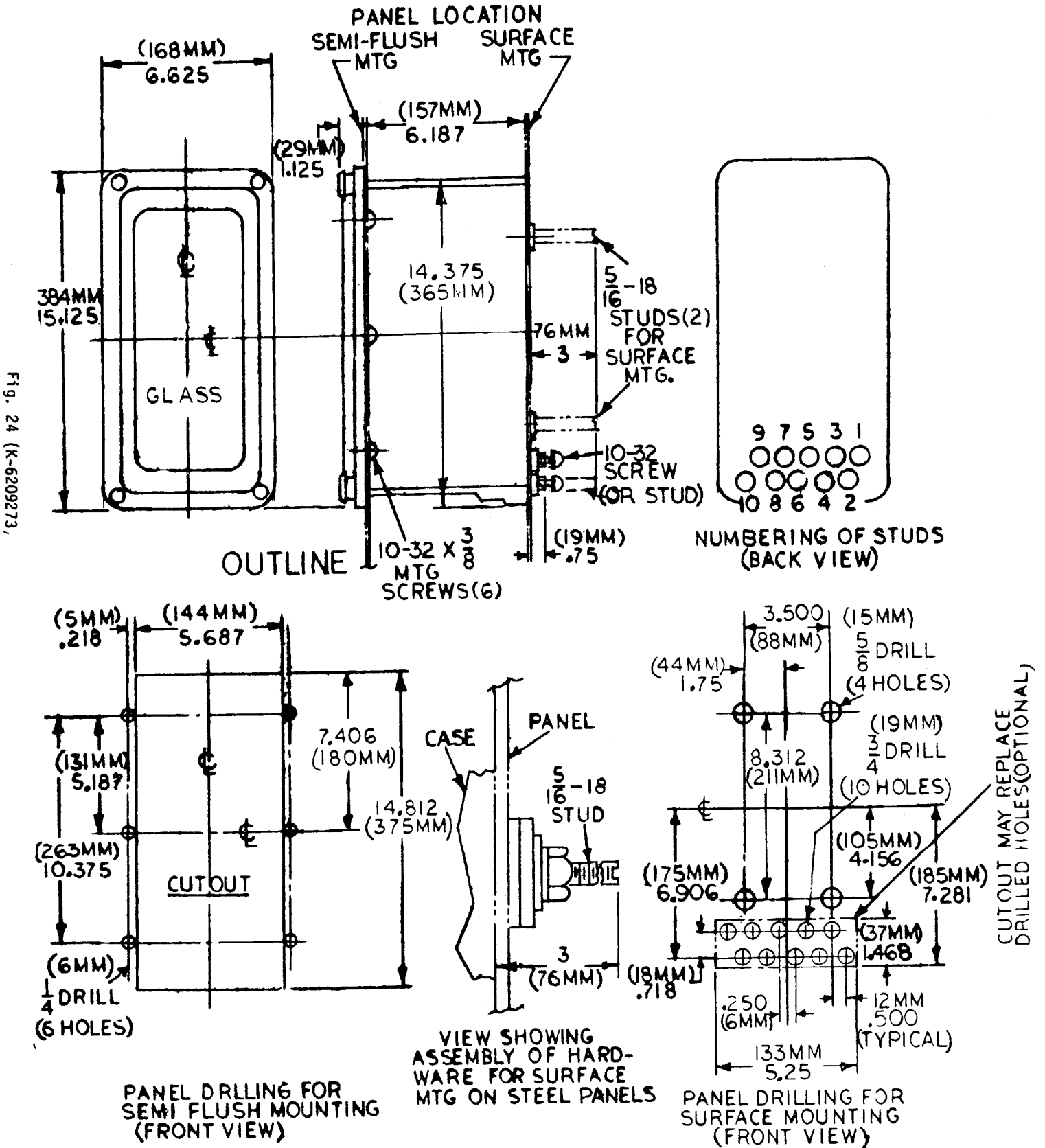

Fig. 24 Outline and Panel Drilling Dimensions for the Type CPD11D Relay



GE Power Management

215 Anderson Avenue
Markham, Ontario
Canada L6E 1B3
Tel: (905) 294-6222
Fax: (905) 201-2098
www.GEindustrial.com/pm