



INSTRUCTIONS

GEK-86650

DATA LOGGING AMPLIFIER

TYPE DLA52F

GENERAL  ELECTRIC

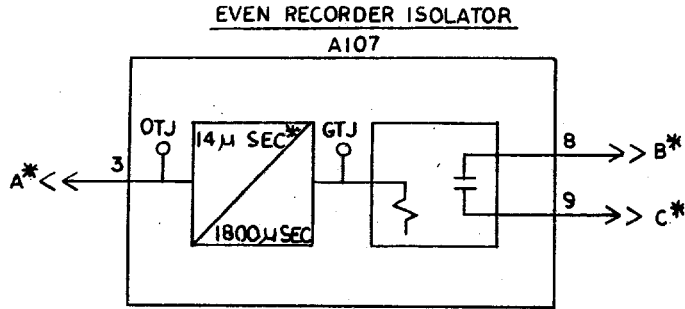

REED RELAY - ELECTROL RA30021981
CONTACT RATING: 10VA MAX.
250VA MAX.
0.5A MAX.

*=INPUT PULSE GREATER THAN 40μ SEC
REQUIRED TO GIVE FULL DROP OUT TIME

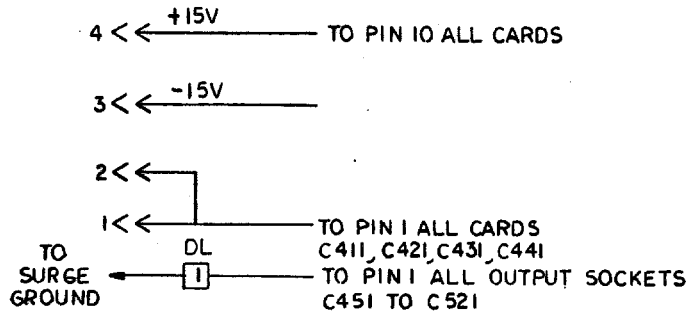

A*	B*	C*	A*	B*	C*
INPUT SIGNAL	A107 LOCATION	OUTPUT CONTACT	INPUT SIGNAL	A107 LOCATION	OUTPUT CONTACT
412	AE	452,453	428	R	488,489
413	AF	454,455	429	P	492,493
414	AG	456,457	430	N	494,495
415	AH	458,459	432	M	496,497
416	AJ	462,463	433	L	498,499
417	AK	464,465	434	K	502,503
418	AL	466,467	435	J	504,505
419	AM	468,469	436	H	506,507
420	AN	472,473	437	G	508,509
422	AP	474,475	438	F	512,513
423	AR	476,477	439	E	514,515
424	AS	478,479	440	D	516,517
425	AT	482,483	442	C	522,523
426	T	484,485	443	B	524,525
427	S	486,487	444	A	526,527

Figure 1 (0183B3670-1) Internal Connections Diagram for the DLA52F Relay

DATA LOGGING AMPLIFIER TYPE DLA52F

DESCRIPTION

The Type DLA52F is a transistorized data logging amplifier used for oscillograph monitoring of up to twelve points in a MOD III type static relaying scheme. These points are shown on the overall logic diagram of the relaying scheme. The DLA52F has contact outputs to operate an oscillograph. The DLA amplifier prevents undue loading and possible malfunctioning of the relay circuitry that is monitored. The DLA52F amplifier requires a DC power source and bias voltages which may be obtained from a Type SSA power supply.

The internal connections for the DLA52F are given in Figure 1. This relay is built into a two rack unit case whose outline and mounting dimensions are given in Figure 2. The component locations for the Type DLA52F are shown in Figure 3.

RATINGS

The DLA52F is designed for use in an environment where the ambient temperature outside the case does not vary beyond the limits of -20°C or $+65^{\circ}$.

The DLA52F is designed to operate on a bias voltage of plus 15 volts DC. This voltage may be obtained from a Type SSA power supply.

The contact outputs of the DLA52F are rated for a maximum load of ten volt-amperes. Maximum current is 500 milliamperes and maximum voltage is 250 volts DC.

BURDENS

The DLA52F presents a burden of 480 milliamperes to the positive DC power supply when all circuits are ON (Logic One). It presents a burden of 150 milliamperes to the positive DC power supply when all circuits are OFF (Logic Zero).

CIRCUIT DESCRIPTION

The DLA52F is used when monitoring relay circuitry functions involving current-sinking type logic, where the presence or absence of signals, rather than their magnitude, controls the operation. Therefore signals below one volt represent an OFF condition (Logic Zero) with respect to the reference bus, while signals resulting in an ON condition (Logic One) are generally in the range of plus 12 to plus 15 volts. Current-sinking type logic is a logic system where the output stage that is OFF actually draws current from the stage driven to prevent it from turning ON.

These instructions do not purport to cover all details or variations in equipment nor to provide for every possible contingency to be met in connection with installation, operation or maintenance. Should further information be desired or should particular problems arise which are not covered sufficiently for the purchaser's purposes, the matter should be referred to the General Electric Company.

To the extent required the products described herein meet applicable ANSI, IEEE and NEMA standards; but no such assurance is given with respect to local codes and ordinances because they vary greatly.

The circuit for the DLA52F is shown in Figure 4. The circuitry is basically that of a transistor switch, and it operates as follows. The presence of a positive input signal with a duration of 14 microseconds or more at pin 3 of the A107 card will cause the relay on the card to pick up, thus closing the contacts connected between pins 8 and 9 on the card. If this input signal is removed, the contacts connected between pins 8 and 9 on the card will reopen after a delay of up to 1.8 milliseconds. The complete 1.8 milliseconds of dropout delay will be obtained if the duration of the input signal was 35 microseconds or more.

CONSTRUCTION

The DLA52F is packaged in a enclosed metal case which is suitable for mounting on one standard 19 inch rack. The outline and mounting dimensions of this case, and the physical location of the components, are included in this instruction book.

External connections to the DLA52F are made at the back of the unit. Sockets for interconnecting the DLA input with the static relay logic units are marked C411 through C521. Arrangement of these sockets is shown on the DLA52F component location drawing, Figure 3.

TESTING

GENERAL

The DLA52F is usually supplied from the factory mounted in a static relay equipment. All units for a given terminal of static relaying are tested together at the factory and each has the same summary number stamped on its nameplate. When the DLA is furnished as a separate unit, it should be interconnected with the associated relay equipment via shielded plug-in cables before testing.

INSTALLATION TESTS

WARNING: THE LOGIC SYSTEM SIDE OF THE DC POWER SUPPLY USED WITH MOD III STATIC RELAY EQUIPMENT IS ISOLATED FROM GROUND. IT IS A DESIGN CHARACTERISTIC OF MOST ELECTRONIC INSTRUMENTS THAT ONE OF THE SIGNAL INPUT TERMINALS IS CONNECTED TO THE INSTRUMENT CHASSIS. IF THE INSTRUMENT USED TO TEST THE RELAY EQUIPMENT IS ISOLATED FROM GROUND, ITS CHASSIS MAY HAVE AN ELECTRICAL POTENTIAL WITH RESPECT TO GROUND. THE USE OF A TEST INSTRUMENT WITH A GROUNDED CHASSIS WILL NOT AFFECT THE TESTING OF THE EQUIPMENT. A SECOND GROUND CONNECTION TO THE EQUIPMENT, SUCH AS A TEST LEAD INADVERTENTLY DROPPING AGAINST THE RELAY CASE, MAY CAUSE DAMAGE TO THE LOGIC CIRCUITRY. NO EXTERNAL TEST EQUIPMENT SHOULD BE LEFT CONNECTED TO THE STATIC RELAYS WHEN THEY ARE IN PROTECTIVE SERVICE, SINCE TEST EQUIPMENT GROUNDING REDUCES THE EFFECTIVENESS OF THE ISOLATION PROVIDED.

Since the DLA52F logic sections are basically transistor switches, adjustments are neither provided nor required. The various functions that are monitored and therefore serve as inputs to the DLA are covered in the overall logic diagram and logic description furnished with each equipment.

MAINTENANCEPERIODIC TESTS

It should be sufficient to check the DLA outputs by observing oscillograph operation during periodic calibration tests made on the associated measuring units of the relaying scheme. No separate periodic tests of the DLA itself should be required.

TROUBLESHOOTING

Signal tracing, using the overall logic diagram and the various equipment test points, should quickly isolate a DLA malfunction. A test adapter card, 0108B9643G2, is supplied with each static relay equipment to supplement the prewired equipment test points. Use of the adapter card is described in the printed circuit card instruction book GEK-34158.

SPARE CARDS

The number of spare cards to be stocked depends on the total number of similar cards used at the same location or serviced by the same test group. For each type of card (different code designation) a suggested minimum number of spare cards would be:

- 1 spare for one to 25 cards
- 2 spares for 26 to 75 cards
- 3 spares for 76 to 150 cards.

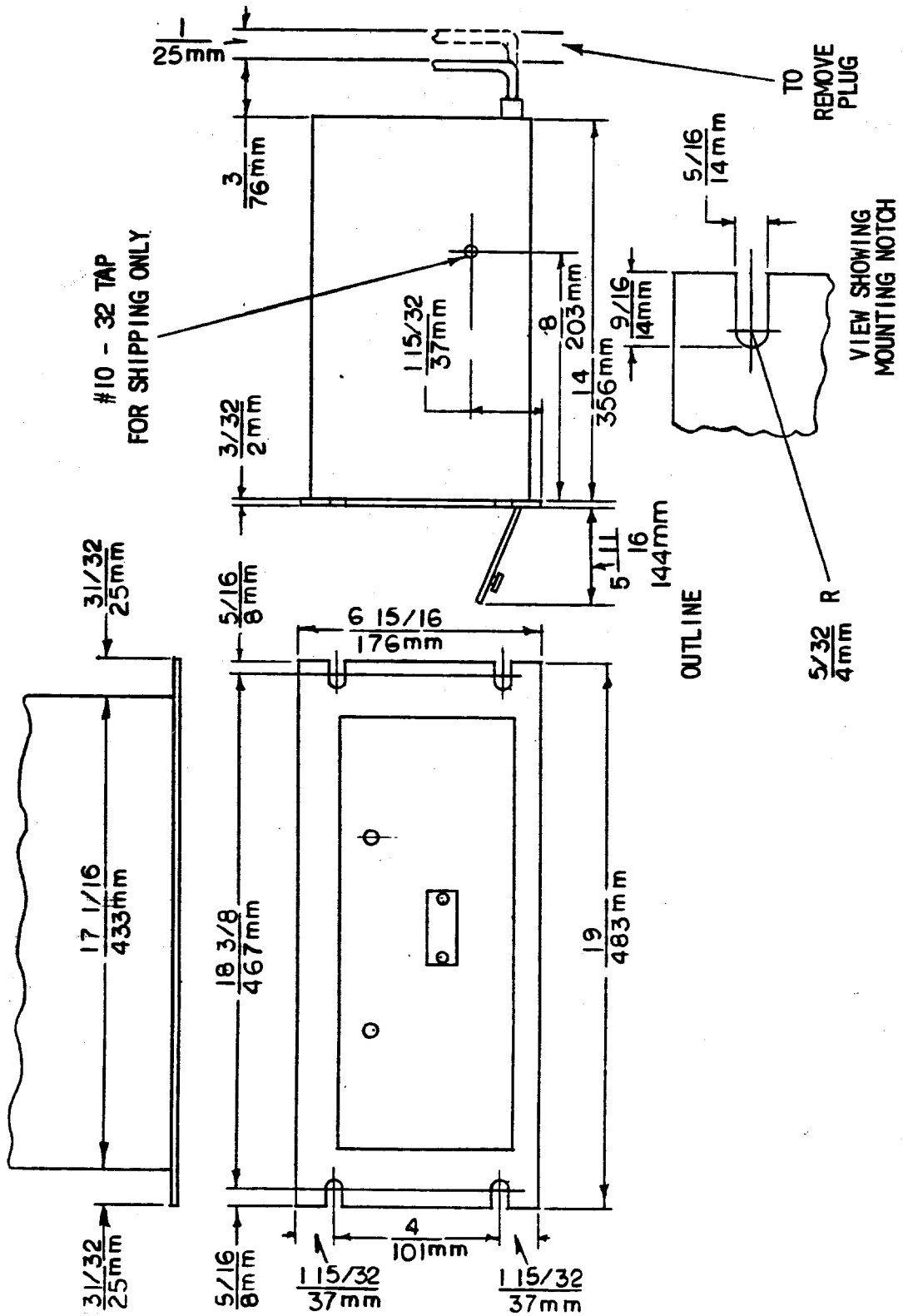

Figure 2 (0227A2037-0) Outline and Mounting Dimensions for the DLA52F Data Logging Amplifier

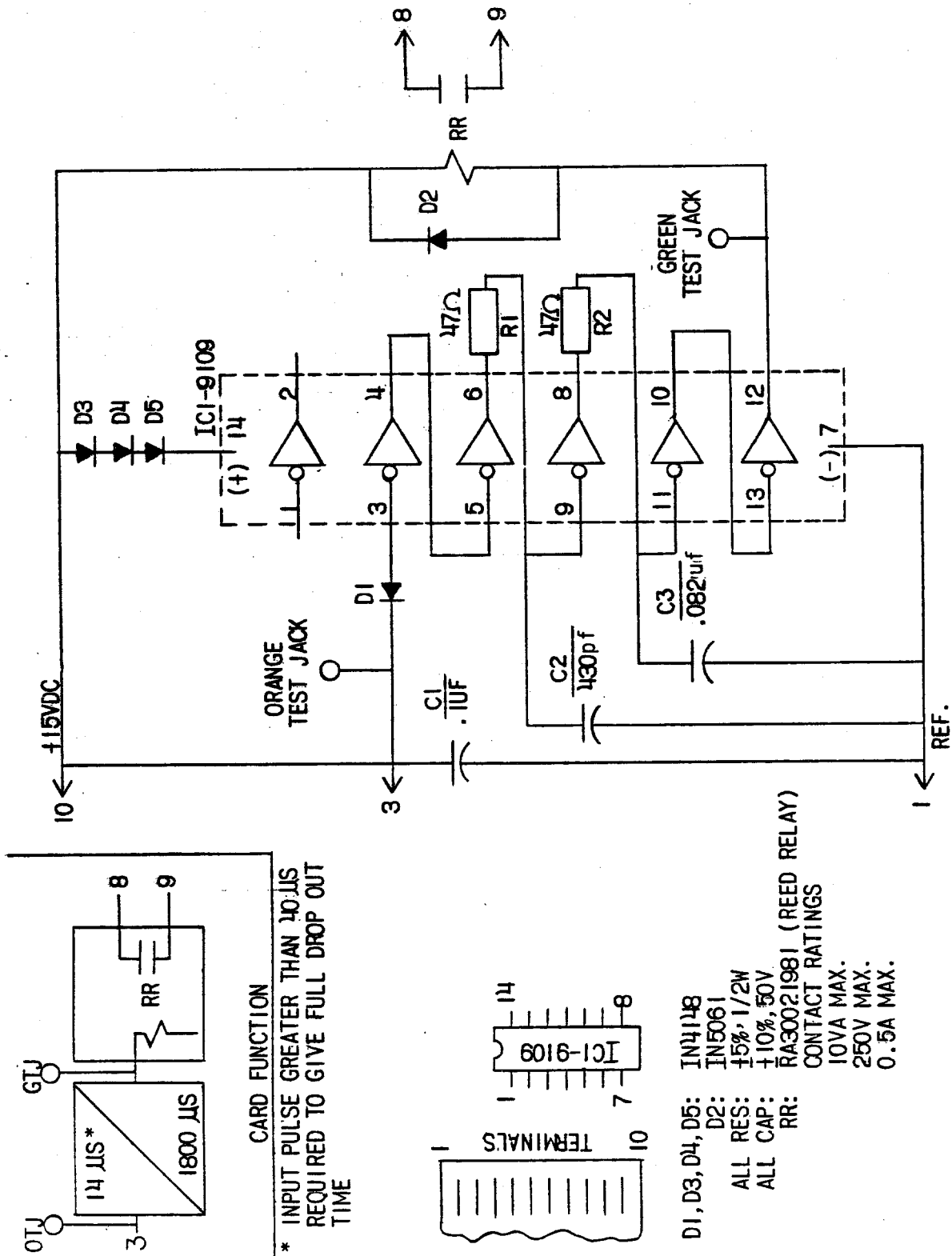

Figure 4 (0148A3903MP-0) DLA52F Data Logging Amplifier Circuitry

P.C. CARD 0149C7277 G-2

