

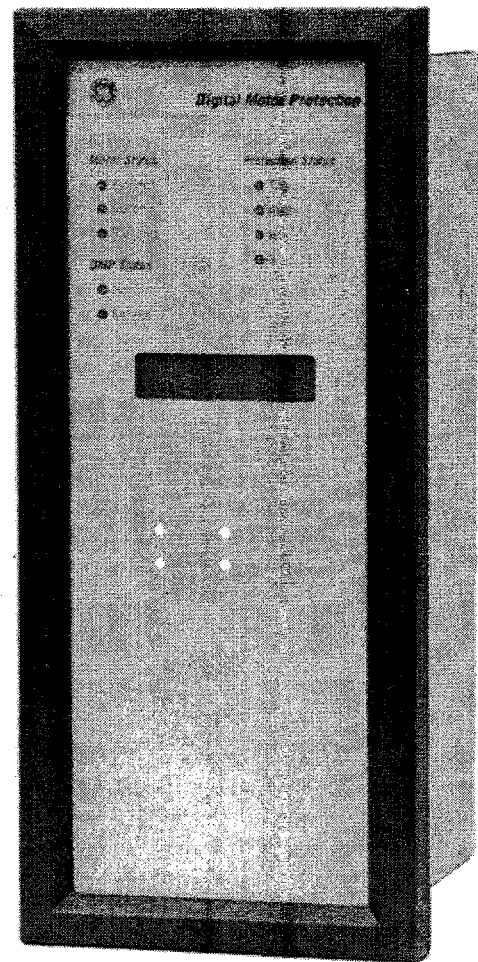

DMP2 and DMP3 Relays

User's Manual

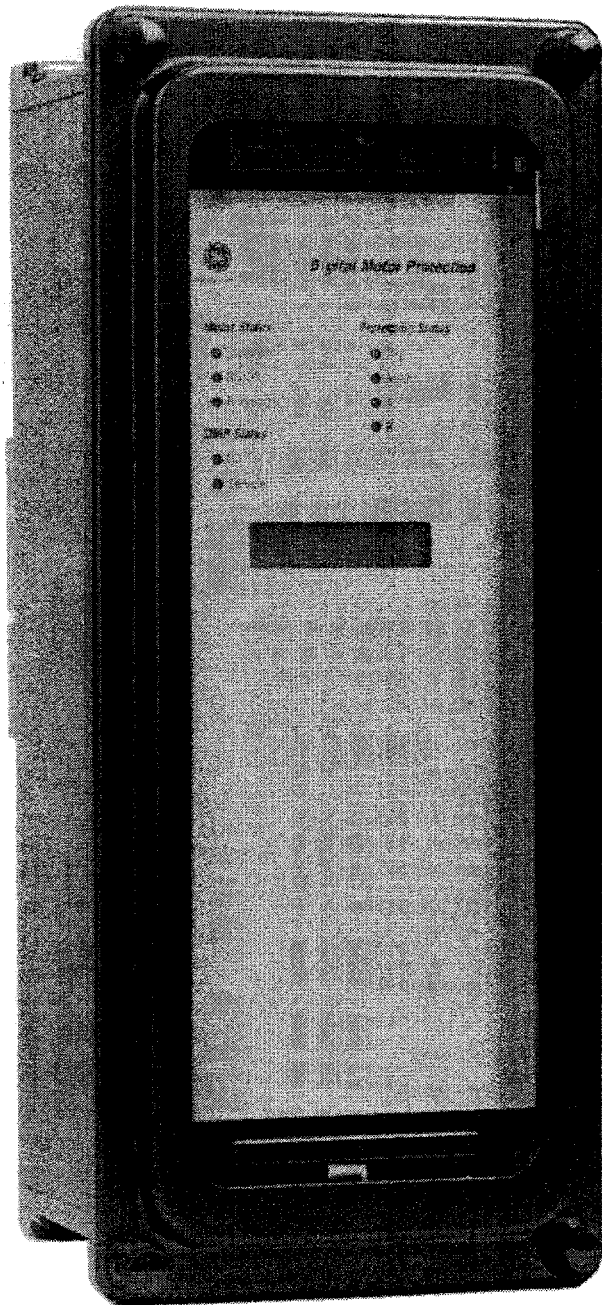

Getting Started

Since this relay is available in a variety of configurations, take a moment to compare the catalog number of your purchased relay with the catalog number key below.

Code	Description
1	Motor protection and control with voltage inputs
2	Motor protection with voltage inputs
3	Basic motor protection
D	Drawout construction (M2 case)
V	Fixed case, vertical orientation
H	Fixed case, horizontal orientation
C	10 ohm copper RTD
P	100 ohm platinum, 120 ohm nickel RTD
1	115/230 Vac power supply
2	110–250 Vdc power supply
3	24–48 Vdc power supply
1	RS–485 communication port
	Revision level

DMP Motor Protection Relay System catalog number system.

Example – a relay with catalog number DMP1VC21A has the following features:

- Motor protection and control with voltage inputs (1)
- Fixed case, vertical orientation (V)
- 10 ohm copper RTD (C)
- 110–250 Vdc power supply (2)
- RS 485 communication port (1)
- Revision level A

GEK-105499

WARNINGS, CAUTIONS, AND NOTES AS USED IN THIS PUBLICATION

WARNINGS

Warning notices are used in this publication to emphasize that hazardous voltages, currents, or other conditions that could cause personal injury exist in this equipment or may be associated with its use.

Warning notices are also used for situations in which inattention or lack of equipment knowledge could cause either personal injury or damage to equipment.

CAUTIONS

Caution notices are used for situations in which equipment might be damaged if care is not taken.

NOTES

Notes call attention to information that is especially significant to understanding and operating the equipment.

This document is based on information available at the time of its publication. While efforts have been made to ensure accuracy, the information contained herein does not cover all details or variations in hardware and software, nor does it provide for every possible contingency in connection with installation, operation, and maintenance. Features may be described herein that are not present in all hardware and software systems. GE Electrical Distribution & Control assumes no obligation of notice to holders of this document with respect to changes subsequently made.

GE Electrical Distribution & Control makes no representation or warranty, expressed, implied, or statutory, with respect to, and assumes no responsibility for the accuracy, completeness, sufficiency, or usefulness of the information contained herein. No warranties of merchantability or fitness for purpose shall apply.

Table of Contents**Chapter 1 – Product Description**

1-1 Introduction	1-1
1-2 Applications	1-1
1-3 Protection	1-1
1-4 Additional Features	1-4
Inputs	1-4
Outputs	1-4
Self-Tests	1-5
Frequency Tracking	1-5
Operating Data (Normal and Fault)	1-5
Local User-Machine Interface (UMI)	1-5
Remote Communications	1-5

Chapter 2 – Hardware Description & Specifications

2-1 Hardware Description	2-1
Case Assembly	2-1
Identification	2-1
Receiving and Handling	2-1
Mounting	2-1
Surge Ground Connections	2-1
2-2 Technical Specifications	2-1

Chapter 3 – System Interfaces

3-1 Front Panel	3-1
LEDs	3-1
Key Pad	3-1
3-2 Display Menus and Messages	3-2
Data Menus	3-2
Settings Menu	3-6
Test and Maintenance Menu	3-6
User Interface Examples	3-6
Flash Messages	3-7
Constant Messages	3-7
3-3 External Connections	3-7
Control Power	3-7
Chassis Ground	3-7
Current Inputs	3-8
Voltage Inputs	3-8
Output Contacts	3-8
Logic Control Inputs	3-9
RTD Inputs	3-9
Communication Port	3-9

Chapter 4 – Settings and Configurations

4-1 Introduction 4-1
4-2 Communication Settings 4-1
4-3 System Parameter Settings 4-4
4-4 Voltage Settings 4-6
4-5 Current Settings 4-7
4-6 Power Settings 4-12
4-7 Temperature Settings 4-14
4-8 Tripping and Alarm Options 4-15

Appendix A – DMP2 Protection System Settings A-1

Appendix B – DMP3 Protection System Settings B-1

List of Figures

1-1. Typical external connections to the DMP system.....	1-6
1-2. Typical external current and voltage connections to the DMP system.	1-8
2-1. Case and mounting dimensions for the DMP in a drawout case.....	2-2
2-2. Case and mounting dimensions for the DMP in a fixed vertical or horizontal case.	2-2
2-3. Input and output terminals on the rear of the drawout case.	2-3
2-4. Input and output terminals on the rear of the fixed horizontal and vertical cases.	2-3
3-1. DMP front panel.	3-1
3-2. Sequence of menu items for each category of the Data menu.	3-3
3-3. Sequence of menu items for each category of the Test and Maintenance menu.	3-6
4-1. Sequence of menu items for each category of the Settings menu.	4-2
4-2. Thermal overload protection characteristic curves for a cold motor and overload pickup of 105%	4-10
4-3. Thermal overload protection characteristic curves for a hot motor and overload pickup of 105%.	4-11
4-4. Characteristic curves for current unbalance protection.	4-13

1-1. Temperature-resistance values for RTDs used in the DMP system.	1-2
1-2. Input requirements for the possible control modes.	1-4
2-1. Electrical ratings of the DMP system.	2-4
2-2. DMP contact ratings.	2-5
2-3. DMP measured and calculated data accuracy ratings.	2-6
3-1. Menu items available in the Measured Data category.	3-4
3-2. Menu items available in the Calculated Data category.	3-4
3-3. Menu items available in the Logical Inputs and Contact Status category.	3-5
3-4. Menu items available in the Statistical Data category.	3-5
3-5. Menu items available in the Fault Data category.	3-5
3-6. Menu items available under the Test menu.	3-6
3-7. Flash messages appearing in response to an operator action.	3-8
3-8. Constant messages indicating a need for operator action.	3-8
4-1. Settings available in the Communication category.	4-1
4-2. Criteria for setting VT PRIMARY and VT SECONDARY in single- and wye-connected VT applications.	4-5
4-3. Settings available in the System Parameter category.	4-5
4-4. Settings available in the Voltage category.	4-7
4-5. Settings available in the Current category.	4-8
4-6. Settings available in the Power category.	4-12
4-7. Settings available in the Temperature category.	4-14
4-8. TRIP and ALARM setting limitations on voltage-dependent functions.	4-15
4-9. DMP protection functions and default settings for each tripping and alarming option. .	4-16

1-1 Introduction

The DMP is a microprocessor-based digital relay system that uses high-resolution waveform sampling of input signals to provide protection, control, and monitoring of three-phase motors. The following three families of DMP relays are available:

- DMP1 – Motor-protection relay system with voltage input and motor-control capabilities.
- DMP2 – Motor-protection relay system with voltage input.
- DMP3 – Basic motor-protection relay system.

The DMP catalog number system is illustrated inside the front cover.

The DMP2 and DMP3 relays are described in this book. The DMP1 relay is described in GEK-100686.

1-2 Applications

The DMP is a compact, protection-based digital system suitable for a range of applications, from low-voltage motor control centers associated with small industrial motors to the largest medium-voltage industrial process motors and utility power plant auxiliary motors in generating stations.

The DMP is primarily used for protection of an induction motor. Additional devices may be required if a DMP is used for synchronous motor protection and control.

For low-voltage applications (up to 750 V), the voltage input signal can be connected directly to the relay. Instrument transformers are used for higher voltage motors. The appropriate protection and control can be configured in the field to suit the specific application. A sampling frequency of 2 kHz provides excellent measurement accuracy.

The DMP system includes an RS-485 serial communication port, as well as multiple inputs and outputs to facilitate remote control and data transfer.

More detailed application considerations are described in this chapter and in *Chapter 4 – Settings and Configurations*.

Figures 1-1 and 1-2 illustrate typical external connections for the DMP system.

1-3 Protection

The following protection functions are included in the DMP system. Each of these functions can be individually configured to provide any combination of trip and alarm outputs. The ANSI/IEEE standard device numbers follow each function in parentheses.

Maximum Start Time (48)

This function provides protection against an incomplete start sequence by comparing the actual motor start time with the set maximum start time. In addition to motor protection, this function can provide protection to the autotransformer/starting reactor in a reduced-voltage motor controller.

Too Many Starts (66)

This function produces an output when the actual number of starts counted by the DMP within a dynamic time window of specified duration exceeds a set number.

Thermal Overload (49/51) and Locked Rotor Protection

A thermal model of the motor is incorporated in the DMP system to compute thermal capacity of the motor, based on the motor current and various parameters such as overload pickup, hot/cold ratio, stall time factor, speed switch input, and heating/cooling time factor. The relay computes the thermal capacity on a dynamic basis and is capable of providing a pretrip alarm (Thermal Level 1), in addition to the overload trip (Thermal Level 2) output.

The thermal overload protection function automatically adapts to faster operation, depending on the stall time factor setting and the speed switch input (if available), to provide locked-rotor protection (49S/51) during the motor start. A unique speed-switch-less logic is implemented in the DMP system to provide the same degree of locked-rotor protection when the speed switch input is not available.

Figure 4-2 and 4-3 contain characteristic curves of the thermal overload function. A reset characteristic is incorporated in this function to model cooling down of the motor. See *Chapter 4 – Settings and Configurations* for details.

Chapter 1 – Product Description

External RTD Interface (49R)

As many as 10 external RTDs can be connected to the DMP system. The RTDs may be either copper (10 Ω), platinum (100 Ω), or nickel (120 Ω) depending on the DMP model. Each of the 10 RTDs incorporates two levels of threshold setting, with a factory-programmed time delay of 2 seconds. Level 1 is intended for an alarm and Level 2 is intended for a trip. The DMP is designed for RTDs having the resistance parameters shown in Table 1-1.

° C	Resistance (ohms)		
	Copper	Platinum	Nickel
0	9.035	100.000	120.000
10	9.421	103.902	127.168
20	9.807	107.793	134.518
30	10.194	111.672	142.060
40	10.580	115.539	149.801
50	10.966	119.395	157.746
60	11.352	123.239	165.900
70	11.738	127.072	174.268
80	12.124	130.893	182.849
90	12.511	134.702	191.639
100	12.897	138.500	200.640
110	13.283	142.286	209.854
120	13.669	146.061	219.290
130	14.055	149.823	228.949
140	14.442	153.575	238.836
150	14.828	157.315	248.950
160	15.217	161.043	259.296
170	15.607	164.759	269.894
180	15.996	168.464	280.770
190	16.386	172.158	291.949
200	16.776	175.839	303.455

Table 1-1. Temperature-resistance values for RTDs used in the DMP system.

Overcurrent (51R/50)

Two levels of phase overcurrent protection are implemented, each with its own pickup and time delay settings.

- Level 1 can detect a jam or stall condition (51R) and is active only when the motor is running.
- Level 2 detects a short circuit (50) and is active whenever CURRENT INHIBIT is set to OFF. If a

motor contactor is not adequately rated for the available short circuit currents, CURRENT INHIBIT can prevent the contactor's opening when the short circuit current exceeds the CURRENT INHIBIT pickup setting.

Ground Fault Overcurrent (50G/50N)

Two levels of ground fault overcurrent protection are implemented, each with its own pickup and time delay settings. Level 1 provides an alarm function and Level 2 provides a trip function. Both levels are active whenever CURRENT INHIBIT is set to OFF.

If a motor contactor is not adequately rated for the available short circuit currents, CURRENT INHIBIT can prevent the contactor's opening when the fault current exceeds the CURRENT INHIBIT pickup setting.

Either a residual current circuit or a ground sensor current transformer (CT) circuit can provide the ground current input to the DMP. Figure 1-2 (A & B) illustrates typical connections.

Undercurrent (37)

Two levels of undercurrent protection are implemented, each with its own pickup and time delay settings. Level 1 provides an alarm function, Level 2 a trip function. Both levels are active when the motor is running and both can detect a loss-of-load condition.

The undercurrent function (or underpower, described later) can be used with a submersible pump, in which loss of prime can cause a motor to overheat and fail, or for a broken shaft or conveyor belt application.

Load Increase (51L)

The load increase protection function operates if the motor current increases above a set value for more than 5 seconds while the motor is running. This function is useful in cases in which a process may be damaged if a load increases above a certain level, such as in a paper mill, where refiner plates may contact unduly and damage each other.

An output contact can be configured to remove the load to the process long enough for recovery. With the function configured as auto-reset, the loading

can be automatically restarted when the condition clears.

Underpower (32L) [DMP2 only]

Two levels of underpower protection are implemented, each with its own pickup and time delay settings. Level 1 provides an alarm function, Level 2 a trip function. Both levels are active when the motor is running and both can detect a loss-of-load condition. Underpower protection is functionally equivalent to undercurrent protection, except that it is based on power, rather than current.

Unbalance Current (46)

Unbalanced currents can be caused by unbalanced voltages in the power system or by a blown fuse in the motor controller and can result in rotor overheating. This function computes the percent of unbalance current and has the time characteristic shown in Figure 4-4. Operation time is inversely proportional to the square of the unbalance current, with a minimum of 1 second. The two levels are set as follows:

- Level 2 trip is set by the customer to the maximum-allowable unbalance current. This function has a slow-reset characteristic to simulate the motor's cooling.
- Level 1 is automatically set at 50% of the level 2 setting, with a delay time of 1 second, and can be used as a pretrip alarm.

Undervoltage (27) [DMP2 only]

Power system problems can result in undervoltage conditions that cause increased motor currents. To anticipate motor overheating caused by these currents, the DMP2 undervoltage function operates when the average of the three line-to-line voltages decreases below a set value. The definite delay time is also set by the customer.

This function is active during the motor's start and run modes and can be used with either three-phase or single-phase voltage signal inputs. Figure 1-2 (C, D, E, & F) illustrates typical connections.

Overvoltage (59) [DMP2 only]

Power system problems can cause an overvoltage condition, resulting in excessive excitation current to

the motor. The DMP2 detects an overvoltage condition when the average of three line-to-line voltages increases above the overvoltage setting.

Two levels of overvoltage protection are implemented, with individual time delays.

- Level 1 incorporates a fixed factory-set delay of 1 second and is intended as an alarm.
- Level 2 is intended as a trip function, with pickup level and time delay set by the customer.

Overvoltage protection is active during the motor's start and run modes and can be used with either three-phase or single-phase voltage signal inputs. Figure 1-2 (C, D, E, & F) illustrates typical connections.

Phase Loss/Phase Sequence (47) [DMP2 only]

Phase loss protection is activated in the DMP2 when the difference in magnitudes of the highest and lowest line-to-line voltages exceeds 20% of the rated line voltage. Phase sequence protection operates when the DMP2 detects a reverse-voltage sequence. Both functions are implemented with factory-set delay times of 2 seconds.

External Protective Device Interface

Three contact inputs are provided to provide an interface with external protective devices, such as motor differential relays. These inputs are factory configured in fail-safe mode and will cause a trip or alarm when open.

Low Power Factor (55) [DMP2 only]

A combined load of an induction motor and any power factor correction connected to its terminals experiences a decrease in power factor if the correction fails. Also, the power factor of a running synchronous motor decreases in the lagging direction upon loss of field. The DMP2 provides an adjustable low lagging-power-factor threshold and adjustable time delay.

Abnormal Conditions

The following conditions monitored by the DMP can be configured to trip and/or alarm when an abnormality is detected.

- *Communications Port Failure* – A failure of the RS-485 serial link.

Chapter 1 – Product Description

- **Internal Failure** – A hardware failure detected during self-test.

In addition to the 10 RTDs mentioned earlier, there are 5 logical inputs (contacts) available. Table 1-2 contains functional descriptions of these inputs

1-4 Additional Features

Inputs

The DMP can be powered from either an ac or dc source, depending on the model.

The DMP accepts four current (three phase and one ground) and three voltage signal inputs. The ground current input can be derived from either residual current circuit connections or from a ground sensor CT, as shown in Figure 1-2 (A & B). Both 1 ampere and 5 ampere current input terminals are available to match the CT secondary rating.

Voltage inputs to the DMP are provided on models DMP1 and DMP2. Figure 1-2 (C, D, E, & F) show different connections for the available voltage input signals to the DMP2. Three-phase, three- or four-wire voltage signals, derived from delta- or wye-connected voltage transformers (VTs), shown in Figure 1-2 (C & D), can be connected to the DMP for proper operation of all the voltage-dependent functions. For low-voltage applications (up to 750 V), the motor voltage can be connected directly to the DMP, as shown in Figure 1-2 (F).

If the three-phase voltage signal is *not* connected to the DMP2, the voltage-dependent protection functions—Phase Loss/Phase Sequence (47), Low Power Factor (55), and Underpower (32L)—are unavailable and must be disabled. (See *Chapter 4 – Settings and Configurations* for details.) In addition, some measured data, such as volts, watts, vars, and power factor, are also unavailable.

Figure 1-2 (E) shows the recommended connection when only a single-phase voltage signal is available. This connection allows use of the protection functions Undervoltage (27), including Undervoltage Start Prevent, and Overvoltage (59). The Frequency Tracking feature, described later, is also available. If *no* voltage signal is available, the Undervoltage and Overvoltage functions must also be disabled. (See *Chapter 4 – Settings and Configurations* for details.)

No. of Inputs	Description of Input
1	Authorized key-switch input for security against unauthorized setting changes and DMP resetting.
1	Speed-switch contact input. Provides indication of rotation during motor starting, used by the DMP to determine the appropriate overload characteristic during startup. See <i>Chapter 4 – Settings and Configurations</i> for a unique speed-switchless logic to supplement the speed-switch input.
3	External protective device “fail-safe” contact inputs (External Fault 1, 2, 3).

Table 1-2. DMP system logic inputs.

Outputs

There are four output relays (A, B, C, and D), each with one trip-rated Form C contact. The available configurations for each relay are described below.

Relay A – This relay is a dedicated trip output for the Thermal Level 2 function.

Relay B – This relay is a dedicated trip output for the Ground Fault Level 2 function.

Relay C – This output can be configured by the customer to either or the following. Refer to *Chapter 4 – Settings and Configurations* for details.

- An alarm (fail-safe).
- A slave to Relay A or B.

Relay D – This output can be configured by the customer as one of the following. Refer to *Chapter 4 – Settings and Configurations* for details.

- A trip (fail-safe or nonfail-safe).
- A slave to Relay A or B.

Self-Tests

The DMP performs extensive self-tests during power-up and on a manual Self Test command from the Test/Maintenance Options menu.

The DMP also performs continuous background self-tests, as a lower priority than the protection and control functions. Any unsuccessful self-test is reported

as Internal Failure and be configured as an alarm or trip. Refer to *Chapter 4 – Settings and Configurations* for details.

Frequency Tracking

The DMP automatically tracks power system frequency over the range of 45–65 Hz to compensate for any deviation from the nominal frequency of 50 to 60 Hz. This feature maintains the measurement accuracy of the analog inputs and the sensitivities of the protection functions over the range of power system frequencies. The motor voltage (single or three phase) is required as an input for proper operation of this feature. If no ac voltage is connected, the DMP assumes that the actual frequency is the same as the nominal power system frequency.

Operating Data (Normal and Fault)

The DMP can report a variety of normal and fault data related to motor operation. These data are characterized as Measured, Calculated, Statistical, or Fault. The status of the contact inputs can also be reported. Refer to *Chapter 3 – System Interface* for details.

Local User-Machine Interface (UMI)

The local UMI includes a key pad, back-lit liquid crystal display (LCD), and nine LED monitors for entering settings, displaying present metering data, viewing fault target information, and accessing stored data. The UMI is described in *Chapter 3 – System Interfaces*.

Remote Communications

The standard RS-485 port can be used for communication between the DMP and a remote PC. The serial port allows remote motor control, setting changes, and viewing of any data stored in the DMP. Refer to *Chapter 3 – System Interfaces* for details.

Chapter 1 – Product Description

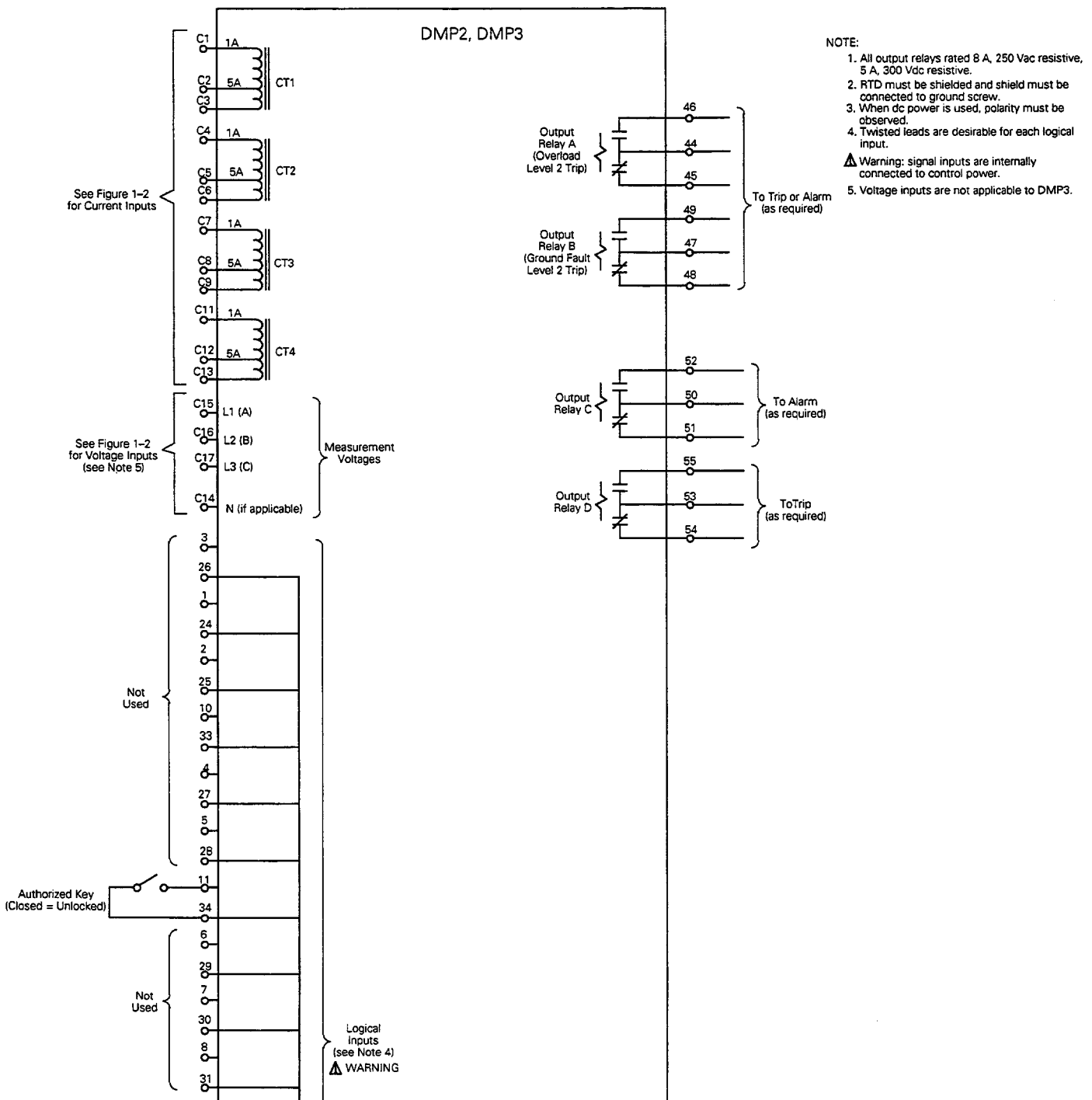

Figure 1-1. Typical external connections to the DMP system.

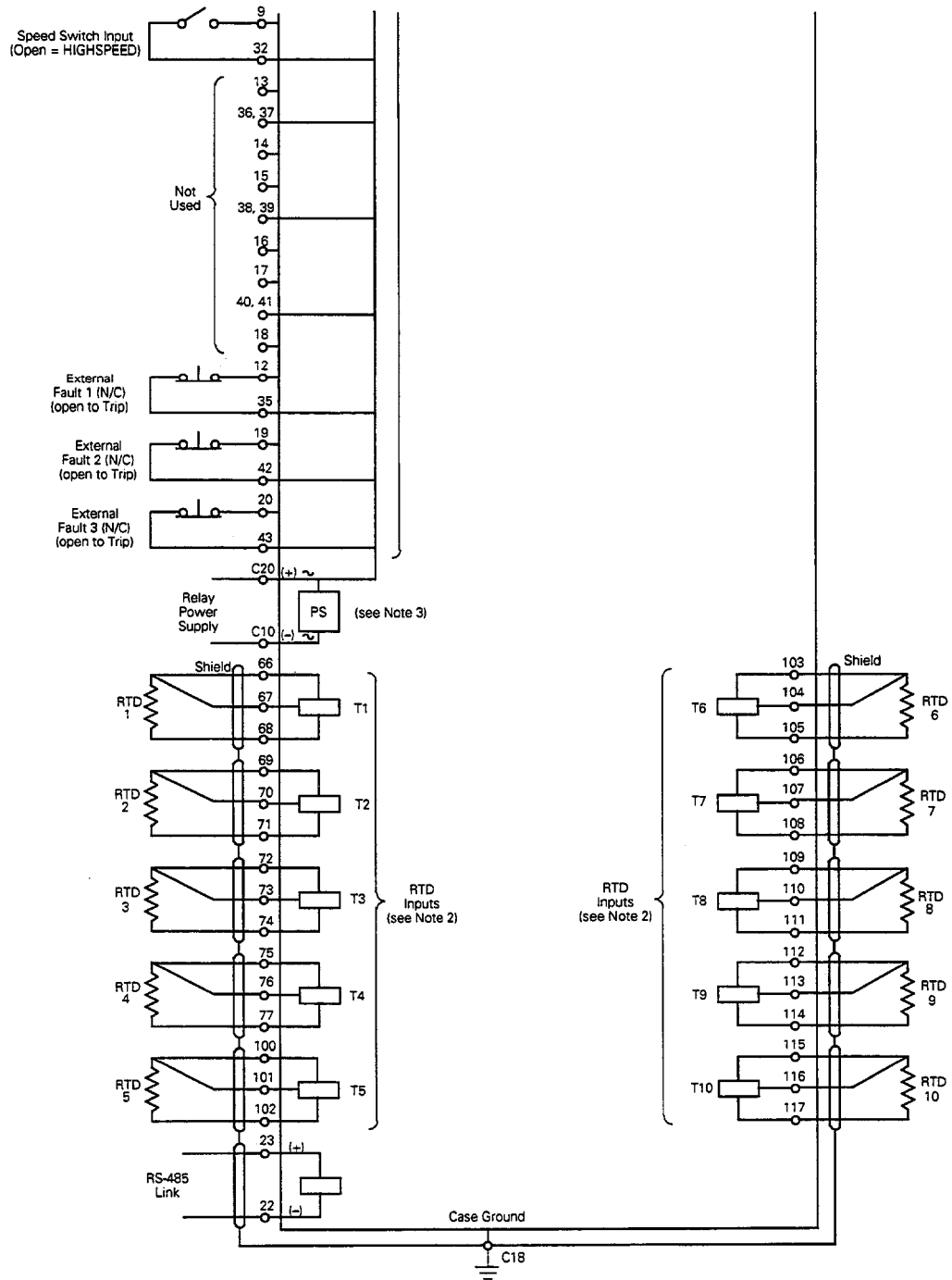

Figure 1-1. Typical external connections to the DMP system (cont.).

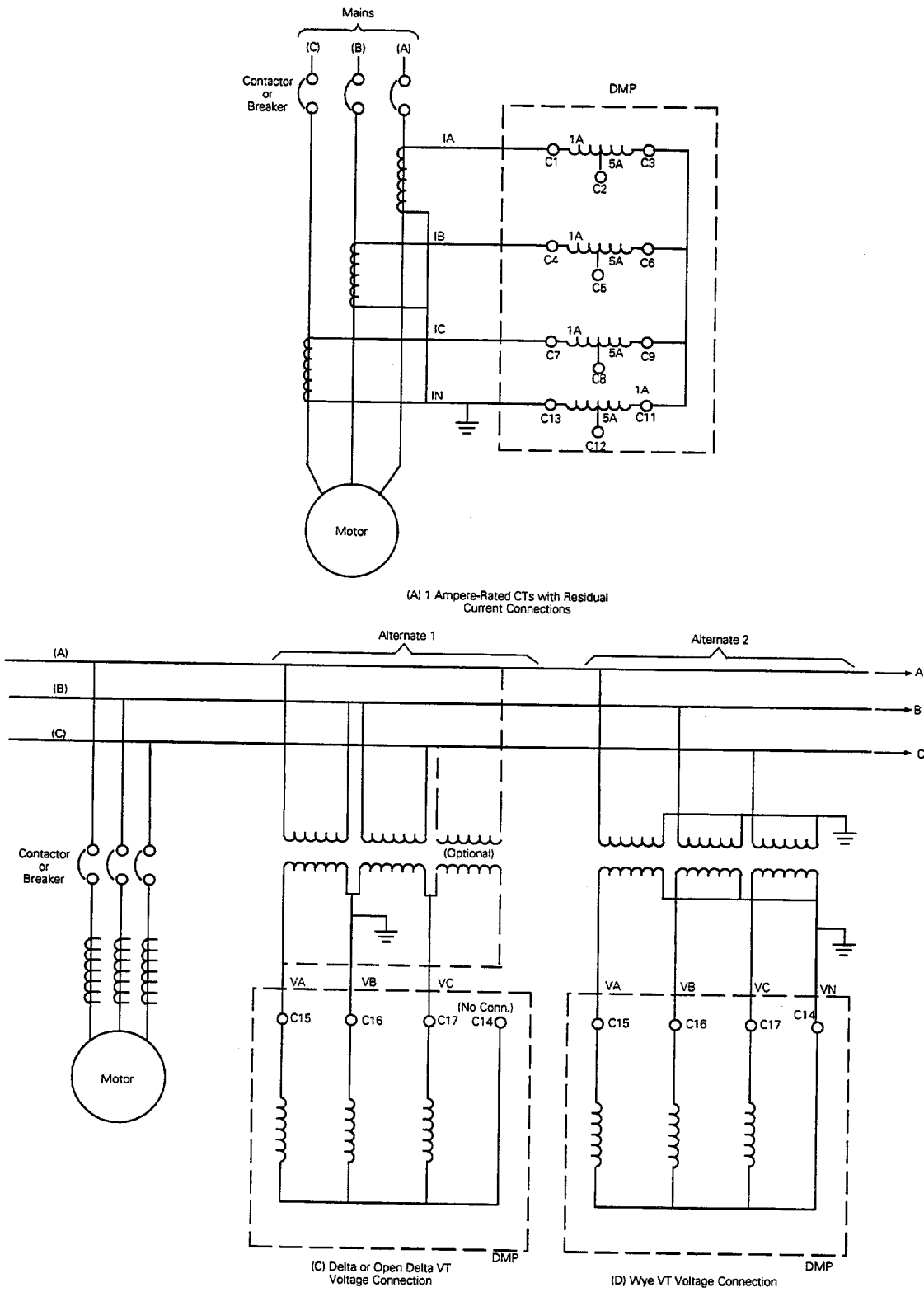

Figure 1-2. Typical external current and voltage connections to the DMP system.

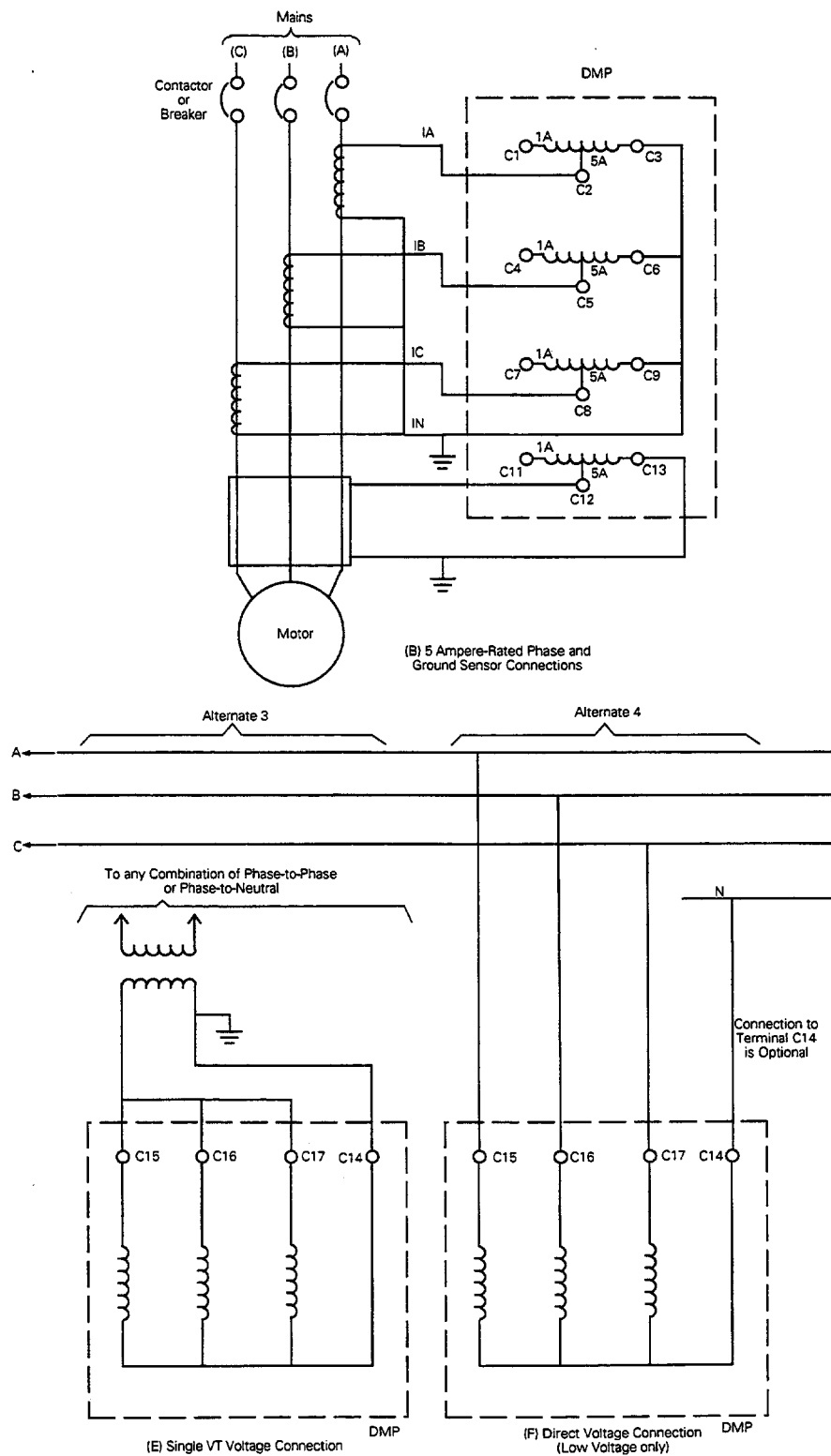

Figure 1-2. Typical external current and voltage connections to the DMP system (cont.).



Chapter 2 – Hardware Description & Specifications

This chapter contains descriptions of the DMP hardware and the DMP system technical specifications.

2-1 Hardware Description**Case Assembly**

The DMP is available with three different cases: drawout, fixed vertical, and fixed horizontal. These are described below.

Drawout Case

The drawout case is an M-2 case with a cutout for accessing the control inputs, RTDs, and trip and alarm contacts. The dimensions for panel and semiflush mounting are shown in Figure 2-1.

Fixed Vertical and Horizontal Cases

The fixed vertical and horizontal cases have the same dimensions, as shown in Figure 2-2. The longest dimension determines whether the mounting is vertical or horizontal. The fixed vertical and horizontal cases must be unwired before the DMP can be removed from the system.

Identification

The DMP model number is located on the front cover. See the *Getting Started* section to determine the configuration of your unit.

Terminals for input and output are labeled on the rear of the case. These are illustrated in Figure 2-3 for the drawout case and Figure 2-4 for the fixed vertical and horizontal cases.

Receiving and Handling

The equipment should be unpacked and examined for shipping damage immediately upon receipt. If damage is evident, file a claim at once with the shipping company and notify the nearest ED&C sales office.

If the equipment is not to be installed immediately, store it indoors in a dry location that is protected from dust, metal chips, and severe atmospheric conditions.

Mounting

The DMP can be mounted in a standard rack. For mounting dimensions, refer to Figure 2-1 for a drawout case or Figure 2-2 for a fixed case.

Surge Ground Connections

Terminal C18 on the rear of the DMP is provided for surge ground connections. This terminal is also for connecting the shields of the RTDs and the communication cable. The drawout case has an additional surge ground stud on the rear of the case. #10 AWG wire should be used to connect the DMP to ground.

2-2 Technical Specifications

Table 2-1 contains the electrical ratings for the DMP, Table 2-2 contains contact ratings, and Table 2-3 contains accuracies for the measured and calculated parameters.

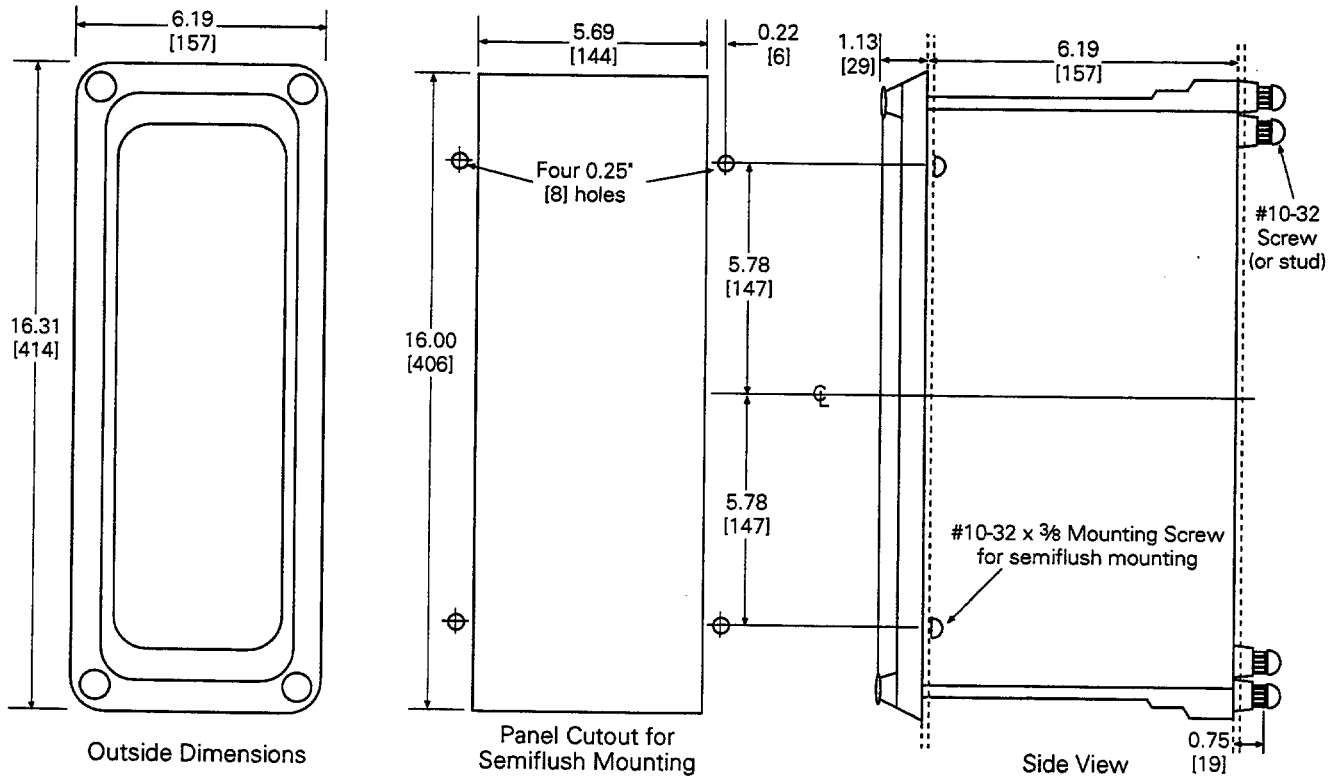

Figure 2-1. Case and mounting dimensions in inches [mm] for the DMP in a drawout case.

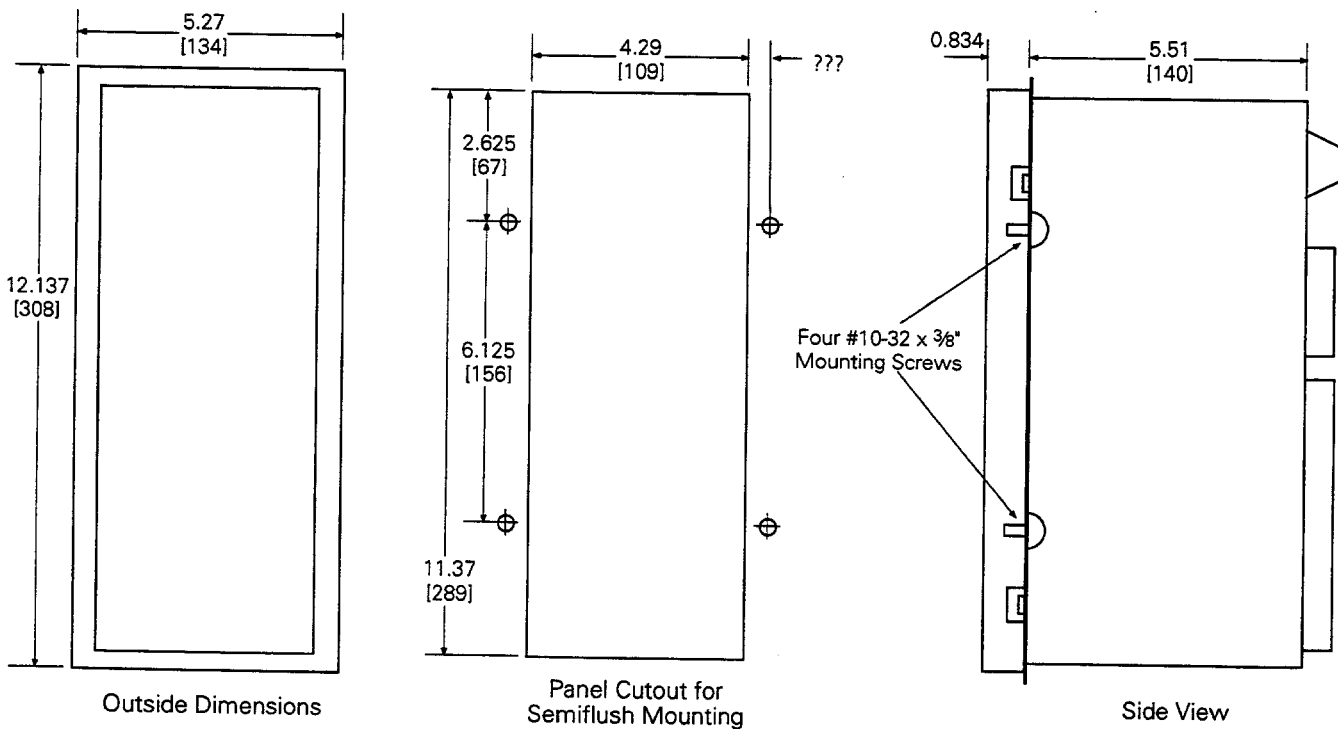

Figure 2-2. Case and mounting dimensions in inches [mm] for the DMP in a fixed vertical or horizontal case.

Chapter 2 – Hardware Description & Specifications

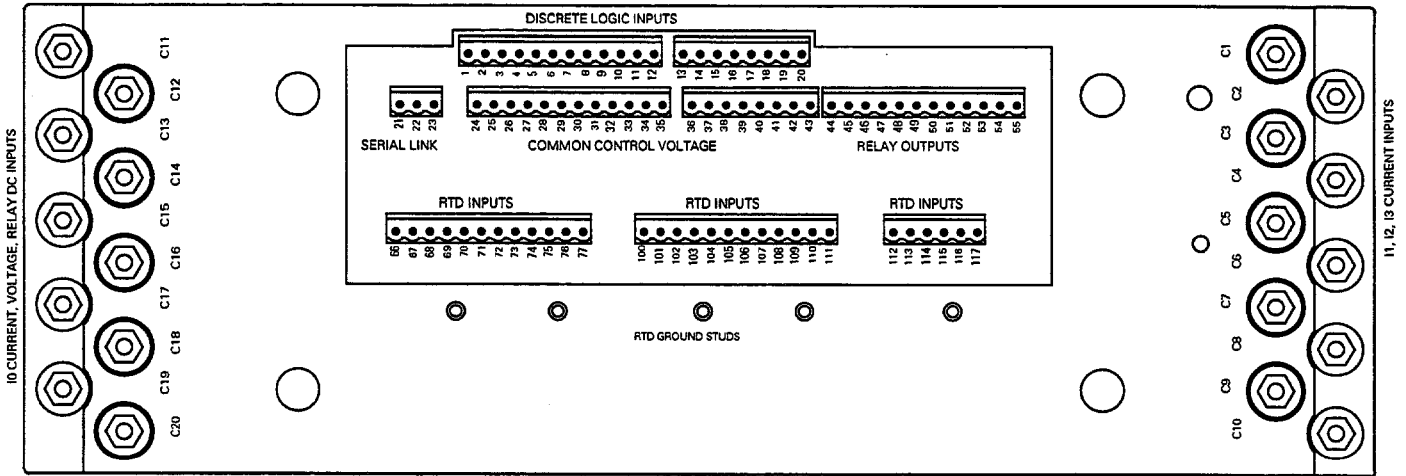

Figure 2-3. Input and output terminals on the rear of the drawout case.

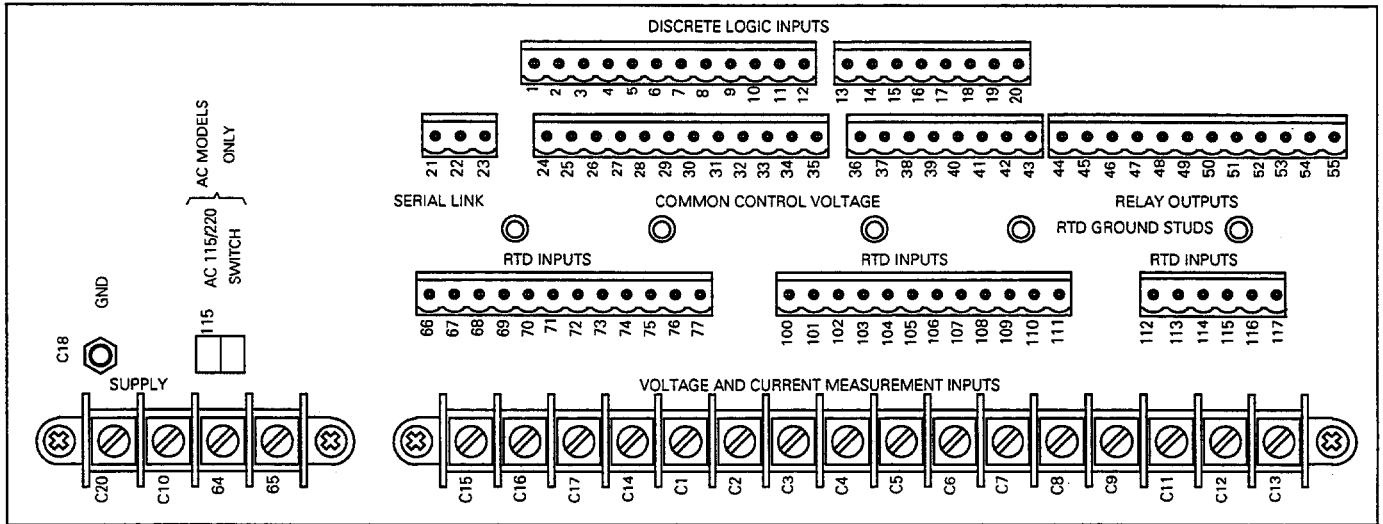

Figure 2-4. Input and output terminals on the rear of the fixed horizontal and vertical cases.

Parameter	Rating
Frequency	50 or 60 Hz, software selectable
Rated current	1 ampere 5 ampere with 5 A tap
Rated voltage *	50–750 Vac phase-to-phase
Maximum permissible current, 1 A rated CT Continuous 2 sec 1 sec	3X rated current 30X rated current 50X rated current
Maximum permissible current, 5 A rated CT Continuous 2 sec 1 sec	3X rated current 30X rated current 100X rated current
Maximum permissible ac voltage *	750 Vac phase to phase 380 Vac phase to neutral
Burden – phase & ground per CT, 1 A rated CT Applied current VA Input impedance	1 A ≤ 0.1 VA ≤ 100 mΩ
Burden – phase & ground per CT, 5 A rated CT Applied current VA Input impedance	5 A ≤ 0.5 VA ≤ 20 mΩ
dc power supply 24–48 Vdc 125–250 Vdc Burden	range: 19–60 Vdc range: 85–300 Vdc ≤ 20 VA
ac power supply Switch at 115 Vac Switch at 220 Vac Burden	80–135 Vac 160–270 Vac ≤ 20 VA
Impulse	Meets IEC 255–4 (1976) & Amend #1 (1979) Meets IEC 255–5 (1977) 5 kV common-mode test 5 kV transverse-mode test
Dielectric strength	2500 Vac for 1 min. common mode, between ground and – current inputs – voltage inputs – auxiliary power supply inputs – control terminals 1.5 Vac for 1 min. transverse mode, between each of the above circuits

* Not applicable with DMP3.

Table 2–1. Electrical ratings of the DMP system.

Chapter 2 – Hardware Description & Specifications

Parameter	Rating
Dielectric strength	2500 Vac for 1 min. common mode, between ground and - current inputs - voltage inputs - auxiliary power supply inputs - control terminals 1.5 Vac for 1 min. transverse mode, between each of the above circuits
Surge withstand Oscillatory Fast transient In accordance with:	2.5 kV peak 4 kV crest voltage ANSI C37.90.1 (1990), IEC 255-4 (1976) & Amend #1 (1979) Class III, IEC 255-22-2 (1988) Class III
Radio frequency interference	In accordance with EMI standard ANSI C37.90.2
Ambient temperature range	Operating: -20° to +65° C Display: -20° to +60° C
Humidity	95% without condensation

Table 2-1. Electrical ratings of the DMP system (cont.).

Parameter	Rating
Closing	Close and conduct to a maximum of 30 A for tripping duty (5 cycles) at control voltages to 300 Vdc.
Continuous	5 A at 300 Vdc maximum
Interrupting	ac inductive load PF = 0.4 dc resistive load L/R = 40 ms
ac inductive load	120 Vac, 8 A 240 Vac, 7.5 A
ac resistive load	120 Vac, 10 A 240 Vac, 8 A
dc inductive load	48 Vdc, 0.7 A 125 Vdc, 0.3 A
dc resistive load	48 Vdc, 1 A 125 Vdc, 0.4 A

Table 2-2. DMP contact ratings.

Chapter 2 – Hardware Description & Specifications

Parameter	Rating
Voltage Method Accuracy	True rms, 0.5 ms sample time ±1%
Current Method Accuracy	True rms, 0.5 ms sample time ±1.5% for 0.9–1.5 X CT primary amps setting ±5% above 1.5 X primary amps setting ±3% + 0.02 X primary amps setting below 0.9 X CT setting
Power * Method Range Full scale Accuracy	Total of three phases 0–65 MW 65 MW ±3%
Reactive power * Method Range Full scale Accuracy	Total of three phases 0–65 MVARs 65 MVARs ±3%
Power factor * Method Range Full scale Accuracy	Total of three phases 0–1 1 ± 3%
RTD inputs Range Accuracy Time delay Maximum wire resistance RTD types	10 three-wire RTDs 0–200° C ±3% of resistance 2.0 ±1.0 s 25% of RTD at 0° C 10 Ω Cu, 100 Ω Pt–120 Ω Ni
Thermal overload curves Fault-time accuracy Threshold current level	±1 s up to 10 s ±2% above 10 s Overload setting ±1.5%
Unbalanced trip & alarm Method Alarm Unbalanced alarm threshold level Fixed delay time Trip Unbalanced alarm threshold level Fixed delay time	$\text{Unbalance} = 100 \frac{I_{\max} - I_{\min}}{I_r} [\%]$ $I_{\max} = \text{max of phase currents}$ $I_{\min} = \text{min of phase currents}$ $I_r = \text{Larger of } (I_{\max}, \text{ motor FLC})$ (I _r used to prevent unnecessary tripping at low currents)
Fault time delay accuracy	±0.5 s or 2% of setting, whichever is greater
Exceptions to above Overcurrent level 2 (short) Ground fault trip	60 ms ±20 ms when adjusted to 0 –0.1/+0.2 s for delay < 1 s –0.1/+0.2 s for delay < 1 s

* Not applicable with DMP3.

Table 2–3. DMP measured and calculated data accuracy ratings.

This chapter contains descriptions of all external interfaces to the DMP system.

3-1 Front Panel

The DMP front panel, shown in Figure 3-1, encompasses nine LEDs, a two-line by 16-character back-lit LCD, and nine keys.

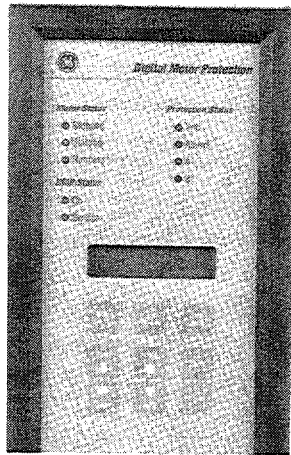

Figure 3-1. DMP front panel.

LEDs

The LEDs indicate the DMP, motor, and protection status. The DMP makes logical decisions based on the motor's input parameters.

Motor Status LEDs

STOPPED – This LED lights when a TRIP condition is detected or when the motor's FLC (full-load current) drops below 10% of the FLC setting.

STARTING – This LED lights when the motor current exceeds 115% of FLC.

RUNNING – This LED lights when the motor has completed the starting process. This occurs when the average motor current falls below 115% of FLC.

Protection Status LEDs

A – This LED lights when relay A is energized. This relay indicates a Thermal Level 2 trip.

B – This LED lights when relay B is energized. This relay indicates a Ground Fault Level 2 trip.

ALARM – This LED lights when the DMP senses a programmed alarm condition. If the fault sensed by the DMP disappears, the LED remains lit until the DMP is reset.

TRIP – This LED lights when the relay senses a programmed trip condition. If the fault sensed by the DMP disappears, the LED remains lit until the DMP is reset.

DMP Status LEDs

SERVICE – This LED lights when the DMP self-test determines that it is not functioning properly. Contact your local ED&C sales office to return the DMP for service.

ON – This LED lights when the DMP is energized.

Key Pad

The DMP's key pad allows you to change DMP parameter settings by scrolling through two levels of screens, which appear on the LCD. To view the top level press the SET MENUS, DATA MENUS, or TEST MENUS key. Each of these menus has a number of categories that are displayed by pressing the appropriate menu key.

To scroll through the items in a menu category, press the ITEM ↑ or ITEM ↓ key. You can jump to the top level of the current menu or to a different menu at any time by pressing the appropriate menu key.

Any of the settings displayed by the SET MENUS key can be changed by pressing the VALUE ↑ or VALUE ↓ key. After changing a setting, press the STORE key to save the change. If you change to a different menu category before storing a changed setting, it will be lost. You can, however, change multiple settings within the same menu category, then press STORE once before leaving that category.

The RESET key resets the DMP. Pressing the RESET key twice within one second resets the thermal capacity. Thermal capacity can only be reset on the front panel.

Top-Level Screen Keys

DATA MENUS – This key scrolls the display through the Data menu categories.

Chapter 3 – System Interfaces

SET MENU – This key scrolls the display through the Settings menu categories.

TEST MENU – This key scrolls the display through the Test menu categories.

Sublevel Screen Keys

ITEM ↑ and ITEM ↓ – These keys advance the display in the selected sublevel category.

VALUE ↑ and VALUE ↓ – These keys change the setting value of the item currently displayed.

Keys Usable on All Levels

STORE – This key stores changed settings in non-volatile memory. You must store a changed setting before moving to another level. For example, if you change drive number and baud rate in the Communications Settings menu, press STORE before moving to another Settings page, such as Voltage Settings.

RESET – This key resets the DMP or, if pressed twice within one second, resets the thermal capacity. A DMP RESET is only enabled when the LOCAL/REMOTE logical input is open. A RESET is not accepted during an effective START command. A thermal capacity reset is enabled whenever the AUTHORIZED key is closed.

3-2 Display Menus and Messages

This section describes the Data, Settings, and Test menus and other messages that may appear on the display.

Data Menus

The categories available under the Data menu are Measured Data, Calculated Data, Logical Inputs and Contact Status, Statistical Data, and Fault Data. Figure 3-2 shows the sequence of menu items under each category of the Data menu. The menu items in each category are described in Tables 3-1, 3-2, 3-3, 3-4, and 3-5.

NOTE: Any menu item can be displayed continuously. Press the STORE key when the desired item is displayed. DATA STORED OK will momentarily appear on the display, then the selected data item will appear whenever the display is not being used for another function.

NOTE: Tout item du menu peut être configuré pour s'afficher de manière continue. Appuyer sur la touche STORE lorsque l'item désiré est affiché. Les mots DATA STORED OK apparaîtront momentanément à l'affichage, puis les données de l'item sélectionné apparaîtront lorsque l'affichage n'est pas utilisé pour une autre fonction.

Chapter 3 – System Interfaces

Display Item	Description
UP1 UP2 UP3 *	Measured phase-neutral voltages.
UL12 UL23 UL31 *	Measured line-line voltages.
I1 I2 I3	Measured motor line currents.
GROUND CURRENT	Measured ground current.
POWER *	Active power in kW.
REACTIVE POWER *	Reactive power in kVARs.
POWER FACTOR *	Leading or lagging power factor.
T1 T2 T3	RTD 1-3 temperatures in °C.
T4 T5 T6	RTD 4-6 temperatures in °C.
T7 T8 T9	RTD 7-9 temperatures in °C.
T10	RTD 10 temperature in °C.

* Not applicable with DMP3.

Table 3-1. Menu items available in the Measured Data category.

Display Item	Description
MOTOR LOAD CURRENT	Motor current as a percentage of MOTOR FLC.
THERMAL CAPACITY	Thermal capacity register value. Calculated as the ratio of the current over the overload setting I_{OL} .
TIME TO TRIP O/L	Time to trip when the motor current is above overload pickup. The actual time depends on the overload, t_{6x} , and HOT/COLD ratio settings.
TIME TO START	Expected time to start. After an OVERLOAD trip, the expected time for the thermal capacity to decrease to 50% of maximum allowed. The actual time depends on the cool time factor. After TOO MANY STARTS trip, the maximum value of TIME TO START equals START INHIBIT time.
UNBALANCED CURRENT	Difference between the max. and min. of the three motor line currents, related to the larger of the max. line current and MOTOR FLC.

Table 3-2. Menu items available in the Calculated Data category.

Display Item	Description
SPEED SWITCH	Speed Switch status: terminals 32 & 9 Input OPEN: motor turning at high speed. Input CLOSED: motor turning at low speed. Input should be OPEN if Speed Switch is not used.
AUTHORIZED KEY	Authorized Key status: terminals 34 & 11 (N/O) Input CLOSED: enables Setting changes. Thermal Capacity reset. Run self-test. Store default settings. Reset and store statistical data. Input OPEN: prevents above actions.
EXTERNAL FAULT 1	External Fault 1 status: terminals 35 & 12 (N/C) Input OPEN: alarm or trip as selected in alarm & trip options. Input CLOSED: run enable. If input is unused, disable External Fault 1.
EXTERNAL FAULT 2	External Fault 2 status: terminals 42 & 19 (N/C) Input OPEN: alarm or trip as selected in alarm & trip options. Input CLOSED: run enable. If input is unused, disable External Fault 2.
EXTERNAL FAULT 3	External Fault 3 status: terminals 43 & 20 (N/C) Input OPEN: alarm or trip as selected in alarm & trip options. Input CLOSED: run enable. If input is unused, disable External Fault 3.

Table 3-3. Menu items available in the Logical Inputs and Contact Status category (cont.).

Display Item	Description
TOTAL RUN TIME	Total run time since last reset of statistical data.
TOTAL # OF STARTS	Total number of starts since last reset of statistical data.
TOTAL # OF TRIPS	Total number of trips since last reset of statistical data.
LAST START PERIOD	Last start time duration. The time measured between a START command and when the current drops below 115% of I _{FL} .
LAST START MAX I	The maximum current of the three phases at the last start.

Table 3-4. Menu items available in the Statistical Data category.

Display Item	Description
LAST TRIP	The last active trip. Example: GND FAULT LVL 2 TRIP
LAST ALARM	The last active alarm. Example: EXTERNAL FAULT 1 ALARM
TRIP I1, I2, I3	Phase-phase current values at the last trip.
TRIP GND CURRENT	Ground current at the last trip.
TRIP UP1, UP2, UP3 *	Phase voltages at the last trip.

* Not applicable with DMP3.

Table 3-5. Menu items available in the Fault Data category.

Chapter 3 – System Interfaces

Settings Menu

The categories available in the Settings Menu are Communications, System Parameters, Voltage, Current, Power, Temperature, and Trip and Alarm Options. The range of settings and default values for each item are described in *Chapter 4 – Settings and Configurations*.

Test and Maintenance Menu

The sequence of key presses and menu items available under the Test and Maintenance menu is illustrated in Figure 3-3. The individual menu items are described in Table 3-6.

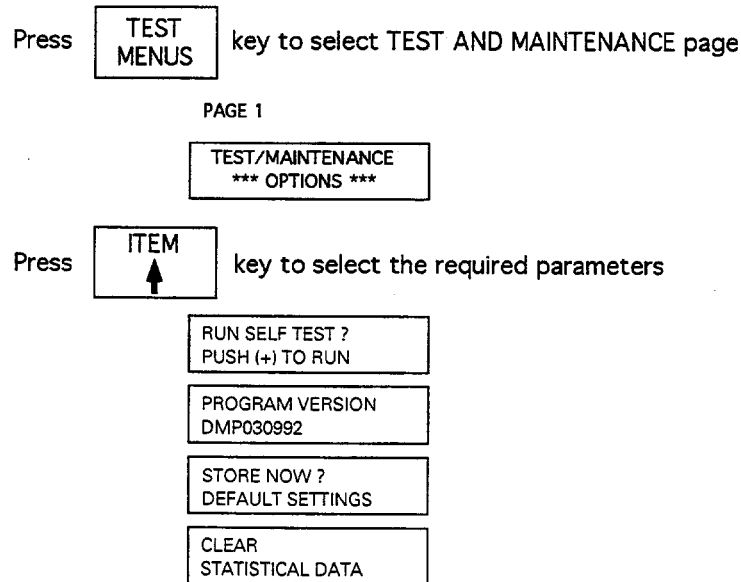

Figure 3-3. Sequence of menu items for each category of the Test and Maintenance menu.

Display Item	Description
RUN SELF TEST	Press the VALUE ↑ key to run the built-in self-test.
PROGRAM VERSION	Displays the DMP program version in MM/DD/YY format.
STORE DEFAULT SETTINGS NOW?	Press the STORE and SET DATA keys simultaneously to store all default settings.
CLEAR STATISTICAL DATA	Press the DATA MENU and STATISTICAL DATA RESET keys simultaneously to reset Statistical Data and Fault Data to zero.

Table 3-6. Menu items available under the Test menu.

User Interface Examples

This section contains examples of using the key pad to view data and change DMP configuration settings.

Viewing Data

This example describes how to display the thermal capacity.

1. Press the DATA MENUS key to scroll through the Data menu until

CALCULATED DATA

appears on the display.

2. Press the ITEM ↑ or ITEM ↓ key to scroll through the calculated data items until

```

THERMAL CAPACITY
XXX% OF CAPACITY
    
```

appears on the display.

Changing a Parameter Setting

This example describes how to change the value of a DMP voltage setting.

1. Press the SET MENUS key to scroll through the Settings menu until

```

VOLTAGE SETTINGS
    
```

appears on the display.

2. Press the ITEM ↑ or ITEM ↓ key to scroll through the voltage settings until

```

O/U LEVEL 1
115% OF Un
    
```

appears on the display.

3. Press the VALUE ↓ key until the setting changes to

```

O/U LEVEL 1
105% OF Un
    
```

4. Press the STORE key to save the new setting. The display then momentarily contains

```

DATA STORED OK
    
```

to verify the change.

NOTE: Be sure to press STORE after changing a setting and before continuing to a different menu, otherwise the change will not be retained.

NOTE: Assurez-vous d'appuyer sur STORE après un changement de réglage et avant de continuer dans un menu différent, sinon le changement ne sera pas mémorisé.

Flash Messages

Flash messages are notifications that appear on the display for one second, in response to an operator action, after which the display returns to the previous message. Flash messages either confirm an

activation of the requested operation or indicate the reason why it was not completed.

The list of available flash messages and their meanings appears in Table 3-7.

Constant Messages

Constant messages are notifications because of a problem requiring operator attention. The list of available constant messages and their meanings appears in Table 3-8.

3-3 External Connections

This sections contains descriptions of the input and output connections made on the rear of the DMP case. Figure 1-1 shows all the available inputs and outputs in a typical external connection configuration.

Control Power

Connect the control power source to terminals C20 (+) and C19 (-). The control power inputs accept up to #10 AWG wire. The DMP must be grounded before power is applied.

The DMP can be ordered to operate with any of three different supply voltages: 24-48 Vdc, 125-250 Vdc, and 110 or 120 Vac (selected by a rear-panel switch). Check the DMP name plate to ensure that the proper voltage is applied. The DMP has an internal 0.5 A fuse to protect the control power supply.

The DMP will remember motor information if control power is lost. Statistical, Calculated, and Fault data and Settings are stored in nonvolatile memory and are not affected by loss of power.

Chassis Ground

The ground stud on the rear of the DMP case is connected to the RTD shields, the RS-485 shield, and the DMP chassis. Connect the ground stud to system ground with #12 AWG wire before connecting control power or attempting to operate the DMP.

Display Item	Description
DATA SAVED OK	Displayed after a new setting is successfully saved following a STORE key press.
STORAGE ERROR	The new setting was not successfully stored.
DMP CHECK SUM ERROR	Displayed after power up if the nonvolatile memory parameter check sum does not match the previous value.
UNAUTHORIZED ACCESS	A parameter change, store, or reset was attempted when the authorized key was open.
RESET THERMAL CAPACITY??	Indicates that a second press within 1 second will reset the thermal capacity to zero.
THERMAL CAPACITY RESET PERFORMED	Displayed after a successful reset of the thermal capacity.
UNABLE TO START TRIP	The motor could not be started because a trip was activated.
UNABLE TO START CHECK SYSTEM	The motor could not be started; check the system.
SELF TEST PASSED	The DMP self-test passed.
SELF TEST FAILED	The DMP self-test failed.

Table 3-7. Flash messages appearing in response to an operator action.

Display Item	Description
ALARM	Displayed when an alarm condition has occurred. The second display line indicates the type of alarm.
TRIP	Displayed when a trip condition has occurred. The second display line indicates the type of trip.

Table 3-8. Constant messages indicating a need for operator action.

Current Inputs

The DMP has inputs for three or four external CTs, connected as shown in Figure 1-2. Each phase consists of a 1 A (nominal) input, a 5 A (nominal) tap, and common. The terminals accept up to #10 AWG wire. See Table 2-1 for the maximum permissible short-term current levels.

Voltage Inputs

(Not applicable with DMP3.) The DMP2 has three phase-voltage inputs and a neutral terminal for connection to three- or four-wire systems. The voltage inputs can be connected to external VTs in four ways: open delta, delta, wye, and single VT, as shown in Figure 1-2.

Output Contacts

The DMP contains four output relays, each having one N/C and one N/O contact. All contacts are rated at 8 A, 250 Vac resistive, and 1800 VA inductive. The contacts are accessible through a disconnectable connector on the rear of the DMP. See Table 2-2 for the contact technical specifications.

Relay A

Relay A functions as a Thermal Level 2 trip output. When the relay is closed, front-panel LED A is lit. Relay A's N/O contacts are available at terminals 44 and 46, the N/C contacts at terminals 44 and 45.

Relay B

Relay B functions as a Ground Fault Level 2 trip output. When the relay is closed, front-panel LED B is lit. Relay B's N/O contacts are available at ter-

minals 47 and 49, the N/C contacts at terminals 47 and 48.

Relay C

Relay C functions as an auxiliary relay that can be configured as one of the following (Settings Menu – System Parameters):

- Alarm relay with fail-safe logic.
- Slave relay for Contactor A.
- Slave relay for Contactor B.

Relay C is not automatically configured. When the relay is closed, the front-panel ALARM LED is lit. Relay C's N/O contacts are available at terminals 50 and 52, the N/C contacts at terminals 50 and 51.

If Relay C is enabled to alarm, the relay contacts are reset after an alarm only when the alarm condition reverts to normal and a Panel or PLC RESET is sent. Panel RESET and PLC RESET are enabled at the Settings Menu – Tripping and Alarm.

Relay D

Relay D functions as an auxiliary relay that can be configured as one of the following (Settings Menu – System Parameters):

- Trip relay.
- Trip relay with fail-safe logic.
- Slave relay for Contactor A.
- Slave relay for Contactor B.

Relay D is not automatically configured. When the relay is closed, the front-panel TRIP LED is lit. Relay D's N/O contacts are available at terminals 53 and 55, the N/C contacts at terminals 53 and 54.

If Relay D is enabled to trip, the relay contacts are reset after a trip only when the trip condition reverts to normal and a Panel or PLC RESET is sent. Panel RESET and PLC RESET are enabled at the Settings Menu – Tripping and Alarm.

Logic Control Inputs

The DMP has four logic inputs internally connected to control power. The maximum permissible resistance across these terminals is 3 k Ω . Long leads should be twisted to reduce noise and common-mode voltages.

The logic inputs communicate information to the DMP through switches, relay contacts, or application of control voltage. Since the inputs are connected to control voltage, the DMP can also receive an input from another power source with the same rating as the DMP's power source. The logic input voltage to an ac-powered DMP must be the same phase as the DMP supply.

RTD Inputs

The DMP has 10 RTD inputs, each of which can accept a 10 Ω copper or 100 Ω platinum/120 Ω nickel RTD, depending on the DMP model (see the Getting Started page for the appropriate catalog number). An RTD must be connected to the DMP with a shielded three-wire cable whose resistance is no more than 25% of the RTD resistance. All RTD cable shields must be connected to the rear-panel ground studs. All RTD temperatures may be viewed on the front-panel display.

Communication Port

Communications through the rear-panel RS-485 port can perform the following:

- Read actual input parameters.
- Read all parameter settings.
- Modify all parameter settings except communications.
- Reset a fault.

A serial link RESET is always enabled, unlike a Panel RESET or PLC RESET. Thermal Capacity can only be reset from the front panel.

A shielded, twisted-pair cable must be used to connect the DMP to the communication system. Connect the shield to the rear-panel ground stud.

CAUTION Ensure that the DMP is connected to system ground before using the communication port.

ATTENTION: Assurez-vous que le DMP est branché au système de mise à la terre avant d'utiliser les ports de communication.

4-1 Introduction

This chapter describes the DMP system parameters that are set in the various categories of the Settings Menu. Default settings are the values set at the factory. For any given application, these settings may not provide adequate protection. It is the customer's responsibility to determine the appropriate settings for each of these parameters.

The default settings are stored in nonvolatile memory in the DMP and are always available. The default settings can be restored at any time from the Test/Maintenance Options menu, as described in *Chapter 3 – System Interfaces*.

CAUTION: Enabling the default settings will result in loss of all settings in effect before this action. This may result in inadequate motor protection.

ATTENTION: Si vous utilisez les réglages préajustés, vous perdrez tous les réglages établis auparavant. Une protection inadéquate du moteur peut en résulter.

Each of the parameters is described below, grouped by menu category. Each section contains a table listing the range of values for each parameter and the default setting.

All settings required by DMP systems with dc power supplies are set in software through the user interface. DMP systems with ac power supplies have a switch that can be set to either 120 or 240 Vac, as appropriate. See *Chapter 2 – Hardware Description and Specifications*

Appendices 1 and 2 contains blank settings forms DMP2 and DMP3, respectively, that may be copied

and used to record the settings for a particular application.

Figure 4-1 shows the sequence of key presses to access each of the menu items under each category of the Settings menu.

4-2 Communication Settings

This section contains descriptions of the parameters set with the Communication category of the Settings menu. Table 4-1 lists the ranges of available values and the default settings.

1. MOTOR NUMBER – This setting can be used for convenience to identify the motor and has no effect on DMP operation.
2. BAUD RATE – This setting establishes the baud rate (bits per second) of the DMP system's RS-485 serial port and must match the baud rate of the modem or serial device connected to the port. This setting can only be changed with the front-panel keypad. The DMP must be reinitialized by switching the power supply off and on for the new baud rate to be effective.
3. ADDRESS NO – This setting establishes the DMP's address on the RS-485 serial link. A maximum of 32 DMP systems are allowed on a serial link. Setting the value to 33 disables communications with the DMP. The host computer typically has address 0 on the serial link.
- 4-6. FUTURE ENH 1, 2, 3 – These settings are reserved for future enhancements to the DMP system communication capabilities. These should all be set to NOT USED.

Item	Parameter	Settings Range	Default
1	MOTOR NUMBER	0-320	0
2	BAUD RATE	110, 300, 1200, 2400, 4800, 9600	9600
3	ADDRESS NO	1-33	33
4	FUTURE ENH 1	USED, NOT USED	NOT USED
5	FUTURE ENH 2	USED, NOT USED	NOT USED
5	FUTURE ENH 3	USED, NOT USED	NOT USED

Table 4-1. Settings available in the Communication category.

Chapter 4 – Settings and Configurations

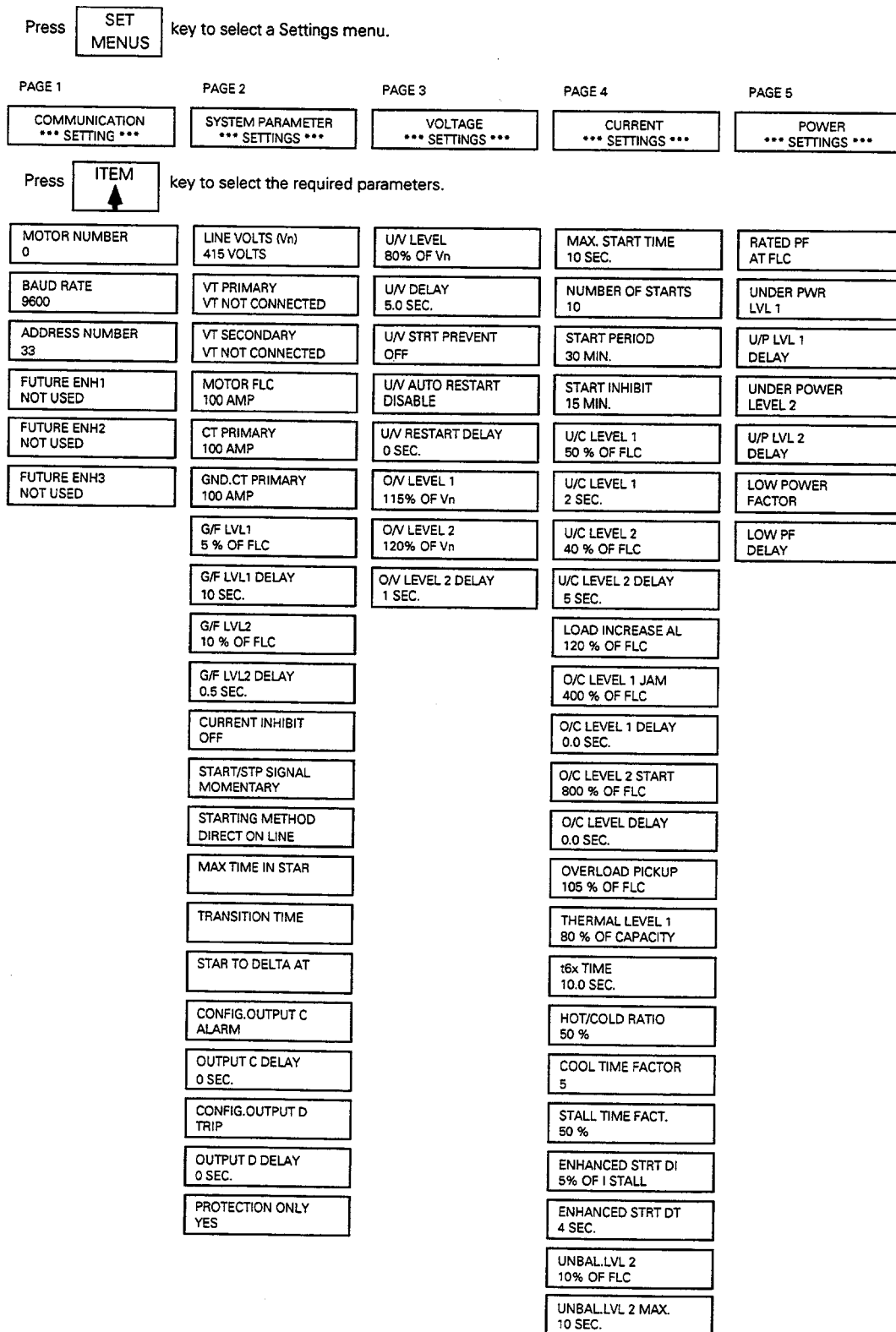

Figure 4-1. Sequence of menu items for each category of the Settings menu.

Press **SET MENUS** key to select a Settings menu.

PAGE 6

TEMPERATURE
*** SETTINGS ***

- RTD TYPE
PLATINUM 100 OHM
- RTD 1 LVL 1
120 C
- RTD 1 LVL 2
140 C
- RTD 2 LVL 1
120 C
- RTD 2 LVL 2
140 C
- RTD 3 LVL 1
120 C
- RTD 3 LVL 2
140 C
- RTD 4 LVL 1
120 C
- RTD 4 LVL 2
140 C
- RTD 5 LVL 1
120 C
- RTD 5 LVL 2
140 C
- RTD 6 LVL 1
120 C
- RTD 6 LVL 2
140 C
- RTD 7 LVL 1
120 C
- RTD 7 LVL 2
140 C
- RTD 8 LVL 1
120 C
- RTD 8 LVL 2
140 C
- RTD 9 LVL 1
120 C
- RTD 9 LVL 2
140 C
- RTD 10 LVL 1
120 C
- RTD 10 LVL 2
140 C

PAGE 7

TRIPPING / ALARM
*** OPTIONS ***

- MAX START TIME
TRIP: DISABLE
- TOO MANY STARTS
- U/C LEVEL 1
- U/C LEVEL 2
- LOAD INCREASED
- LEVEL 1 JAM
- LEVEL 2 SHUNT
- THERMAL LEVEL 1
- THERMAL LEVEL 2
- UNBALANCE LEVEL 1
- UNBALANCE LEVEL 2
- UNDERVOLTAGE
- O/V LEVEL 1
- O/V LEVEL 2
- PHASE LOSS
- PHASE SEQUENCE
- G/F LEVEL 1
- G/F LEVEL 2
- SER.PORT FAILURE
- INTERNAL FAILURE
- CONTROL CIR.OPEN
- WELDED CONTACTOR
- EXTERNAL FAULT 1
- EXTERNAL FAULT 2
- EXTERNAL FAULT 3
- UNDER PWR LVL 1
- UNDER PWR LVL 2
- LOW PWR FACTOR
PLC RESET ENABLED

- TEMP. 1 LEVEL 1
- TEMP. 1 LEVEL 2
- TEMP. 2 LEVEL 1
- TEMP. 2 LEVEL 2
- TEMP. 3 LEVEL 1
- TEMP. 3 LEVEL 2
- TEMP. 4 LEVEL 1
- TEMP. 4 LEVEL 2
- TEMP. 5 LEVEL 1
- TEMP. 5 LEVEL 2
- TEMP. 6 LEVEL 1
- TEMP. 6 LEVEL 2
- TEMP. 7 LEVEL 1
- TEMP. 7 LEVEL 2
- TEMP. 8 LEVEL 1
- TEMP. 8 LEVEL 2
- TEMP. 9 LEVEL 1
- TEMP. 9 LEVEL 2
- TEMP. 10 LEVEL 1
- TEMP. 10 LEVEL 2

Figure 4-1. Sequence of menu items for each category of the Settings menu (cont.).

Chapter 4 – Settings and Configurations

4-3 System Parameter Settings

This section contains descriptions of the parameters set with the System Parameter category of the Settings menu. Table 4-3 lists the ranges of available values and the default settings.

1. **LINE VOLTS (Vn)** – With a DMP2 Relay, set this parameter to the nominal line-to-line (primary) system voltage. This item is not required with a DMP3 Relay.
2. **LINE FREQUENCY** – Set to the nominal system frequency.
3. **VT PRIMARY** – For delta-, open delta-, or single line-to-line-connected VTs, set to the rated voltage of the primary windings. Table 4-2 contains the setting criteria for wye- or single line-to-ground-connected VTs. Set to NOT CONNECTED if VTs are not used.
4. **VT SECONDARY** – For delta or open delta connected VTs, set to the rated voltage of the secondary windings. Table 4-2 contains the setting criteria for single-phase or wye-connected VTs. Set to NOT CONNECTED if VTs are not used.
5. **MOTOR FLC** – This item should be set to the full-load current on the motor name plate.
6. **CT PRIMARY** – Set to the rated primary current of the CTs used in each phase. The CT secondary rating of 1 A or 5 A has no effect on this setting.
7. **GND CT PRIMARY** – Set to the rated primary current of the CT used for ground (earth) fault protection. If residual CT connections are used, this setting is the same as CT PRIMARY.
8. **GND FAULT LVL 1** – This level of ground-fault protection is primarily intended as an alarm and is usually set lower than GND FAULT LVL 2. The transient overreach due to dc offset is under 1% and can be disregarded in setting the pickup value. See the CURRENT INHIBIT setting described below for possible blocking of this function at very high fault currents.

9. **G/F LVL 1 DELAY** – Set to the time delay desired for ground-fault level 1.
10. **GND FAULT LVL 2** – This level of ground-fault protection is primarily intended as a trip and is usually set higher than GND FAULT LVL 1. The transient overreach due to dc offset is under 1% and can be disregarded in setting the pickup value. See the CURRENT INHIBIT setting described below for possible blocking of this function at very high fault currents. If this function is configured to trip, it will operate Output Relay B in addition to producing a TRIP output.
11. **G/F LVL 2 DELAY** – Set to the time delay desired for ground-fault level 2.
12. **CURRENT INHIBIT** – If a motor contactor is not rated adequately for the available short circuit current, this setting can be used to block the operation of output relays B and D to prevent damage to the contactor.

CAUTION: If this feature is used, well-coordinated backup protection must be provided at the upstream fuse or breaker to avoid damage to the contactor and motor.

ATTENTION: Si cette option est utilisée, une protection d'appoint bien coordonnée doit être fournie au fusible d'amont ou au disjoncteur afin d'éviter des dommages au contacteur et au moteur.

To minimize damage to the motor in the event that the backup protection fails, the DMP will allow operation of output relay D, in addition to relay A, on the thermal overload function. For proper coordination, the upstream backup protection must be faster than the DMP thermal overload function at all currents above the CURRENT INHIBIT setting. Except for special circumstances, this parameter should be set to OFF.

- 13.–16. These functions are not applicable with DMP2 and DMP3 Relays.

VT Connection	VT Primary	VT Secondary
Single VT, L-L connected	Rated voltage of primary windings	1.73 times rated voltage of secondary windings
Single VT, L-G connected	Rated voltage of primary windings (1)	Rated voltage of secondary windings (1)
3 VTs, Wye-connected	Rated voltage of primary windings (1)	Rated voltage of secondary windings (1)

1. For line-to-ground connected VTs (three-phase or single-phase), set both VT PRIMARY and VT SECONDARY to 1.73 times the respective winding rated voltage if the rated secondary voltage is less than 95 Vac.

Table 4-2. Criteria for setting VT PRIMARY and VT SECONDARY in single- and wye-connected VT applications.

Item	Parameter	Settings Range	Step Size	Default
1	LINE VOLTS (Un) (2)	100V-22kV	5 V up to 1 kV, 100 V above 1 kV	480 V
2	LINE FREQUENCY	50, 60 Hz	—	60 Hz
3	UT PRIMARY	100V-22kV; NOT CONNECTED	10 V up to 1 kV, 100 V above 1 kV	NOT CONNECTED
4	UT SECONDARY	95V-660V; NOT CONNECTED	5V	NOT CONNECTED
5	MOTOR FLC	1-2000 A	1 A up to 100 A, 5 A above 100 A	100 A
6	CT PRIMARY	1-2000 A	1 A up to 100 A, 5 A above 100 A	100 A
7	GND CT PRIMARY	1-2000 A	1 A up to 100 A, 5 A above 100 A	100 A
8	GND FAULT LVL 1	1-100% of MOTOR FLC	1%	5%
9	G/F LVL 1 DELAY	1-60 s	1 s	10 s
10	GND FAULT LVL 2	1-100% of MOTOR FLC	1%	10%
11	G/F LVL 2 DELAY	0.0-2.0 s	0.1 s	0.5 s
12	CURRENT INHIBIT	400-1000% of MOTOR FLC; OFF	10%	OFF
13	START/STP SIGNAL (1)			
14	STARTING METHOD (1)			
15A	MAX TIME IN STAR (1)			
15B	TRANSITION TIME (1)			
15C	STAR TO DELTA AT (1)			
16A	LOW SPEED FLC (1)			
16B	LOW SPD t6x TIME (1)			
17	CONFIG OUTPUT C	ALARM, CONTACTOR A, CONTACTOR B, START/RUN	—	ALARM
18	OUTPUT C DELAY	0-120 SEC	1 s	0 SEC
19	CONFIG OUTPUT D	TRIP, TRIP-FAIL SAFE, CONTACTOR A, CONTACTOR B	—	TRIP
20	OUTPUT D DELAY	0-120 SEC	1 s	0 SEC
21	PROTECTION ONLY (1)			

(1) Settings identified are not applicable with DMP2 and DMP3 Relays.

(2) Settings identified are applicable only with DMP2 Relays.

Table 4-3. Settings available in the System Parameter category.

Chapter 4 – Settings and Configurations

17. CONFIG OUTPUT C – Set to the desired configuration for output relay C:
 - ALARM: The output relay is picked up normally and drops out on any alarm condition, with an adjustable time delay, or on loss of DMP control power. See *Section 4-8 Tripping and Alarm Options* for configuring the alarm conditions.
 - CONTACTOR A: Configures output relay C to operate with output relay A (Overload Trip), but with an adjustable time delay. This configuration should not be used unless required by a specific application.
 - CONTACTOR B: Configures output relay C to operate with output relay B (Ground Fault Trip), but with an adjustable time delay. This configuration should not be used unless required by a specific application.
 - START/RUN: This setting is *not* applicable to DMP2 and DMP3 Relays and must not be used.
18. OUTPUT C DELAY – Set to the desired time delay for output relay C. The setting should be 0 second unless a specific application requires it otherwise.
19. CONFIG OUTPUT D – Set to the desired configuration for output relay D.
 - TRIP: The output relay is normally dropped out and picks up on any trip condition. See *Section 4-8 Tripping and Alarm Options* for configuring the trip conditions.
 - TRIP-FAIL SAFE: Similar to the TRIP option with the addition of fail-safe operation. The output relay is normally energized and drops out on any trip condition or on loss of control power to the DMP. See *Section 4-8 Tripping and Alarm Options* for configuring the trip conditions.
 - CONTACTOR A: Configures output relay D to operate with output relay A, but with an adjustable time delay.
 - CONTACTOR B: Configures output relay D to operate with output relay B, but with an adjustable time delay.
20. OUTPUT D DELAY – Set to the desired time delay for output relay D, if it is configured as CONTACTOR A or B. This setting adds no delay if output relay D is configured as TRIP or TRIP-FAIL SAFE. The setting should be 0 second unless a specific application requires it otherwise.
21. PROTECTION ONLY – This function is not applicable to DMP2 and DMP3 Relays. It should be set to YES, after which it can not be changed.

4-4 Voltage Settings

This section contains descriptions of the parameters set with the Voltage category of the Settings menu. Table 4-4 lists the ranges of available values and the default settings.

Items 1, 2, 6, 7, and 8 below are applicable only to the DMP2 Relay; the DMP3 ignores these settings.

1. U/V LEVEL – This function sets the threshold for undervoltage protection. It is active only when the motor is in START or RUN mode. The DMP computes an average of the three line-to-line voltages and compares it with the threshold set for this function.

Undervoltage protection can be used with either single- or three- phase VT inputs. VT connections are described in *Chapter 1 – Product Description*. If no voltage input is connected to the DMP, both the trip and alarm options of this function must be disabled. See *Section 4-8 Tripping and Alarm Options* for configuring these options.
2. U/V DELAY – This function sets a definite time delay to undervoltage protection operation. This delay can be used to prevent nuisance operations during normal dips in the motor supply voltage.
3. U/V START PREVENT – This function is not applicable to the DMP2 and DMP3 Relays and should be set to OFF.
4. U/V AUTO RESTART – This function is not applicable to the DMP2 and DMP3 Relays and should be set to DISABLE.

Item	Parameter	Settings Range	Step Size	Default
1	U/U LEVEL (2)	50–95% of Vn	1%	80%
2	U/U DELAY (2)	0.2–10 s	0.1 s	5.0 s
3	U/U SSTR PREVENT (1)			
4	U/U AUTO RESTART (1)			
5	U/U RSTRT DELAY (1)			
6	O/V LEVEL 1 (2)	100–120% of Vn	1%	115%
7	O/V LEVEL 2 (2)	100–120% of Vn	1%	120%
8	O/V LVL 2 DELAY (2)	1–100 SEC	1 s	1 s

(1) Settings identified are not applicable with DMP2 and DMP3 Relays.

(2) Settings identified are applicable only with DMP2 Relays.

Table 4–4. Settings available in the Voltage category.

5. U/V RESTRT DELAY – This function is not applicable to the DMP2 and DMP3 Relays and any setting is ignored.

6. O/V LEVEL 1 – This level of overvoltage protection is primarily intended as an alarm and is usually set lower than O/V LEVEL 2. The time delay is factory set to 1 second.

Overvoltage protection can be used with either single- or three- phase VT inputs. VT connections are described in *Chapter 1 – Product Description*. If no voltage input is connected to the DMP, both the trip and alarm options of this function must be disabled. See *Section 4–8 Tripping and Alarm Options* for configuring these options. This comment also applies to item 7.

7. O/V LEVEL 2 – This level of overvoltage protection is primarily intended as a trip, is usually set higher than O/V LEVEL 1, and has an adjustable time delay. The previous paragraph applies to this item also.

8. O/V LVL 2 DELAY – This setting provides a definite time delay for the O/V LEVEL 2 function. This delay can help prevent nuisance operations during normal momentary overvoltage conditions in the motor power supply.

The START, STOP, and RUN modes of the motor are determined as follows by the DMP2 and DMP3 Relays:

- From STOP mode, the DMP switches to START mode when the motor current is greater than (OVERLOAD PICKUP + 10%) of MOTOR FLC.
- From START mode, the DMP switches to RUN mode when the motor current drops below (OVERLOAD PICKUP + 10%) of MOTOR FLC. The DMP must be in START mode before it can go to RUN mode.
- From RUN mode, the DMP switches to STOP mode when the motor current drops below 12% of MOTOR FLC, or when a trip condition occurs. The field current of a synchronous motor should be adjusted so that it provides a motor current of at least 12%, to prevent the DMP from switching to STOP mode under a no-load condition.

1. MAX START TIME – If the actual start time exceeds this setting, the DMP will drop out of START mode. This setting should be above the highest start time expected for the application. The actual start time (LAST START PERIOD) measured by the DMP is saved as part of the Statistical Data and can be used to verify the expected start time.

2. NUMBER OF STARTS – If the total number of starts within the STARTS PERIOD time window exceeds this setting, protection function TOO MANY STARTS operates.

4–5 Current Settings

This section contains descriptions of the parameters set with the Current category of the Settings menu. Table 4–5 lists the ranges of available values and the default settings.

Chapter 4 – Settings and Configurations

Item	Parameter	Settings Range	Step Size	Default
1	MAX START TIME	1-250 s	1 s	10 s
2	NUMBER OF STARTS	1-10	1	10
3	STARTS PERIOD	1-60 min	1 min	30 min
4	START INHIBIT (1)			
5	U/C LEVEL 1	10-90% of MOTOR FLC	1%	50%
6	U/C LVL 1 DELAY	1-60 s	1 s	2 s
7	U/C LEVEL 2	10-90% of MOTOR FLC	1%	40%
8	U/C LVL 2 DELAY	1-60 s	1 s	5 s
9	LOAD INCREASE	60-150% of MOTOR FLC	1%	120%
10	O/C LEVEL 1-JAM	100-500% of MOTOR FLC	10%	400%
11	O/C LVL 1 DELAY	0.5-10 s	0.5 s	2.0 s
12	O/C LVL 2-SHORT	400-1200% of MOTOR FLC	10%	800%
13	O/C LVL 2 DELAY	0-4 s	0.1 s	0.5 s
14	OVERLOAD PICKUP	60-130% of MOTOR FLC	1%	105%
15	THERMAL LEVEL 1	50-99% of THERMAL CAPACITY	1%	805
16	t _{6x} TIME	0.5-120 s	0.5 s	2.0 s
17	HOT/COLD RATIO	20-100% of THERMAL CAPACITY	1%	50%
18	COOL TIME FACTOR	1-15	1	5
19	STALL TIME FCTR	20-100%	1%	50%
20	ENHANCED STRT:dI	5-20% of stall current, OFF	1%	10%
21	ENHANCED STRT:dT	4-40 s	0.5 s	10 s
22	UNBALANCE LVL 2	10-40% of MOTOR FLC	1%	15%
23	U/B LVL2 MAX T	20-120 s	1 s	30 s

(1) This setting is not applicable with DMP2 and DMP3 Relays.

Table 4-5. Settings available in the Current category.

3. **STARTS PERIOD** – This setting determines the time window during which the DMP counts the total number of starts. This is a dynamic window, always looking back from the present time.
4. **START INHIBIT** – This function is not applicable to DMP2 and DMP3 Relays and any setting is ignored.
5. **U/C LEVEL 1** – Undercurrent protection is only active when the motor is in RUN mode. This level is primarily intended for an alarm and is usually set higher than U/C LEVEL 2. Sustained undercurrent may be an indication of total or partial loss of load and may justify trip or alarm conditions in some applications.
6. **U/C LVL 1 DELAY** – This setting defines the time delay before U/C LEVEL 1 operates.
7. **U/C LEVEL 2** – This level is primarily intended for a trip and is usually set lower than U/C LEVEL 1, but is otherwise identical.
8. **U/C LVL 2 DELAY** – This setting defines the time delay before U/C LEVEL 2 operates.
9. **LOAD INCREASE** – This function is only active when the motor is in RUN mode. It provides an operation when the average motor current exceeds the setting for more than 5 seconds.
10. **O/C LEVEL 1-JAM** – This function detects a jam or stall condition in a running motor. A trip or alarm is generated if the average motor current is above the setting for longer than the O/C LVL 1 DELAY.
11. **O/C LVL 1 DELAY** – Sets a definite time delay before jam or stall overcurrent protection operates.

12. O/C LVL 2-SHORT – This function detects a short-circuit in the motor. A trip or alarm is generated if any of the phase currents is above the setting for longer than the O/C LVL 2 DELAY. The transient overreach of this function due to a dc offset is under 1% and may be disregarded in setting the pickup value.

The pickup should be set at least 5% above the highest expected start current. The actual start current (LAST START MAX I) measure by the DMP is saved as part of the Statistical Data and can be used to verify the expected starting current. See the setting information for CURRENT INHIBIT in *4-3 System Parameter Settings* for possible blocking of this function at very high fault currents.

13. O/C LVL 2 DELAY – Sets a definite time delay before short-circuit overcurrent protection operates. This delay is in addition to the normal operating time for this function of 40–80 ms.

Items 14–21 are interacting settings related to thermal overload protection. Based on these settings, the DMP dynamically computes the thermal condition (referred to as THERMAL CAPACITY) of the motor. The computed THERMAL CAPACITY is proportional to motor temperature. A THERMAL CAPACITY value of 100% is equivalent to the maximum allowable temperature of the motor, at which point the function THERMAL LEVEL 2 operates. If THERMAL LEVEL 2 is configured to trip, it will also operate output relay A.

14. OVERLOAD PICKUP – Sets the pickup threshold for thermal overload functions. This setting should be kept at the default of 105% for motors with service factors of 1.1 to 1.15. The pickup should be at least 5% below the service factor of the motor.

15. THERMAL LEVEL 1 – This function is intended to generate an alarm when the THERMAL CAPACITY exceeds the setting.

16. t6x TIME – This setting, in conjunction with OVERLOAD PICKUP, establishes the overload characteristic curve for THERMAL LEVEL 2 pro-

tection. Figures 4–2 and 4–3 contain the families of curves for cold and hot motor conditions.

A “cold” motor is defined as at ambient temperature and has a THERMAL CAPACITY of 0%. A “hot” motor has been running at just under the overload pickup current long enough to attain a steady-state temperature. The steady-state THERMAL CAPACITY at different current levels can be determined with the following equations,

$$TC = \begin{cases} \frac{100 - HCR}{(I/OLPU)^2}, & I < OLPU \\ 100 (I/OLPU)^2, & I \geq OLPU \end{cases}$$

where TC is the steady-state THERMAL CAPACITY in %, HCR is the HOT/COLD RATIO setting, I is the steady-state current in % of MOTOR FLC, and OLPU is the OVERLOAD PICKUP setting.

The overload curves in Figures 4–2 and 4–3 are based on an OVERLOAD PICKUP setting of 105% and a HOT/COLD RATIO of 50%. As shown in Figures 4–2 and 4–3, the t6x TIME setting is the operating time of THERMAL LEVEL 2 at a current equal to six times the MOTOR FLC when it is in cold condition.

17. HOT/COLD RATIO – This setting is the available thermal capacity of the motor in percentage of cold motor capability.

18. COOL TIME FACTOR – This setting is the ratio of the cooling time constant of the stopped motor to the heating/cooling time constant of the running motor. It is used to model motor cooling after a STOP condition.

19. STALL TIME FACTOR – This setting is the ratio of the heating time constant of a motor when its rotor is stopped to the heating time constant when it is rotating. This setting determines the modification of the overload curve used by the DMP during a part of the motor starting mode. The t6x TIME is reduced to (t6x TIME) X (STALL TIME FCTR)/100 until there is evidence of motor rotation.

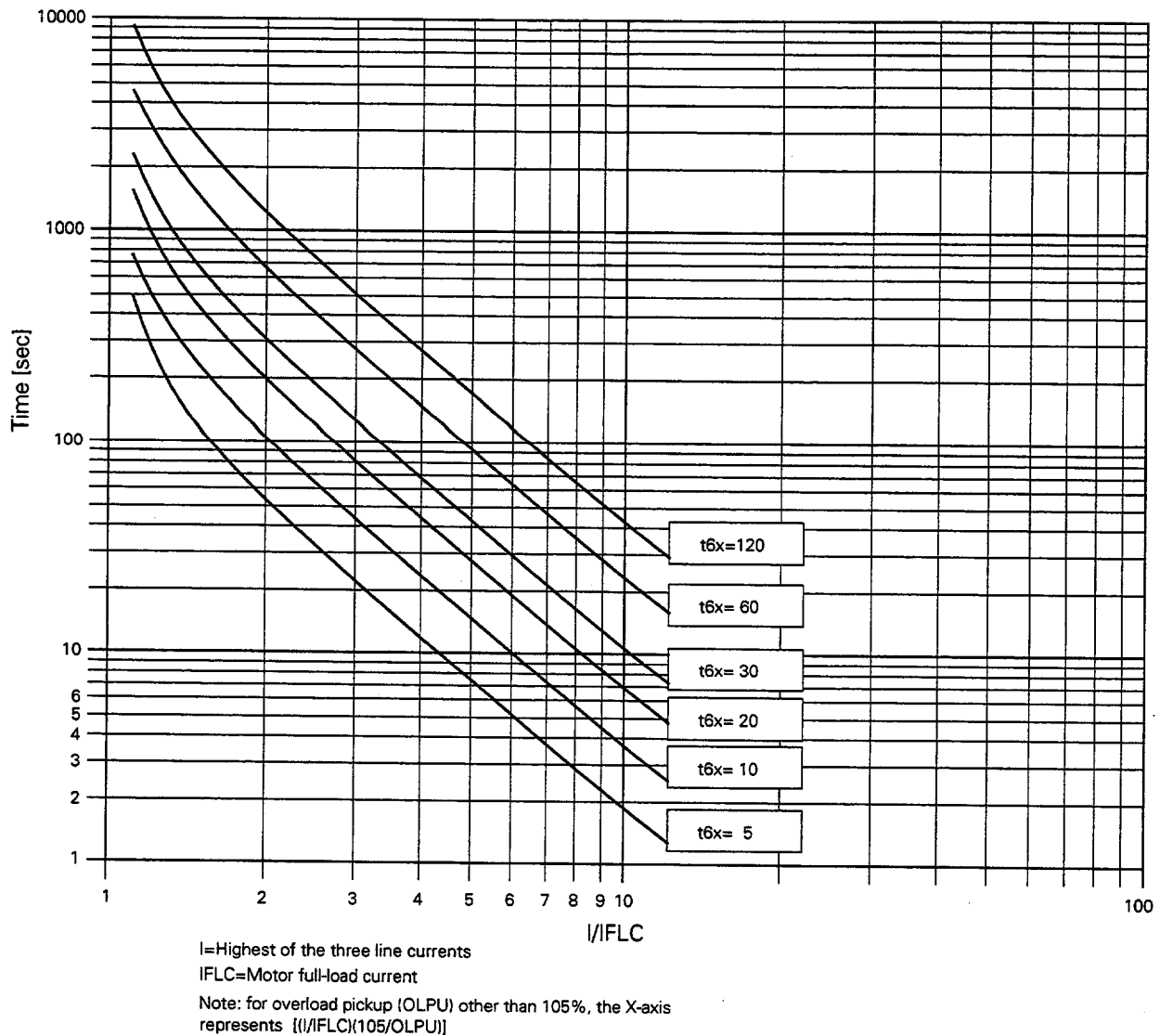

Figure 4-2. Thermal overload protection characteristic curves for a cold motor and overload pickup of 105%.

Either a speed switch input or the enhanced start logic (described next) can be used to detect the rotation of the motor.

This feature can be particularly useful for motors having acceleration times that are significantly longer than their safe stall time at locked rotor, since it allows successful motor starting with realistic overload protection and without compromising the safe stall time.

20. ENHANCED STRT: dI – Described with function 21.

21. ENHANCED STRT: dT – The enhanced start function logic (patent pending) implemented in the DMP provides startup protection to a motor with no speed switch. Following a successful START command, the DMP computes a drop in current (dI) during a time window (dT). The time window is started 30 cycles after motor start current is detected to override the effect of any dc offset. The current at the start of this time window is considered to be the stall current. ENHANCED STRT: dI is a percentage drop in the stall current and ENHANCED STRT: dT defines the length of the time window.

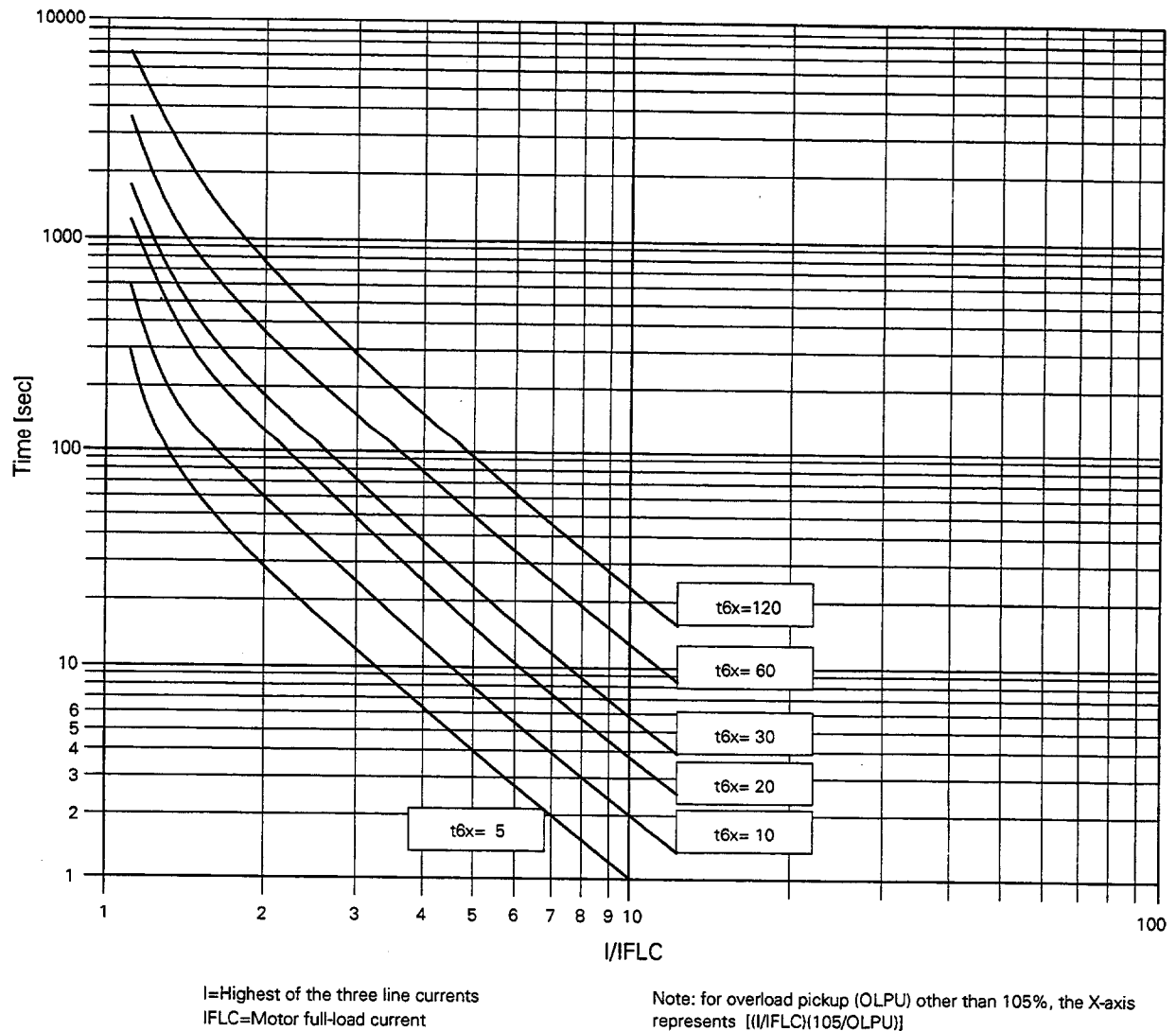

Figure 4-3. Thermal overload protection characteristic curves for a hot motor and overload pickup of 105%.

The DMP interprets a drop in the current greater than ENHANCED STRT: dI during the time window as indication of motor rotation and switches the time factor to the higher t6x TIME, as described under STALL TIME FACTOR.

If the motor voltage signal is connected to the DMP, the Enhanced Starting logic accounts for any drop in the voltage accompanied by a drop in current. This increases security in case the system voltage drops due to other, unrelated activities during motor starting.

Set ENHANCED STRT: dI to 5% unless special circumstances dictate otherwise. ENHANCED STRT: dT should be set as high as the locked

rotor capability of the motor allows. It must provide a safe margin below the operating time of the Thermal Level 2 curve, based on the stall current and the overload curve lowered by the STALL TIME FACTOR.

If dI is set to OFF, the motor rotation is determined based on the speed switch input. If it is set to a particular value, the rotation is determined by the logic and the speed switch input is ignored.

22. UNBALANCE LVL 2 – The DMP provides two levels of current unbalance protection. UNBALANCE LVL 2 sets the operating time as inversely proportional to the square of the percentage

Chapter 4 – Settings and Configurations

unbalance, with a minimum delay of 1 second. Figure 4-3 contains the characteristic curves for this function. The percentage unbalance is computed with the formula

$$\% \text{ UNBALANCE} = 100 \cdot (I_{\max} - I_{\min}) / I_r$$

where I_{\max} is the largest of the three line currents, I_{\min} is the smallest of the three line currents, and I_r is the larger of I_{\max} and MOTOR FLC.

This setting defines the threshold below which current unbalance protection is blocked. UNBALANCE LVL 1 is automatically set at 50% of UNBALANCE LVL 2, with a factory-set time delay of 1 second. The level 1 function is intended as an alarm, while level 2 serves as a trip.

- 23. U/B LVL 2 MAX T – This setting selects the characteristic curve from Figure 4-4 and represents the function’s operating time at an unbalance of 10%.

4-6 Power Settings

This section contains descriptions of the parameters set with the Power category of the Settings menu. Table 4-6 lists the ranges of available values and the default settings.

All of the following power functions are applicable with the DMP2 Relay only. The DMP3 ignores these settings.

- 1. RATED PF AT FLC – Set this to the rated power factor (PF) of the motor at full-load current, as supplied by the motor manufacturer. The DMP calculates the rated power of the motor using the following formula to process the underpower functions:

$$\text{Rated Power} = 1.732 \times (\text{Line Voltage, } V_n) \times (\text{Motor FLC}) \times (\text{Rated PF}).$$

- 2. UNDER PWR LVL 1 – The DMP provides two levels of underpower protection, with individually adjustable definite time delays. Underpower protection is operational only when the motor is in RUN mode. Level 1 is primarily intended as an alarm and is usually set higher than Level 2. Sustained underpower may be an indication of total or partial loss of motor load and may justify an alarm or trip. A three-phase voltage input is required for proper operation of these functions.

Trip and alarm options for this function must be disabled if three-phase voltage is not connected to the DMP. See *Section 4-8 Tripping and Alarm Options* to configure these options.

- 3. U/P LVL 1 DELAY – Sets the time delay for the UNDER PWR LVL 1 function.

Item	Parameter	Settings Range	Step Size	Default
1	RATED PF AT FLC	0.50-0.99	0.01	0.88
2	UNDER PWR LVL 1	5-99% of calculated rated power	1%	45%
3	U/ LVL 1 DELAY	1-120 s	1 s	30 s
4	UNDER PWR LVL 2	5-99% of calculated rated power	1%	25%
5	U/P LVL 2 DELAY	1-120 s	1 s	30 s
6	LOW POWER FACTOR	0.20-0.98 (LAG)	0.01	0.80
7	LOW PF DELAY	1-120 s	1 s	30 s

Table 4-6. Settings available in the Power category. These functions are only applicable with the DMP2 Relay.

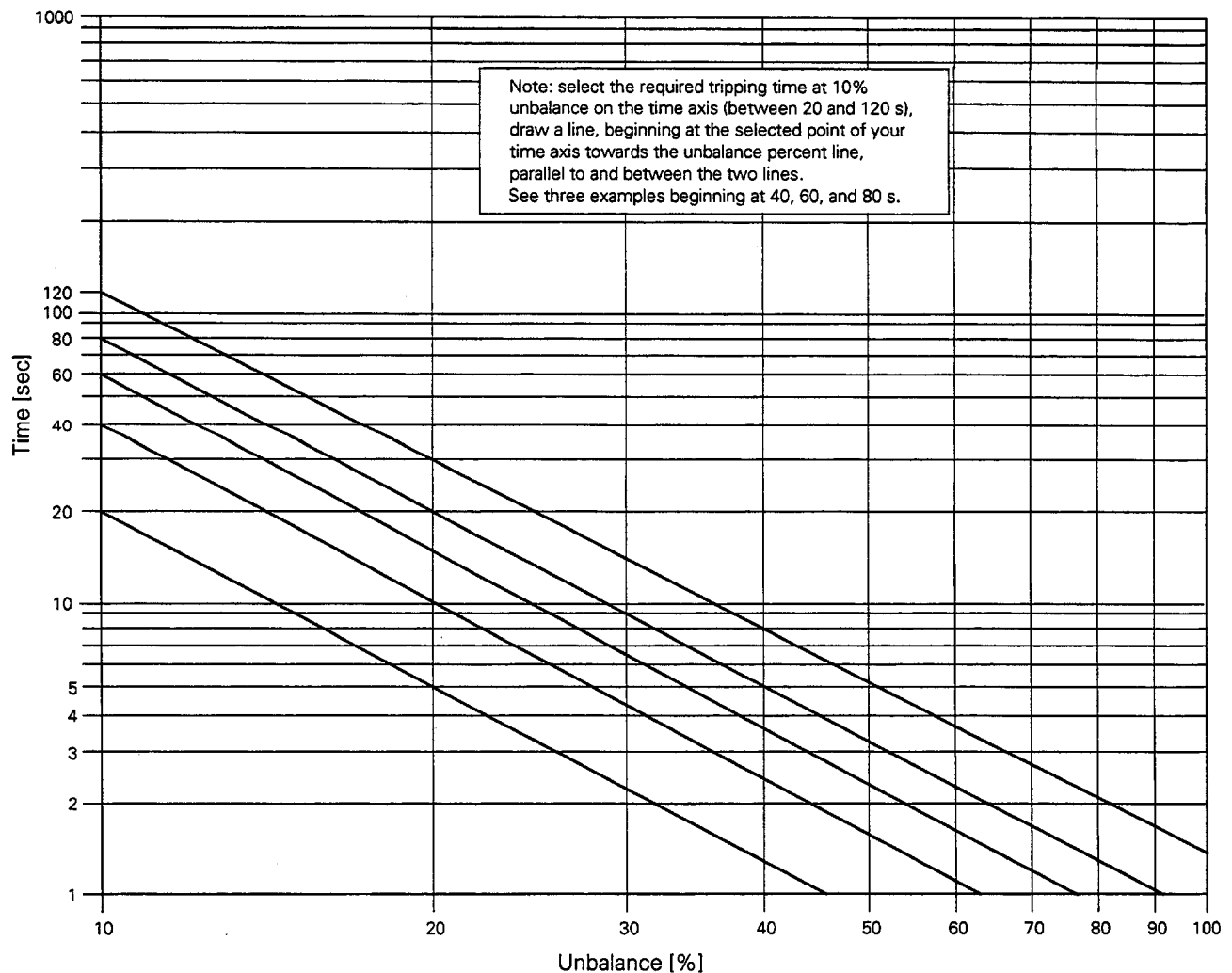

Figure 4-4. Characteristic curves for current unbalance protection.

- 4. UNDER PWR LVL 2 – This function is identical to UNDER PWR LVL 1, except that it is primarily intended as a trip and is usually set lower.
- 5. U/P LVL 2 DELAY – Sets the time delay for the UNDER PWR LVL 2 function.
- 6. LOW POWER FACTOR – Low power factor protection operates when the lagging power factor drops below the set value for a time longer than the LOW PF DELAY. It is operational only when the motor is in RUN mode. This function can be used to detect a loss of power factor correction in an induction motor or a loss of field in a synchronous motor.

options for this function must be disabled if three-phase voltage is not connected to the DMP. See Section 4-8 *Tripping and Alarm Options* to configure these options.

- 7. LOW PF DELAY – Sets the definite time delay for low power factor protection.

A three-phase voltage input is required for operation of this function. Trip and alarm

Chapter 4 – Settings and Configurations

4-7 Temperature Settings

This section contains descriptions of the parameters set with the Temperature category of the Settings menu. Table 4-7 lists the ranges of available values and the default settings.

1. RTD TYPE – Two distinct families of DMP models cover the three types of resistance-temperature detectors (RTDs). Before setting this item, verify that the DMP model in use matches the type of available RTDs and also that the resistance values of the RTDs matches those given in Table 1-1.

2-21. RTD X LVL 1, RTD X LVL 2 – The DMP back panel has ten inputs for RTDs. Each RTD has two levels of settings available. Level 1 is normally intended as an alarm and is set lower than Level 2, which is intended as a trip. In addition, the DMP will alarm and block tripping by an open RTD. These settings should be based on motor insulation temperature class and/or bearing temperature limits, with adequate margins.

Item	Parameter	Settings Range	Step Size	Default
1	RTD TYPE	COPPER 10 OHM, PLATINUM 100 OHM, NICKEL 120 OHM	—	PLATINUM 100 OHM
2	RTD 1 LVL 1	0-200 C	1° C	120 C
3	RTD 1 LVL 2	0-200 C	1° C	140 C
4	RTD 2 LVL 1	0-200 C	1° C	120 C
5	RTD 2 LVL 2	0-200 C	1° C	140 C
6	RTD 3 LVL 1	0-200 C	1° C	120 C
7	RTD 3 LVL 2	0-200 C	1° C	140 C
8	RTD 4 LVL 1	0-200 C	1° C	120 C
9	RTD 4 LVL 2	0-200 C	1° C	140 C
10	RTD 5 LVL 1	0-200 C	1° C	120 C
11	RTD 5 LVL 2	0-200 C	1° C	140 C
12	RTD 6 LVL 1	0-200 C	1° C	120 C
13	RTD 6 LVL 2	0-200 C	1° C	140 C
14	RTD 7 LVL 1	0-200 C	1° C	80 C
15	RTD 7 LVL 2	0-200 C	1° C	100 C
16	RTD 8 LVL 1	0-200 C	1° C	80 C
17	RTD 8 LVL 2	0-200 C	1° C	100 C
18	RTD 9 LVL 1	0-200 C	1° C	80 C
19	RTD 9 LVL 2	0-200 C	1° C	100 C
20	RTD 10 LVL 1	0-200 C	1° C	80 C
21	RTD 10 LVL 2	0-200 C	1° C	100 C

Table 4-7. Settings available in the Temperature category.

4-8 Tripping and Alarm Options

The protection functions described in this chapter and in *Chapter 1 – Product Description* are consolidated into 48 items and listed in Table 4-9. Each function has five options that can be individually enabled or disabled, as follows:

- **TRIP** – When this option is enabled, the DMP performs the following operations when the function operates:
 - Turns on the TRIP LED.
 - Energizes output relay D if it is configured as TRIP.
 - De-energizes output relay D if it is configured as TRIP-FAIL SAFE.
 - Energizes output relay A on a Thermal Level 2 trip.
 - Energizes output relay B on a Ground Fault Level 2 trip.
- **ALARM** – When this option is enabled, The DMP performs the following operations when the function operates:
 - Turns on the ALARM LED.
 - De-energizes output relay C if it is configured as ALARM.
- **AUTO RST** – If this option is enabled, the DMP automatically resets when the condition causing the function to operate has reverted to normal. This option also resets any TRIP or ALARM message on the LCD. The fault data in the DMP memory is retained. This option

should be kept disabled unless particular conditions warrant its use.

- **PANEL RST** – If this option is enabled and the DMP is in Local Control mode, the DMP can be reset from the front panel following operation of the function, without authorized key switch input. This option should be disabled for all critical protection functions that must be reported or recorded before reset. A person with authorized key may always reset the DMP regardless of this setting.
- **PLC RESET** – If this option is enabled and the DMP is in PLC (programmable logic controller) mode, the DMP can be reset from the PLC RESET input contact following operation of the function. If a PLC is not used, this function should be disabled.

The following points must be considered when setting TRIP and ALARM options:

1. If the voltage signal input is single-phase or if no voltage signal input is connected to the DMP, both TRIP and ALARM functions must be disabled, as shown in Table 4-8.
2. If any of the three External Faults 1, 2, or 3 is not used, both TRIP and ALARM options of that function must be DISABLED.
3. The functions CONTROL CIRCUIT OPEN and WELDED CONTACTOR are not applicable with the DMP2 and DMP3 Relays. Disable both TRIP and ALARM options of these functions.

Function	Voltage Signal Input Connected		
	Three-Phase Input	Single-Phase Input	No Voltage Input
UNDERVOLTAGE	No limitations	No limitations	DISABLE
O/V LVL 1 and 2	No limitations	No limitations	DISABLE
PHASE LOSS	No limitations	DISABLE	DISABLE
PHASE SEQUENCE	No limitations	DISABLE	DISABLE
UNDER PWR 1 and 2	No limitations	DISABLE	DISABLE
LOW POWER FACTOR	No limitations	DISABLE	DISABLE

Table 4-8. TRIP and ALARM setting limitations on voltage-dependent functions.

Chapter 4 – Settings and Configurations

Item #	Function	Trip	Alarm	Auto Rst	Panel Rst	PLC Rst	When Active	
1	MAX START TIME	DSABL	ENABL	DSABL	ENABL	ENABL	START	
2	TOO MANY STARTS	DSABL	DSABL	DSABL	ENABL	ENABL	START	
3	U/C LEVEL 1	DSABL	ENABL	DSABL	ENABL	ENABL	RUN	
4	U/C LEVEL 2	DSABL	DSABL	DSABL	ENABL	ENABL	RUN	
5	LOAD INCREASED	DSABL	ENABL	DSABL	ENABL	ENABL	RUN	
6	O/C LEVEL 1-JAM	ENABL	ENABL	DSABL	ENABL	ENABL	RUN	
7	O/C LUL2-SHORT	ENABL	ENABL	DSABL	ENABL	ENABL	Always	
8	THERMAL LEVEL 1	DSABL	ENABL	DSABL	ENABL	ENABL	Always	
9	THERMAL LEVEL 2	ENABL	ENABL	DSABL	ENABL	ENABL	Always	
10	UNBALANCE LUL 1	DSABL	ENABL	DSABL	ENABL	ENABL	Always	
11	UNBALANCE LUL 2	ENABL	ENABL	DSABL	ENABL	ENABL	Always	
12	UNDERVOLTAGE (2)	DSABL	ENABL	DSABL	ENABL	ENABL	RUN & START	
13	O/U LEVEL 1 (2)	DSABL	ENABL	DSABL	ENABL	ENABL	RUN & START	
14	O/U LEVEL 2 (2)	ENABL	ENABL	DSABL	ENABL	ENABL	RUN & START	
15	PHASE LOSS (2)	ENABL	ENABL	DSABL	ENABL	ENABL	Always	
16	PHASE SEQUENCE (2)	ENABL	ENABL	DSABL	ENABL	ENABL	Always	
17	GND FLT LUL 1	DSABL	ENABL	DSABL	ENABL	ENABL	Always	
18	GND FLT LUL 2	ENABL	ENABL	DSABL	DSABL	DSABL	Always	
19	COMM PORT FAILED	DSABL	DSABL	DSABL	ENABL	ENABL	Always	
20	INTERNAL FAILURE	DSABL	ENABL	DSABL	DSABL	DSABL	Always	
21	CONTROL CIR OPEN (1)							
22	WELDED CONTACTOR (1)							
23	EXTERNAL FAULT 1	DSABL	DSABL	DSABL	ENABL	ENABL	Always	
24	EXTERNAL FAULT 2	DSABL	DSABL	DSABL	ENABL	ENABL	Always	
25	EXTERNAL FAULT 3	DSABL	DSABL	DSABL	ENABL	ENABL	Always	
26	RTD 1 - LEVEL 1	DSABL	DSABL	DSABL	ENABL	ENABL	Always	
27	RTD 1 - LEVEL 2	DSABL	DSABL	DSABL	ENABL	ENABL	Always	
28	RTD 2 - LEVEL 1	DSABL	DSABL	DSABL	ENABL	ENABL	Always	
29	RTD 2 - LEVEL 2	DSABL	DSABL	DSABL	ENABL	ENABL	Always	
30	RTD 3 - LEVEL 1	DSABL	DSABL	DSABL	ENABL	ENABL	Always	
31	RTD 3 - LEVEL 2	DSABL	DSABL	DSABL	ENABL	ENABL	Always	
32	RTD 4 - LEVEL 1	DSABL	DSABL	DSABL	ENABL	ENABL	Always	
33	RTD 4 - LEVEL 2	DSABL	DSABL	DSABL	ENABL	ENABL	Always	
34	RTD 5 - LEVEL 1	DSABL	DSABL	DSABL	ENABL	ENABL	Always	
35	RTD 5 - LEVEL 2	DSABL	DSABL	DSABL	ENABL	ENABL	Always	
36	RTD 6 - LEVEL 1	DSABL	DSABL	DSABL	ENABL	ENABL	Always	
37	RTD 6 - LEVEL 2	DSABL	DSABL	DSABL	ENABL	ENABL	Always	
38	RTD 7 - LEVEL 1	DSABL	DSABL	DSABL	ENABL	ENABL	Always	
39	RTD 7 - LEVEL 2	DSABL	DSABL	DSABL	ENABL	ENABL	Always	
40	RTD 8 - LEVEL 1	DSABL	DSABL	DSABL	ENABL	ENABL	Always	
41	RTD 8 - LEVEL 2	DSABL	DSABL	DSABL	ENABL	ENABL	Always	
42	RTD 9 - LEVEL 1	DSABL	DSABL	DSABL	ENABL	ENABL	Always	
43	RTD 9 - LEVEL 2	DSABL	DSABL	DSABL	ENABL	ENABL	Always	
44	RTD 10 - LEVEL 1	DSABL	DSABL	DSABL	ENABL	ENABL	Always	
45	RTD 10 - LEVEL 2	DSABL	DSABL	DSABL	ENABL	ENABL	Always	
46	UNDER PWR LUL 1 (2)	DSABL	DSABL	DSABL	ENABL	ENABL	RUN	
47	UNDER PWR LUL 2 (2)	DSABL	DSABL	DSABL	ENABL	ENABL	RUN	
48	LOW POWER FACTOR (2)	DSABL	DSABL	DSABL	ENABL	ENABL	RUN	

(1) These settings are not applicable with the DMP2 or DMP3 Relay.

(2) These settings are applicable only with the DMP2 Relay.

Table 4-9. DMP protection functions and default settings for each tripping and alarming option.

DMP2 Protection System Settings

Location _____ Motor Identification _____
 Model Number DMP2 Program Version DMP

Item #	Description		Setting
-	Power Supply Switch (applicable to models with ac power supply only)		
Set Menu Category: Communication Settings			
1	MOTOR NUMBER	Identification Number	
2	BAUD RATE	Communications baud rate	
3	ADDRESS NO.	Serial link address number	
4	FUTURE ENH. 1	(for future use)	NOT USED
5	FUTURE ENH. 2	(for future use)	NOT USED
6	FUTURE ENH. 3	(for future use)	NOT USED
Set Menu Category: System Parameter Settings			
1	LINE VOLTS (Vn)	Rated primary voltage, line to line	
2	LINE FREQUENCY	Nominal system frequency	
3	VT PRIMARY	Rated voltage - VT primary winding	
4	VT SECONDARY	Rated voltage - VT secondary winding	
5	MOTOR FLC	Motor full-load current (FLC) - primary amperes	
6	CT PRIMARY	Rated primary current - phase CTs	
7	GND CT PRIMARY	Rated primary current - ground CT	
8	GND FAULT LVL 1	Ground overcurrent pickup level 1 - % of FLC	
9	G/F LVL 1 DELAY	Ground overcurrent level 1 delay - seconds	
10	GND FAULT LVL 2	Ground overcurrent pickup level 2 - % of FLC	
11	G/F LVL 2 DELAY	Ground overcurrent level 2 delay - seconds	
12	CURRENT INHIBIT	Inhibit current - % of FLC	
13	START/STP SIGNAL		
14	STARTING METHOD		
15A	MAX TIME IN START		
15B	TRANSITION TIME		
15C	STAR TO DELTA AT		
16A	LOW SPEED FLC		
16B	LOW SPD t6x TIME		
17	CONFIG OUTPUT C	Configuration of output relay C	
18	OUPUT C DELAY	Time delay of output relay C - seconds	
19	CONFIG OUTPUT D	Configuration of output relay D	
20	OUPUT D DELAY	Time delay of ouput relay D - seconds	
21	PROTECTION ONLY		YES
Set Menu Category: Voltage Settings			
1	U/V LEVEL	Undervoltage threshold level - % of Vn	
2	U/V DELAY	Time delay of undervoltage function - seconds	
3	U/V STRT PREVENT		OFF
4	U/V AUTO RESTART		DISABLE
5	U/V RSTRT DELAY		
6	O/V LEVEL 1	Overvoltage threshold level 1 - % of Vn	
7	O/V LEVEL 2	Overvoltage threshold level 2 - % of Vn	
8	O/V LVL 2 DELAY	Time delay of O/V LEVEL 2 function - seconds	

DMP2 Protection System Settings

GEK-105499

Location _____ Motor Identification _____
 Model Number **DMP2** Program Version **DMP**

Item #	Description	Setting
Set Menu Category: Current Settings		
1	MAX START TIME	Maximum motor starting time allowed – seconds
2	NUMBER OF STARTS	Maximum number of starts allowed within STARTS PERIOD
3	STARTS PERIOD	Time period for NUMBER OF STARTS – minutes
4	START INHIBIT	
5	U/C LEVEL 1	Undercurrent threshold level 1 – % of FLC
6	U/C LEVEL 1 DELAY	Time delay for U/C LEVEL 1 function – seconds
7	U/C LEVEL 2	Undercurrent threshold level 2 – % of FLC
8	U/C LEVEL 2 DELAY	Time delay for U/C LEVEL 2 function – seconds
9	LOAD INCREASE	Threshold level of Load Increase function – % of FLC
10	O/C LEVEL 1 - JAM	Overcurrent threshold level 1 – % of FLC
11	O/C LVL 1 DELAY	Time delay of O/C LEVEL 1 function – seconds
12	O/C LEVEL 2 - SHORT	Overcurrent threshold level 2 – % of FLC
13	O/C LVL 2 DELAY	Time delay of O/C LEVEL 2 function – seconds
14	OVERLOAD PICKUP	Pickup level of thermal overload function – % of FLC
15	THERMAL LEVEL 1	Operate level 1 of thermal overload function – % of Thermal Capacity
16	t6x TIME	t6x time factor of thermal overload function – seconds
17	HOT/COLD RATIO	Thermal capability of Hot motor in % of capability of Cold motor
18	COOL TIME FACTOR	Ratio of cooling time constant of stopped motor to running motor
19	STALL TIME FCTR	Heating time constant of stopped motor as % of running motor
20	ENHANCED STRT:dI	Decrement in current during motor start – % of stall current
21	ENHANCED STRT:dT	Time window for ENHANCED STRT:dI setting – seconds
22	UNBALANCE LVL 2	Unbalance current threshold level 2 – %
23	U/B LVL 2 MAX T	Operate time at unbalance current of 10% – seconds
Set Menu Category: Power Settings		
1	RATED PF AT FLC	Rated power factor at motor full-load current
2	UNDER PWR LVL 1	Underpower threshold level 1 – % of rated power
3	U/P LVL 1 DELAY	Time delay of UNDER PWR LVL 1 function – seconds
4	UNDER PWR LVL 2	Underpower threshold level 2 – % of rated power
5	U/P LVL 2 DELAY	Time delay of UNDER PWR LVL 2 function – seconds
6	LOW POWER FACTOR	Low power factor threshold
7	LOW PF DELAY	Time delay of LOW POWER FACTOR function – seconds
Set Menu Category: Temperature Settings		
1	RTD TYPE	Type of RTDs used
2	RTD 1 LVL 1	Temperature threshold level 1 of RTD 1 – °C
3	RTD 1 LVL 2	Temperature threshold level 2 of RTD 1 – °C
4	RTD 2 LVL 1	Temperature threshold level 1 of RTD 2 – °C
5	RTD 2 LVL 2	Temperature threshold level 2 of RTD 2 – °C
6	RTD 3 LVL 1	Temperature threshold level 1 of RTD 3 – °C
7	RTD 3 LVL 2	Temperature threshold level 2 of RTD 3 – °C
8	RTD 4 LVL 1	Temperature threshold level 1 of RTD 4 – °C
9	RTD 4 LVL 2	Temperature threshold level 2 of RTD 4 – °C

DMP2 Protection System Settings

Location _____ **Motor Identification** _____
Model Number DMP2 **Program Version** DMP

Item #	Description						Setting
Set Menu Category: Temperature Settings (cont.)							
10	RTD 5 LVL 1	Temperature threshold level 1 of RTD 5 - °C					
11	RTD 5 LVL 2	Temperature threshold level 2 of RTD 5 - °C					
12	RTD 6 LVL 1	Temperature threshold level 1 of RTD 6 - °C					
13	RTD 6 LVL 2	Temperature threshold level 2 of RTD 6 - °C					
14	RTD 7 LVL 1	Temperature threshold level 1 of RTD 7 - °C					
15	RTD 7 LVL 2	Temperature threshold level 2 of RTD 7 - °C					
16	RTD 8 LVL 1	Temperature threshold level 1 of RTD 8 - °C					
17	RTD 8 LVL 2	Temperature threshold level 2 of RTD 8 - °C					
18	RTD 9 LVL 1	Temperature threshold level 1 of RTD 9 - °C					
19	RTD 9 LVL 2	Temperature threshold level 2 of RTD 9 - °C					
20	RTD 10 LVL 1	Temperature threshold level 1 of RTD 10 - °C					
21	RTD 10 LVL 2	Temperature threshold level 2 of RTD 10 - °C					
Set Menu Category: Tripping/Alarm Options							
Options Range - Set each to Enable (ENABL) or Disable (DSABL)							
Option Setting							
Item #	Function	TRIP	ALARM	AUTO RST	PANEL RST	PLC RESET	ACTIVE DURING
1	MAX START TIME						START
2	TOO MANY STARTS						START
3	U/C LEVEL 1						RUN
4	U/C LEVEL 2						RUN
5	LOAD INCREASED						RUN
6	O/C LEVEL 1-JAM						RUN
7	O/C LVL 2-SHORT						ALWAYS
8	THERMAL LEVEL 1						ALWAYS
9	THERMAL LEVEL 2						ALWAYS
10	UNBALANCE LVL 1						ALWAYS
11	UNBALANCE LVL 2						ALWAYS
12	UNDERVOLTAGE						RUN&START
13	O/V LEVEL 1						RUN&START
14	O/V LEVEL 2						RUN&START
15	PHASE LOSS						ALWAYS
16	PHASE SEQUENCE						ALWAYS
17	GND FLT LVL 1						ALWAYS
18	GND FLT LVL 2						ALWAYS
19	COMM PORT FAILED						ALWAYS
20	INTERNAL FAILURE						ALWAYS
21	CONTROL CIR OPEN	DISABLE	DISABLE				
22	WELDED CONTACTOR	DISABLE	DISABLE				
23	EXTERNAL FAULT 1						ALWAYS
24	EXTERNAL FAULT 2						ALWAYS
25	EXTERNAL FAULT 3						ALWAYS

DMP2 Protection System Settings

GEK-105499

Location _____ Motor Identification _____
 Model Number DMP2 Program Version DMP

<i>Set Menu Category: Tripping/Alarm Options (cont.)</i>							
<i>Options Range – Set each to Enable (ENABL) or Disable (DSABL)</i>							
		<i>Option Setting</i>					
<i>Item #</i>	<i>Function</i>	<i>TRIP</i>	<i>ALARM</i>	<i>AUTO RST</i>	<i>PANEL RST</i>	<i>PLC RESET</i>	<i>ACTIVE DURING</i>
26	RTD 1 - LEVEL 1						ALWAYS
27	RTD 1 - LEVEL 2						ALWAYS
28	RTD 2 - LEVEL 1						ALWAYS
29	RTD 2 - LEVEL 2						ALWAYS
30	RTD 3 - LEVEL 1						ALWAYS
31	RTD 3 - LEVEL 2						ALWAYS
32	RTD 4 - LEVEL 1						ALWAYS
33	RTD 4 - LEVEL 2						ALWAYS
34	RTD 5 - LEVEL 1						ALWAYS
35	RTD 5 - LEVEL 2						ALWAYS
36	RTD 6 - LEVEL 1						ALWAYS
37	RTD 6 - LEVEL 2						ALWAYS
38	RTD 7 - LEVEL 1						ALWAYS
39	RTD 7 - LEVEL 2						ALWAYS
40	RTD 8 - LEVEL 1						ALWAYS
41	RTD 8 - LEVEL 2						ALWAYS
42	RTD 9 - LEVEL 1						ALWAYS
43	RTD 9 - LEVEL 2						ALWAYS
44	RTD 10 - LEVEL 1						ALWAYS
45	RTD 10 - LEVEL 2						ALWAYS
46	UNDER PWR LVL 1						RUN
47	UNDER PWR LVL 2						RUN
48	LOW POWER FACTOR						RUN

DMP3 Protection System Settings

Location _____ Motor Identification _____
 Model Number **DMP3** Program Version **DMP**

Item #	Description		Setting
-	Power Supply Switch (applicable to models with ac power supply only)		
Set Menu Category: Communication Settings			
1	MOTOR NUMBER	Identification Number	
2	BAUD RATE	Communications baud rate	
3	ADDRESS NO.	Serial link address number	
4	FUTURE ENH. 1	(for future use)	NOT USED
5	FUTURE ENH. 2	(for future use)	NOT USED
6	FUTURE ENH. 3	(for future use)	NOT USED
Set Menu Category: System Parameter Settings			
1	LINE VOLTS (Vn)		
2	LINE FREQUENCY	Nominal system frequency	
3	VT PRIMARY	Rated voltage - VT primary winding	Not Connected
4	VT SECONDARY	Rated voltage - VT secondary winding	Not Connected
5	MOTOR FLC	Motor full-load current (FLC) - primary amperes	
6	CT PRIMARY	Rated primary current - phase CTs	
7	GND CT PRIMARY	Rated primary current - ground CT	
8	GND FAULT LVL 1	Ground overcurrent pickup level 1 - % of FLC	
9	G/F LVL 1 DELAY	Ground overcurrent level 1 delay - seconds	
10	GND FAULT LVL 2	Ground overcurrent pickup level 2 - % of FLC	
11	G/F LVL 2 DELAY	Ground overcurrent level 2 delay - seconds	
12	CURRENT INHIBIT	Inhibit current - % of FLC	
13	START/STP SIGNAL		
14	STARTING METHOD		
15A	MAX TIME IN START		
15B	TRANSITION TIME		
15C	STAR TO DELTA AT		
16A	LOW SPEED FLC		
16B	LOW SPD t6x TIME		
17	CONFIG OUTPUT C	Configuration of output relay C	
18	OUPUT C DELAY	Time delay of output relay C - seconds	
19	CONFIG OUTPUT D	Configuration of output relay D	
20	OUPUT D DELAY	Time delay of ouput relay D - seconds	
21	PROTECTION ONLY		YES
Set Menu Category: Voltage Settings			
1	U/V LEVEL		
2	U/V DELAY		
3	U/V STRT PREVENT		OFF
4	U/V AUTO RESTART		DISABLE
5	U/V RSTRT DELAY		
6	O/V LEVEL 1		
7	O/V LEVEL 2		
8	O/V LVL 2 DELAY		

DMP3 Protection System Settings

GEK-105499

Location _____ Motor Identification _____
 Model Number **DMP3** Program Version **DMP**

Item #	Description		Setting
Set Menu Category: Current Settings			
1	MAX START TIME	Maximum motor starting time allowed – seconds	
2	NUMBER OF STARTS	Maximum number of starts allowed within STARTS PERIOD	
3	STARTS PERIOD	Time period for NUMBER OF STARTS – minutes	
4	START INHIBIT		
5	U/C LEVEL 1	Undercurrent threshold level 1 – % of FLC	
6	U/C LEVEL 1 DELAY	Time delay for U/C LEVEL 1 function – seconds	
7	U/C LEVEL 2	Undercurrent threshold level 2 – % of FLC	
8	U/C LEVEL 2 DELAY	Time delay for U/C LEVEL 2 function – seconds	
9	LOAD INCREASE	Threshold level of Load Increase function – % of FLC	
10	O/C LEVEL 1 - JAM	Overcurrent threshold level 1 – % of FLC	
11	O/C LVL 1 DELAY	Time delay of O/C LEVEL 1 function – seconds	
12	O/C LEVEL 2 - SHORT	Overcurrent threshold level 2 – % of FLC	
13	O/C LVL 2 DELAY	Time delay of O/C LEVEL 2 function – seconds	
14	OVERLOAD PICKUP	Pickup level of thermal overload function – % of FLC	
15	THERMAL LEVEL 1	Operate level 1 of thermal overload function – % of Thermal Capacity	
16	t6x TIME	t6x time factor of thermal overload function – seconds	
17	HOT/COLD RATIO	Thermal capability of Hot motor in % of capability of Cold motor	
18	COOL TIME FACTOR	Ratio of cooling time constant of stopped motor to running motor	
19	STALL TIME FCTR	Heating time constant of stopped motor as % of running motor	
20	ENHANCED STRT:dI	Decrement in current during motor start – % of stall current	
21	ENHANCED STRT:dT	Time window for ENHANCED STRT:dI setting – seconds	
22	UNBALANCE LVL 2	Unbalance current threshold level 2 – %	
23	U/B LVL 2 MAX T	Operate time at unbalance current of 10% – seconds	
Set Menu Category: Power Settings			
1	RATED PF AT FLC		
2	UNDER PWR LVL 1		
3	U/P LVL 1 DELAY		
4	UNDER PWR LVL 2		
5	U/P LVL 2 DELAY		
6	LOW POWER FACTOR		
7	LOW PF DELAY		
Set Menu Category: Temperature Settings			
1	RTD TYPE	Type of RTDs used	
2	RTD 1 LVL 1	Temperature threshold level 1 of RTD 1 – °C	
3	RTD 1 LVL 2	Temperature threshold level 2 of RTD 1 – °C	
4	RTD 2 LVL 1	Temperature threshold level 1 of RTD 2 – °C	
5	RTD 2 LVL 2	Temperature threshold level 2 of RTD 2 – °C	
6	RTD 3 LVL 1	Temperature threshold level 1 of RTD 3 – °C	
7	RTD 3 LVL 2	Temperature threshold level 2 of RTD 3 – °C	
8	RTD 4 LVL 1	Temperature threshold level 1 of RTD 4 – °C	
9	RTD 4 LVL 2	Temperature threshold level 2 of RTD 4 – °C	

DMP3 Protection System Settings

Location _____ **Motor Identification** _____
Model Number DMP3 **Program Version** DMP

Item #	Description		Setting				
Set Menu Category: Temperature Settings (cont.)							
10	RTD 5 LVL 1	Temperature threshold level 1 of RTD 5 - °C					
11	RTD 5 LVL 2	Temperature threshold level 2 of RTD 5 - °C					
12	RTD 6 LVL 1	Temperature threshold level 1 of RTD 6 - °C					
13	RTD 6 LVL 2	Temperature threshold level 2 of RTD 6 - °C					
14	RTD 7 LVL 1	Temperature threshold level 1 of RTD 7 - °C					
15	RTD 7 LVL 2	Temperature threshold level 2 of RTD 7 - °C					
16	RTD 8 LVL 1	Temperature threshold level 1 of RTD 8 - °C					
17	RTD 8 LVL 2	Temperature threshold level 2 of RTD 8 - °C					
18	RTD 9 LVL 1	Temperature threshold level 1 of RTD 9 - °C					
19	RTD 9 LVL 2	Temperature threshold level 2 of RTD 9 - °C					
20	RTD 10 LVL 1	Temperature threshold level 1 of RTD 10 - °C					
21	RTD 10 LVL 2	Temperature threshold level 2 of RTD 10 - °C					
Set Menu Category: Tripping/Alarm Options							
Options Range - Set each to Enable (ENABL) or Disable (DSABL)							
Option Setting							
Item #	Function	TRIP	ALARM	AUTO RST	PANEL RST	PLC RESET	ACTIVE DURING
1	MAX START TIME						START
2	TOO MANY STARTS						START
3	U/C LEVEL 1						RUN
4	U/C LEVEL 2						RUN
5	LOAD INCREASED						RUN
6	O/C LEVEL 1-JAM						RUN
7	O/C LVL 2-SHORT						ALWAYS
8	THERMAL LEVEL 1						ALWAYS
9	THERMAL LEVEL 2						ALWAYS
10	UNBALANCE LVL 1						ALWAYS
11	UNBALANCE LVL 2						ALWAYS
12	UNDERVOLTAGE	DISABLE	DISABLE				
13	O/V LEVEL 1	DISABLE	DISABLE				
14	O/V LEVEL 2	DISABLE	DISABLE				
15	PHASE LOSS	DISABLE	DISABLE				
16	PHASE SEQUENCE	DISABLE	DISABLE				
17	GND FLT LVL 1						ALWAYS
18	GND FLT LVL 2						ALWAYS
19	COMM PORT FAILED						ALWAYS
20	INTERNAL FAILURE						ALWAYS
21	CONTROL CIR OPEN	DISABLE	DISABLE				
22	WELDED CONTACTOR	DISABLE	DISABLE				
23	EXTERNAL FAULT 1						ALWAYS
24	EXTERNAL FAULT 2						ALWAYS
25	EXTERNAL FAULT 3						ALWAYS

DMP3 Protection System Settings

GEK-105499

Location _____ **Motor Identification** _____
Model Number DMP3 **Program Version** DMP

Set Menu Category: Tripping/Alarm Options (cont.)							
Options Range - Set each to Enable (ENABL) or Disable (DSABL)							
		Option Setting					
Item #	Function	TRIP	ALARM	AUTO RST	PANEL RST	PLC RESET	ACTIVE DURING
26	RTD 1 - LEVEL 1						ALWAYS
27	RTD 1 - LEVEL 2						ALWAYS
28	RTD 2 - LEVEL 1						ALWAYS
29	RTD 2 - LEVEL 2						ALWAYS
30	RTD 3 - LEVEL 1						ALWAYS
31	RTD 3 - LEVEL 2						ALWAYS
32	RTD 4 - LEVEL 1						ALWAYS
33	RTD 4 - LEVEL 2						ALWAYS
34	RTD 5 - LEVEL 1						ALWAYS
35	RTD 5 - LEVEL 2						ALWAYS
36	RTD 6 - LEVEL 1						ALWAYS
37	RTD 6 - LEVEL 2						ALWAYS
38	RTD 7 - LEVEL 1						ALWAYS
39	RTD 7 - LEVEL 2						ALWAYS
40	RTD 8 - LEVEL 1						ALWAYS
41	RTD 8 - LEVEL 2						ALWAYS
42	RTD 9 - LEVEL 1						ALWAYS
43	RTD 9 - LEVEL 2						ALWAYS
44	RTD 10 - LEVEL 1						ALWAYS
45	RTD 10 - LEVEL 2						ALWAYS
46	UNDER PWR LVL 1	DISABLE	DISABLE				
47	UNDER PWR LVL 2	DISABLE	DISABLE				
48	LOW POWER FACTOR	DISABLE	DISABLE				