

INSTRUCTIONS

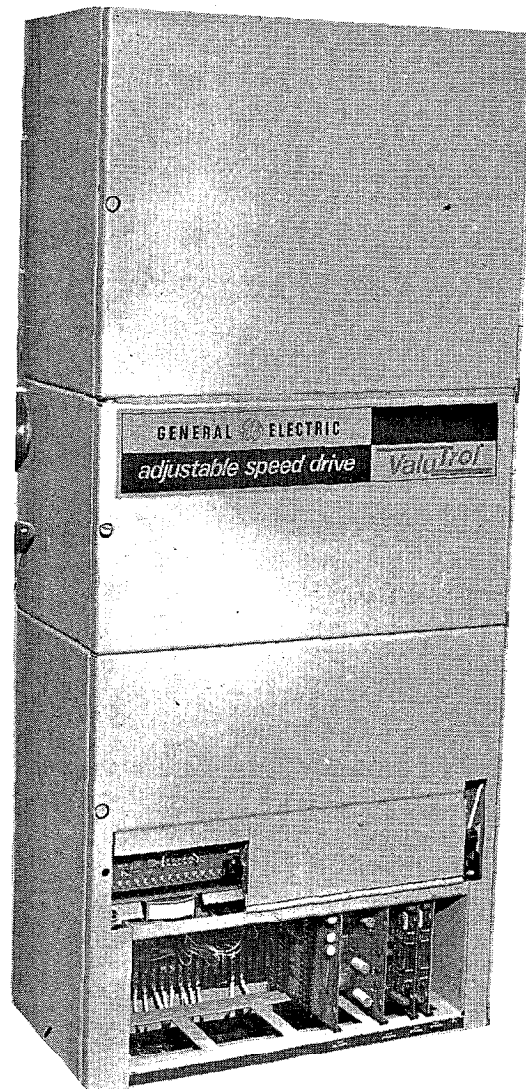

ValuTrol* INDUSTRIAL DRIVE SYSTEM FULL WAVE REGENERATIVE

INSTALLATION — OPERATION — MAINTENANCE



(MG-5368-6)

These instructions do not purport to cover all details or variations in equipment nor to provide for every possible contingency to be met in connection with installation, operation or maintenance. Should further information be desired or should particular problems arise which are not covered sufficiently for the purchaser's purposes, the matter should be referred to General Electric Company.

GENERAL  **ELECTRIC**

TABLE OF CONTENTS

	<u>Page</u>
Introduction	5
Receiving, Handling and Storage	5
Safety for Personnel and Equipment	5
Installation	6
Maintenance	8
Instruction Information	10
Types of Diagrams	10
General Description	10
Basic Description	10
Basic Elements	10
Power Supply Card	10
Main Control Card	10
Auxiliary Control Card	12
Motor field Control Card	12
Motor Field Exciter Card	12
Interface Card	14
Diagnostic Card	15
Control Fuses and MOV's	15
Power Connections	15
Signal Connections	15
Start-Up	16
Sequence of Operation	19
Power Applied	19
Start	19
Stop	27
Diagnostic Static	27
Diagnostic Run	28
Calibration	28
Calibration with Motor Field Control	29
Calibration with Motor Field Exciter	31
Troubleshooting	32
Removal/Repair	33
Conversion Module	33
Fans	34
SCR Replacement	35
Stud Mount	35
Press Pak*	35
Glossary of Terms	37, 38, 39

* Trademark of General Electric Company, U.S.A.



INSTRUCTIONS

GEK-24988A

ERRATA SHEET NUMBER 01
AUGUST 12, 1981

VALUTROL* INDUSTRIAL DRIVE SYSTEM Full Wave Regenerative

This Errata Sheet affects instruction book GEK-24988A dated 12/77/ It should be attached to and retained as a part of this publication.

This instruction book text should be changed in accordance with information contained in this Errata Sheet.

Page 30

Change MAX SPEED/ALIGN paragraph to read:

Turn MAX SPEED/ALIGN full CW. Adjust the LOC REF potentiometer until CEMF reads -5 volts ($\pm 10\%$). Adjust MAX SPEED until SFB corresponds to the base speed feedback on the test data sheet.

These instructions do not purport to cover all details or variations in equipment nor to provide for every possible contingency to be met in connection with installation, operation or maintenance. Should further information be desired or should particular problems arise which are not covered sufficiently for the purchaser's purposes, the matter should be referred to General Electric Company.

GENERAL  ELECTRIC

LIST OF ILLUSTRATIONS

<u>Figure</u>	<u>Page</u>
1. Valutrol Power Unit	6
2. Valutrol Block Diagram	9
3. Valutrol Power Unit (door open).	11
4. Power Supply Card	12
5. Main Control Card	13
6. Interface Card	14
7. Auxiliary Control Card	15
8. Modification Rack	15
9. Motor Field Control Card.	16
10. Motor Field Exciter Card	16
11. Signal and Power Connections	17
12. Diagnostic Card and Lower Portion of Main Control Card	20
13. Test Data Sheet.	22
Wave Form Illustrations	23
14. Current Feedback (CFB) at Low Current Level	23
15. Current Feedback (CFB) at Continuous Current Level	23
16. Voltage Feedback (VFB) at Low Current and 200 Volts.	23
17. Voltage Feedback (VFB) at Continuous Current and 200 Volts	23
18. Oscillator (OSC).	24
19. Initial Pulse (IPU)	24
20. Synchronizing Signal (SA).	24
21. Speed Feedback Signal (SFB) with AC Tachometer 450 RPM	24
22. Tachometer Feedback Signal (TFB) with AC Tachometer 450 RPM	25
23. Tachometer Feedback Signal (TFB) with AC Tachometer 3160 RPM.	25
24. Speed Feedback Signal (SFB) with AC Tachometer 3160 RPM	25
25. Pulse Output (PO).	25
26. Gate to Cathode Firing Signal.	26
27. Diagnostic Test Circuits	28
28. Gain Adjustment.	31
29. Removal of Gate Leads.	34
30. Removal of Slotted Spacer	34
31. Removal of Conversion Module	34
32. Removal of Fans	34
33. Press Pak Heat Sink (Top View).	35
34. Stud Mount Heat Sink (Top View).	35
35. Stud Mount Heat Sink (Front View)	35
36. Press Pak Heat Sink (Front View)	35

LIST OF TABLES

<u>Table</u>		<u>Page</u>
I.	Relationships between air temperature, relative humidity and dew point	5
II.	Recalibrating adjustment sequences	29
III.	Signal connections	18
IV.	Fault conditions	21

INTRODUCTION

This Instruction Book contains helpful suggestions for placing the Valutrol drive equipment in service. It contains general information about drive operation and maintenance.

The operator and maintenance man should have access to a copy of this instruction book.

Additional instructions are included in the supplementary instruction publications and diagrams included in the instruction folder with the equipment.

RECEIVING, HANDLING AND STORAGE

RECEIVING

The equipment should be placed under adequate cover immediately upon receipt as packing cases are not suitable for out-door or unprotected storage. Each shipment should be carefully examined upon arrival and checked with the packing list. Any shortage or damage should be reported promptly to the carrier. If required, assistance may be requested from General Electric Company Speed Variator Products Operation, Erie, Pa. When seeking assistance please use requisition number and model number to identify the equipment. **Telephone 814-455-3219**

HANDLING

Wall mounted power units can be transported by lift trucks with the forks completely under the base using care that the unit does not tip.

STORAGE

If the equipment is not to be installed immediately, it should be stored in a clean, dry location at ambient temperatures from -20°C (-4°F) to $+55^{\circ}\text{C}$ (131 F). The surrounding air must be free of chemical and electrically conductive or corrosive contaminants.

Precautions should be taken to prevent condensation from forming within the equipment enclosure. If the storage environment exceeds a 15°C (27°F) drop in temperature at 50% humidity over a 4 hour period, a space heater should be installed inside each enclosure to prevent condensation. (A 100 watt lamp can sometimes serve as a substitute source of heat). Higher humidities with smaller temperature changes will also cause condensation.

Condensation occurs when air containing some moisture is cooled below its dew point. The dew point represents saturation of the air, and is the temperature at which the moisture starts to condense into water. It is not a fixed temperature but rather is related to the initial temperature of the air and its relative humidity at that temperature. The amount of moisture that can be held in the air is related to the air temperature. The following examples illustrate some of these relationships.

TABLE I

**Relationship Between Air Temperature,
Relative Humidity and Dew Point**

AIR TEMP °F	°C	RELATIVE HUMIDITY %	WGT. OF MOISTURE IN 1 LB OF DRY AIR. GRAINS	DEW POINT	
				°F	°C
104	40	100	345	104	40
104	40	80	270	97	36
104	40	40	130	75	24
104	40	10	32	37	3
50	10	100	54	50	10
50	10	80	42	43	6
50	10	40	21	25	4

In industrial drives, condensation is a possibility in applications where air temperature changes are large and rapid and/or the air is moist. For example, an outdoor crane operating in sunshine on a winter day, which then is shut down and parked in the shade will experience a rapid drop in temperature. This can result in condensation inside the equipment. Adding heat to keep the air temperature above its dew point can prevent condensation.

If storage temperatures below -20°C (-4°F) are likely to be present then auxiliary heat should be added in each enclosure to maintain temperature at or above -20°C . For assistance in heater size selection contact General Electric Company.

When a drive that has been in operation is shut down for either a short or extended period of time, it is recommended the environmental conditions be maintained the same as when in operation. Power, ventilation or heating and air-conditioning (if used) should be left on during the downtime to prevent large changes in temperature and possible moisture condensation.

SAFETY FOR PERSONNEL AND EQUIPMENT

The following paragraphs list some general safety reminders and safety recommendations to be followed when operating or installing this equipment.

WARNING

DENOTES OPERATING PROCEDURES AND PRACTICES THAT MAY RESULT IN PERSONAL INJURY OR LOSS OF LIFE IF NOT CORRECTLY FOLLOWED.

COLOR — BLACK OR WHITE LETTERING ON RED FIELD.

CAUTION

DENOTES OPERATING PROCEDURES AND PRACTICES THAT, IF NOT STRICTLY OBSERVED MAY RESULT IN DAMAGE TO, OR DESTRUCTION OF, THE EQUIPMENT.

COLOR – BLACK LETTERING ON AMBER FIELD.

NOTE

DENOTES AN OPERATING PROCEDURE OR CONDITION WHICH SHOULD BE HIGHLIGHTED.

COLOR – BLACK LETTERING ON A WHITE FIELD.

WARNING

IMPROPER LIFTING PRACTICES CAN CAUSE SERIOUS OR FATAL INJURY.

LIFT ONLY WITH ADEQUATE EQUIPMENT AND TRAINED PERSONNEL.

WARNING: HIGH VOLTAGE

ELECTRIC SHOCK CAN CAUSE PERSONAL INJURY OR LOSS OF LIFE. CIRCUIT BREAKERS, IF SUPPLIED AS PART OF THE TOTAL SYSTEM, MAY NOT DISCONNECT ALL POWER TO THE EQUIPMENT. SEE SYSTEM ELEMENTARY DIAGRAMS. WHETHER THE AC VOLTAGE SUPPLY IS GROUNDED OR NOT, HIGH VOLTAGE TO GROUND WILL BE PRESENT AT MANY POINTS. WHEN INSTRUMENTS SUCH AS OSCILLOSCOPES ARE USED TO WORK ON LIVE EQUIPMENT, GREAT CAUTION MUST BE USED. WHEN ONE OF THE INSTRUMENT LEADS IS CONNECTED TO THE CASE OR OTHER METAL PARTS OF THE INSTRUMENT, THIS LEAD SHOULD NOT BE CONNECTED TO AN UNGROUNDED PART OF THE SYSTEM UNLESS THE INSTRUMENT IS ISOLATED FROM GROUND AND ITS METAL PARTS TREATED AS LIVE EQUIPMENT. USE OF AN INSTRUMENT HAVING BOTH LEADS ISOLATED FROM THE CASE PERMITS GROUNDING OF THE CASE EVEN WHEN MEASUREMENTS MUST BE MADE BETWEEN TWO LIVE PARTS.

CAUTION

DO NOT REMOVE PRINTED CIRCUIT CARDS FROM THE EQUIPMENT WHILE POWER IS APPLIED. THIS CAN DAMAGE THE EQUIPMENT.

NOTE

ALWAYS READ THE COMPLETE INSTRUCTIONS PRIOR TO APPLYING POWER OR TROUBLESHOOTING THE EQUIPMENT. FOLLOW THE START UP PROCEDURE STEP BY STEP.

READ AND HEED ALL WARNING, CAUTION AND NOTE LABELS POSTED ON THE EQUIPMENT.

CAUTION

DO NOT REMOVE INPUT POWER FROM THE DRIVE UNTIL IT HAS FULLY EXECUTED A STOP SEQUENCE, AS THIS CAN DAMAGE THE

DRIVE SYSTEM.

INSTALLATION

LOCATION

DC-SCR drive power units are suitable for most factory areas where other industrial equipment is installed. They should be installed in well ventilated areas with ambient temperatures ranging from 0°C (32°F) to 40°C (104°F) and relative humidities up to 90 percent. It should be recognized; however, that since the life expectancy of any electronic component decreases with increased ambient temperature, reduction of the ambient temperature will bring about extended component life. For example, longer component life should be expected if the ambient temperature is held between 20°C (68°F) and 30°C (87°F).

Proper performance and normal operational life can be expected by maintaining a proper environment for the drive system.

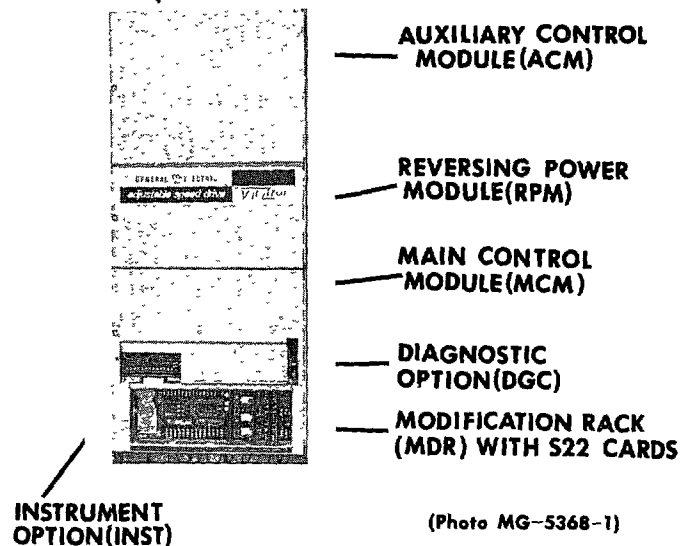

Figure 1. Valutrol Power Unit

Environments which include excessive amounts of one or more of the following characteristics should be considered hostile to drive performance and life:

1. Dirt, dust and foreign matter.
2. Vibration and shock.
3. Moisture and vapors.
4. Temperature excursions.
5. Caustic fumes.
6. Power line fluctuations.
7. Electromagnetic interference (noise).

Totally enclosed power units should be positioned to permit heat radiation from all surfaces except the bottom; otherwise, the enclosure can be positioned as follows:

A wall mounted power unit enclosure (or floor mounted enclosure) may be placed side by side with another enclosure. Clearance at least equal to the width of the enclosure should be available in front so that the door may be fully opened for easy access.

WARNING

SOME POWER UNITS ARE FURNISHED WITH PARTIAL ENCLOSURES OPEN AT TOP AND BOTTOM. THESE ARE INTENDED ONLY FOR MOUNTING IN ANOTHER ENCLOSURE OR IN A CONTROL ROOM HAVING ACCESS BY QUALIFIED PERSONNEL ONLY. EXPLOSIONS OR FIRES MIGHT RESULT FROM MOUNTING DRIVE POWER UNITS IN HAZARDOUS AREAS SUCH AS LOCATIONS WHERE INFLAMMABLE OR COMBUSTIBLE VAPORS OR DUSTS ARE PRESENT. DRIVE POWER UNITS SHOULD BE INSTALLED AWAY FROM HAZARDOUS AREAS, EVEN IF USED WITH DC MOTORS SUITABLE FOR USE IN SUCH LOCATIONS.

MOUNTING

Wall mounted enclosures may be mounted on any firm, reasonably flat, vertical surface.

NOTE

FOUR HOLES (ONE IN EACH REAR CORNER) ARE PROVIDED FOR MOUNTING THE POWER UNIT. THE BOTTOM LEFT HAND MOUNTING HOLE IS COVERED BY A WIRE BUNDLE. TO GAIN ACCESS TO THIS HOLE, PULL ON THE TAIL ATTACHED TO THE HARNESS AND IT WILL POP DOWN OUT OF THE WAY. AFTER THE POWER UNIT HAS BEEN INSTALLED, POP THE HARNESS BACK INTO PLACE.

An optional mounting arrangement is also available which consists of two external brackets (one at the top rear and one at the bottom rear of the power unit enclosure). Each bracket is fitted with two mounting holes for external mounting of the wall mounted enclosure.

CONNECTIONS

All internal electrical connections between components in DC-SCR drive power units are made at the factory of General Electric Company.

Be sure to protect the interior panel mounted components and sub-assemblies from metal particles when cutting or drilling entrances for interconnecting wiring and cables.

If additional relays, contactors, or electrical solenoids are added in the proximity of the SCR equipment enclosure, RC suppression networks should

be added across the coils. A series combination of a 220 ohm resistor and a 0.5mfd capacitor in parallel with the relay coils is recommended.

NOTE

SOME SYSTEM TRANSFORMERS AND OTHER APPARATUS ARE SHIPPED SEPARATELY AND MUST BE MOUNTED AND CONNECTED TO THE SYSTEM.

WARNING

ALL MOTOR BASES AND EQUIPMENT ENCLOSURE HOUSINGS SHOULD BE CONNECTED TO THE FACTORY OR FACILITY EARTH GROUNDING SYSTEM.

NOTE

IT IS RECOMMENDED THAT THE DRIVE SYSTEM COMMON CIRCUIT BE GROUNDED AT ONLY ONE POINT. THIS MEANS THAT IF THE DRIVE REFERENCE IS SUPPLIED BY A NUMERICAL CONTROL OR PROCESS INSTRUMENT WITH GROUNDED COMMON, THE DRIVE COMMON SHOULD NOT BE GROUNDED. IF A SEPARATE POWER TRANSFORMER IS USED AND IF THE SECONDARY OF THE TRANSFORMER MUST BE GROUNDED, IT IS RECOMMENDED THAT HIGH RESISTANCE GROUNDING BE USED.

CAUTION

INSTALLATION WIRING MUST BE IN ACCORDANCE WITH THE NATIONAL ELECTRICAL CODE AND BE CONSISTENT WITH ALL LOCAL CODES. SECONDARIES OF 115 VOLT CONTROL TRANSFORMERS TYPICALLY HAVE ONE SIDE FUSED AND THE OTHER GROUNDED OR AVAILABLE FOR GROUNDING BY THE USER.

CAUTION

MEGGERING CAN DAMAGE ELECTRONIC COMPONENTS. DO NOT MEGGER OR HI-POT WITHOUT CONSULTING THE SPEED VARIATOR PRODUCTS OPERATION, GENERAL ELECTRIC CO.

CAUTION

DO NOT CONNECT ANY EXTERNAL CIRCUITS OTHER THAN SHOWN ON THE ELEMENTARY DIAGRAM, SUCH AS AMMETERS ON THE SHUNT OR VOLTMETERS ON THE TACHOMETER BECAUSE THE PERFORMANCE OF THE DRIVE SYSTEM MAY BE DEGRADED.

CAUTION

DO NOT USE POWER FACTOR CORRECTION CAPACITORS WITH THIS EQUIPMENT WITHOUT CONSULTING THE SPEED VARIATOR PRODUCTS OPERATION, GENERAL ELECTRIC CO. DAMAGE MAY RESULT FROM HIGH VOLTAGES GENERATED WITH CAPACITORS ARE SWITCHED.

Before power is applied to the drive system, checks should be made to see that all internal connections are tight, that plug in printed circuit cards in the optional regulator rack are fully seated and that all open relays and contactors operate freely by hand. Check that the equipment is clean and that no metal chips are present.

MAINTENANCE

Periodically inspect and maintain the equipment protective devices (particularly air filters when supplied) per instructions in this section. Check all electrical connections for tightness; look for signs of poor connections and over heating (arcing or discoloration).

FANS AND FILTERS

On force ventilated drives, the power unit contains a fan and perhaps an air filter in the intake of the enclosure and/or on equipment inside the enclosure.

Inspect the fan at regular intervals to see that it is operating properly. Check for excessive noise and vibration, loose fan blades and for over heating of the motors. Keep the fan blades clean.

If the fan does not operate, replace the fan and integral motor with a unit with the same catalog number.

Clean and/or replace air filter as appropriate depending on the accumulation of dirt for the type supplied.

To clean metal filters, flush only with warm water, dry and recoat lightly with RP[®] Super Filter Coat or equivalent (light oil) or replace the filter.

Be sure to install filters with air flow direction as indicated on the filter.

DC MOTORS

Maintenance instructions covering brushes, commutator and lubrication are in GEK-2304 which is found elsewhere in the instruction book.

PRINTED CIRCUIT CARDS

Printed circuit cards normally do not require maintenance except to keep them clean and tightly secured to their respective terminal boards or tightly plugged in the optional modification rack receptacles. Clean as follows:

1. Dry Dust – Vacuum clean, then blow with dry filtered compressed air (low pressure supply).
2. Oily Dirt – Certain components (electrolytic capacitors, switches, meters, potentiometers and transformers can be damaged by solvent, so its use is not recommended. If absolutely necessary, use solvent sparingly on a small brush and avoid above components. Clean contact terminals with dry non-linting cloth after solvent has been used. Recommended solvents: Freon* RE or TF.
3. If the card is badly contaminated or corroded, replace.

SILICON CONTROLLED RECTIFIERS

Keep SCR's and heatsink free from dirt, oil or grease, since any accumulation of dirt may cause overheating. Clean as follows:

1. Dry Dust – Vacuum clean, then blow with dry, filtered compressed air (low pressure).

CAUTION

SOLVENT CAN HARM NON-METAL COMPONENTS.

2. Oil Dirt – Use dry or barely moist (with solvent) non-linting cloth. Repeat until cloth remains clean. All contact tips must be cleaned with dry non-linting cloth after solvent has been used. Recommended solvents: Freon RE or TF.

CONTROL DEVICES

Inspect all relays and contactors at regular intervals and keep them free from dirt, oil or grease. Check for freedom of moving parts, corrosion, loose connections, worn or broken parts, charred insulation or odor, proper contact pressure and remaining wear allowance on contacts. Do not lubricate the contacts as lubrication shortens their life.

Both copper and silver contacts will become darkened and somewhat roughened in normal operation. This does not interfere with their performance, and does not indicate that the contacts should be filed. In general, contacts will not need attention during their normal life, but if prominent beads form on the surfaces due to severe arcing, the contact faces may be dressed with a fine file. Do not use sand paper or emery cloth.

Any contact that is worn to the point where contact wipe or pressure is lost should be replaced. Contactor shunts which are badly frayed or broken should also be replaced.

Cleaning procedure is the same as previously given for SCR and heatsink.

*Trademark of E. I. DuPont Co.

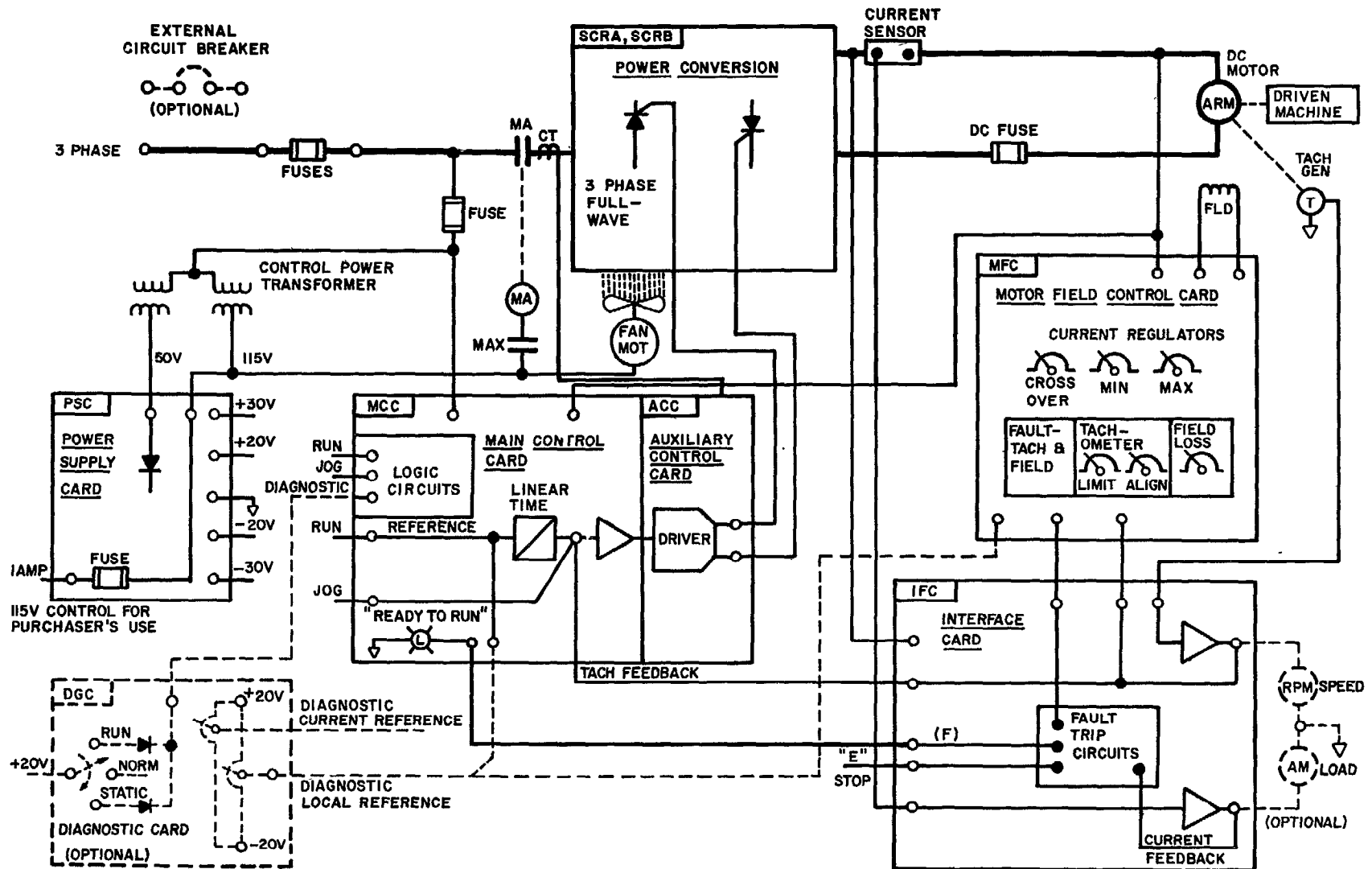

Figure 2. Valutrol Drive Block Diagram

INSTRUCTION INFORMATION

The instruction folder furnished with the equipment includes detailed instructions and diagrams applicable for each specific drive system.

In addition to this general instruction the folder includes instruction for the motor(s) and other components furnished. Start-up and troubleshooting guides are included. All instructions and the accompanying diagrams should be consulted before applying power to the system.

THE FOLLOWING INFORMATION IS OF PARTICULAR IMPORTANCE.

TYPES OF DIAGRAMS

Different types of control diagrams are provided for specific purposes. The type of control diagram is noted in the title block of each diagram sheet.

The three major types of diagrams are Elementary, (sometimes called schematic), Layout or Connection and Interconnection.

The Elementary diagrams represents (in symbolic form) the fundamental operation and relationship of the electrical parts of a system. These diagrams are drawn in such a manner that the operation of the control system is easily understood. Mechanical relationships of control devices are subordinated to simple presentation of the electrical circuits. Connections made between control devices and power devices within the enclosure are also shown in this type of diagram.

The Layout or Connection diagram, when supplied is one which shows the relative physical position of the devices as well as other electrical components located within the same enclosure.

The elementary diagram also identifies adjustments, signals and test points. In this instruction book, adjustments are CAPITALIZED and UNDERLINED. Example: FMAX (Maximum motor field adjustment).

Signals and test points are CAPITALIZED only, Example: CFB (Current Feed back).

In many cases the Elementary diagram will be combined with the Interconnection diagram. On more complicated system a separate Interconnection diagram will be furnished, which will show the type and number of connections to be made between major components of the system such as the power unit, motor, operator's station, the plant power source, auxiliary devices and other electrical machines. In some cases the Interconnection information may be presented in tabular form.

GENERAL DESCRIPTION

Power is fed through the fuses (and optional external circuit breaker), the MA contactor, through current transformers, and enters the power conversion modules (SCRA and SCRB) where it is converted to DC adjustable voltage. DC current is fed through a shunt and a DC fuse to the DC motor armature.

The basic elements of the full wave, regenerative, Valutrol, DC SCR drive are shown in the simplified block diagram. Fig. 2.

The Speed of the motor is proportional to the DC voltage applied to its armature. Speed is measured by a tachometer generator directly connected to the DC motor.

The remainder of the control is manufactured on six (6) removable printed circuit boards. These are the power supply card (PSC), the main control card (MCC), the auxiliary control card (ACC), the interface card (IFC), the motor field card (MFC), or motor field exciter (MFE), and the diagnostic card (DGC) (optional).

Signal level power for the control is taken from the three phase input through control fuses to the control power transformer (CPT). This transformer is fitted with two isolated secondary windings: (1) 115V AC to operate the coil of the MA contactor, the conversion module cooling fans (if required) and the requirements (if any) for the modification rack (MDR); (2) the second winding is a 50 volt tapped secondary which provides the AC input to the power supply card.

POWER SUPPLY CARD (PSC)

The power supply card rectifies the AC input and provides regulated plus and minus 20 volts for the printed circuit cards. Unregulated plus and minus 30 volts DC is also provided to drive the static logic switches and the "control on" function. All of the DC outputs are fused to protect the power supply card against overloads. The regulated plus and minus 20V DC outputs are protected against over voltage conditions caused by a power supply card failure.

MAIN CONTROL CARD (MCC)

The primary purpose of the main control card is to drive the conversion modules (SCRA and SCRB) as commanded by the speed reference and feedback signals. Connection to the SCR gates is by way of the auxiliary control card (ACC).

This card also performs several additional functions such as linear timing of the reference; current limit; "Ready to Run" indicator, and various scaling and trimming adjustments.

1. FUSE
2. LINE CONTACTOR
3. SHUNT (HIDDEN)
4. DC FUSE
5. MOV/CONTROL FUSES
6. HEATSINK MODULES
7. FANS
8. MODULE TERMINAL BOARD (MTB)
9. INTERFACE CARD (IFC)
10. POWER SUPPLY (PSC)
11. 2TB
12. 3TB
13. MOTOR FIELD CONTROL (MFC)
OR MOTOR FIELD EXCITER (MFE)
14. MOTOR FIELD TERMINAL BOARD (MFTB)
15. S-22 CARDS
16. MODIFICATION RACK (MDR)
17. RACK TERMINAL BOARD (RTB)
18. MAIN CONTROL CARD (MCC)
19. HIGH VOLTAGE SHIELD
20. AUXILIARY CONTROL CARD
21. TEST RECORD
22. NAMEPLATE
23. 4TB (SIDE WALL MOUNTED)

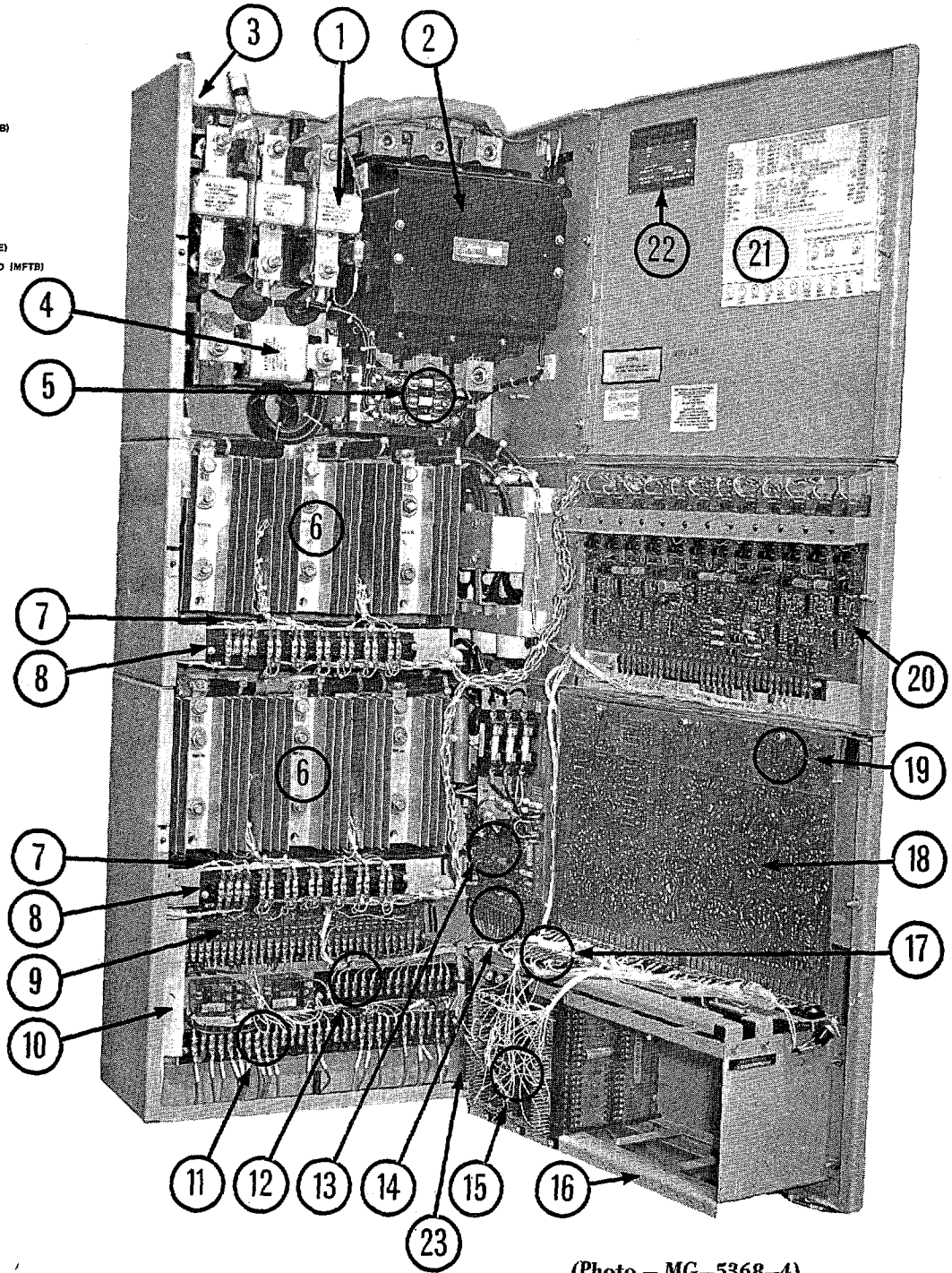

(Photo - MG-5368-4)

Figure 3. Valutrol Power Unit (Door Open)

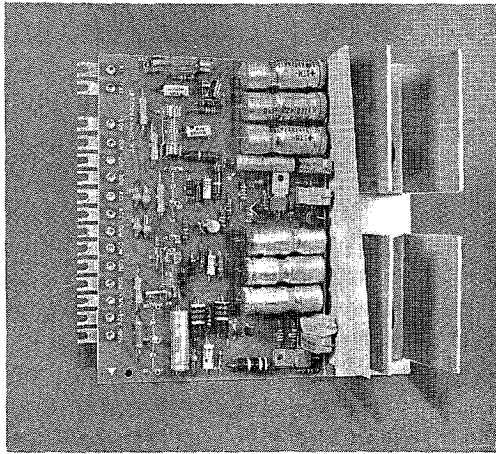

(Photo MG-5236-20)

Figure 4. Power Supply Card

A total of twelve (12) potentiometers are provided on this card, ten (10) of which are accessible from the front of the controller. The eleventh potentiometer, the card zero adjustment ZERO ADJ, is preset at the factory and should normally not be disturbed. The twelfth potentiometer is the line impedance compensation adjustment, LINE. The ten accessible potentiometers are:

<u>DAMP</u>	<u>MAX SPEED</u>	<u>MIN SPEED</u>
<u>CUR LIMIT</u>	<u>GAIN</u>	<u>REF SCALE</u>
<u>CEMF LIMIT</u>	<u>RESPONSE</u>	<u>LIN TIME</u>
<u>COMP</u>		

When the drive is first placed into operation the actual top speed may be different from what might be expected due to minor variations between tachometers. By adjusting the MAX SPEED potentiometer, any variations between tachometers can be eliminated without disturbing any other adjustments in the drive.

AUXILIARY CONTROL CARD (ACC)

The primary function of this card is to combine phase control signals, leg current signals, and oscillator signals and amplify the resulting pulse trains and direct them to the appropriate SCR gates by way of twelve (12) pulse transformers. One secondary function is to scale the output of three (3) current transformers (CT's) in the three phase AC power inputs to the conversion modules (SCRA and SCRB).

Another function is to detect circulating overcurrent faults which would not be detected by the shunt in the motor armature loop.

An additional function is to generate a trip signal which suppresses SCR firing, executes a system fault, and may be used to operate an optional shunt trip circuit breaker.

TEST INSTRUMENT AND PROBE (OPTIONAL)

Located below the main control card (to the left) is a test instrument and probe that can be used to read out signals from any of the drive test points. The probe is fitted with two connections, one for the 4 volt instrument scale and the other for the 20 volt scale. Always apply the 20 volt connection first. If the reading is below 4 volts, switch to the 4 volt connection for improved accuracy of the read out.

MOTOR FIELD CONTROL CARD (MFC) (OPTIONAL)

This card provides a current regulated field supply for the DC motor. Constant excitation is supplied in the constant torque range, as armature voltage is increased from zero to rated voltage. A cross-over, CROSS adjustment is provided at which time the motor field current is automatically decreased thereby increasing the speed of the motor above base speed. In this range the drive characteristic changes from constant torque to constant horsepower.

Other functions performed by this card include a tachometer monitor circuit to detect the loss of tachometer voltage and to detect reversed polarity when a DC tachometer is employed. Loss of motor field is also detected by this card. All of these conditions will shut down the drive. A field economy circuit is controlled by circuits on the main control card.

MOTOR FIELD EXCITER CARD (MFE)

The motor field exciter card provides a fixed value of field excitation for use with constant torque drives. However, this value of voltage is directly related to ac line voltage variations. A field loss circuit similar to the circuit on the motor field control card (MFC) is also provided.

INTERFACE CARD (IFC)

The primary purposes of the interface card are:

1. To provide low level isolated signals corresponding to the three phase AC DC armature voltage, armature and tachometer feedback.
2. To control the start, stop and synchronizing of the drive while monitoring the system for abnormal operating conditions.
3. To provide one milliamperere signals for external speed and current indication.

Other outputs provide:

1. A NO/NC contact indicating MA closure (MAX)
2. A NO contact indicating a fault condition (FLT)

For those drives employing an AC tachometer an output whose frequency is proportional to RPM is generated which may be used to drive a digital counter. AC tachometer furnished by the factory will generate 18 pulses for each revolution.

There are (4) potentiometers on this card.

1. The IZERO is a bias adjustment for the current feedback output and is factory set. This control should not be disturbed.
2. R STOP is the drop out level of the regenerative stop sequencing circuit and is also factory set.
3. IMET is the calibration adjustment for the current indicator.
4. SMET is the calibration adjustment for the speed indicator.

Adjustments 3 and 4 will be factory set if the indicators are ordered with the drive and mounted in the power unit enclosure.

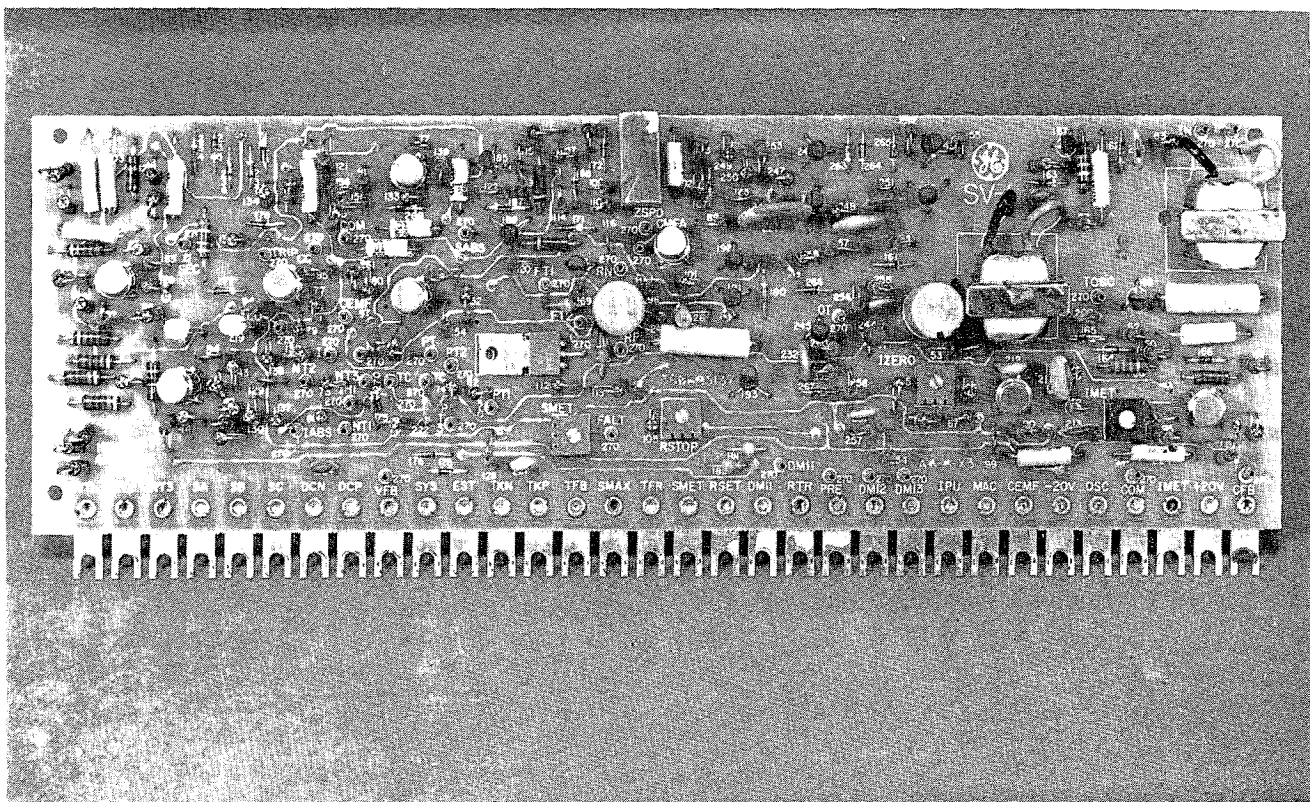

(Photo MG-5236-13)

Figure 6. Interface Card

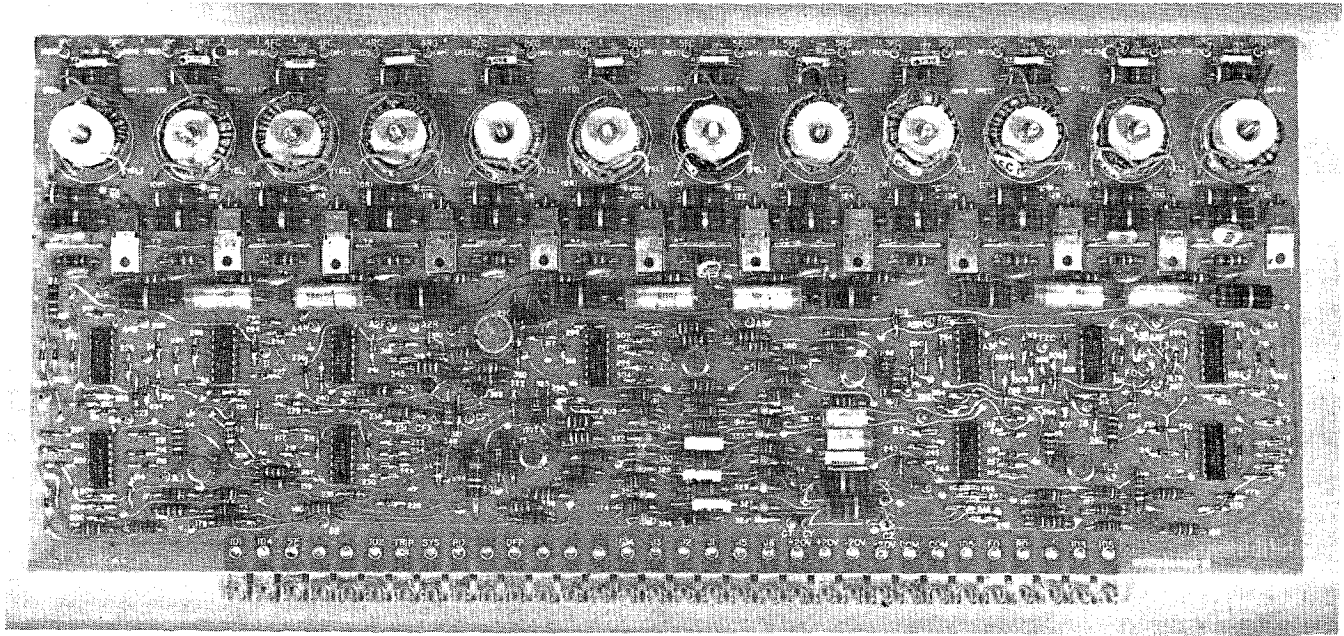

Figure 7. Auxiliary Control Card

(Photo MG-5374-2)

DIAGNOSTIC CARD (DGC) (OPTIONAL)

The diagnostic card performs no function under normal operating conditions but will program the drive into a diagnostic run mode and diagnostic static mode for ease in initial start up and troubleshooting.

MODIFICATION RACK (MDR) (OPTIONAL)

Any special features or functions which are related to the operation of the drive such as:

- Special reference
- Position orient
- Up to speed
- Independent timed acceleration and deceleration adjustments
- Etc.

are located in the modification rack located below the main control card.

CONTROL FUSES, MOV'S

The signal power for the control is taken from the three phase input through control fuses to the control voltage transformer (not shown on the block diagram). The control fuses are used to protect the control transformer and the metal oxide varistors (MOV) are used to protect the power unit from excessive transient over voltage conditions. Three (3) high resistance wires which provide line synchronization are connected to the load side of these fuses. The drive will not operate if any one of these fuses are open.

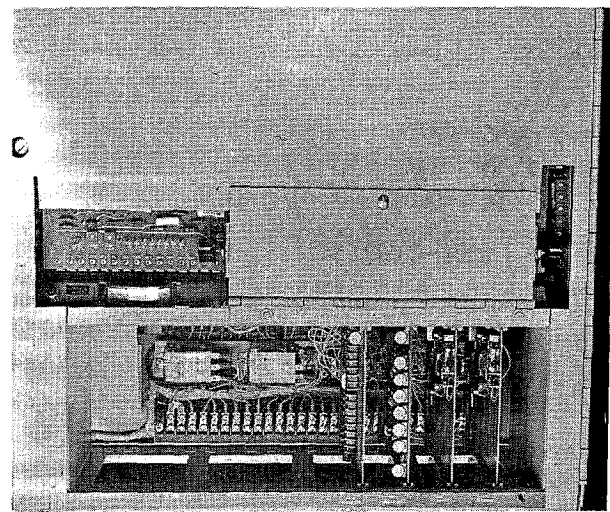

(Photo MG-5236-19)

Figure 8. Modification Rack

POWER CONNECTIONS

The power connections are the three phase input at L1, L2, L3 on the fuses; motor field F1 and F2 on the ATB terminal board and the DC power output DA1 and DA2.

SIGNAL CONNECTIONS

All signal connections are made on the 2TB, 3TB and 4TB terminal boards. Terminal boards 3TB and 4TB will

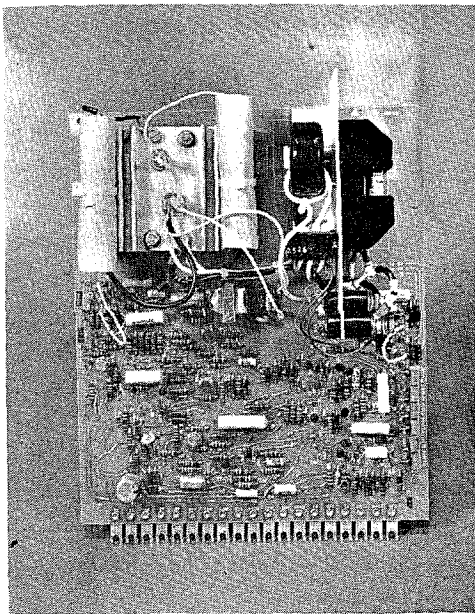

(Photo MG-5236-15)

Figure 9. Motor Field Control Card

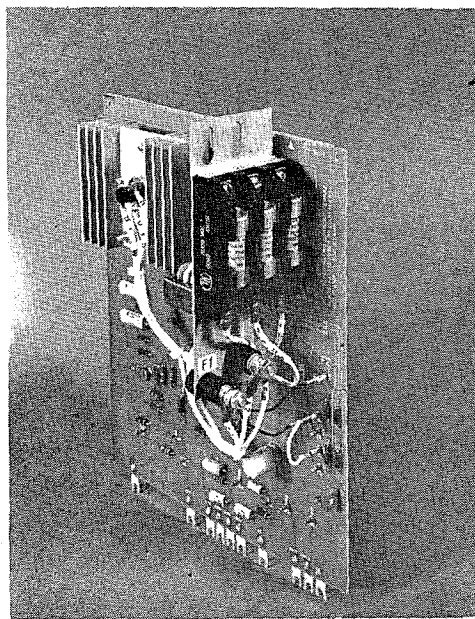

(Photo MG-5274-2)

Figure 10. Motor Field Exciter Card

be furnished only if required. Refer to system elementary diagram for complete description. The signals appearing on 2TB and their functions are described in Table III. Refer to the system elementary diagram for details.

START-UP

Every Valutrol DCSCR drive can be started up and made to run satisfactorily if the following step by step procedures are followed:

1. Verify that the terminal board screws are tight.
2. Verify that incoming power is the proper voltage and that the incoming wiring is complete and correct. Verify that the incoming reference voltages are correct.
3. With the diagnostic switch in its NORMAL position, close the circuit breaker and then apply power to the

drive. If the green "ready-to-run" light located on the lower left hand corner of the main control card is not illuminated, the most probably cause is incorrect incoming phase rotation. Remove power, reverse any two incoming leads and repeat.

4. Turn the local speed reference (LOC REF) potentiometer on the diagnostic card* to the center of its rotation and switch into the diagnostic run (DIAG RUN) position. As the local speed reference (LOC REF) potentiometer is rotated away from the control applying minus reference, the motor will begin to rotate. Check the tachometer polarity. With a DC tachometer, TKP is positive for rotation due to a minus reference. Switch back to the normal position. If motor rotation was incorrect, remove power and interchange the fields F1 and F2 at ATB.

* If a diagnostic panel was not supplied, see page 28, Figure 27.

POWER CONNECTIONS

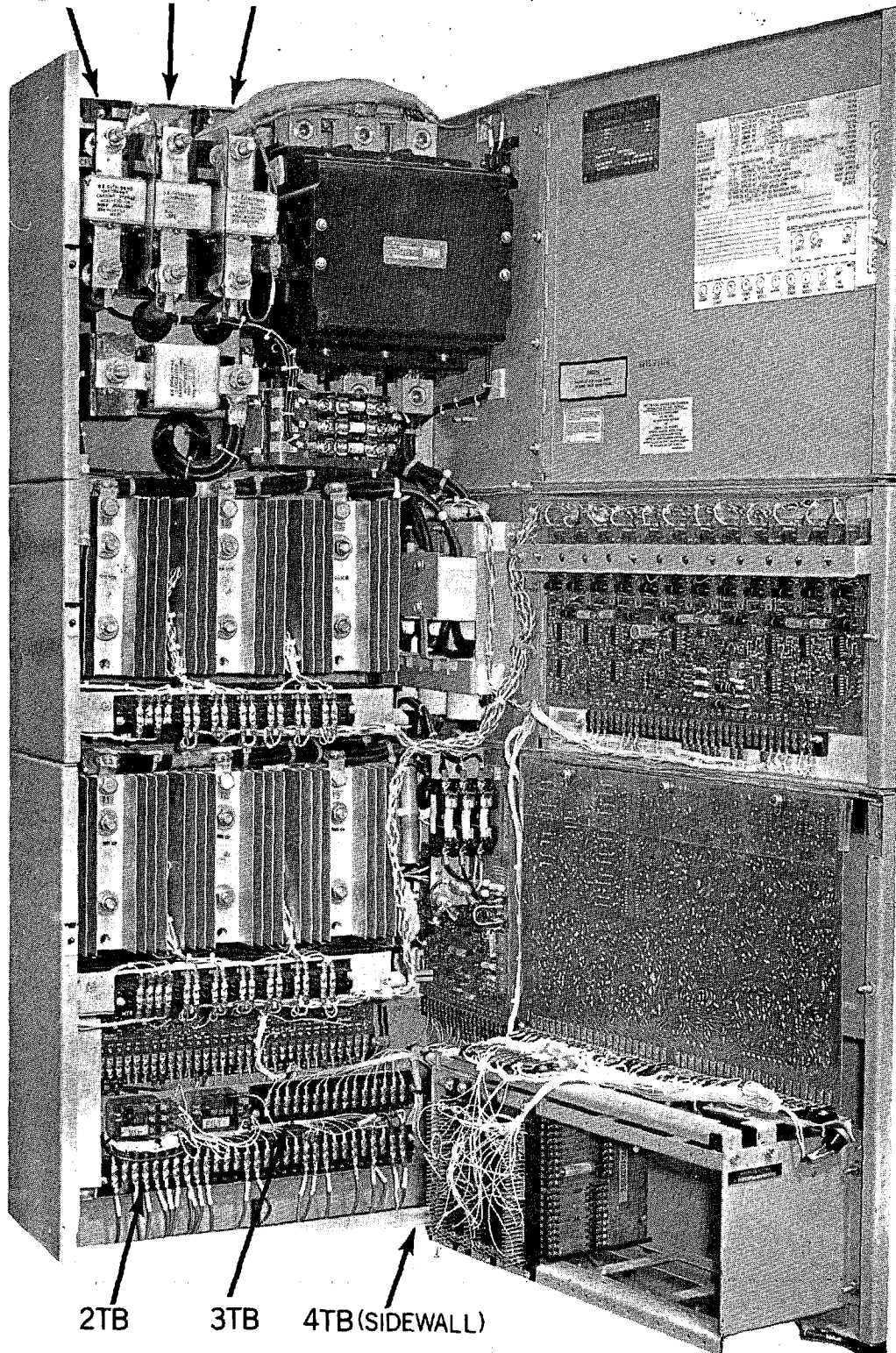

2TB 3TB 4TB (SIDEWALL)

SIGNAL CONNECTIONS

(Photo MG-5368-4)

Figure II Signal and Power Connections

TABLE III SIGNAL CONNECTIONS

2TB NO.	NOMENCLATURE	DESCRIPTION
1	-30 V	Unregulated negative dc voltage used as the return line for the CONTROL ON function and the static switches RUN and JOG., and possible modifications.
2	CONTROL ON	If CONTROL ON is not connected to -30V the drive will not start. If CONTROL ON is opened with the drive operating, the MA contactor will open and the drive will coast.
3, 4	FLT	A normally open, held closed relay contact. Under normal conditions this contact is closed. If a fault condition is detected, this contact opens.
5, 6, 7	MAX	A NO/NC relay contact which actuates when the MA contactor actuates.
8, 27	COM	Signal common. All signals are measured with respect to common, unless otherwise noted.
9	EST	External Fault Stop input. If EST is momentarily disconnected from common, the MA contactor will open and the motor will coast. The drive may not be restarted until the reset line is momentarily connected to COMMON (2TB-12). (see RSET below).
10, 11	FX1, X2	The internal 115V AC. FX1 is fused for external use.
12	RSET	Reset input. All fault shut downs inhibit the drive from starting until the fault has been cleared and the drive is reset. After the motor has come to a stop, the drive may be reset by momentarily connecting RSET to common. The drive will not restart until RSET is released from common. Momentarily connecting RSET to common or pushing the RESET BUTTON will initiate a coast stop shut-down.
13, 15 16, 17 18, 19 24, 25	SP1, SP2, ETC.	These are special purpose wires which are used to bring additional signals out of 2TB. Refer to the system elementary for details. Additional SP wires may be connected to 3TB and 4TB as required.
14	RUN	The drive will not start unless either RUN or JOG are connected to -30V, either at 2TB or by special purpose logic in the MDR. When RUN and JOG are released from -30V, the drive will decelerate to a stop and open the MA contactor.

TABLE III SIGNAL CONNECTIONS
(Continued)

2TB NO.	NOMENCLATURE	DESCRIPTION
20, 21	$\pm 20V$	Regulated power supply outputs.
22	IMET	Output to an optional Ima load instrument. The instrument is calibrated with the <u>IMET</u> potentiometer on the Interface Card.
23	SMET	Output to a Ima speed instrument. The instrument is calibrated with the <u>SMET</u> potentiometer on the Interface Card.
26	SMIN	Output from the <u>MIN SPEED</u> potentiometer on the main control card.
28	SR	Speed Reference input.
29, 30	TKP TKN	Input connections for motor mounted tachometer or machine mounted tachometer. NOTE: WITH A DC TACHOMETER, TKP MUST BE POSITIVE WHEN SYSTEM REFERENCE IS NEGATIVE AND DA1 IS POSITIVE WITH RESPECT TO DA2.

5. Switch the diagnostic switch to the normal position. Run the drive from the normal reference up to top speed. Adjust MAX SPEED, if required.
6. Close and secure the front door of the panel unit.

SEQUENCE OF OPERATION

POWER APPLIED

The control transformer (CPT) is energized through its primary fuses. The fans (if supplied) will come on.

The power supply card is energized and the dc output (± 20 volt) are applied through their fuses to the rest of the cards. All readings carry a tolerance of $\pm 10\%$.

The motor field supply is energized. Refer to the motor field supply instructions for details.

If no faults have been detected by the monitor section of the interface card, the fault relay FLT will close, and the "ready-to-run" indicator on the main control card will illuminate. Table IV tabulates the fault conditions which are monitored.

The oscillator will start, and the synchronizing signals SA, SB, SC will measure 8.5 volts RMS, ($\pm 10\%$). See Fig. 18 and 20.

START (CONNECT RUN (OR JOG) TO -30 VOLTS

SWITCH LOGIC

RUN or JOG will be switched from +30V to -30 volts. (under purchaser control).

The MA control line MAC from the main control card to the interface will be pulled down to -20 volts.

The interface card checks that no faults exist and that "control on" is connected to -30 volts before applying power to the coil of the MA pilot relay MAX.

MAX picks up, releasing the preconditioning signal PRE from common and applies power to the coil of the MA contactor.

When PRE is released from common, it switches to -4 volts which will release the main control card preconditioning after approximately 80 milliseconds.

Releasing preconditioning allows the drive to send firing pulses to the gates of the SCR's in the conversion module, and allows the normal signal flow to occur.

SIGNAL FLOW

If RUN is switched, the reference at SR is applied to the linear time section. The timed reference output TR will ramp to a voltage proportional to SR. The REF SCALE adjustment is used to set TR to 10.0 volts when the input

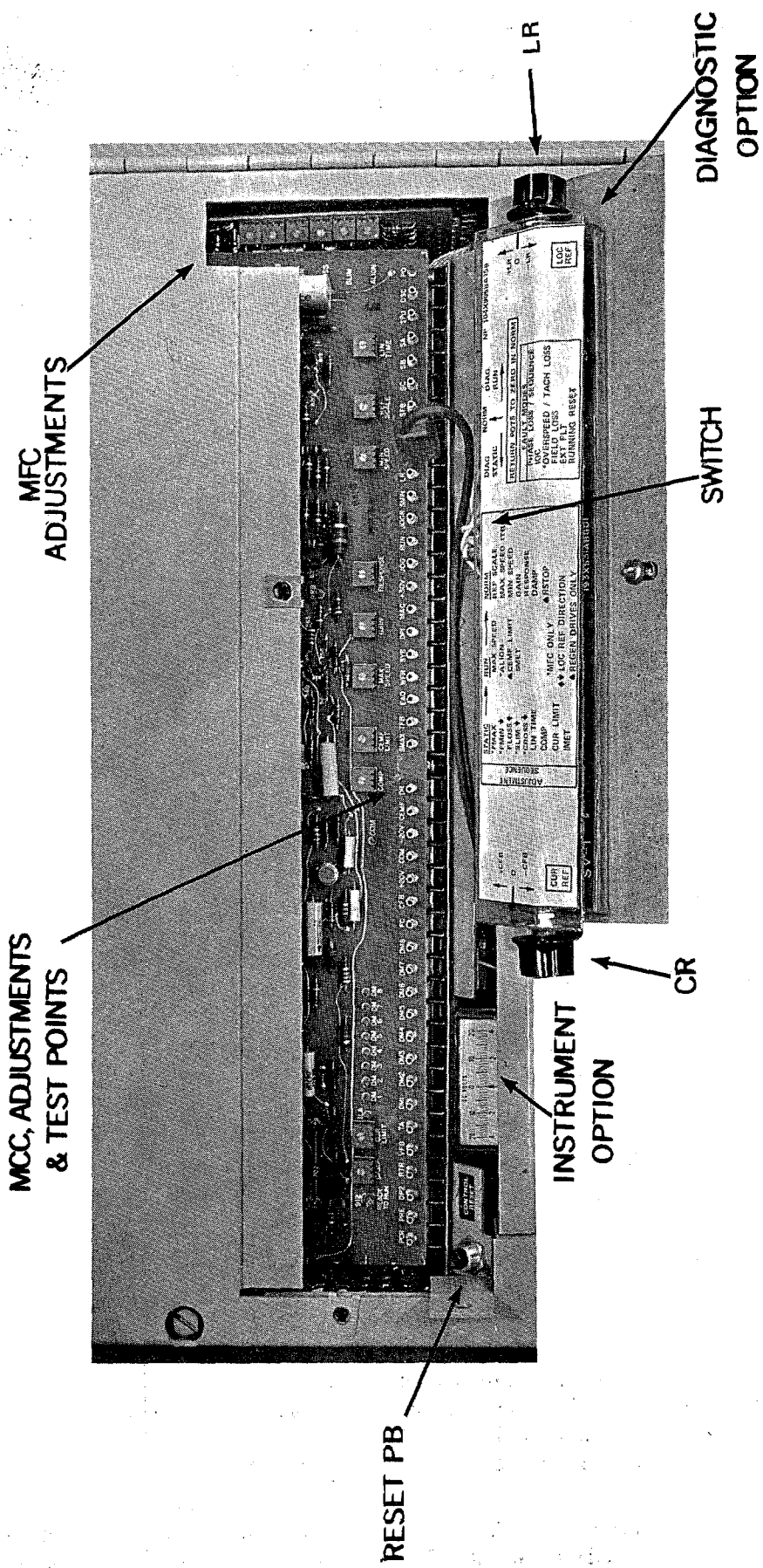

(Photo MG-5393)

Figure 12. Diagnostic Card and Lower Portion of Main Control Card

TABLE III SIGNAL CONNECTIONS
(Continued)

2TB NO.	NOMENCLATURE	DESCRIPTION
20, 21	$\pm 20V$	Regulated power supply outputs.
22	IMET	Output to an optional Ima load instrument. The instrument is calibrated with the <u>IMET</u> potentiometer on the Interface Card.
23	SMET	Output to a Ima speed instrument. The instrument is calibrated with the <u>SMET</u> potentiometer on the Interface Card.
26	SMIN	Output from the <u>MIN SPEED</u> potentiometer on the main control card.
28	SR	Speed Reference input.
29, 30	TKP TKN	Input connections for motor mounted tachometer or machine mounted tachometer. NOTE: WITH A DC TACHOMETER, TKP MUST BE POSITIVE WHEN SYSTEM REFERENCE IS NEGATIVE AND DA1 IS POSITIVE WITH RESPECT TO DA2.

5. Switch the diagnostic switch to the normal position. Run the drive from the normal reference up to top speed. Adjust MAX SPEED, if required.
6. Close and secure the front door of the panel unit.

SEQUENCE OF OPERATION

POWER APPLIED

The control transformer (CPT) is energized through its primary fuses. The fans (if supplied) will come on.

The power supply card is energized and the dc output (± 20 volt) are applied through their fuses to the rest of the cards. All readings carry a tolerance of $\pm 10\%$.

The motor field supply is energized. Refer to the motor field supply instructions for details.

If no faults have been detected by the monitor section of the interface card, the fault relay FLT will close, and the "ready-to-run" indicator on the main control card will illuminate. Table IV tabulates the fault conditions which are monitored.

The oscillator will start, and the synchronizing signals SA, SB, SC will measure 8.5 volts RMS, ($\pm 10\%$). See Fig. 18 and 20.

START (CONNECT RUN (OR JOG) TO -30 VOLTS

SWITCH LOGIC

RUN or JOG will be switched from +30V to -30 volts. (under purchaser control).

The MA control line MAC from the main control card to the interface will be pulled-down to -20 volts.

The interface card checks that no faults exist and that "control on" is connected to -30 volts before applying power to the coil of the MA pilot relay MAX.

MAX picks up, releasing the preconditioning signal PRE from common and applies power to the coil of the MA contactor.

When PRE is released from common, it switches to -4 volts which will release the main control card preconditioning after approximately 80 milliseconds.

Releasing preconditioning allows the drive to send firing pulses to the gates of the SCR's in the conversion module, and allows the normal signal flow to occur.

SIGNAL FLOW

If RUN is switched, the reference at SR is applied to the linear time section. The timed reference output TR will ramp to a voltage proportional to SR. The REF SCALE adjustment is used to set TR to 10.0 volts when the input

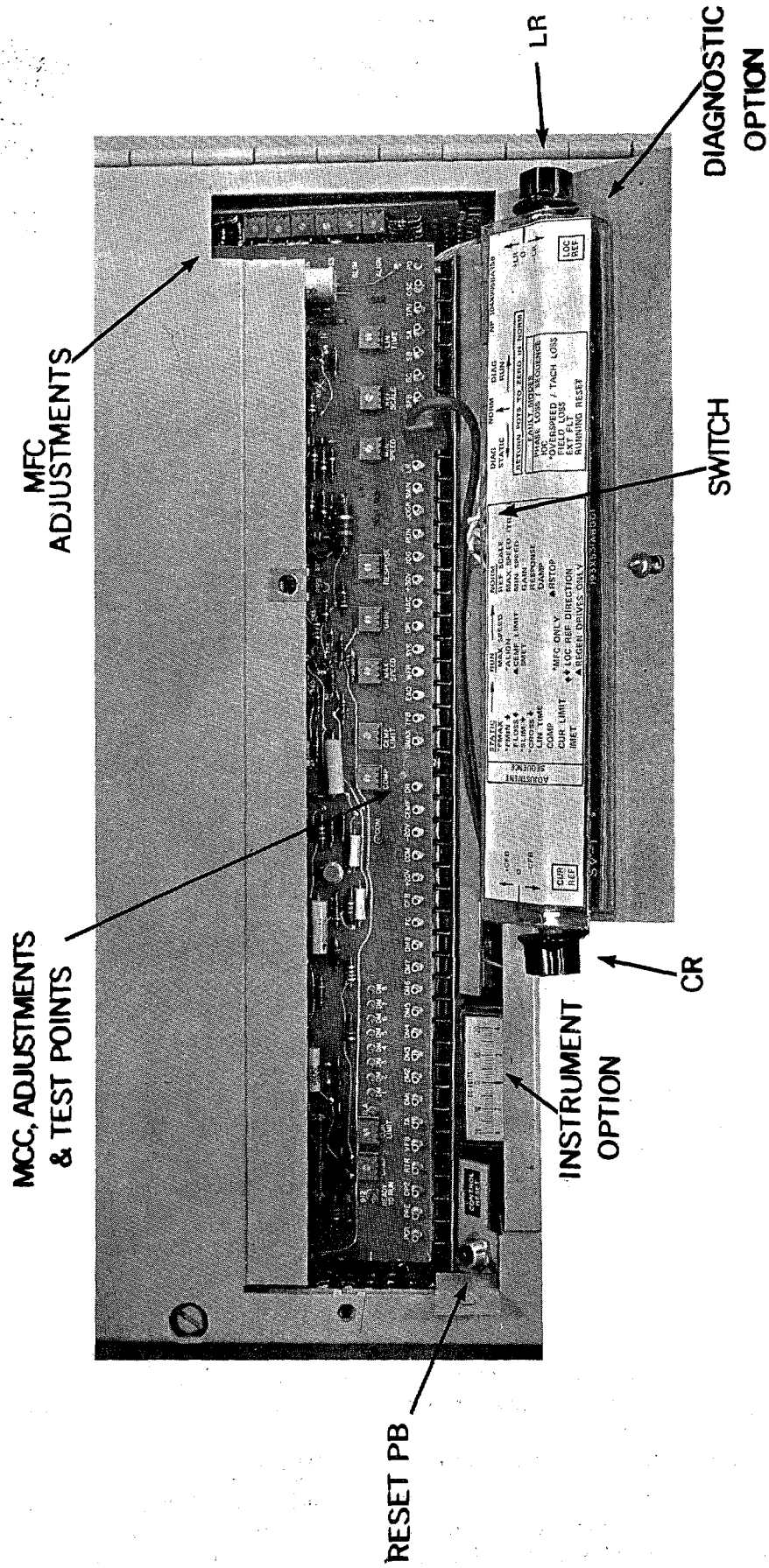

(Photo MG-5393)

Figure 12. Diagnostic Card and Lower Portion of Main Control Card

TABLE IV FAULT CONDITIONS

A fault has occurred if the fault relay contact (FLT) is open or if the READY TO RUN light is off. The conditions that can initiate a fault are as follows:

1. **No three phase power**
2. **Loss of an incoming phase**
3. **Incorrect phase rotation**
4. **AC power fuse blown**
5. **Control fuse is open**
6. **Power supply plus or minus DC fuse is open**
- ** 7. **Instantaneous overcurrent (IOC) level exceeded.**
8. **Motor thermo-switch (OLD) (If connected to fault circuitry).**
- * 9. **Timed over current (TOC) - electronic. (If connected to fault circuitry).**
- ** 10. **Loss of motor field**
11. **External Fault Stop momentarily released from Common.**
- * 12. **Other special functions to System Trip (SYS) or External Fault Stop inputs.**
13. **System Trip input (SYS) momentarily connected to + 10 volts.**
14. **RESET button depressed or RSET input momentarily connected to Common with motor rotating.**
15. **RESET button held depressed or RSET input held connected to Common.**
16. **Diagnostic mode selected with the motor rotating.**
17. **Oscillator failed "on".**
- * 18. **Tachometer fault (loss of tachometer signal)**
- ** 19. **Overspeed**
20. **Trip actuated from ACC (by AC overcurrent or SCR commutation failure).**
- * **May not be provided. Refer to instructions on Motor Field Supply and System elementary diagram.**
- ** **Can be caused by LOC REF and CUR REF settings in Static Diagnostic mode.**

After the fault condition has been cleared and the motor has come to standstill, the drive can be RESET by any of the following three methods:

1. **Momentarily remove the three phase power and re-apply.**
- # 2. **Push the RESET button**
- # 3. **Momentarily connect RSET to common.**
- # **If all fault conditions have been cleared but the drive fails to RESET, the RSTOP adjustment may be set too low.**

WAVEFORMS

All illustrations were photographed in the forward motoring quadrant with zero volts on center line at 2 msec per division.

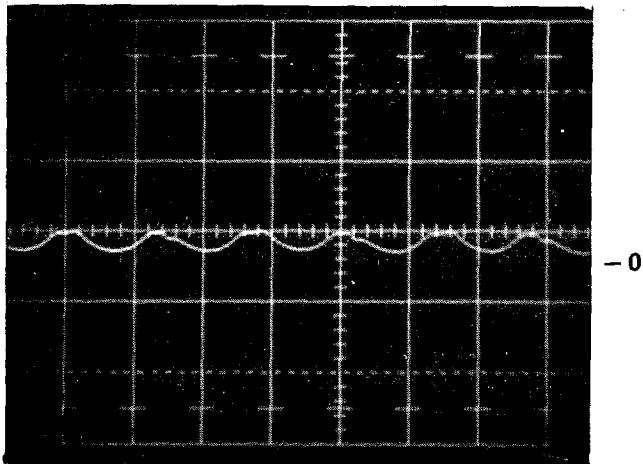

2 msec / div

At low current level 1 volt / division

Figure 14. Current Feedback (CFB)

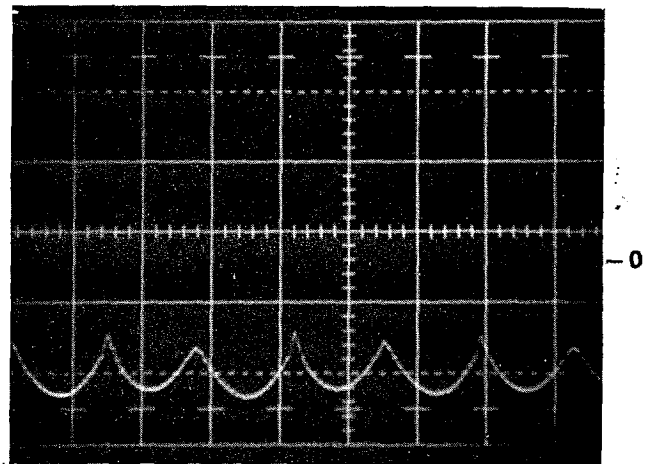

2 msec / div

At Continuous current 1 volt / division

Figure 15. Current Feedback (CFB)

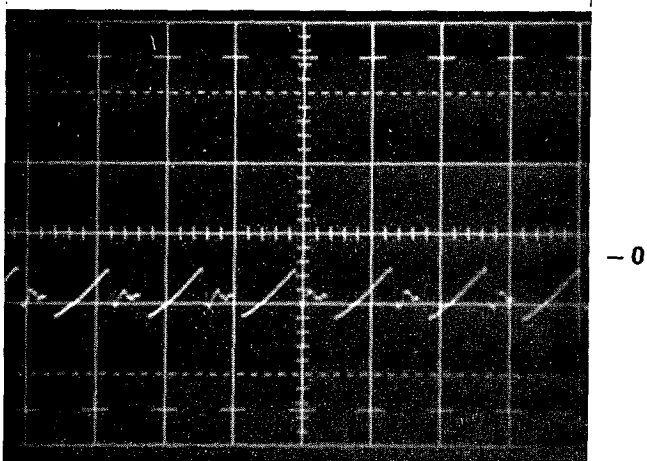

2 msec / div

At low current and 200 volts 5 volts/division

Figure 16. Voltage Feedback (VFB)

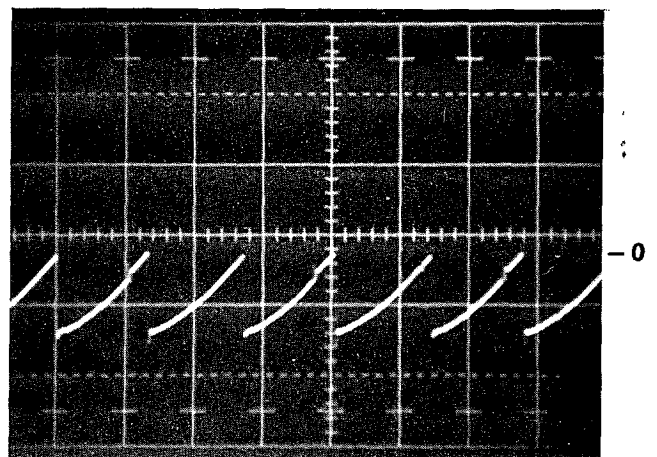

2 msec / div

At continuous current and 200 volts 5 volts/division

Figure 17. Voltage Feedback (VFB)

WAVEFORMS

All illustrations were photographed in the forward motoring quadrant with zero volts on center line at 2 msec per division.

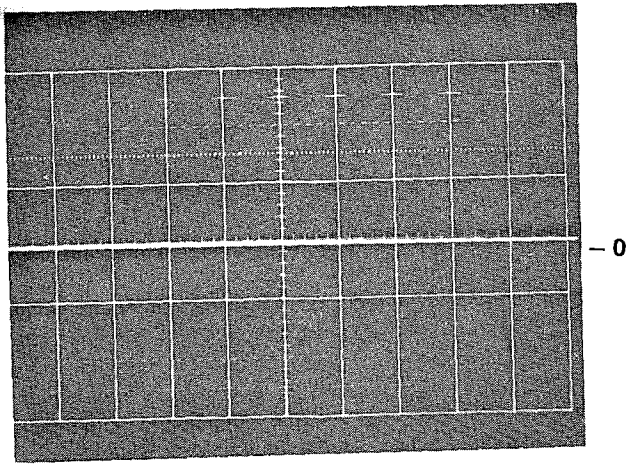

2 msec / div
10 volts / division

Figure 18. Oscillator (OSC)

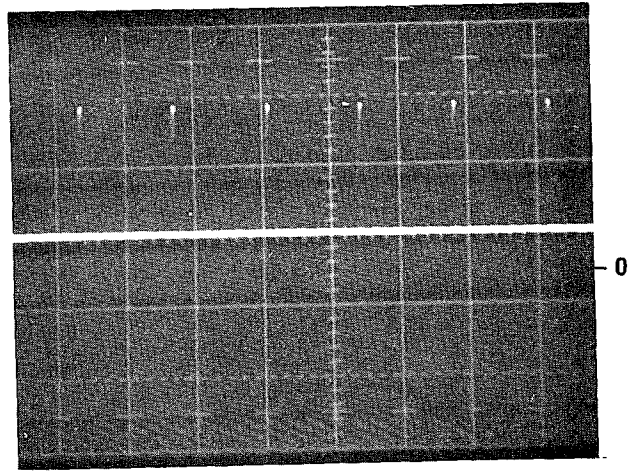

2 msec / div
2 volts / division

Figure 19. Initial Pulse (IPU)

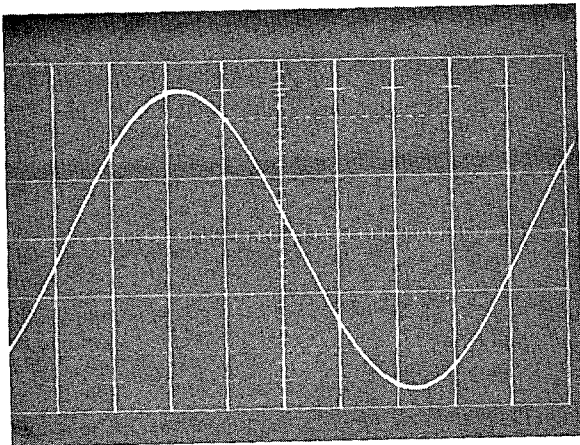

2 msec / div
Typical of SA, SB & SC
SB lags SA by 120°
SC lags SB by 120°
5 volts / division

Figure 20. Synchronizing Signal (SA)

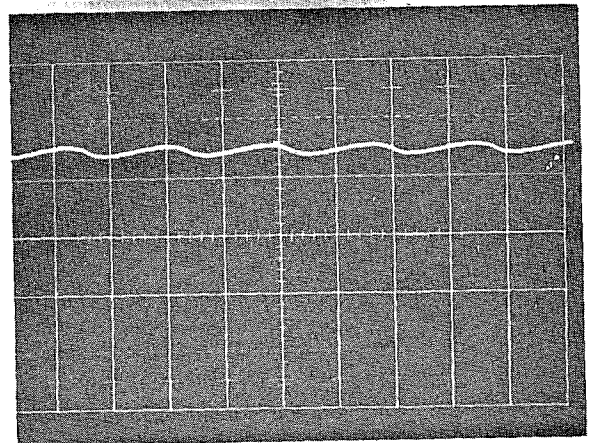

2 msec / div
With an AC tachometer at 450 RPM
1 volt / division

Figure 21. Speed Feedback (SFB)

WAVEFORMS

All illustrations were photographed in the forward motoring quadrant with zero volts on center line at 2 msec per division.

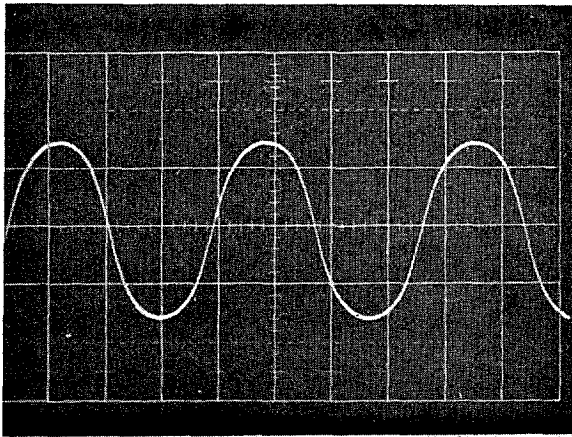

2 msec / div

With an AC Tachometer at 450 RPM
1 volt / division

Figure 22. Tachometer Feedback (TFB)

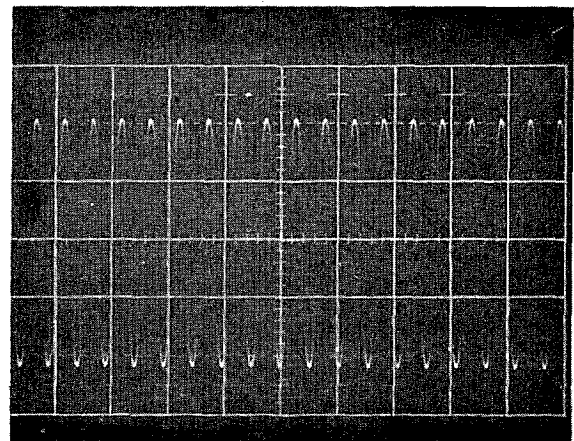

2 msec / div

With an AC Tachometer at 3160 RPM
5 volts / division

Figure 23. Tachometer Feedback (TFB)

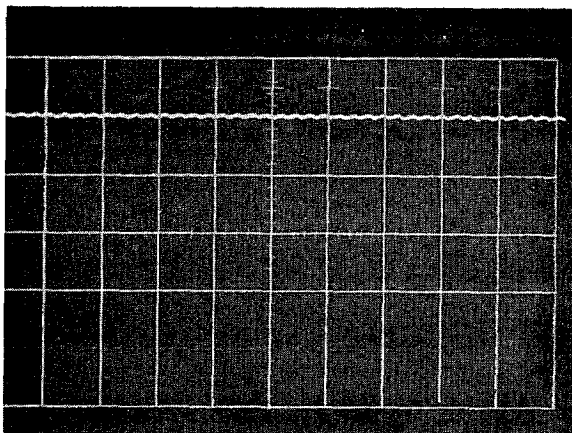

2 msec / div

With an AC Tachometer at 3160 RPM
5 volts / division

Figure 24. Speed Feedback (SFB)

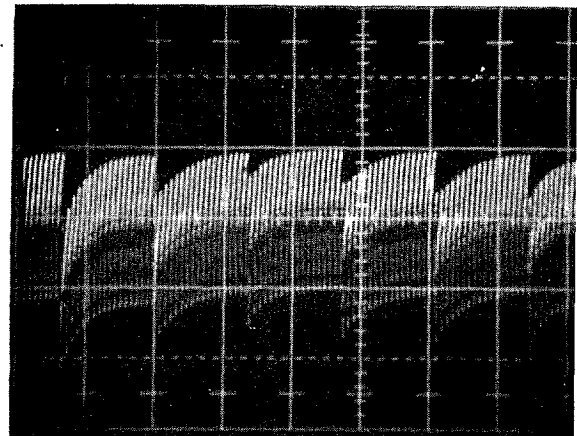

2 msec / div

AC Coupled

0.1 volt/division

Figure 25. Pulse Output (PO)

WAVEFORMS

All illustrations were photographed while motoring with negative system reference with zero volts on center line at 2 msec per division unless otherwise noted.

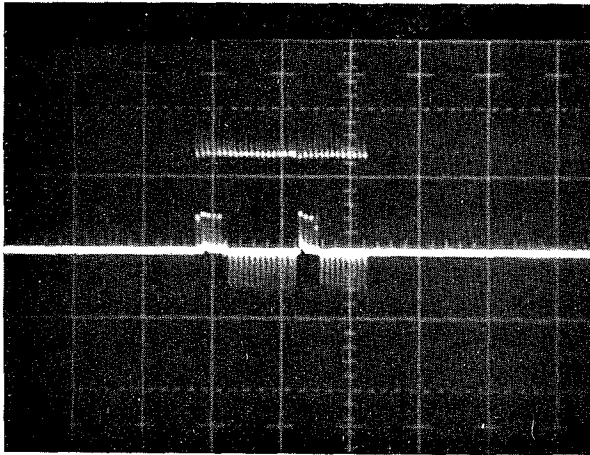

2 msec / div

Gate to Cathode Firing Signal 1G-1C
Typical of all six Signals
1 volt / division

Figure 26. Gate to Cathode Firing Signal

at SR is set for top speed. The time for TR to ramp from 0 to 10 volts is adjustable from .3 to 60 seconds with the LIN TIME adjustment. See jumper table on system elementary. (Ranges: .3 to 10 sec. or 2 to 60 sec.).

The speed (or CEMF) feedback from the motor tachometer is scaled with a selectable resistor network on the interface card, and rectified (if required) on the main control card. The output of the speed feedback section is SFB, and will be 10 volts at top speed. MAX SPEED is adjusted to make the actual top speed correspond to desired top speed. See figures 21 and 24.

The timed reference TR, the JOG reference JOGR, and the speed feedback SFB are summed by the regulator error amplifier. The error amplifier output EAO will be a low voltage (nearly zero) when the drive is regulating speed. EAO will not be low when the drive is in current limit or CEMF limit. The gain of the error amplifier is set with the GAIN adjustment. The GAIN adjustment is used primarily to improve the response of the drive in the constant horsepower region when the motor field supply is a motor field control MFC.

To maintain good load regulation, the error amplifier is fed into the regulator integrator. The output of the integrator is the reference, DR, to the driver. The response of the control below base speed is set with the RESPONSE adjustment.

There is a limit however, to how responsive a drive may be set. Stability of the drive is decreased as its response is increased. If motor field supply is the motor field control (MFC), the RESPONSE adjustment is desensitized when the drive is operating in the constant horsepower region of the torque speed curve.

To protect the system, three limit sections are provided; counter-EMF (CEMF) limit and two current limits. The output of the CEMF limit and the primary current limit drive the regulator integrator and will override the error amplifier, if required. The primary current limit is set with the CUR LIMIT adjustment and the counter EMF limit with the CEMF LIMIT adjustment. Typically the primary or regulator current limit is set at 150% of the motor nameplate current of 3.75 volts ($\pm 10\%$) of current feedback, CFB. The counter EMF is normally limited to 250 armature volts at no load, or 5.75 volts ($\pm 10\%$) of CEMF for drives rated 240 volts DC. For drives rated 500 volts DC the CEMF limit is normally 510 volts at no load or 5.60 volts ($\pm 10\%$) at CEMF. The secondary or driver current limit is in the driver section and will be described below. The primary current limit, if used, should not be set higher than the driver current limit. The driver current limit may be inhibited or adjusted as described below.

The main purpose of the secondary, or driver, current limit is to be an operating current limit if the regulator, or primary current limit, is not used and the system is controlled by other signals summed at the driver junction. The driver current limit may be increased by connecting a jumper from DCX to DCY on the main control card which will increase the limit from approximately 130% to 175% of the motor nameplate current. Alternative levels may be established by connecting a resistor between DCL and DCX on the main control card. For normal levels of regulating current limit, either DCX should be jumpered on DCY to increase the driver current limit or it should be inhibited by connecting DCI to COM. For regulating current limit above 150%, a resistor should be connected between DCL and DCX to raise the driver limit above 175% or it should be inhibited with a jumper between DCI and COM.

The counter-EMF signal CEMF is developed on the main control card by subtracting a signal proportional to the IR drop of the motor from voltage feedback. This is set with the COMP adjustment.

The driver reference, DR, the voltage feedback, VFB, an armature current signal from damping adjustment DAMP, and the driver current limit output are summed at the input to the driver. The driver converts this error to pulse trains which drive the SCR gates in such a manner as to maintain the motor voltage proportional to the driver reference. The damping adjustment DAMP controls the response of the driver.

Generally speaking, DAMP is used only to quiet small oscillations which occur in the current under light load conditions. Too much damping will slow down the system and response and tend to cause over shoot.

The driver provides a signal IPU to the oscillator on the interface card to generate an initial pulse at the exact point in time that an SCR is to be fired. See Fig. 19.

Two driver monitor points are available, PCR and PO. PCR is the phase control reference which causes the output pulse trains to phase shift in time with respect to the ac line. As PCR moves from zero to +6 volts ($\pm 10\%$), the output pulses will shift from full off to full on. PO is used to monitor the pulse outputs to the SCR's. See Fig. 25 and 26.

STOP

There are two stop sequences, normal stop and fault stop. With a normal stop the drive regenerates to near zero speed before opening the MA contactor. A fault stop opens the contactor and drive coasts to a stop.

Normal stop (disconnect RUN from -30 volts).

RUN will switch from -30 volts to +30 volts. MAC will switch to zero volts and the system reference input to the linear time section will be shunted to common.

The timed reference TR will begin to time down to zero and the drive speed will come down accordingly.

The regenerative stop circuit on the interface card will hold the contactor closed until the CEMF signal is almost zero, corresponding to zero speed. At this time, the preconditioning signal PRE goes to common, removing power from the MAX coil. 100 milliseconds later, MAX drops out removing power from MA, which then drops out. The CEMF level corresponding to zero speed is set by the RSTOP adjustment. If RSTOP is set too far (CW) power is removed prematurely and the drive will coast into zero speed. If RSTOP is set too far (CCW) the contactor will not open at all.

In some cases the regenerative stop circuit, (described above) may be under the control of the speed feedback signal, SFB, rather than the CEMF signal.

FAULT STOP - Fault detected (See Table IV) or CONTROL ON is open.

The preconditioning signal PRE is immediately applied to the main control card, forcing the drive into zero current or coast conditions. As soon as the current goes to zero, preconditioning is established throughout the card.

The MA contactor unconditionally drops out 100 milliseconds after the fault condition occurs.

The drive can not be restarted until the motor has come to rest. If the STOP was initiated by a fault, this is taken care of automatically, but it is the purchaser's responsibility to not reclose "CONTROL ON" before the motor has come to rest. After the motor has stopped, push the RESET button.

DIAGNOSTIC STATIC (SWITCH TO LEFT)

LOGIC

The RUN and JOG inputs are inhibited. This prevents the references SR and JOGR from activating the drive and holds the MA contactor open.

The current reference potentiometer CUR REF controls the current feedback signal CFB.

The local reference LOC REF potentiometer is connected into the input of the linear time section and into the speed feedback section. The local reference is also connected to the field diagnostic reference FDR. Refer to motor field control instructions (GEK-24971) for details of operation.

To simplify signal tracing, the gain of the regulator and drive is reduced and the speed feedback signal to the regulator error amplifier is removed.

SIGNAL FLOW

The local reference LR is applied directly to the input of the linear time section, by-passing the REF SCALE adjustment. The timed output TR will ramp to a voltage equal to LR in magnitude and polarity in a time determined by the setting of LIN TIME.

The local reference LR is also applied to the input of the last stage of the speed feedback section. The output SFB will be equal to LR in magnitude, but opposite in polarity. The tachometer scaling circuit and its output TFB are unaffected by the local reference and will remain at zero. As the signal from SFB into the regulator error amplifier is inhibited the primary purpose of exercising SEB is to check those special function circuits in the modification rack which are programmed from SFB, and/or SFB functions of a MFC.

A dummy feedback signal to replace the normal SFB signal is connected from the output of the regulator integrator output DR to the input of the regulator error amplifier. Under these conditions DR is equal to the magnitude of TR but opposite in polarity as long as the current reference is below the current limit setting. As the current reference is raised, the current feedback signal CFB will exceed the current limit level set by CUR LIM and force the DR output into negative saturation for forward current limit and positive saturation for reverse current limit. See Fig. 14 and 15.

Current feedback will also program the CEMF output to a level proportional to the CFB level and the COMP adjustment.

The load instrument output IMET will also respond to the current reference.

The gain of the drive is reduced so that the phase control reference PCR is equal to the magnitude of the driver reference DR as long as the current reference is set to zero.

With an oscilloscope, the initial pulse output IPU, and the pulse output PO may be monitored to verify proper operation. See Fig. 19.

DIAGNOSTIC RUN (SWITCH RIGHT)

In diagnostic run, the local reference LR and the diagnostic switch are substituted for the reference(s) SR, JOGR and the RUN and JOG switch inputs just as in diagnostic static. The drive then runs normally with one important exception: system feedback is normal but the signal from system feedback to the regulator error amplifier is inhibited and the dummy feedback from DR is still in place.

The net effect is the drive operates as a base speed voltage regulated from the LOC REF potentiometer.

CALIBRATION PROCEDURE

The diagnostic card is used to generate the appropriate test signals and operating modes to calibrate the drive. If a diagnostic card has not been furnished, one may be ordered or the test circuit shown in Figure 28 may be used.

Make all connections prior to applying input power. To exit from the DIAGNOSTIC RUN mode, push the RESET button to initiate a fault shutdown, then remove input power.

***All connections may be made to the test pots on the front of the main control card except for CRM and FDR which are located on the RTB terminal board.**

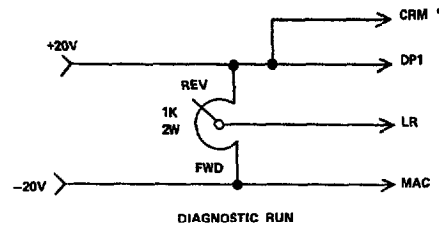
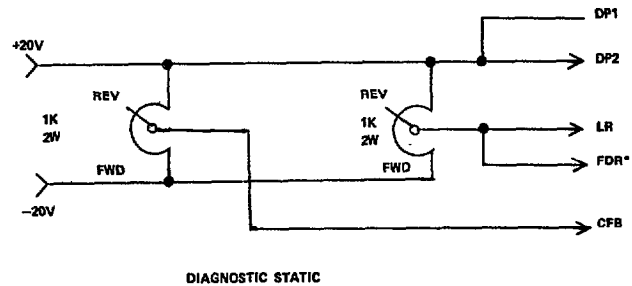

Figure 27. Diagnostic Test Circuits

To avoid confusion and possible interaction, the adjustments should be made in the following sequence. Two sequences are listed, one when a motor field exciter MFE is provided, and one when a motor field control MFC is provided. Refer to the system elementary to determine which has been furnished.

TABLE II
Recalibrating Adjustment Sequences

	WITH MOTOR FIELD CONTROL	WITH MOTOR FIELD EXCITER
DIAGNOSTIC STATIC MODE, ADJUST	<u>LINE</u> <u>FMAX</u> <u>FMIN*</u> <u>FLOSS</u> <u>SLIM</u> <u>CROSS*</u> <u>LIN TIME</u> <u>COMP</u> <u>CUR LIMIT</u> <u>IMET (IF USED)</u>	<u>LINE</u> <u>FLOSS</u> <u>LIN TIME</u> <u>COMP</u> <u>CUR LIMIT</u> <u>IMET (IF USED)</u>
DIAGNOSTIC RUN MODE, ADJUST	<u>MAX SPEED</u> <u>ALIGN</u> <u>CEMF LIMIT</u> <u>SMET (IF USED)</u>	<u>MAX SPEED</u> <u>CEMF LIMIT</u> <u>SMET (IF USED)</u>
NORMAL MODE, ADJUST	<u>REF SCALE</u> <u>MAX SPEED (TRIM)</u> <u>MIN SPEED (IF USED)</u> <u>GAIN</u> <u>RESPONSE</u> <u>DAMP</u> <u>RSTOP</u>	<u>REF SCALE</u> <u>MAX SPEED (TRIM)</u> <u>MIN SPEED (IF USED)</u> <u>GAIN</u> <u>RESPONSE</u> <u>DAMP</u> <u>RSTOP</u>

All of the high voltage inputs to the controller have been scaled down with the scale factors shown on the test data sheet.

For example: On a 240V motor voltage feedback VFB will be 5 volts when the armature voltage is 216 volts. If VFB is 3.2 volts, then the armature voltage is $3.2 \times 216/5 = 138$ volts. If armature voltage is 67 volts, VFB will be $67 \times 5/216 = 1.55$ volts. All values have a tolerance of $\pm 10\%$.

CALIBRATION WITH MOTOR FIELD CONTROL (MFC)

All readings can have a tolerance of $\pm 10\%$.

Select Diagnostic static and set the CUR REF and LOC REF to the center positions.

LINE (Line Impedance Compensation)

This function is factory set at approximately mid-range (3½% impedance). CW rotation of LINE pot adjusts for greater line impedance. Range is 2% to 5% with no jumper RLA to PCR. Range is 4% to 10% with jumper RLA to PCR. If impedance is unknown a mid-range setting, no jumper, is suggested.

FMAX (maximum field)

Set the LOC REF potentiometer for -1 volt at LR. Adjust FMAX until FC corresponds to the maximum field FC on the test data sheet.

FMIN (minimum field - limit)

Set LOC REF potentiometer for -7 volts at LR. Adjust FMIN until FC corresponds to minimum field FC on the test data sheet.

FLOSS (field loss - fault)

Set the LOC REF to center position and reset the drive. Adjust FLOSS full CCW.

Monitor FC and move the LOC REF potentiometer Rev until FC corresponds to the field loss value on the test data sheet. Slowly rotate FLOSS CW until the "Ready to Run" light turns off indicating a drive fault. Reset the drive.

SLIM (Speed limit - overspeed fault)

Set the LOC REF to center position and reset the drive. Adjust SLIM full CW.

Monitor SFB and move the LOC REF potentiometer Fwd until SFB corresponds to the overspeed limit on the test data sheet. Slowly adjust SLIM CCW until the "Ready to Run" light turns off indicating a drive fault.

CROSS (cross over - field)

Set CROSS full CCW. Turn the LOC REF potentiometer Fwd until LR corresponds to the cross over LR on the test data sheet.

Monitor FC and adjust CROSS CW until FC just starts to increase. CROSS may be checked when the drive is running in normal operation by verifying that CEMF reads the value on the test data sheet with the drive operating above based speed.

LIN TIME (linear time)

Monitor TR and set to zero with the LOC REF potentiometer. Rapidly turn the LOC REF full Fwd and measure the time for TR to ramp to 10 volts ($\pm 10\%$). Adjust LIN TIME until this time corresponds to the test data sheet linear time.

COMP (compensation – IR)

Set the LOC REF potentiometer to center position. Adjust the CUR REF potentiometer Fwd or Rev until CFB is at 5 volts ($\pm 10\%$).

Monitor CEMF and adjust COMP until CEMF equals the value on the test data sheet.

CUR LIMIT (current limit)

Set CUR LIMIT full CW. Adjust the CUR REF potentiometer until CFB corresponds to the current limit level on the test data sheet. Monitor DR and turn CUR LIMIT CCW until DR just moves away from zero.

IMET (load instrument calibration)

Adjust the CUR REF until CFB corresponds to full load current. Verify that the optional load instrument reads full load. If not, remove power; adjust IMET and repeat.

Set the LOC REF to the center position; reset the drive and switch to Diagnostic Run.

CEMF LIMIT (counter emf limit)

Turn CEMF LIMIT full CCW and turn the LOC REF potentiometer full Fwd. Adjust CEMF LIMIT until CEMF corresponds to the CEMF LIMIT on the test data sheet.

MAX SPEED/ALIGN (max speed/tachometer loss align-fault).

Turn MAX SPEED full CCW. Turn ALIGN full CW. Adjust the LOC REF potentiometer until CEMF reads 5 volts ($\pm 10\%$). Adjust MAX SPEED until SFB corresponds to the base speed feedback on the test data sheet.

Monitor TA and adjust ALIGN CCW until TA is approximately zero volts.

SMET (Speed instrument calibration)

Turn the LOC REF potentiometer until SFB is 3 volts ($\pm 10\%$). The optional speed indicator should indicate 30% top speed. If it does not, push the RESET button to initiate a shut down. Remove power, adjust SMET and repeat.

Return the Diagnostic switch to Normal.

REF SCALE/MAX SPEED (reference scale/max speed)

Turn REF SCALE full CCW. Start the drive and apply top speed reference to SR. Adjust the REF SCALE potentiometer until SFB is 10 volts ($\pm 10\%$). This normalizes the timed reference TR and speed feedback, SFB for 10 volts ($\pm 10\%$) at top speed.

Now measure motor RPM and adjust MAX SPEED (if necessary) until the actual RPM corresponds to the desired top speed. If actual top RPM was off by more than 5% reset ALIGN as detailed above.

RSTOP (Regenerative stop)

With the motor operating at some RPM, call for a drive stop by initiating the proper magnetics which will release 2TB-14 from -30 volts. The motor will decelerate to a low speed and the MA contactor will open. If the MA contactor opens before the drive comes down to a stop, RSTOP is set too high. If the MA contactor fails to open, RSTOP is set too low. Push the RESET button to drop out MA prior to removing power. RSTOP should be readjusted with power removed. Turn RSTOP CW to drop out MA at a higher speed.

MIN SPEED (minimum speed)

Reduce the system reference to minimum and start the drive. Adjust MIN SPEED, as required, to meet system minimum speed requirements. Refer to system elementary for circuit details.

GAIN, RESPONSE, DAMP and COMP (Stability adjustments).

1. Set DAMP potentiometer at minimum 7 o'clock position.
2. Place the Diagnostic switch in the static mode. Adjust CUR REF for 2.5 volts at test pin CFB. This is equivalent to rated armature current.
3. Set COMP potentiometer by reading at the CEMF pin a value equal to 0.0312 (240V – motor CEMF). For a 240V .0148 (500V – motor CEMF).

Typical values of motor counter EMF.

MOTOR HORSEPOWER	MOTOR COUNTER EMF	
	240V	500V
5 to 15	215	455
20 to 40	225	470
50 to 125	230	480
150 to 250	—	490

The reading at CEMF test pin is a voltage proportional to motor CEMF

Example: 20 to 40 HP @ 240V

$$\begin{aligned} \text{CEMF} &= 0.0312 (240 - 225) \\ &= 0.468 \text{ volts} \end{aligned}$$

The COMP potentiometer is now set for proper operation. Regardless of overload range, IOC setting or motor field range this setting is correct and should not be changed.

4. Set the GAIN adjustment by calculating the GAIN number and referring to the chart. (Fig. 28)

$$\text{Gain No} = \frac{\text{Maximum Operating Speed}}{\text{Motor Base Speed}}$$

See motor nameplate under - Speed

Motor Base Speed/Maximum Operating Speed

Example: 1150/3600 RPM

5. Set LIN TIME potentiometer at minimum (7 o'clock)
6. Set RESPONSE potentiometer at minimum (7 o'clock)

When the drive is functioning properly in all other respects make small incremental step increases and decreases in speed below base speed. Observe armature current for bumping repeatedly before steady state speed is attained.

Increase the RESPONSE setting (move CW) until bumpy setting current is observed. Then reduce the RESPONSE setting until no bumps (or only one) is observed. This is the maximum RESPONSE setting.

In general, settings below 10 o'clock will show signs of increasing sluggishness. Settings greater than 2 o'clock may show signs of hard or even continuous bumping. Full RESPONSE setting (5 o'clock) will usually trip the IOC

7. RESET LIN TIME to required setting.

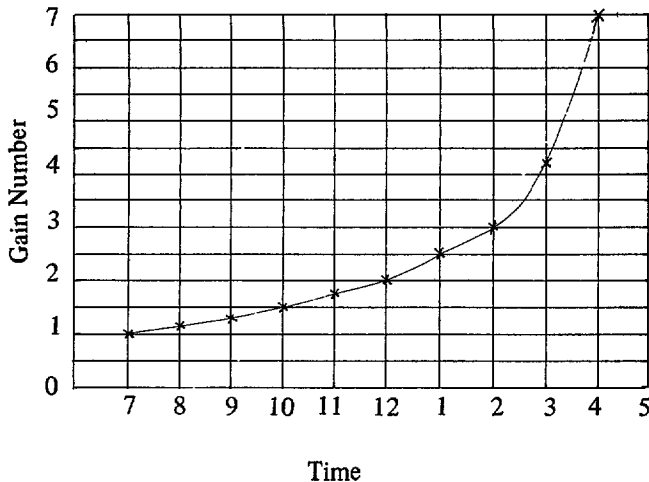

Gain Pot Setting

After this setting has been made, make no further adjustments to the Gain Pot.

Figure 28 Gain Adjustment

CALIBRATION WITH MOTOR FIELD EXCITER (MFE)

Refer to motor field exciter instructions GEK-24972 for details of operation.

Select Diagnostic Static and set CUR REF and LOC REF to the center positions.

LINE (Line Impedance Compensation)

This function is factory set at approximately mid-range (3½% impedance). CW rotation of LINE pot adjusts for greater line impedance. Range is 2% to 5% with no jumper RLA to PCR. Range is 4% to 10% with jumper RLA to PCR. If impedance is unknown a mid-range setting, no jumper, is suggested.

FLOSS (field loss - fault)

Adjust FLOSS full CCW and reset

Monitor FC and move the LOC REF Rev until FC corresponds to the field loss value on the test data sheet. Slowly adjust FLOSS CW until the "Ready to Run" light turns off indicating a drive fault. Reset the drive.

COMP (compensation - IR)

Adjust the LOC REF potentiometer to the center position. Adjust the CUR REF potentiometer Fwd or Rev until CFB is at 5 volts (±10%).

Monitor CEMF and adjust COMP until CEMF equals the value on the test data sheet.

CUR LIMIT (current limit)

Adjust CUR LIMIT full CW. Turn the CUR REF potentiometer until CFB corresponds to the current limit value on the test data sheet.

Monitor DR and turn CUR LIMIT CCW until DR just moves away from zero.

IMET (load instrument calibration)

Turn the CUR REF until CFB corresponds to full load current. Verify that the optional load instrument reads full load. If not, remove power, adjust IMET and repeat.

LIN TIME (linear time)

Monitor TR and set to zero with the LOC REF. Rapidly turn the LOC REF full Fwd and measure the time for TR to ramp to 10 volts (±10%). Adjust LIN TIME until this time corresponds to the test data sheet linear time.

Set the LOC REF to the center position and switch to Diagnostic Run.

MAX SPEED (maximum speed)

Adjust the LOC REF until the motor is running at actual top speed. Adjust MAX SPEED Until SFB is 10 volts (±10%).

CEMF LIMIT (counter emf limit)

Turn CEMF LIMIT full CCW and turn the LOC REF full Fwd. Adjust CEMF LIMIT until CEMF corresponds to the CEMF LIMIT on the test data sheet.

SMET (speed instrument calibration)

Turn the LOC REF potentiometer until SFB is 3 volts (±10%). The optional speed indicator should indicate 30% top speed. If it does not, push the RESET button to initiate a shut down. Remove power, adjust SMET and repeat.

Return the Diagnostic switch to Normal.

REF SCALE (reference scale)

Turn REF SCALE full CCW. Start the drive and apply top speed reference to SR. Adjust the REF SCALE potentiometer until SFB is 10 volts ($\pm 10\%$). This normalizes the timed reference TR and speed feedback, SFB for 10 volts ($\pm 10\%$) at top speed.

MIN SPEED (minimum speed)

Reduce the system reference to minimum and start the drive. Adjust MIN SPEED as required to meet system minimum speed requirements. Refer to system elementary diagram for circuit details.

RSTOP (regenerative stop)

With the motor operating at some RPM, call for a drive stop by initiating the proper magnetics which will release 2TB-14 from -30 volts. The motor will decelerate to zero speed and the MA contactor will open. If the MA opens before the drive comes down to a stop, RSTOP is set too high. If the MA fails to open, RSTOP is set too low. Push the RESET button to drop out MA prior to removing power. RSTOP should be adjusted with power removed.

GAIN, RESPONSE, DAMP, AND COMP (Stability adjustments)

1. Set DAMP potentiometer at minimum 7 o'clock position.
2. Place the Diagnostic switch in the static mode. Adjust CUR REF for 2.5 volts at test pin CFB. This is equivalent to rated armature current.
3. Set COMP potentiometer by reading at the CEMF test pin a value equal to 0.0312 (240V - motor CEMF) for 240V drives. For 500V drives use .0148 (500V - motor CEMF).
Typical values of motor counter EMF.

MOTOR HORSEPOWER	MOTOR COUNTER EMF	
	240V	500V
5 to 15	215	455
20 to 40	225	470
50 to 125	230	480
150 to 250	—	490

The reading at CEMF test pin is a voltage proportional to motor CEMF

Example: 20 to 40 HP @ 240V

$$\text{CEMF} = 0.0312 (240 - 225) \\ = 0.468 \text{ volts}$$

The COMP potentiometer is now set for proper

operation. Regardless of overload range of IOC setting this is correct and should not be changed.

4. Set the GAIN adjustment to minimum 7 o'clock position.
5. Set LIN TIME potentiometer at minimum 7 o'clock position.
6. Set RESPONSE potentiometer at minimum 7 o'clock position.

When the drive is functioning properly in all other respects make small incremental step increases in speed. Observe armature current for bumping repeatedly before steady state speed is attained.

Increase the RESPONSE setting (move CW) until bumpy current is observed. Then reduce the RESPONSE setting until no bumps (or only one) is observed. This is the maximum RESPONSE setting.

In general, setting below 10 o'clock will show signs of increasing sluggishness. Settings greater than 2 o'clock may show signs of hard or even continuous bumping. Full RESPONSE setting (5 o'clock) will usually trip the IOC.

7. Reset LIN TIME to required setting.

TROUBLE SHOOTING

Although many of the problems which may arise can be effectively located with a multi-meter, an oscilloscope is a very powerful trouble shooting tool. The only requirements are that the selected scope have a dc input capability and a line synchronization mode. Caution should be exercised in measuring any point with a possible high potential with any instrument; however, particular care should be taken with an oscilloscope since the common clip is normally connected directly to the instrument case. If the grounded plug has not been defeated it will cause a short circuit between the high potential point under test and ground.

RECOMMENDED INSTRUMENTATION

Simpson Multi-meter (or equivalent). 10,000 ohms/volt (or higher)

Hewlett-Packard or Tektronix (or equivalent). Dual Trace oscilloscope rated for operation from dc to 10 MHz at 0.01V/CM with deflection factors to provide 0.01 V/cm to 1300V peak to peak deflection when used with appropriate attenuator probes.

PROCEDURES

In trouble shooting this drive system the most appropriate place to start is to follow the SEQUENCE OF OPERATION (previously described) until a discrepancy or fault is noted. This step by step procedure will determine which part, sub assembly or printed circuit card is causing

the problem

Included in this procedure is the use of the built-in Diagnostic Card (DGC) (or Test Circuit Fig. 27. This is another powerful tool for quickly locating drive system faults.

If the malfunction is a performance problem, then the quickest way to discover the problem is to follow the CALIBRATION PROCEDURE (previously described). There are two calibration procedures (1) With Motor Field Control (MFC) and (2) With Motor Field Exciter (MFE).

Detailed adjustments for these two cards are found in GEK-24971 for the MFC card and GEK-24972 for the MFE card.

HOW TO TEST AN SCR

WARNING

ELECTRIC SHOCK CAN CAUSE PERSONAL INJURY OR LOSS OF LIFE. WHETHER THE AC SUPPLY IS GROUNDED OR NOT, HIGH VOLTAGES TO GROUND WILL BE PRESENT AT MANY POINTS THROUGHOUT THE SYSTEM.

1. Disconnect the ac power and make sure the loop contactor (MA) is open.
2. Using a multi-meter selected to read ohms on the times 1K scale, check the forward and reverse resistance of SCR cell pairs. This is done by reading across power terminals T1 and DA1, T2 and DA1, T3 and DA1 for power conversion module SCRA (upper). Check the lower modules SCRB by reading across power terminals T1 and DA2, T2 and DA2, T3 and DA2. Be sure that the DC fuse DCFU is not open in the above.

SCR Description	Forward Reading	Reverse Reading
Good SCR	100K to Infinity	100K to Infinity
Shorted SCR	Zero	Zero
Inoperative SCR	1 to 2K	100K to Infinity
Open SCR	100K to Infinity	100K to Infinity

3. Since an open SCR will give about the same resistance reading as a good SCR another method must be used to find this type of fault. It should be pointed out; however, that practically all cells fail by shorting and very few by opening. If an open SCR is suspected or it is desired to check the switching operation of an SCR, the following circuit should be used:

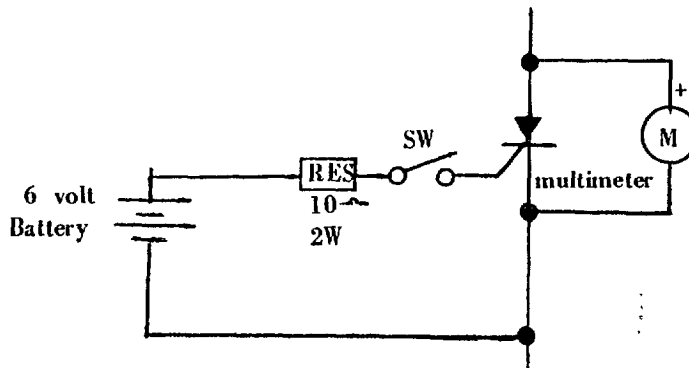

Fig. 28A

The multimeter is selected to read ohms on the 1K scale, and is connected to read the forward resistance of the SCR. When switch SW is closed, the forward resistance of a good SCR will change from a high value (100K to infinity) to a low value (1 to 10K). When the switch is opened a good SCR will revert to its high forward resistance or blocking state, if the holding current (multi-meter battery) source is momentarily removed. A faulty SCR will not switch remaining in either an open or a conducting state.

4. If any SCR's are suspected of being faulty from the above resistance checks, the appropriate SCR conversion module should be removed from the case. After the SCR cathode and gate leads have been disconnected, recheck the forward and reverse resistance before replacing the SCR heatsink assembly. This should be done before any SCR is definitely classified as damaged or faulty, since a fault in another SCR or another part of the circuitry can produce faulty reading from a good SCR before it is disconnected from the circuit.

REMOVAL/REPAIR

CONVERSION MODULE

The conversion module is best removed as follows:

Disconnect the three AC input power and DC output leads as shown. Slide module to right and pull out.

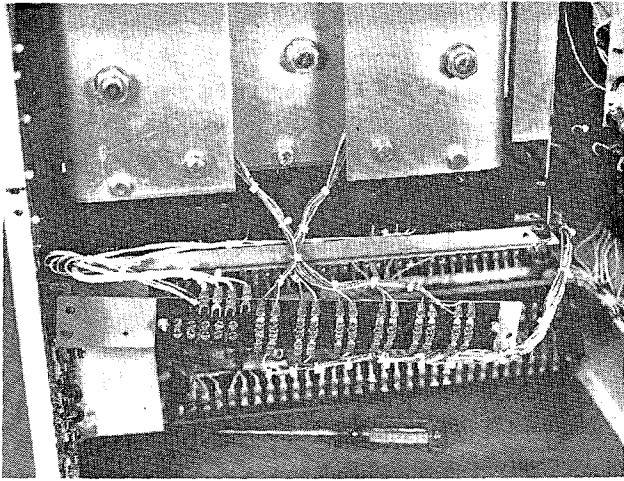

(Photo MG-5236-7)

Figure 29. Removal of Gate Leads

Disconnect the SCR gate leads from the terminal. If markings are not legible, remark prior to removal. It is not necessary to remove MTB to remove gate leads.

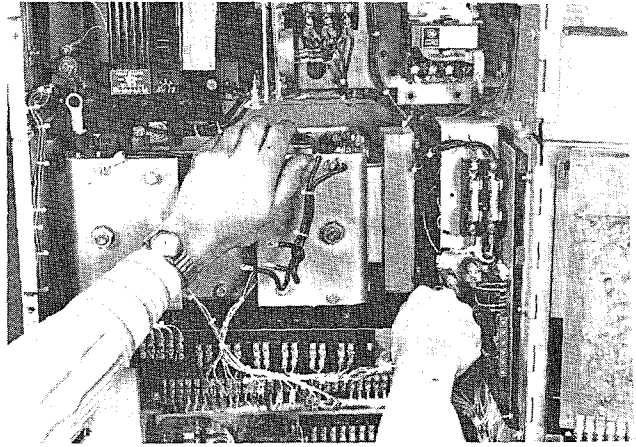

(Photo MG-5236-10)

Figure 30. Removal of Slotted Spacer

Loosen two nuts on the right hand side and remove the slotted spacer.

FANS (if supplied)

Remove the fan wires from the terminal board assembly and remove the two screws holding the terminal board assembly to the fan shelf. Loosen the two nuts on the bottom of the fan bracket and slide the fan bracket out.

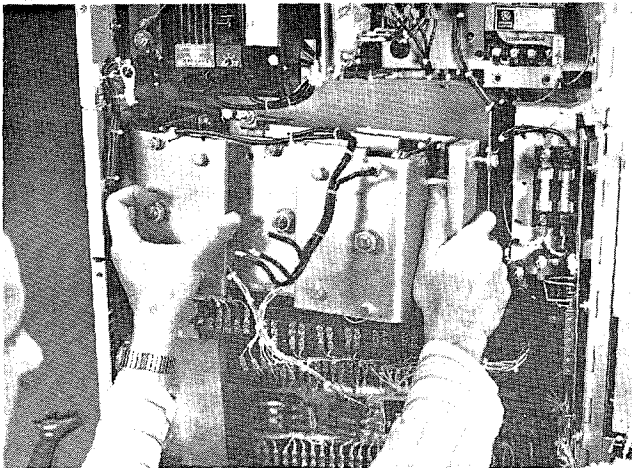

(Photo MG-5236-22)

Figure 31. Removal of Conversion Module

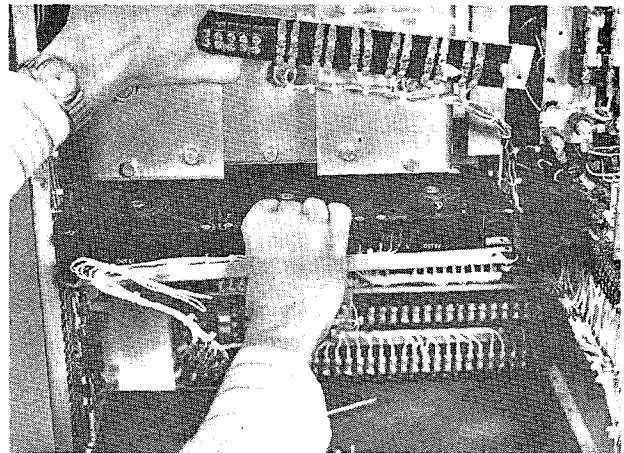

(Photo MG-5236-23)

Figure 32. Removal of Fans

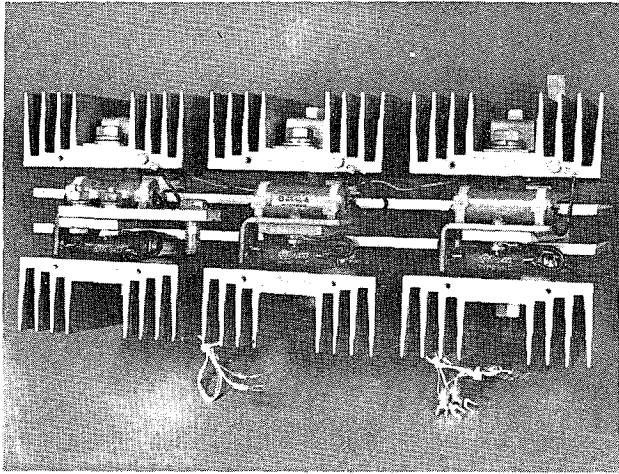

(Photo MG-5236-18)

Figure 33 Press Par SCR Heat Sink (Top View)

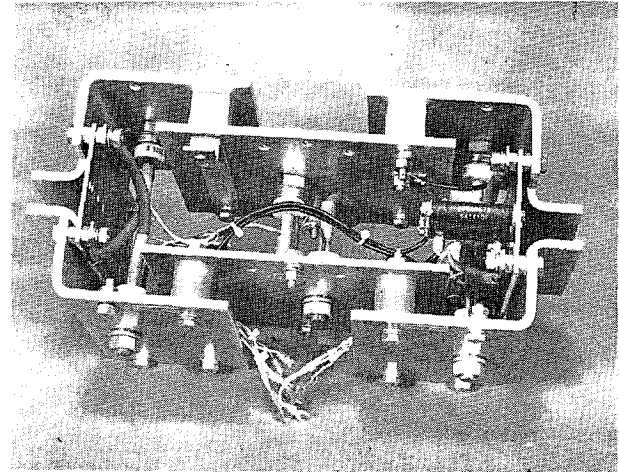

(Photo MG-5236-27)

Figure 34. Stud Mount Heat Sink (Top View)

SCR REPLACEMENT

The joint between the SCR and the heat sink performs two functions: (1) it carries the current and (2) it conducts the heat out of the SCR. To perform these functions properly, special care must be taken when reassembling an SCR to the heat sink as follows:

STUD MOUNT SCR'S

Clean all surfaces of old lubricant and stray dust. Apply a thin film of General Electric G322L VERSI-LUBE* lubricant and tighten with a torque wrench to the following specifications:

PRESS PAK SCR'S

Clean both surfaces of old lubricant and dust. Apply a thin film of General Electric G322L VERSILUBE. Line up the assembly and evenly tighten the nuts finger tight. Tighten the nuts, one at a time, alternating between nuts according to the following specifications.

CELL THICKNESS

1/2", 5/8"
1"

TORQUE

40 inch lbs.
80 inch lbs.

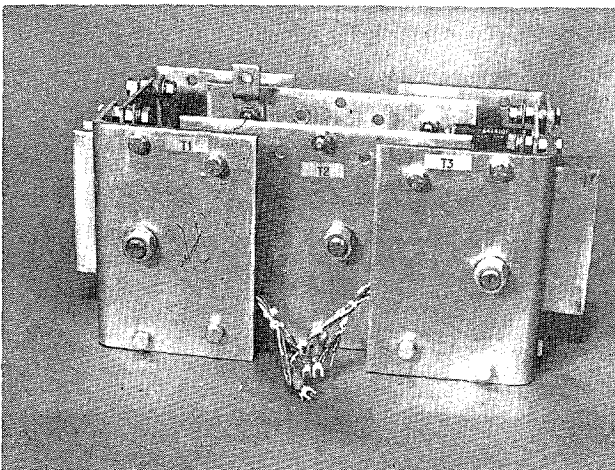

(Photo MG-5236-26)

Figure 35. Stud Mount Heat Sink (Front View)

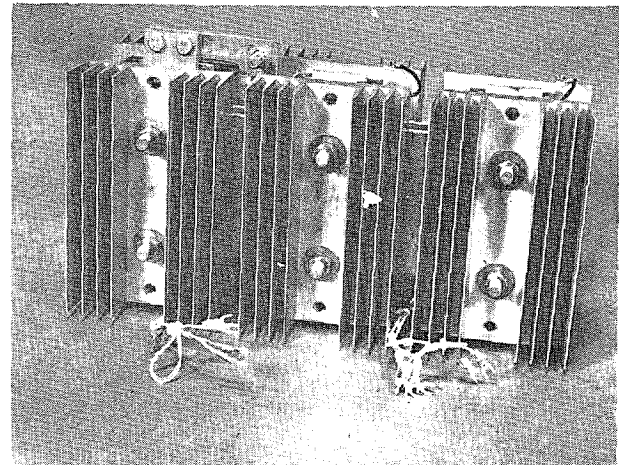

(Photo MG-5236-24)

Figure 36. Press Park SCR Heat Sink (Front View)

*Registered Trademark, General Electric Company, U.S.A.

NOTE

THERE SHOULD BE NO NEED TO RETUNE THE DRIVE AFTER REMOVAL/REPAIR OF A CONVERSION MODULE. AN SCR OR ANY OTHER REMOVABLE SUB-ASSEMBLY UNLESS OF COURSE AN ADJUSTMENT WAS INADVERTENTLY MOVED OR DISTURBED. IF A PRINTED CIRCUIT CARD IS REPLACED (OTHER THAN THE POWER SUPPLY CARD PSC):

1. ADD STAB-ON JUMPERS TO THE REPLACEMENT CARD JUST LIKE THE JUMPERS ON THE CARD THAT WAS REPLACED OR AS LISTED ON THE SYSTEM ELEMENTARY DIAGRAM "PROGRAMMING" TABLE.
2. ADD STAB-ON RESISTORS AND CAPACITORS TO THE REPLACEMENT CARD JUST LIKE THE COMPONENTS ON THE CARD THAT WAS REPLACED OR AS SHOWN WITH VALUES ON THE SYSTEM ELEMENTARY MAIN CONTROL CARD (MCC) AT STAB-ON TERMINALS. TL, RJ, SFB, NDE, CL1, LT, AND CLJ OR ON THE DM1, DM2, ETC. TERMINALS OR ANY OTHER PRINTED CIRCUIT CARD.
3. SET THE POTENTIOMETERS ON THE REPLACEMENT PRINTED CIRCUIT CARD TO THE POSITION AS WAS SET ON THE CARD THAT WAS REPLACED OR TO THE POSITION SHOWN ON THE TEST DATA SHEET. RECHECK THE RECALIBRATION PROCEDURES DESCRIBED.

GLOSSARY OF TERMS

	Page
ALIGN – Tachometer Loss Align Adjustment	30
*CEMF – Counter EMF	13,26,27,28,29,30,31,32
CEMF LIMIT – Counter EMF Limit Adjustment	12,26,29,30,31
*COM – Regulator Common	13,18
COMP – IR Compensation Adjustment	12,27,28,29,30,31,32
CPT – Control Power Transformer	10,19
*CFB – Current Feedback	13,22,26,27,28,30,31,32
CUR REF – Diagnostic Current Reference Potentiometer	27,29,30,31
CROSS – Crossover Adjustment	12,29
CUR LIMIT – Current Limit Adjustment	12,26,28,29,30,31
DA1 – Positive Armature Connection	16,33
DA2 – Negative Armature Connection	16,33
DAMP – Dampening Adjustment	12,26,27,30,32
Diagnostic – Normal	32
Diagnostic – Run	28,30,31
Diagnostic – Static	29
DGC – Diagnostic Card	16,20,33
*DM1–DM8 Dummy Input/Output points	13
*DP1–DP2 Diagnostic Switching signals	13,28
*DR – Driver Reference	13,26,28
*EAO – Error Amplifier Output	13,26
EST – External Fault Stop	18
FLT – Fault Relay	14,18,19,21
F1–F2 – Motor Field Connections	16
*FC – Field Current Signal	13,29
FDR – Field Diagnostic Reference	27,28
FEA – Field Economy Adjust	
FF – Field Fault	
FLOSS – Field Loss Adjustment	29,31
FMAX – Motor Field Maximum Adjustment	29
FMIN – Motor Field Minimum Adjustment	29
GAIN – Speed Loop Gain Adjustment	12,26,30,32
IFC – Interface Card	14
IMET – Current (Load) Instrument Output and Adjustment	14,19,28,29,31
*IPU – Initial Pulse	13,25,27
*JOG – Jog Switch Input	13,19,26,27,28
*JOGR – Jog Reference	13,26,27,28
L1,L2,L3 – AC Power Connections	16,17
LIN TIME – Linear Timing Adjustment	12,26,28,29,31,32
*LR – Local Reference From DGC	13,20,28,29
LOC REF – Diagnostic Local Reference Potentiometer	20,21,27,28,29,30,31

* Test Points Located on Door Front (See MCC Illustration, Fig. 12)

GLOSSARY OF TERMS

(continued)

	Page
MA — Line Contactor	19,30,32
*MAG — MA Control Signal	13,19
MAX — Pilot Relay for MA	18,19,27
MAX SPEED — Adjustment	12,19,29,30,31
MCC — Main Control Card	10
MDR — Modification Rack	10,16
MFC — Motor Field Control Card	(1)12,15,26,27,29,32
MFE — Motor Field Exciter Card	(2)12,15,27,30,32
MIN SPEED — Adjustment	12,19,20,30,32
MOV — Metal Oxide Varistor	16
MSW — Mode Switch	
*OSC — Oscillator	13,24,27
P1 — Motor Thermal Switch Output	21
P2 — Motor Thermal Switch Output	21
*PCR — Phase Control Reference	13,27,28
PO — Pulse Outputs	24,25,26,27,28
*PRE — Preconditioning	13,19
PSC — Power Supply Card	10,12
REF SCALE — Adjustment	12,19,28,29,30,32
RESPONSE — Speed Loop Response Adjustment	12,26,29,30,31,32
RESET — Pushbutton	18,21,27,28,30,31,32
RSTOP — Regenerative Stop Adjustment	14,21,30,32
*RTR — "Ready to Run" Indicator	13,20,21
*RUN — Run Switch Input	13,18,19,27
RPM — Reversing Power Module	6,11
SCR — Power Conversion Module	12,27,33,35,36
*SA,SB,SC — Synchronizing Signals	13,19,24
*SFB — Speed Feedback	13,28,29,30,31,32
SLIM — Speed Limit Adjustment	29
*SMAX — Maximum Speed Adjustment and Output	13,29,31
*SMET — Speed Instrument Output and Adjustment	12,14,19,29,30,31
*SMIN — Minimum Speed Reference Adjustment and Input	13,19,29,30
*SR — Speed Reference	13,19,26,27,28,30,32
*SYS — System Fault Trip	13,21
*TA — Tachometer Align Output	13,29,30
TF — Tach Fault	(1)
*TFB — Tachometer Feedback Signal	13,24,25
TKN — Negative Tachometer Input	19
TKP — Positive Tachometer Input	19
*TR — Timed Reference	13,19,26,27,28,29,30
TRIP — Fault Trip Amplifier Output (On Interface Card)	14
TRIP — (On Main Control Card and Auxiliary Control Card) Trip Signal for Optional Circuit Breaker	13,16
*TEST Points Located on Door Front (See MCC Illustration, Fig. 12)	

(1) Also see Motor Field Control Instructions, GEK-24971

(2) Also see Motor Field Exciter Instructions, GEK-24972

**GLOSSARY OF TERMS
(Continued)**

	Page
UTS – Up To Speed	15
* VFB – Voltage Feedback	13, 22, 25, 27
* WFR – Weak Field Reference	(1), 13
XO – Isolation Transformer	10
XO – Secondary Neutral	10, 15
XO – Negative Armature Connection	10, 15
* Test Points Located on Door Front (See MCC Illustration, Fig. 12)	
(1) Also see Motor Field Control Instructions, GEK-24971	
(2) Also see Motor Field Control Exciter Instructions, GEK-24972	

NOTES

**GENERAL ELECTRIC COMPANY
SPEED VARIATOR PRODUCTS OPERATION
ERIE, PENNSYLVANIA 16531**

GENERAL  ELECTRIC