



INSTRUCTIONS—SCR ELECTRIC VEHICLE CONTROL

1A-BYPASS CONTACTOR CONTROL SYSTEM CURRENT HOLD-OFF, THERMAL HOLD-OFF

1C4484B603 FOR 24-48-VOLT OPERATION

1C4484B602 FOR 72-80-VOLT OPERATION

Before any adjustments, servicing, parts replacement or any other act is performed requiring physical contact with the electrical working components or wiring of this equipment, DISCONNECT THE BATTERY AND DISCHARGE CAPACITOR 1C.

FUNCTION

This card will control the 1A contactor in both modes or individually.

- (1) 1A CURRENT HOLD-OFF (RH2): This mode will inhibit the closing of the 1A contactor until the SCR current drops to a pre-set value.
- (2) 1A THERMAL HOLD-OFF (RH1): This mode will inhibit the closing of the 1A contactor if the SCR panel is in thermal cutback.

Turning the trimpots fully CW disables the function.

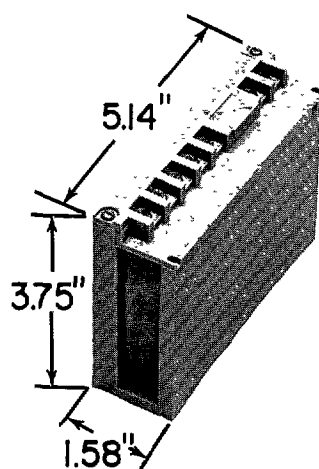

Fig. 1

These cards are not compatible with ramp start card unless the 1A timer circuit has separate inputs for ramp start and 1A hold off.

OPERATION AND TUNE-UP

1A CURRENT HOLD-OFF: Connect an ammeter and shunt between battery negative and 1 REC. Jack the drive wheels off the floor. Jumper the brake switch if so equipped. Turn RH1 fully CW and RH2 fully CCW.

- (1) Depress the accelerator fully to the floor and operate the brake to get the desired current point.
- (2) Turn RH2 CW until 1A closes. This will always be some value less than full SCR stall. 1A should close at a value less than the set point, but not close above it.

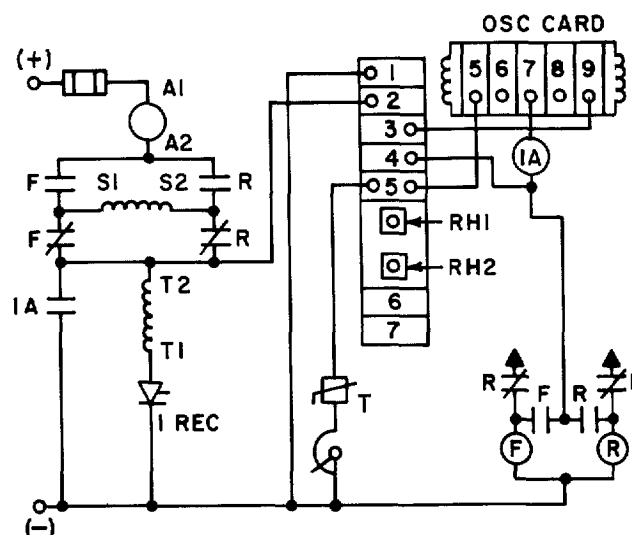

Fig. 2. Typical circuit

The information contained herein is intended to assist truck users and dealers in the servicing of control furnished by the General Electric Company. It does not purport to cover all details or variations in equipment or provide for every possible contingency to be met in connection with installation, operation or maintenance.

Should further information be desired or should particular problems arise which are not covered sufficiently for the purchaser's purposes, the matter should be referred to the truck manufacturer through his normal service channels, not directly to General Electric Company.

GEK-31527, 1A-Bypass Contactor Control System

1A THERMAL HOLD-OFF:

TABLE A

(1) Turn RH1 fully CCW. Disconnect the two leads from the Thermal Protector (T. P.) and connect the proper resistance from Table A to the leads removed from T. P.

Resistance	Speed (SCR Range)
3,300 Ohm 1/2 W	33%
2,700 Ohm 1/2 W	46%
2,200 Ohm 1/2 W	58%
1,800 Ohm 1/2 W	68%

(2) Depress accelerator into 1A switch position. Turn RH1 CW until 1A contactor closes.

(3) Remove all test equipment and reconnect leads to T. P.

GENERAL ELECTRIC COMPANY
INDUSTRIAL CONTROL PRODUCTS DEPARTMENT
SALEM, VA. 24153

GENERAL  ELECTRIC