



HIGH SPEED AUXILIARY RELAYS

TYPE HGA14

DESCRIPTION

INTRODUCTION

The relays covered by these instructions are double-pole, hinged armature, continuously rated, auxiliary relays. The HGA14BA relay is front connected and the HGA14BB relay is back connected.

OPERATING CHARACTERISTICS

The HGA14BA and HGA14BB relays are so constructed that the pick-up time is approximately 1/2 cycle, (60 cycle basis). Extra strong contact springs are used to eliminate bounce resulting from such high-speed operation.

RATINGS

The HGA14BA and HGA14BB relays are continuously rated at the nameplate voltage when the included resistor is inserted in series with the operating coil.

The current closing rating of the contacts is 20 amperes. The current carrying rating is 12 amperes continuously or 30 amperes for one minute. Interrupting ratings for non-inductive circuits for the various voltages are tabulated in Table I.

TABLE I

VOLTS AMP.	DC				AC	
	24	48	125	250	115	230
	10	5	0.6	0.25	20	10

BURDENS

TABLE II

Relay	Voltage	Coil Resistance (Ohms)	External Resistance (Ohms)	Watts+
HGA14BA	250	160	1500	37.6
HGA14BB	125	160	750	17.2
	48	3.42	200	11.3

+ Burden of coil and external resistor in series.

CONSTRUCTION

The contact circuits of these auxiliary relays are opened and closed by moving contact arms controlled by a hinge type armature which in turn is actuated by an operating coil and restrained by an adjustable control spring. Lengths of the contact and armature gaps are adjusted by a screw contact and locknut in the right hand front contact position. The armature gaps (and back contact wipe) can also be controlled by the screws and locknuts located on the moving contact arms.

These instructions do not purport to cover all details or variations in equipment nor to provide for every possible contingency to be met in connection with installation, operation or maintenance. Should further information be desired or should particular problems arise which are not covered sufficiently for the purchaser's purposes, the matter should be referred to the General Electric Company.

INSTALLATION

LOCATION AND MOUNTING

The location should be clean and dry, free from dust and excessive vibration, and well lighted to facilitate inspection and testing.

The HGA14BA and HGA14BB are for surface mounting. The HGA14BB(-)F is designed for semi-finish mounting. The outline and panel drilling diagram for this relay is shown in Fig. 6. The outline and panel drilling diagrams for the surface mounted relays are shown in Figs. 4 and 5.

The outline of the external resistor used with the HGA14BA and HGA14BB relays is shown in Fig. 3.

CONNECTIONS

The internal connection diagram for both relays is shown in Fig. 2. A schematic wiring diagram is shown in Fig. 1. Ascertain that the proper external resistor is connected in series with the operating coil and that the normally closed or "b" contact is connected across this resistor before applying rated voltage to the relay.

TO INITIATING CONTACTS

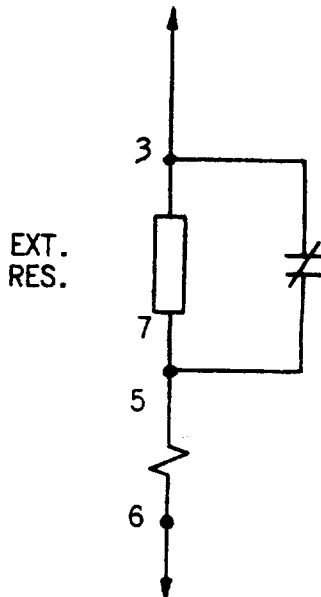

TO NEGATIVE BUS

Fig. 1 Schematic Wiring Diagram of HGA14BA and HGA14BB Relays

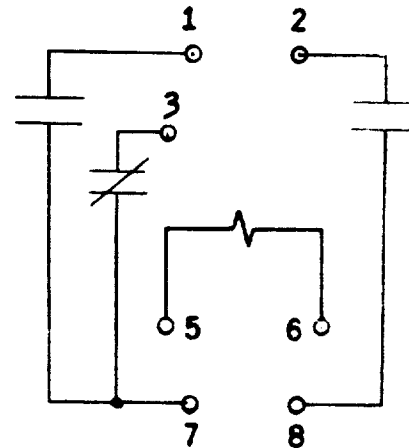

Fig. 2 Internal Connection Diagram of HGA14BA and HGA14BB Relay (Back View)

MAINTENANCE

CONTACTS

CLEANING

For cleaning fine silver contacts, a flexible burnishing tool should be used. This consists of a flexible strip of metal with an etched roughened surface resembling, in effect, a superfine file. The polishing action is so delicate that no scratches are left, yet corroded material will be removed rapidly and thoroughly. The flexibility of the tool insures the cleaning of the actual points of contact.

Fine silver contacts should not be cleaned with knives, files, nor abrasive paper or cloth. Knives or files may leave scratches which increase arcing and deterioration of the contacts. Abrasive paper or cloth may leave minute particles of insulating abrasive material in the contacts and thus prevent closing.

The burnishing tool described above can be obtained from the factory.

WIPE AND GAP

The minimum recommended normally-open contact wipe is 0.005-inch as measured with a feeler gage between the projections on the molded contact support and the ends of the wipe adjusting screws. Both normally open contacts should make simultaneously.

Minimum recommended contact gap is 1/16-inch. This adjustment can be conveniently obtained by turning the screw contact in the right-hand front contact position in until the normally open contacts are just making, and then backing it off 3-3/4-turns. The contact screw should be locked securely in place by means of the locknut.

It should be noted that these adjustments are for minimum recommended contact gap and wipe. If the contact gaps are made shorter, the interrupting ratings listed will no longer apply.

PICKUP

The HGA14BA and HGA14BB relays are adjusted at the factory to pickup and wipe-in at approximately 80 percent of nameplate rating.

CAUTION:

Relay rated volts should never be applied to the relay coil alone.

PERIODIC TESTING

Auxiliary relay equipment should be checked for operation at regular intervals, preferably at the same time the associated devices are inspected.

RENEWAL PARTS

It is recommended that sufficient quantities of renewal parts be carried in stock to enable the prompt replacement of any that are worn, broken, or damaged.

When ordering renewal parts, address the nearest Sales Office of the General Electric Company, specifying the quantity required and describing the parts by catalogue numbers as shown in Renewal Parts Bulletin No. GEF-2623.

Fig. 3 (384A752-2)

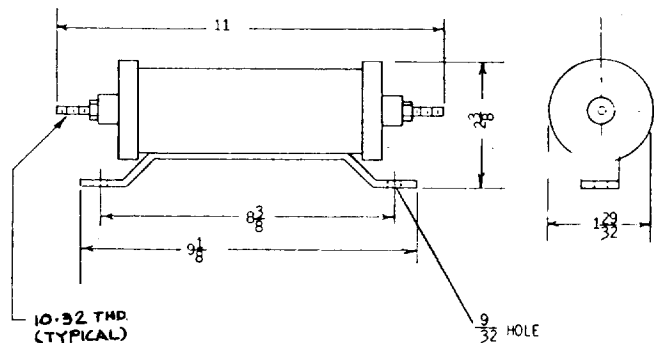

Fig. 3 Outline of External Resistor Used With HGA14BA and HGA14BB Relays

Fig. 4 (377A139-2)

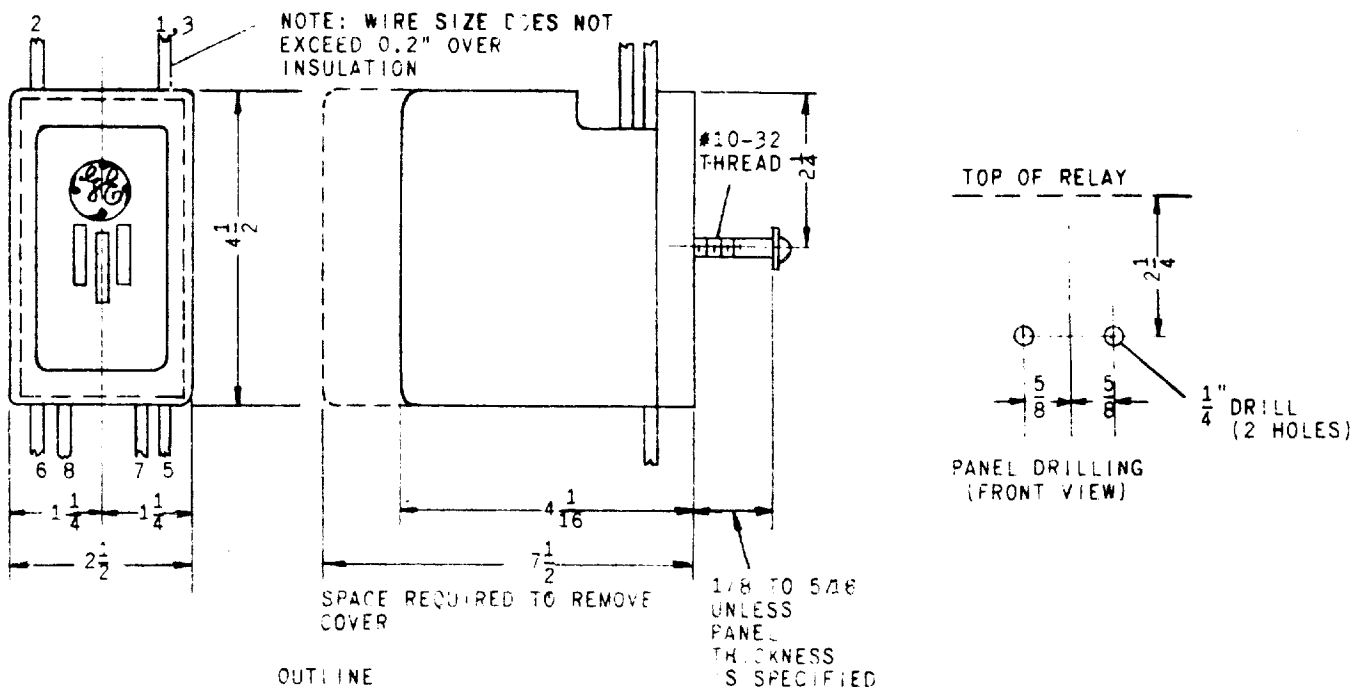

Fig. 4 Outline and Panel Drilling Diagram for HGA14BA Relay (Surface Mounted)

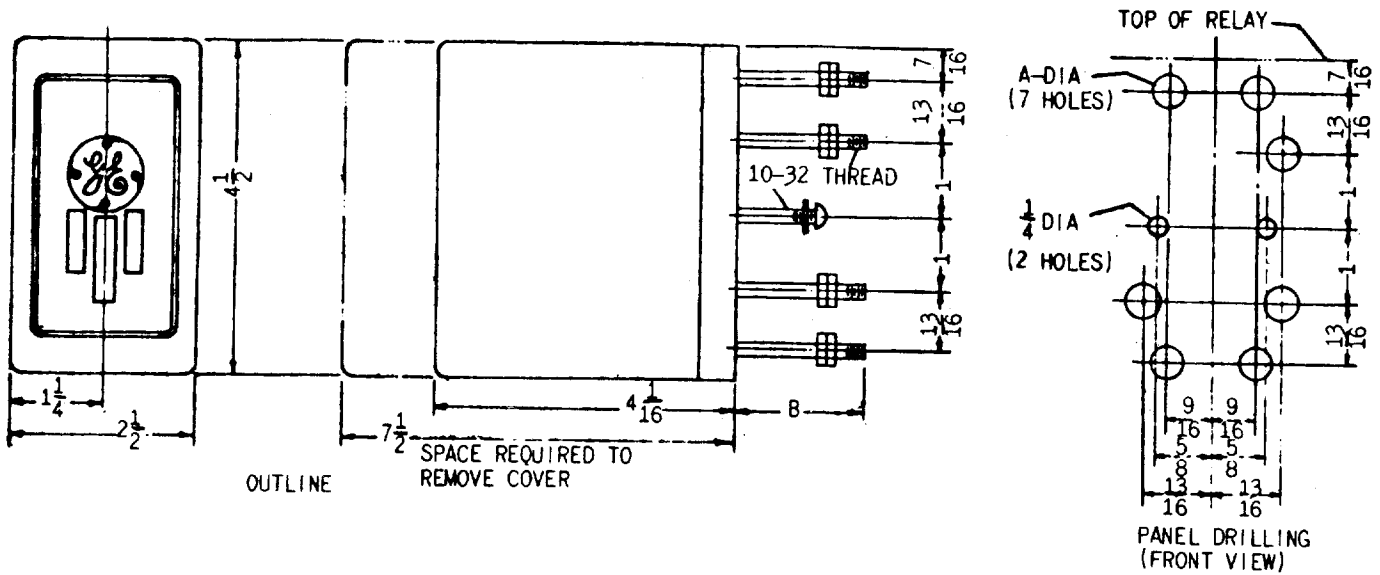

Fig. 5 Outline and Panel Drilling Diagram for HGA148B Relay (Surface Mounted)

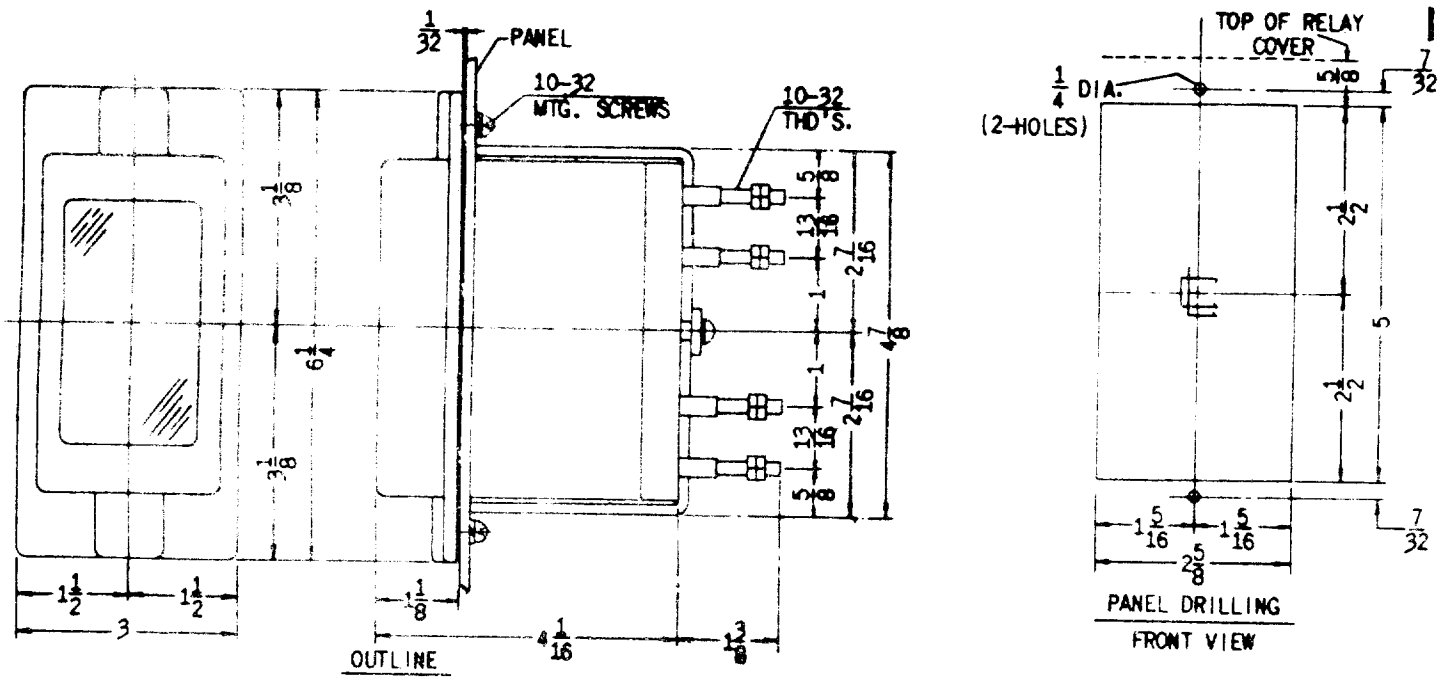

Fig. 6 Outline and Panel Drilling Diagram for HGA148B Relay (Semi-flush Mounted)