

INSTRUCTIONS

**INDUCTION TIME
OVERCURRENT RELAYS**

TYPES

IAC11A	IAC11F
IAC11B	IAC11H
IAC11C	IAC12A
IAC11D	IAC12B
IAC11E	IAC12C

IAC12D

IN UNIVERSAL CASE

GENERAL  ELECTRIC

SCHENECTADY, N.Y.

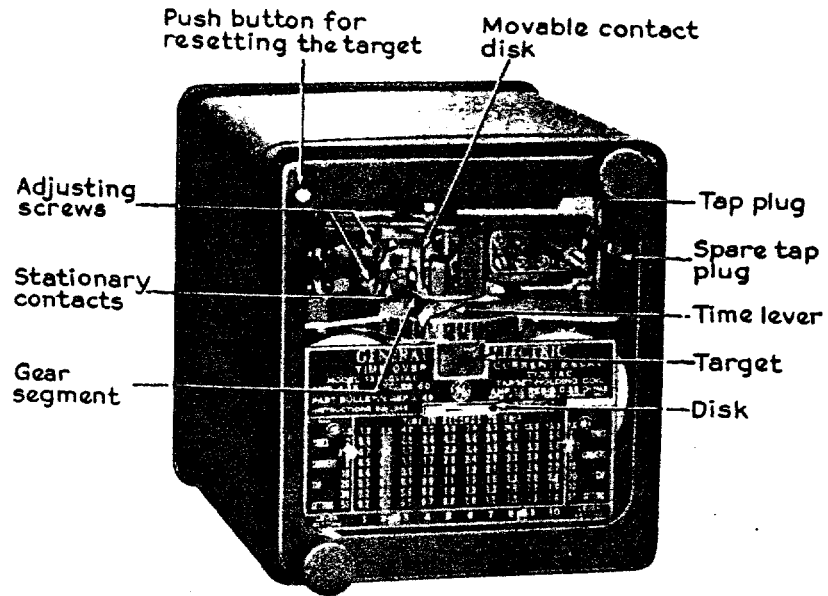

Fig. 1. Front View of Relay

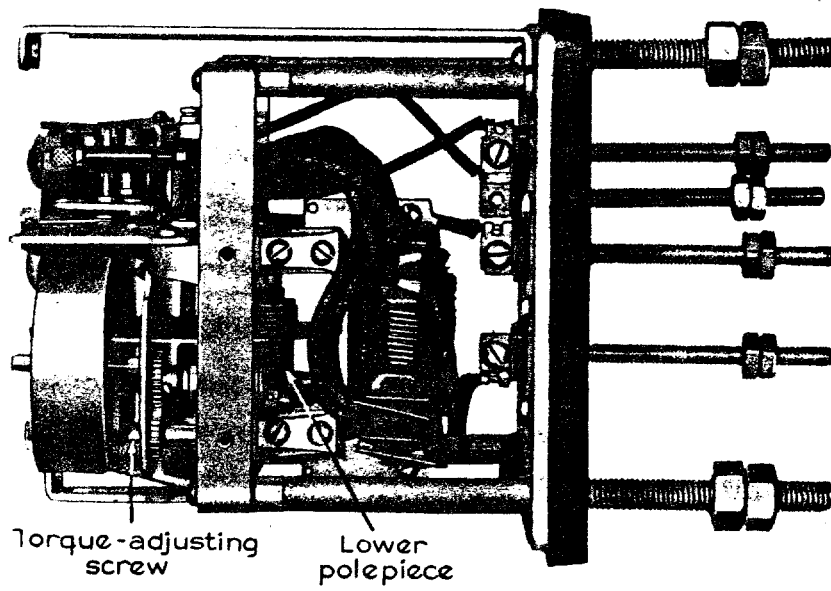

Fig. 2. Side View of Relay with Cover Removed

INDUCTION TIME OVERCURRENT RELAYS

TYPE IAC

The Type IAC relays comprise a group of relays that are employed to protect against over-current on single-phase and polyphase circuits. The various relays in this IAC group are identified by Model Numbers, and the relays differ in the number of circuits they close, the length of time delay, and features that are determined by the characteristics of the protected circuit. Instructions for any relay in the IAC group other than those covered by this book may be obtained from the nearest Sales Office of the Company by stating the Model No. that appears on the relay nameplate.

The instructions for all of the several relays in the IAC group are so nearly alike that they are presented in the following manner. First, all instructions applicable to the IAC11A are given in the following section. Following this section, beginning on page 9, are sections on each of the remaining relays; these sections treat each relay in turn with reference to the IAC11A.

IAC11A RELAY

The IAC11A relay is a single-phase relay having single-throw contacts that close one circuit after a time delay when the current passing through the relay reaches a predetermined value. This relay is designed to use any one of three operating coils, each having a different combination of taps, as follows: 4, 5, 6, 8, 10, 12, and 15 amperes; 0.5, 0.6, 0.8, 1.0, 1.5, 2.0, and 2.5 amperes; 1.5, 2.0, 2.5, 3.0, 4.0, 5.0, and 6.0 amperes.

The burden of the 4/15 amp, 60-cycle relay, measured at 5.0 amperes, 60 cycles on the 4-amp tap is 0.14 ohm effective resistance and 900 microhenries or 9.1 volt-amperes, 3.4 watts.

The burden of the 0.5/2.5-amp, 60-cycle relay, measured at 0.5 amperes, 60 cycles on the 0.5 amp tap is 7.21 ohms effective resistance and 55,000 microhenries, or 5.50 volt-amperes, 1.80 watts.

The burden of the 1.5/6.0 amp, 60-cycle relay, measured at 1.5 amperes, 60 cycles on the 1.5-amp tap is 0.775 ohms effective resistance and 6350 microhenries, or 5.6 volt-amperes, 1.75 watts.

INSTALLATION

The relay should be installed in the vertical position in a location that is dry and clean and also well-lighted to facilitate periodic testing and inspection.

It may be noted that the relay cover is released for removal by turning the two knurled cover screws about one complete revolution.

The diagrams in Fig. 5 and 6 show the manner in which it is recommended that single-phase relays be connected in the circuit for various operating conditions.

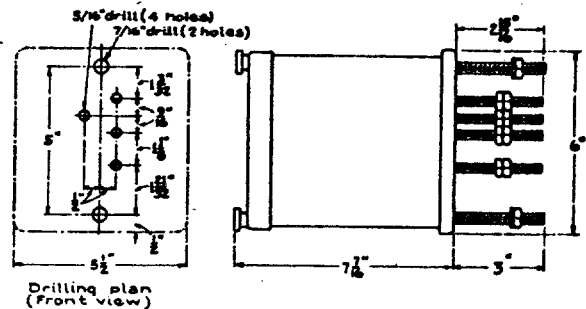

Fig. 3. Outline Dimensions and Panel Drilling

It is recommended that the frame of the relay be connected from one of the supporting studs to a permanent ground, using No. 12 B & S copper wire or its equivalent for this purpose.

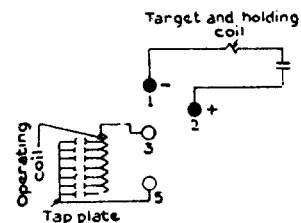

Fig. 4. Internal Connections (Back View)

If the Purchaser wishes to mark the relay with an identifying serial number it is recommended that this number be placed on either side of the relay frame.

GEH-846E Type IAC Induction Time Overcurrent Relays

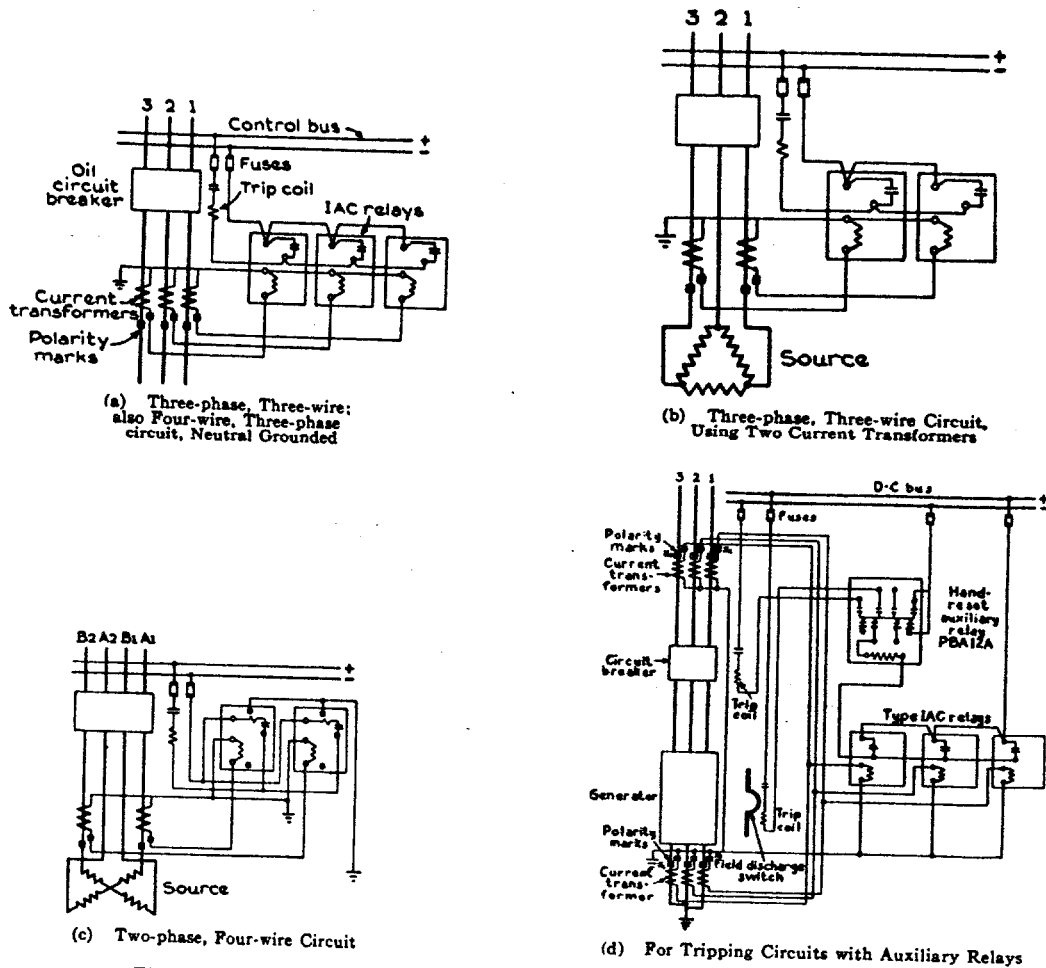

Fig. 5. Typical Wiring Diagrams, Using Relays with D-c Control Power

The current-closing rating of the contacts is 30 amperes for voltages not exceeding 250 volts. The current-carrying ratings are limited by the two different ratings of target as indicated in the following table.

Function	AMPERES, A-C OR D-C	
	1 Amp (0.25 Ohm) Target and Holding Coil	0.2 Amp (7 Ohm) Target and Holding Coil
Tripping Duty	30	5
Carry Continuously	4	0.8

The 0.2-ampere coil is for use with trip coils that operate on currents ranging from 0.2 up to

1.0 ampere at the minimum control voltage. If this coil is used with trip coils that take 1.0 ampere or more, there is a possibility that the 7-ohms resistance will reduce the tripping current to so low a value that the breaker will not be tripped. This coil can safely carry tripping currents as high as 5 amperes.

The 1.0 ampere coil should be used with trip coils that take 1.0 ampere or more at the minimum control voltage, provided the tripping current does not exceed 30 amperes at the maximum control voltage. If the tripping current exceeds 30 amperes, an auxiliary relay must be used to control the trip coil circuit, the connections being such that the tripping current does not pass through the contacts or the target and holding coil of the protective relay.

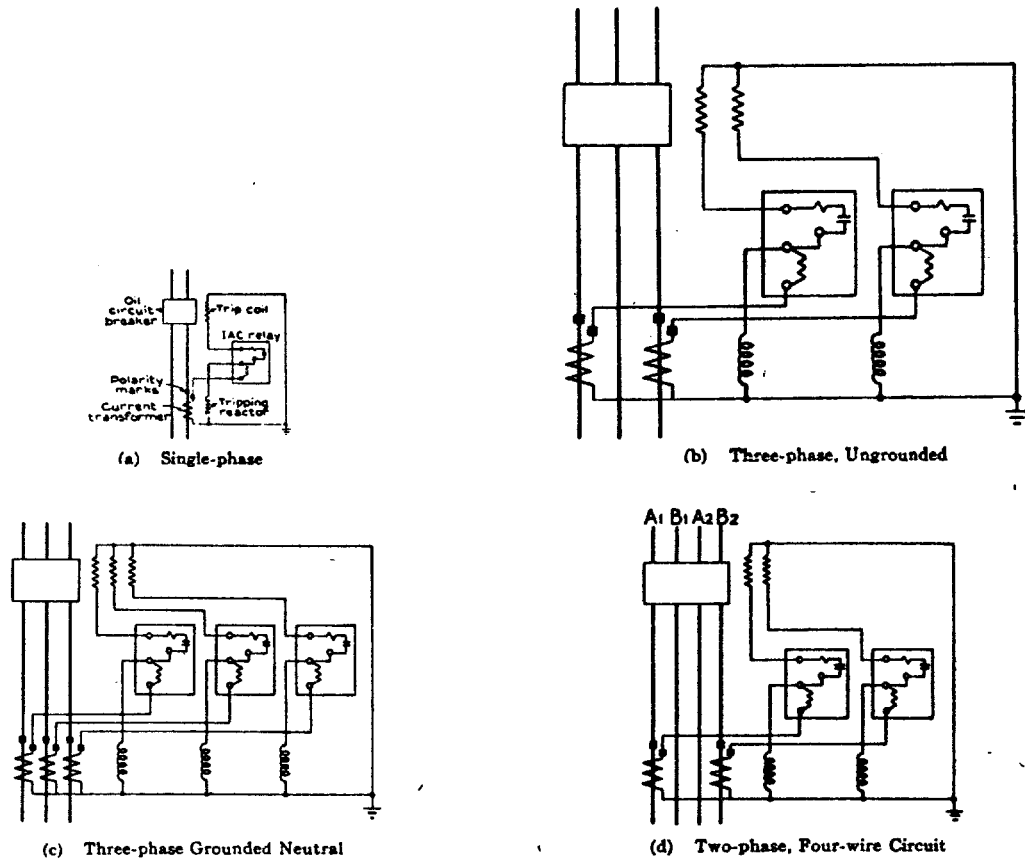

Fig. 6. Typical Wiring Diagrams, Using Relays with Tripping Reactors

When it is desirable to adopt one type of relay as standard to be used anywhere on a system, relays with the 1.0-ampere coil should be chosen. These relays should also be used when it is impossible to obtain trip coil data, but attention is called to the fact that the target may not operate if used with trip coils taking less than 1.0 ampere.

APPLICATION

See that the frequency of the circuit is the same as that stamped on the nameplate of the relay, since any variation in frequency or wave form affects the operation of the relay.

Current Setting

Screw the tap plug (see Fig. 1) firmly into the tap marked for the desired current (below which the relay is not to operate).

When changing the current setting with the relay in service, screw the spare plug into tap marked for the desired current and then remove the other plug. This avoids opening the current transformer secondary circuit.

Do not let both plugs remain permanently in the tap plate, and do not remove both when the circuit is energized.

Time Setting

The setting of the time lever (see Fig. 1) on the time scale determines the length of time the relay requires to close its contacts when the current reaches the predetermined value. The contacts are just closed when the lever is set on 0. When the lever is set on 10 the disk must travel the maximum amount to close the contacts and therefore this setting gives the maximum time setting.

GEH-846E Type IAC Induction Time Overcurrent Relays

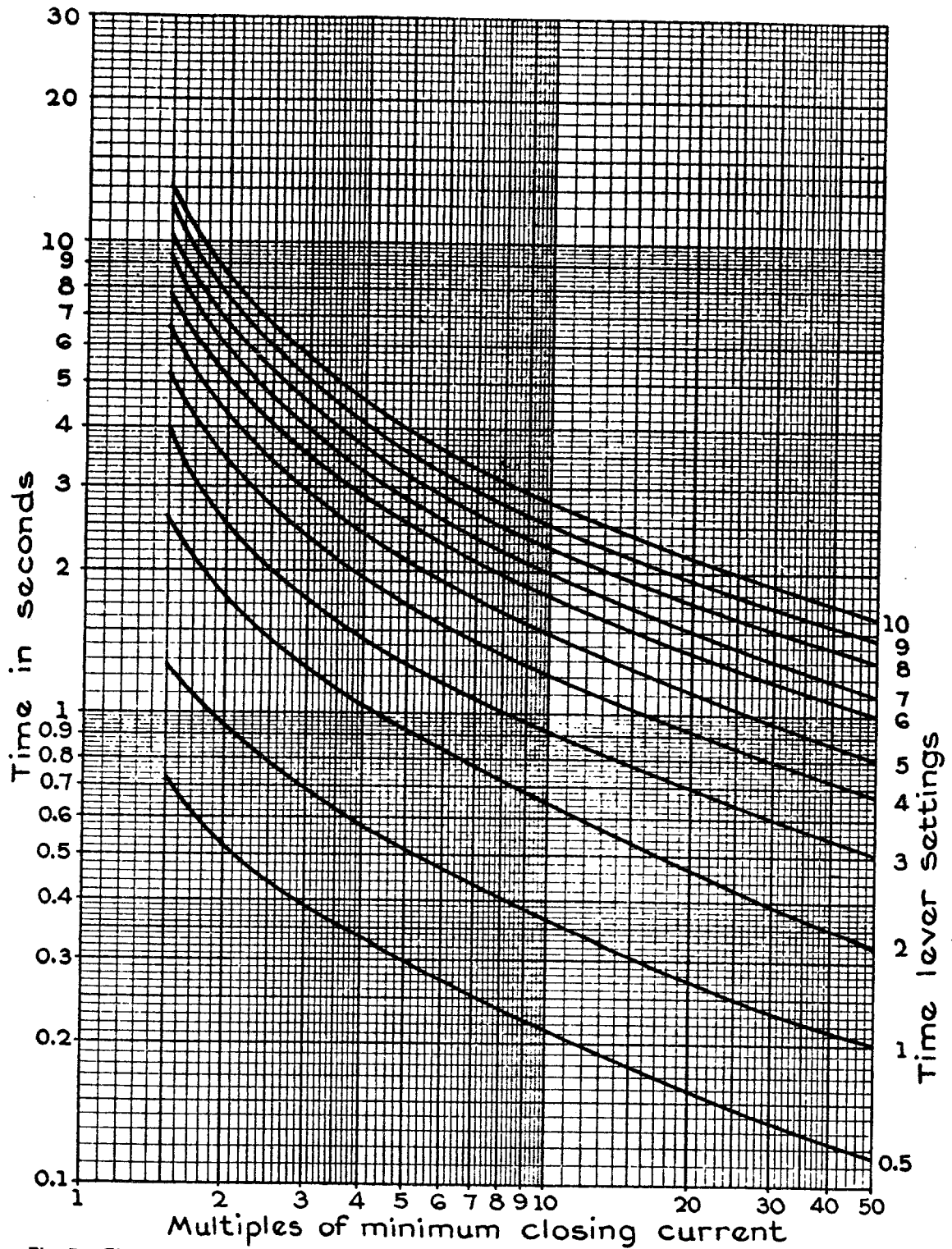

Fig. 7. Time-current Curves for Various Time-lever Settings Taken on Type IAC11A, Single-phase, Overcurrent Relays

If selective action of two or more relays is required, determine the maximum possible short-circuit current of the line and then choose a time value for each relay that differs sufficiently to insure the proper sequence in the operation of the several circuit breakers.

The heading "Time in Seconds to Trip" on the index plate refers to the time of operation of the unit from starting of overcurrent to the instant of contact closing. Additional allowance must be made for the time involved in opening each breaker after the relay contacts close. For this reason, unless the circuit time of operation is known with accuracy, there should be a difference of about 0.5 second (at the maximum current) between relays whose operation is to be selective.

Example of Setting

The time and current settings of Type IAC relays can be made easily and quickly. Each time value listed on the nameplate, indicates the time required for the contacts to close with a particular time-lever setting when the current is a prescribed number of times the current-tap setting. In order to secure any of the particular time-current settings shown on the nameplate, insert the removable plug in the proper tap receptacle and adjust the time in the proper position. The following example illustrates the procedure in making a relay setting.

Assume an IAC relay in a circuit where the circuit breaker should trip on a sustained current of approximately 450 amperes; also the breaker should trip in 1.9 seconds on a short-circuit current of 3750 amperes. Assume further, that current transformers of 60/1 ratio are used.

The current-tap setting is found by dividing the minimum primary tripping current by the current transformer ratio. In this case, 450 divided by 60 equals 7.5 amperes. Since there is no 7.5-ampere tap, the 8-ampere tap is used. To find the proper time-lever setting to give 1.9 seconds time delay at 3750 amperes, divide 3750 by the transformer ratio. This gives 62.5 amperes secondary current which is 7.8 times the 8-ampere setting. By referring to the time-

current curves (Fig. 7), it will be seen that 7.8 times the minimum operating current gives 1.9 seconds time delay when the relay is set slightly below the No. 6 item-lever setting.

The above results should be checked by means of an accurate timing device, such as the MF timer. Slight readjustment of the lever can be made until the desired time is obtained.

Aid in making the proper selection of relay settings may be obtained on application to the nearest Sales Office of the Company.

ADJUSTMENT

The pick-up of the relay for any current tap is adjusted by means of a torque-adjusting screw (see Fig. 2) having a slotted end that protrudes through the front of the frame. This shaft is geared to the lower pole piece, by movement of which the operating current of the relay may be brought into agreement with the tap setting employed if, for some reason, this adjustment has been disturbed. This adjustment also permits any desired setting intermediate between the various tap settings to be obtained. The relay is adjusted at the factory to close its contacts from any time-lever position at a minimum current within 5 per cent of the tap-plug setting. The relay rests at 90 per cent of the minimum closing value.

The primary adjustment for the time of operation of the relay is made by means of the time lever. However, further adjustment is obtained by moving the permanent magnet along its supporting shelf; moving the magnet in towards the back of the relay decreases the time, while moving it out increases the time.

The time for the disk to reset completely to the No. 10 time-lever position when the relay is de-energized is about 6 seconds.

The target gives visible indication when current flows in the contact circuit. The target is reset by means of the push-button indicated in Fig. 1.

PERIODIC TESTING

The relay should be given a test and inspection at least once every six months. Connections for testing the relay are shown in Fig. 8.

GEH-846E Type IAC Induction Time Overcurrent Relays

If it is ever necessary to remove the contact-assembly plate, the following should be observed in re-meshing the gears. Place the time lever at

fine needle should be applied to the new jewel. Use only the finest grade of watch oil for this purpose.

Keep the cover on the relay, except when it is necessary to remove it for testing or adjustments.

It may be noted that the relay mechanism is mounted on four posts and may be removed as a unit for inspection without disturbing the base or panel wiring. Also, the vertical end play of the disk shaft may be adjusted by raising or lowering the guide pin at the top of the shaft, and locking it with a setscrew. The lower bearing is screwed in place and may also be raised or lowered and then locked in position.

The position of the stationary contacts is adjustable by means of the individual adjusting screws shown in Fig. 1.

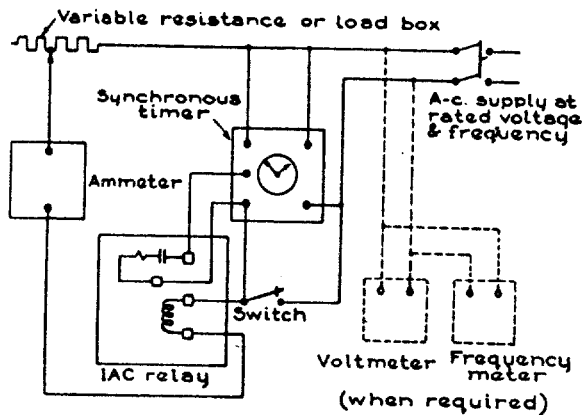

Fig. 8. Connections for Testing Single-phase Relay

No. 10 TLS. Allow the disk to come to rest; the hole in the drum through which the weight chain enters, should face the opening in the horizontal leg of the pulley housing. Turn the disk 90 deg counterclockwise. In this position of the disk, mesh the gear segment of the contact assembly with the pinion on the disk shaft, using about 65 per cent mesh. Move the time lever to zero; the weight should not touch the pulley. The weight mentioned here is the small weight that is suspended over a pulley by means of a chain and which is employed to return the disk to the reset position when the relay is de-energized. The chain, pulley and weight are enclosed in a molded tube to prevent the chain getting off the pulley.

CARE AND MAINTENANCE

To inspect the jewel bearing, insert the paper wedge between disk and damping magnet, remove the bearing, wipe the jewel carefully and move the point of a fine sewing needle lightly over the jewel surface to detect any fault. A cracked jewel should be replaced with a new one, inserting a new steel pivot at the same time.

No lubrication of the relay is required either at the time of installation or during service, except when a new jewel is installed; in this case a drop of oil such as will cling to the point of a

Contacts (Cleaning)

If the contacts become dirty or slightly pitted, they should be cleaned by scraping the surfaces lightly with a sharp knife or by using a fine, clean file. Under no circumstances should emery or crocus cloth be used on fine-silver contacts. Finish by wiping the contacts with a clean, soft cloth and avoid touching them with the fingers. Fine-silver contacts cleaned in this manner will remain in good operating condition for many months.

Contact Adjustment

When the contacts are just closed there should be enough space between the contact-holding armature and the poles of the holding-target magnet to permit the stationary contacts to be deflected about $\frac{1}{16}$ inch when the armature is finally pushed against its magnet poles.

The contact tips should be in the same vertical plane. These adjustments are readily secured by moving either or both contact brushes by means of the adjusting screws, in front of the brush block (Fig. 1), which engage the brushes near their middle.

The time lever should indicate zero on the time-lever scale when it is moved to the position where it will hold the contacts just closed. If it does not, and the contact brushes are correctly adjusted, shift the time-lever scale slightly

after loosening the two small screws holding it to the underside of the contact mechanism plate. Tighten these screws after the adjustment is made.

RENEWAL PARTS

When ordering renewal parts, describe the required part in detail and give the Model No. and rating of the relay as they appear on the relay nameplate.

In ordering target-and-holding coils, it should be noted that this coil is available in two ratings, 1 amp and 0.2 amp. The 1-amp coil is recommended if it is preferred to standardize on

and stock only one kind of coil, because with the 1-amp coil any contact-circuit current will be satisfactory for the entire range up to 30 amperes, but the target will not function on currents much below 1 ampere. The resistance of the 1-amp coil is $\frac{1}{4}$ ohm.

The 0.2-amp coil operates the target at 0.2 ampere or slightly less, but cannot be used with large tripping currents because of its high resistance (7 ohms).

At a current of approximately 2 amperes on the 1-amp coil, or approximately 0.5 ampere on the 0.2-amp coil, the contacts are sealed-in positively.

IAC11B RELAY

The IAC11B is a three-phase overcurrent relay consisting of three IAC11A relay units mounted on a common base and enclosed in one case.

The time-current characteristic curves are the same as given for the IAC11A relay.

The outline and panel drilling dimensions and the internal connections are given in Fig. 9 and 10.

With these exceptions, the instructions for the IAC11B relay are the same as given for the IAC11A relay.

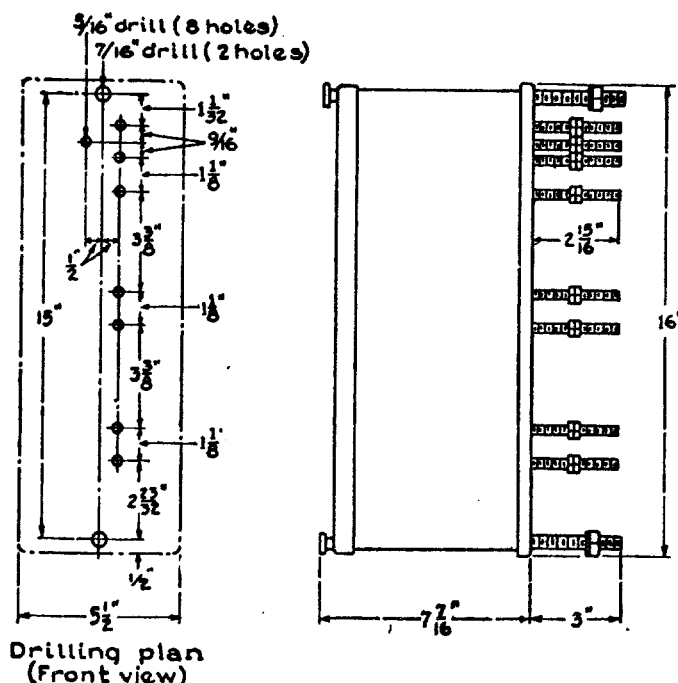

Fig. 9. Dimensions of IAC11B Relay
(Also IAC11D and IAC11E)

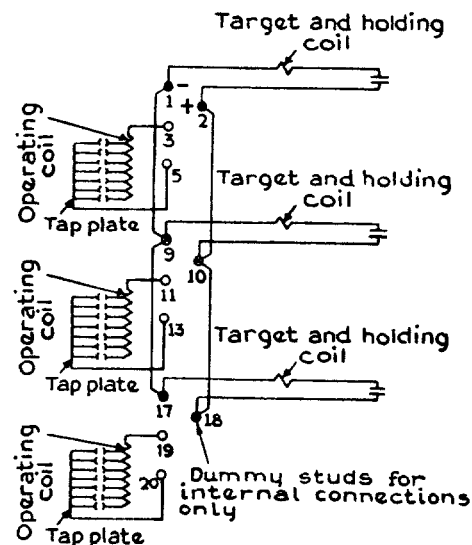

Fig. 10. Internal Connections

IAC11C, IAC11D, IAC12C, AND IAC12D RELAYS

These relays are similar to the IAC11A relay and have the standard inverse-time characteristic shown for that relay in Fig. 7. These relays differ from the IAC11A in that each unit in a relay is provided with a current-indicator attachment similar to an ammeter. The readings of the current indicator are unaffected by the relay tap settings.

The IAC11C is a single-unit relay with single-circuit closing contacts.

The IAC11D is a three-unit relay with single-circuit closing contacts.

The IAC12C is a single-unit relay with two-circuit closing contacts.

The IAC12D is a three-unit relay with two-circuit closing contacts.

The outline dimensions of the IAC11C are the same as given for the IAC11A in Fig. 3. The dimensions of the IAC11D are the same as for the IAC11B in Fig. 9. The dimensions of the IAC12C are the same as for the IAC12A in Fig. 20. The dimensions of the IAC12D are like the IAC12B in Fig. 23. The internal connections of the four relays are given on page 11.

Measured on the 4-ampere tap, the burden imposed by each unit (including the current indicator) in the 4/15-ampere range is as follows:

	Effective Resistance	Microhenries	Volt-amp	Watts
60-cycle relay measured on 60 cycles.....	0.15	960	9.4	3.8
25-cycle relay measured on 25 cycles.....	0.12	1275	6.0	3.0

The standard 5-ampere current indicator will carry 9 amperes continuously without injury.

CARE AND ADJUSTMENT OF CURRENT INDICATOR

The current indicator will require no care as long as the pointer moves freely and resets to zero properly. Excessive friction which will interfere with free movement of the pointer may be detected by displacing the end of the pointer about $\frac{1}{4}$ inch first to one, and then to the other, side of its position of rest; when released it should return to substantially the same position from either side.

Friction may be caused by foreign particles in the damping magnet air gap, by the pointer touching the scale, or by damaged or incorrectly adjusted bearings.

The bearing pivots, at the ends of the moving element shaft, present a highly polished appearance and have pointed ends that are fairly sharp when in good condition. The "V" jewels should feel smooth when explored by a fine needle point. A very small drop of General Electric meter jewel oil, Cat. 66X728, may be placed in the "V" jewel before the jewel screws are replaced; this always should be done to new jewels.

Correct adjustment of the jewel screws will locate the damping vane in the center of its air gap and will limit the end play of the shaft to the smallest amount that permits free movement of the pointer. It is advisable to tighten the jewel-screw locknuts before checking the end play finally.

If the pointer does not reset to zero when the relay is de-energized, and if this does not appear to be caused by friction, it may be corrected by moving the adjustable support for the outer end of the control spring.

* * * * *

With the exception of the information given here, the instructions for these four relays are the same as given for the IAC11A relay.

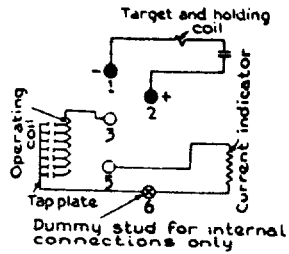

Fig. 11. Internal Connections of IAC11C Relay

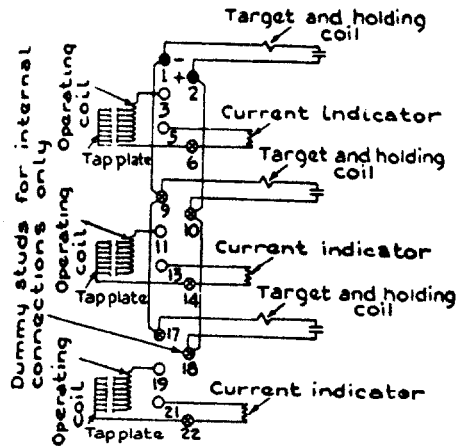

Fig. 12. Internal Connections of IAC11D Relay

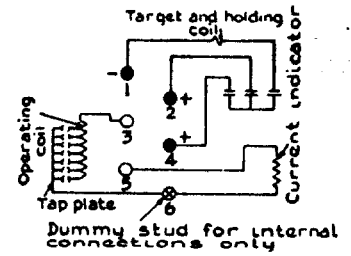

Fig. 13. Internal Connections of IAC12C Relay

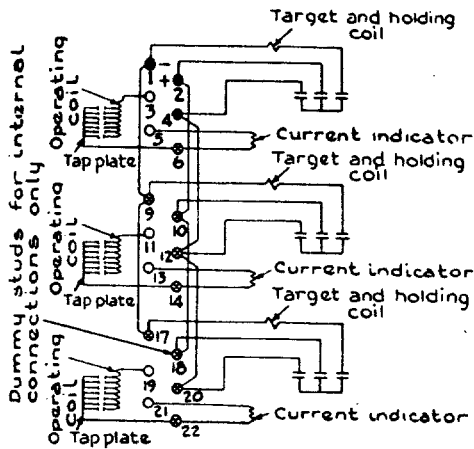

Fig. 14. Internal Connections of IAC12D Relay

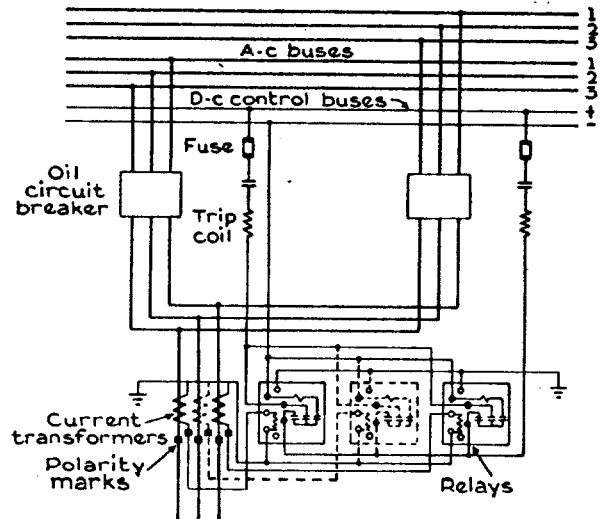

Fig. 15. Wiring Diagram Showing External Connections of IAC12C Relay

IAC11E, IAC11F, AND IAC11H RELAYS

The IAC11E is a single-phase overcurrent relay consisting of an IAC11A relay unit and, in addition, a small instantaneous plunger-type device mounted on the back of the frame opposite the tapped operating coil. This device operates to close the contact circuit in very fast time when the current passing through the relay reaches a predetermined value. The IAC11F is like the IAC11E, with the addition of a current-indicator attachment. The IAC11H is like the IAC11E except that it has three units in one case.

The outline and panel-drilling dimensions of the IAC11E and IAC11F are the same as for the IAC11A relay, as given in Fig. 3, and the IAC11H is the same as for the IAC11B. The internal connections are different and are shown here. The time-current characteristic curves for the instantaneous element are shown below, but the curves for the relay proper are the same as given for the IAC11A relay in Fig. 7.

The additional burden imposed on the relay by the coil of the instantaneous device is very small. The burden of the 4/15-amp 60-cycle relay, with the 10- to 40-amp instantaneous device, measured on the 4-amp tap at 5 amperes, 60 cycles, is 9.7 volt-amperes, or 3.9 watts.

INSTANTANEOUS ATTACHMENT

The instantaneous attachment, when used in the above relays, is mounted on the rear of the frame opposite the tapped operating coil with which its coil is connected in series. Its contacts

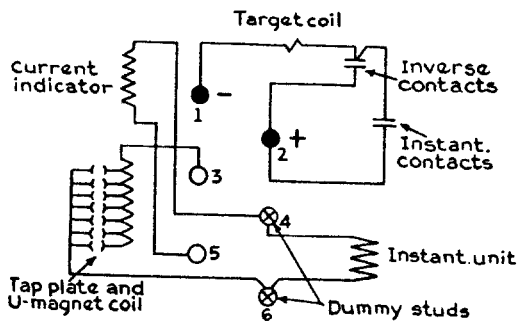

Fig. 16. IAC11F Internal Connections

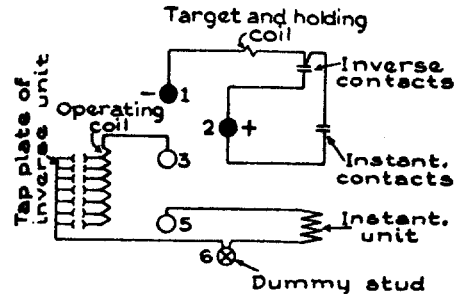

Fig. 17. IAC11E Internal Connections

are normally connected, internally, in parallel with the contacts of the induction unit.

Operation

The instantaneous attachment operates over a 4 to 1 range and has its calibration stamped on the tube surrounding the plunger. The five different coils that are available for use have current ranges of 2 to 8, 4 to 16, 10 to 40, 20 to 80, and 40 to 160 amp respectively. The pickup is adjusted by raising or lowering the plunger. This is done by turning the adjusting worm stud having a slotted end protruding through the permanent magnet shield at the lower left-hand corner. Turning this adjusting worm stud in a

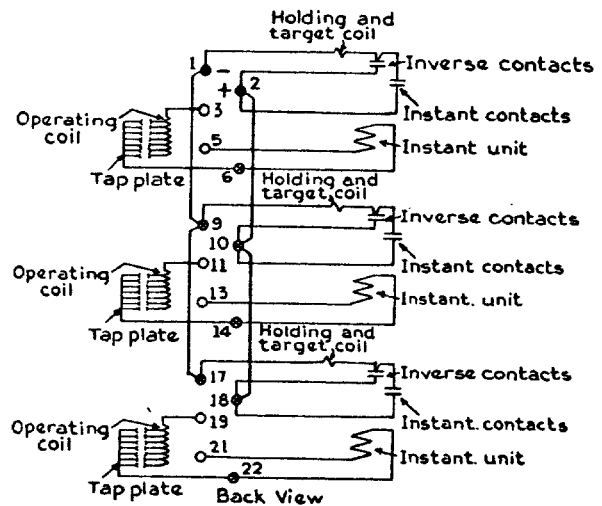

Fig. 18. IAC11H Internal Connections

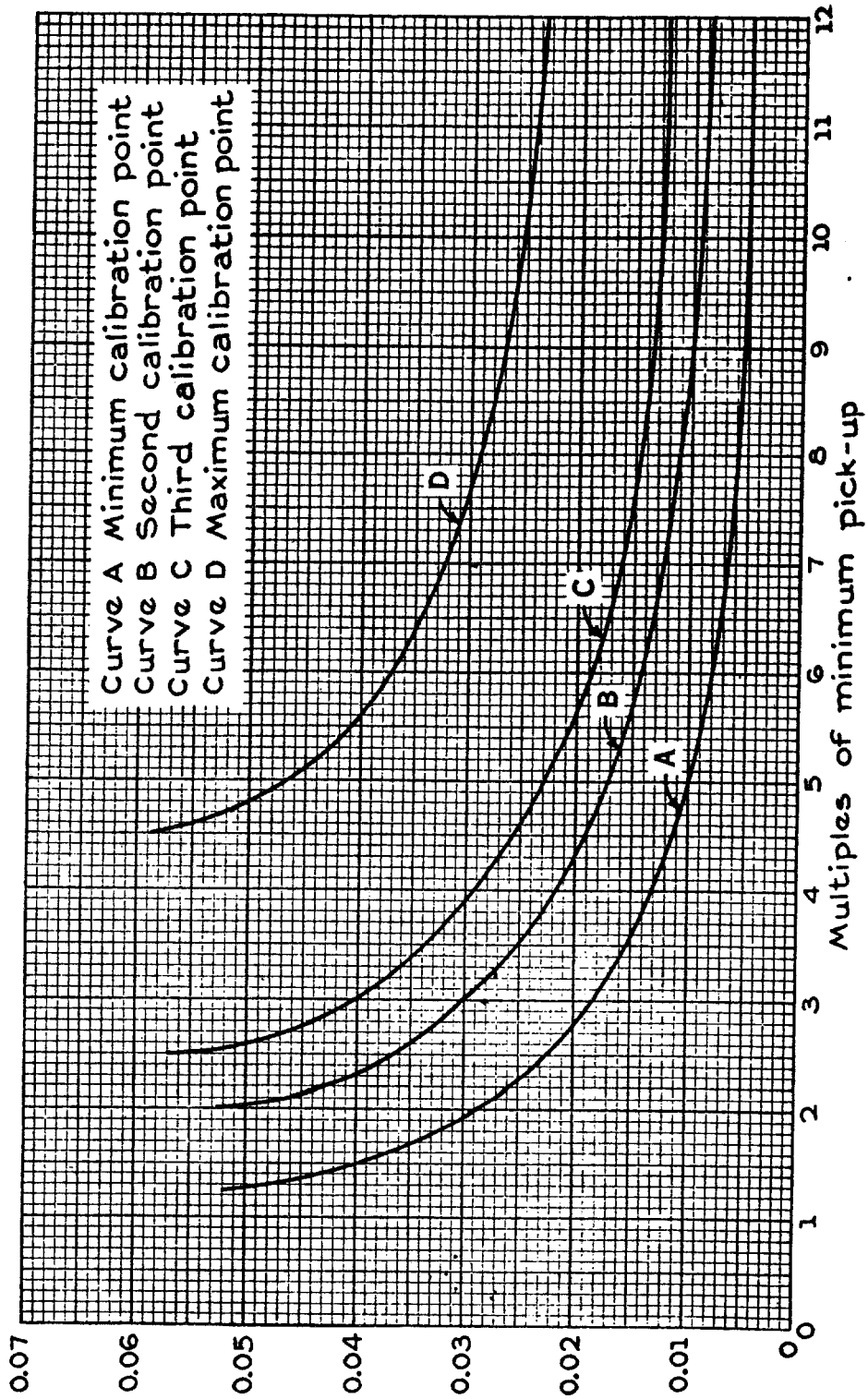

Fig. 19. Time-current Curves for Instantaneous Element

GEH-846E Type IAC Induction Time Overcurrent Relays

counterclockwise direction raises the plunger to obtain a lower pickup current value and in a clockwise direction to lower the plunger to obtain a higher pickup current value.

The time-current curves for the instantaneous attachment are given in Fig. 19.

Contact Adjustment

The contact tips should be in the same horizontal plane and about $\frac{1}{16}$ inch from the silver

disk when the plunger is down. The contacts should close, when the plunger is raised to its highest position, and the contact tips should be deflected vertically at least $\frac{1}{16}$ inch before striking the two stop screws. These stop screws also determine the "drop-out" of the instantaneous attachment.

With these exceptions, the instructions for the IAC11E, IAC11F, and IAC11H relays are the same as given for the IAC11A relay.

IAC12A RELAY

The IAC12A is a single-phase overcurrent relay similar to the IAC11A relay except that it has three single-throw contacts that close two circuits with a common contact when the current passing through the relay reaches a predetermined value.

The time-current characteristic curves for this relay are the same as given for the IAC11A relay in Fig. 7.

The outline and panel-drilling dimensions and the internal connections are shown here.

A typical wiring diagram showing the method of connecting this three-contact relay as compared with the two-contact relay in Fig. 5 (d) is shown in Fig. 15.

With these exceptions, the instructions for the IAC12A are the same as given for the IAC11A relay.

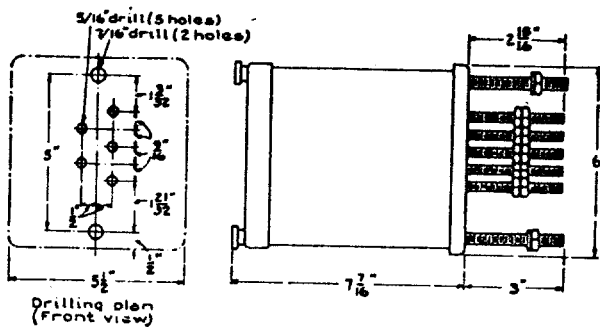

Fig. 20. Dimensions of IAC12A Relay
(Also IAC12C)

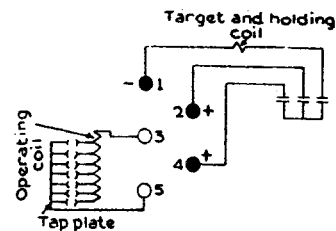

Fig. 21. Internal Connections
of IAC12A Relay

IAC12B RELAY

The IAC12B relay is a three-phase over-current relay consisting of three units mounted on a common base and enclosed in one cover. Each of the units is like the unit of the IAC11A relay except that they have three single-throw contacts that close two circuits with a common contact, when the current passing through the relay reaches a predetermined value.

The time-current characteristic curves for this relay are the same as given for the IAC11A relay in Fig. 7.

The outline and panel-drilling dimensions and internal connections are shown here.

With these exceptions, the instructions for the IAC12B are the same as given for the IAC11A relay.

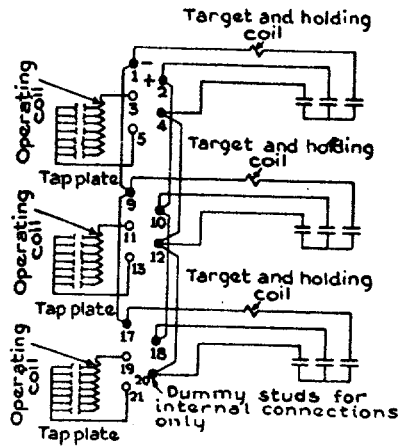

Fig. 22. Internal Connections

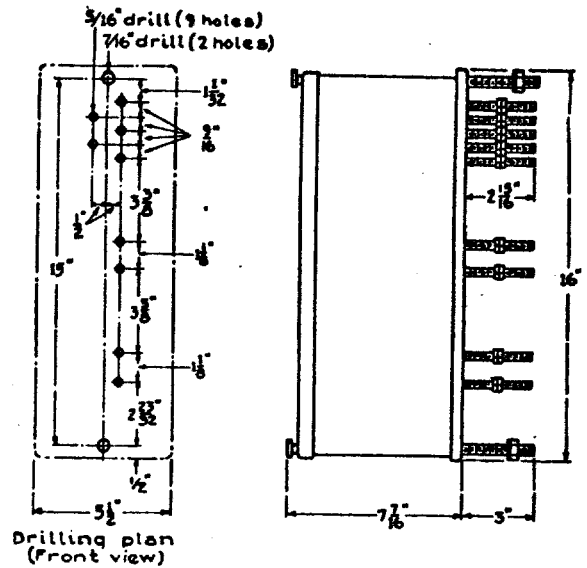

Fig. 23. Dimensions of IAC12B Relay