



INSTRUCTIONS

GROUND DIRECTIONAL OVERCURRENT RELAYS

TYPES

**IBCG51M
IBCG51M(-)Y1A
IBCG52M**

**IBCG53M
IBCG53M(-)Y1A
IBCG54M**

**IBCG77M
IBCG78M**

***GE Protection and Control
205 Great Valley Parkway
Malvern, PA 19355-1337***

CONTENTS

	<u>PAGE</u>		<u>PAGE</u>
DESCRIPTION	3	DIRECTIONAL UNIT	17
APPLICATION	4	CURRENT POLARIZATION	17
RATINGS	5	POTENTIAL POLARIZATION	17
TIME OVERCURRENT UNIT	6	INSTANTANEOUS UNIT	17
DIRECTIONAL UNIT	7	INSTALLATION	17
INSTANTANEOUS UNIT	7	LOCATION	17
TARGET AND SEAL-IN UNIT	8	MOUNTING.....	18
CONTACTS	8	CONNECTIONS	18
CHARACTERISTICS	8	INSPECTION	18
PICKUP	8	CAUTION	18
RESET (TIME OVERCURRENT UNIT)...	9	OPERATION	18
OPERATING TIME	9	TARGET AND SEAL-IN UNIT	18
BURDENS	9	TIME OVERCURRENT UNIT	18
CONSTRUCTION	11	DIRECTIONAL UNIT	19
DIRECTIONAL UNIT	11	CURRENT POLARIZATION.....	19
CONTACTS.....	11	POTENTIAL POLARIZATION	19
TIME OVERCURRENT UNIT.....	11	INSTANTANEOUS UNIT	19
TARGET SEAL-IN UNIT.....	12	PERIODIC CHECKS AND ROUTINE	
INSTANTANEOUS UNIT	12	MAINTENANCE	19
RECEIVING, HANDLING AND		TARGET AND SEAL-IN UNIT	19
STORAGE	12	TIME OVERCURRENT UNIT	19
ACCEPTANCE TESTS	13	DIRECTIONAL UNIT	19
VISUAL INSPECTION	13	INSTANTANEOUS UNIT	20
MECHANICAL INSPECTION	13	SERVICING	20
TOP UNIT (TOC)	13	TARGET AND SEAL-IN UNIT	20
BOTTOM UNIT (DIR)	13	TIME OVERCURRENT UNIT	20
TARGET AND SEAL-IN UNIT/ INSTANTANEOUS UNIT	13	DISK AND BEARINGS	20
DRAWOUT RELAYS, GENERAL	14	CONTACT ADJUSTMENT	20
POWER REQUIREMENTS, GENERAL	14	CHARACTERISTICS CHECK AND ADJUSTMENTS	20
TARGET AND SEAL-IN UNIT	14	DIRECTIONAL UNIT	21
PICKUP AND DROPOUT TEST	14	BEARINGS	21
TIME OVERCURRENT UNIT	15	CUP AND STATOR	21
CURRENT SETTING	15	CONTACT ADJUSTMENTS	21
TIME SETTING	16	BIAS TORQUE ADJUSTMENT	22
PICKUP TEST	16	CLUTCH ADJUSTMENT	22
TIME TEST	16	INSTANTANEOUS UNIT	23
		CONTACT CLEANING	23
		RENEWAL PARTS	23

GROUND DIRECTIONAL OVERCURRENT RELAYS

TYPES

IBCG51M	IBCG53M	IBCG77M
IBCG51M(-)Y1A	IBCG53M(-)Y1A	IBCG78M
IBCG52M	IBCG54M	

DESCRIPTION

The Type IBCG relays are ground directional overcurrent relays used primarily for the protection of feeders and transmission lines. They are available with either inverse, very inverse or extremely inverse time characteristics.

All the IBCG relays contain a time overcurrent unit of the induction disk type and an instantaneous directional unit of the induction cup type. The directional unit can be potential polarized, or current polarized, or both, and it directionally controls the operation of the time overcurrent unit.

A target seal-in unit is provided in each of the relays. The operating coil for this unit is connected in series with the contacts of the time overcurrent unit so that it will pick up whenever the time overcurrent unit operates. The contacts of the seal-in unit are connected in parallel with the contacts of the time overcurrent unit to provide protection for them and their associated control springs.

Those relays having the designation Y1A following the model number also contain a Hi-Seismic instantaneous overcurrent unit of the hinged armature construction.

The IBCG52M, 54M and the 78M relay models are the two-contact versions of the IBCG51M, 53M and the 77M relay models respectively.

All the IBCG relays are mounted in standard M1 size drawout cases, the outline and panel drilling dimensions for which are given in Figure 26. Internal connections for the relays are given in Figure 5, 6, 7, 8 and 9. Typical external connections are shown by Figures 10, 11 and 12.

Table I lists the various models and ranges that are available.

These instructions do not purport to cover all details or variations in equipment nor to provide for every possible contingency to be met in connection with installation, operation or maintenance. Should further information be desired or should particular problems arise which are not covered sufficiently for the purchaser's purposes, the matter should be referred to the General Electric Company.

To the extent required the products described herein meet applicable ANSI, IEEE and NEMA standards; but no such assurance is given with respect to local codes and ordinances because they vary greatly.

TABLE I
EXTENDED RANGE IBCG RELAYS

Relay Model	Time Characteristic	Inst Unit	Pickup Range Inst.	Time	Int Conn.
IBCG51M(-)A	Inverse	No	-	0.5-4, 2-16	Fig. 5
IBCG52M(-)A	Inverse	No	-	0.5-4, 2-16	Fig. 7
IBCG51M(-)Y1A	Inverse	Yes	6-150	0.5-4, 2-16	Fig. 6
IBCG53M(-)A	Very Inverse	No	-	0.5-4, 1.5-12	Fig. 5
IBCG54M(-)A	Very Inverse	No	-	0.5-4, 1.5-12	Fig. 7
IBCG53M(-)Y1A	Very Inverse	Yes	6-150	0.5-4, 1.5-12	Fig. 6
IBCG77M(-)A	Extremely Inverse	No	-	0.5-4, 1.5-12	Fig. 8
IBCG78M(-)A	Extremely Inverse	No	-	0.5-4, 1.5-12	Fig. 9

APPLICATION

The Type IBCG relays are ground directional overcurrent relays that may be used as ground fault detectors in a transmission line protective relaying scheme.

The relays contain a time overcurrent unit that is torque controlled by an instantaneous directional overcurrent unit. The directional unit may be polarized from a source of potential, or current, or both sources may be used to dual polarize the unit. It is advantageous to use dual polarization because changing system conditions may cause current polarization to be favored at some times whereas voltage polarization might be favored at others. Figure 13 illustrates the effect of using dual polarization as compared to polarization from a source of voltage or current alone.

The differences between the various models covered by this instruction book are shown in Table I. Inverse time relays should be used on systems where the fault current flowing through a given relay is influenced largely by the system generating capacity at the time of the fault. Very inverse time and extremely inverse time relays should be used in cases where the fault current magnitude is dependent mainly upon the location of the fault in relation to the relay, and only slightly or not at all upon the system generating setup. The reason for this is that relays must be set to be selective with maximum fault current flowing. For fault currents below this value, the operating time becomes greater as the current is decreased. If there is a wide range in generating capacity, together with variation in short-circuit-current with fault position, the operating time with minimum fault current may be exceedingly long with very inverse time relays and even longer with extremely inverse time relays. For such cases, the inverse time relay is more applicable.

The operating time of the time overcurrent unit for any given value of current and tap setting is determined by the time-dial setting. The operating time is inversely proportional to the current magnitude as illustrated by the time curves in Figures

15, 16 and 17. Note that the current values on these curves are given as multiples of the tap setting. That is, for a given time-dial setting, the time will be the same for 80 amperes on the 8 ampere tap as for 50 amperes on the 5 ampere tap, since in both cases the current is 10 times setting.

If selective action of two or more relays is required, determine the maximum possible short-circuit current of the line and then choose a time value for each relay that differs sufficiently to insure the proper sequence in the operation of the several circuit breakers. Allowance must be made for the time involved in opening each breaker after the relay contacts close.

The Y1A relays contain a Hi-Seismic instantaneous overcurrent unit. This unit may be set high to trip directly for faults some distance down the transmission line. In determining the setting for this unit, it will be necessary to consider faults directly behind the relay as well as at the remote terminal, because the unit is non-directional. The unit should be set with a suitable amount of margin above the maximum external fault current. The effects of transient overreach, as illustrated in Figure 19, should also be taken into account in determining the setting.

RATINGS

The IBCG relays described in this instruction are available in 50 and 60 hertz models. The TOC (time overcurrent) units have extended (8-to-1) range similar to the 800 series IAC relays. The IOC (instantaneous overcurrent) units, when used (see Table I), have extended (25-to-1) range. Ratings of the operating current circuits of the TOC, IOC and the directional units are shown individually. However, since all operating current circuits are normally connected in series, the operating coil ratings of all units should be considered in determining the rating of the entire operating circuit.

TABLE II
ONE SECOND RATING OF TOC UNITS

Relay Model	Range (Amps)	One Second Rating (Amps)
IBCG51M	0.5-4.0	70
IBCG51M(-)Y1A		
IBCG52M	2.0-16	260
IBCG53M	0.5-4.0	140
IBCG53M(-)Y1A		
IBCG54M	1.5-12	260
IBCG77M	0.5-4.0	125
IBCG78M	1.5-12	260

TIME OVERCURRENT UNIT

The 1 second ratings of the TOC units are given in Table II. The continuous ratings for the various taps of each model and current range are given in Tables III, IV and V.

TABLE III
CONTINUOUS RATING OF 0.5-4.0 AMP TOC UNITS

<u>0.5-4.0 Amp Range</u>												
Model	Tap	0.5	0.6	0.7	0.8	1.0	1.2	1.5	2.0	2.5	3.0	4.0
IBCG51M IBCG51M(-)Y1A IBCG52M	Rating (Amps)	1.6	1.8	2.0	2.1	2.3	2.7	3.0	3.5	4.0	4.5	5.0
IBCG53M IBCG53M(-)Y1A IBCG54M		4.0	4.5	5.5	5.5	6.0	7.0	7.5	9.0	10.0	11.0	13.0
IBCG77M IBCG78M		3.5	3.7	4.0	4.5	5.0	5.5	6.0	7.0	8.0	9.0	10.0

TABLE IV
CONTINUOUS RATING OF 1.5-12.0 AMP TOC UNITS

<u>1.5-12.0 Amp Range</u>												
Model	Tap	1.5	2.0	2.5	3.0	4.0	5.0	6.0	7.0	8.0	10.0	12.0
IBCG53M IBCG53M(-)Y1A IBCG54M	Rating (Amps)	10.0	11.5	13.0	14.5	17.0	19.0	21.0	23.0	23.5	27.5	30.5
IBCG77M IBCG78M		9.5	10.5	11.5	12.5	14.0	15.5	17.0	18.0	19.0	20.0	20.0

TABLE V

CONTINUOUS RATING OF 2-16.0 AMP TOC UNITS

<u>2-16.0 Amp Range</u>												
Model	Tap	2.0	2.5	3.0	4.0	5.0	6.0	7.0	8.0	10.0	12.0	16.0
IBCG51M IBCG51M(-)Y1A) IBCG52M	Rating (Amps)	8.0	9.0	10.0	12.0	14.0	15.0	16.0	17.5	20.0	20.0	20.0
IBCG77M IBCG78M		9.5	10.5	11.5	12.5	14.0	15.5	17.0	18.0	19.0	20.0	20.0

DIRECTIONAL UNIT

The directional unit current polarizing and operating coils have a continuous rating of 5 amperes and a 1 second rating of 150 amperes.

The potential polarizing coils will withstand 120 volts continuously and 360 volts for 60 seconds.

INSTANTANEOUS UNIT

The instantaneous unit coil is of the hinged armature construction and is tapped for operation on either one of two ranges (H or L). Selection of the high or low range is accomplished by the positioning of leads T and E at terminal 6. See Table VI and the applicable internal connections diagrams referred to in Table I. For the H range, connect lead T to terminal 6 and lead E to the auxiliary terminal that is mounted on terminal 6. For range L, reverse leads T and E.

TABLE VI

CONTINUOUS AND ONE SECOND RATINGS OF IOC UNIT

Instantaneous Unit (Amps)	Range	** Range (Amps)	Continuous Rating (Amps)	One Second Rating (Amps)
6-150	L	6 - 30	10.2	260
	H	30 - 150	19.6	

** The range is approximate, which means that 6-30, 30-150 may be 6-29, 28-150. There will always be at least 1 ampere overlap between the maximum L setting and the minimum H setting. Whenever possible, be sure to select the higher range, since it has the higher continuous rating.

TARGET AND SEAL-IN UNIT

The rating and impedance of the seal-in unit for the 0.2 and 2 ampere taps are given in Table VII. The tap setting used will depend on the current drawn by the trip coil.

TABLE VII

SEAL-IN UNIT RATINGS

	<u>TAP</u>	
	0.2	2.0
DC RESISTANCE +10% (OHMS)	8.3	0.24
MIN OPERATING (AMPERES) +0-25%	0.2	2.0
CARRY CONT. (AMPERES)	0.37	2.3
CARRY 30 AMPS FOR (SEC.)	0.05	2.2
CARRY 10 AMPS FOR (SEC.)	0.45	20
60 Hz IMPEDANCE (OHMS)	50.0	0.65

The 0.2 ampere tap is for use with trip coils which operate on currents ranging from 0.2 up to 2.0 amperes, at the minimum control voltage. If this tap is used with trip coils requiring more than 2 amperes, there is a possibility that the resistance of 7 ohms will reduce the current to so low a value that the breaker will not be tripped.

The 2.0 ampere tap should be used with trip coils that take 2 amperes or more at minimum control voltage, provided the current does not exceed 30 amperes at the maximum control voltage. If the tripping current exceeds 30 amperes, the connections should be arranged so that the induction unit contacts will operate an auxiliary relay, which in turn energizes the trip coil or coils. On such an application, it may be necessary to connect a loading resistor in parallel with the auxiliary relay coil to allow enough current to operate the target seal-in unit.

CONTACTS

The current-closing rating of the induction unit is 30 amperes for voltages not exceeding 250 volts. Their current-carrying rating is limited by the tap rating of the seal-in unit.

CHARACTERISTICS

PICKUP

When potential polarized, the directional unit will pick up at 3.6 volts-amperes at the maximum torque angle of 60° lag (current lags voltage). When current polarized, it will pick up at approximately 0.5 ampere with the operating and polarizing coils connected in series. The performance of the unit with simultaneous current and potential polarization is typified in Figure 13.

The current required to close the time overcurrent unit contacts will be within 5% of the tap screw setting.

RESET (TIME OVERCURRENT UNIT)

Inverse time overcurrent units reset at 90% of the minimum pickup current, very inverse time units at 80%, and extremely inverse time units at 85%.

When the relay is de-energized, the time required for the disk to completely reset to the number 10 time dial position is approximately 6 seconds for inverse time relays, and 60 seconds for very inverse time and extremely inverse time relays.

OPERATING TIME

The time curve for the directional unit is shown in Figure 14.

The time curves of the time overcurrent unit are shown in Figures 15, 16 and 17, respectively for inverse, very inverse and extremely inverse time relays. For the same operating conditions, the relay will operate repeatedly within 1 or 2% of the same time.

The time-current characteristic of the Hi-Seismic instantaneous unit is shown by Figure 18 and its transient overreach characteristic is shown by Figure 19.

BURDENS

The capacitive burden of the potential polarizing circuit of the directional unit at 60 cycles and 120 volts is 10 volt amperes at 0.86 power factor. Table VIII gives the current circuit burdens of the directional unit.

TABLE VIII

DIRECTIONAL UNIT CURRENT CIRCUIT BURDEN AT 60 CYLES AND 5 AMPERES

<u>Circuit</u>	<u>Z (Ohms)</u>	<u>VA</u>	<u>P.F</u>	<u>Watts</u>
Operating	0.46	12.0	0.52	6.24
Polarizing	0.24	6.0	0.95	5.27

Table IX gives the current circuit burdens of time overcurrent units.

Ordinarily the potential circuit is in the open corner of broken delta potential transformers and the current circuits are in the residual circuits of current transformers. The burden is, therefore, only imposed for the duration of the ground fault and need be considered only for this brief period. Table X gives the burden of the instantaneous unit.

TABLE IX

CURRENT CIRCUIT BURDENS AT 60 CYCLES OF THE TOC UNIT

Time Characteristic	Tap Range (Amps)	Burdens at Minimum Pickup			Ohms Impedance at			‡VA At Five Amperes	
		Eff. Res. (Ohms)	React. (Ohms)	**Imped (Ohms)	+Volt Amps	P.F.	3 Times Min P.U.		10 Times Min P.U.
Inverse	0.5/4	5.60	21.0	22.0	5.5	0.25	10.80	5.00	555.0
Inverse	2/16	0.37	1.44	1.49	5.8	0.25	0.65	0.32	36.3
Very Inverse	0.5/4	1.40	3.90	4.15	1.0	0.33	4.20	2.90	104.0
Very Inverse	1.5/12	0.23	0.53	0.58	1.3	0.40	0.58	0.36	14.5
Extr. Inverse	0.5/4	0.80	1.38	1.60	0.4	0.50	1.60	1.60	40.0
Extr. Inverse	1.5/12	0.005	0.147	0.17	0.4	0.50	0.17	0.17	4.25

**The impedance values given are those for the minimum tap of each relay. The impedance for other taps, at pickup current (tap rating), varies inversely approximately as the square of the current rating. Example: for the Type IBCG51M relay, 0.5/4 amperes, the impedance of the 0.5 ampere tap is 22 ohms. The impedance of the 1 ampere tap, at 1 ampere, is approximately $(0.5/1)^2 \times 22 = 5.5$ ohms.

+ Some companies list relay burdens only as the volt-ampere input to operate at minimum pickup. This column is included so a direct comparison can be made. It should not be used in calculating volt-ampere burdens in a CT secondary circuit, since the burden at 5 amperes is used for this purpose.

‡ Calculated from burden at minimum pickup.

TABLE X

BURDEN OF THE INSTANTANEOUS UNIT

Inst. Unit Amps	Hz	Range	Range Amps	Min. Pickup Amps	Burden at Min Pickup (Ohms)			Burden Ohms (Z) Times Pickup		
					R	J _x	Z	3	10	20
6-150	60	L	6-30	6	0.110	0.078	0.135	0.095	0.081	0.079
			30-150	30	0.022	0.005	0.023	0.022	0.022	0.222

CONSTRUCTION

The IBCG relays consist of two units, a time overcurrent unit (top) of the induction disk type, and an instantaneous power directional unit (bottom) of the induction cup type. The directional unit is either potential or current polarized or both and, by means of its closing contacts, directionally controls the operation of the time overcurrent unit.

The IBCG relays have a target seal-in unit and models with the Y1A suffix, as shown by Table I, have a hinged-armature type instantaneous overcurrent unit.

The IBCG relays are mounted in the single-ended M1 drawout case.

DIRECTIONAL UNIT

The directional unit is of the induction-cylinder construction with a laminated stator having eight poles projecting inward and arranged symmetrically around a stationary central core. The cuplike aluminum induction rotor is free to operate in the annular air gap between the poles and the core. The poles are fitted with current-operating, current-polarizing and potential-polarizing coils.

The principle by which torque is developed is the same as that of an induction disk relay with a wattmetric element, although, in arrangement of parts, the unit is more like a split-phase induction motor. The induction-cylinder construction provides higher torque and lower rotor inertia than the induction-disk construction, resulting in a faster and more sensitive unit.

CONTACTS

The directional unit contacts that control the time overcurrent unit are shown in Figure 20. They are of the low gradient type, specially constructed to minimize the effects of vibration. Both the stationary and moving contact brushes are made of low gradient material which, when subjected to vibration, tend to follow one another, hence, they resist contact separation.

The contact dial (A) supports the stationary contact brush (B) on which is mounted a conical contact tip (C). The moving contact arm (D) supports the moving contact brush (E) on which is mounted a button contact tip (F). The end of the moving contact brush bears against the inner face of the moving contact brush retainer (G). Similarly, the end of the stationary contact brush bears against the inner face of the stationary contact brush retainer (H). The stop screw (J), mounted on the contact dial, functions to stop the motion of the contact arm by striking the moving contact brush retainer after the moving and stationary contact members have made contact. The stationary contact support (K) and the contact dial are assembled together by means of a mounting screw (L) and two locknuts (M).

TIME OVERCURRENT UNIT

The inverse time and very inverse time overcurrent units consist of a tapped current-operating coil wound on a U-magnet iron structure. The tapped operating coil is connected to taps on the tap block. The U-magnet contains wound shading coils which are connected in series with a directional unit contact. When power flow is in such a direction as to close the directional unit contacts, the shading coils act to produce a split-phase field which, in turn, develops torque on the operating disk.

The extremely inverse time overcurrent unit is of the wattmetric type similar to that used in watt-hour meters except as follows: the upper portion of the iron structure has two concentric windings on the middle leg of the magnetic circuit. One of these is a tapped current winding connected to taps on the tap block; the other is a floating winding which is connected in series with the directional unit contacts, a resistor, a capacitor and the two coils on the lower legs of the magnetic circuit. When power flow is in such a direction as to close a directional unit contact, the unit develops torque on the operating disk.

The disk shaft carries the moving contact which completes the trip circuit when it touches the stationary contact or contacts. The shaft is restrained by a spiral spring to give the proper contact-closing current, and its motion is retarded by a permanent magnet acting on the disk to produce the desired time characteristic. The variable retarding force resulting from the gradient of the spiral spring is compensated by the spiral shape of the induction disk, which results in an increased driving force as the spring winds up.

TARGET SEAL-IN UNIT

A seal-in unit is mounted on the left side of the time overcurrent unit. This unit has its coil in series and its contacts in parallel with the main contacts of the overcurrent unit, arranged in such a manner that when the main contacts close, the seal-in unit picks up and seals-in around the main contacts. When the seal-in unit operates, it raises a target into view which latches up and remains exposed until manually released by pressing the button located at the lower left corner of the cover.

INSTANTANEOUS UNIT

The IOC unit is a small hinged-armature-type instantaneous element and is mounted on the right side of the TOC unit. The IOC element operates over a 25-to-1 total range obtained by using a tapped coil which provides a 5-to-1 low range and a 5-to-1 high range; this combination provides the 25-to-1 total range. When the current reaches a predetermined value, the instantaneous element operates, closing its contact circuit and raising its target into view. The target latches in the exposed position until it is released. The same button that releases the target seal-in unit also releases the target of the instantaneous unit.

RECEIVING, HANDLING AND STORAGE

These relays, when not included as part of a control panel, will be shipped in cartons designed to protect them against damage. Immediately upon receipt of a relay, examine it for any damage sustained in transit. If injury or damage resulting from rough handling is evident, file a damage claim at once with the transportation company and promptly notify the nearest General Electric Sales Office.

Reasonable care should be exercised in unpacking the relay in order that none of the parts are injured or the adjustments disturbed.

If the relays are not to be installed immediately, they should be stored in their original cartons in a place that is free from moisture, dust and metallic chips. Foreign matter collected on the outside of the case may find its way inside when the cover is removed, and cause trouble in the operation of the relay.

ACCEPTANCE TESTS

Immediately upon receipt of the relay an INSPECTION AND ACCEPTANCE TEST should be made to ensure that no damage has been sustained in shipment and that the relay calibrations have not been disturbed. If the examination or the test indicates that readjustment is necessary, refer to the section on SERVICING.

Since operating companies use different procedures for acceptance and installation tests, the following section includes all applicable tests that may be performed on these relays. These tests may be performed as part of the installation or acceptance tests, at the discretion of the user.

VISUAL INSPECTION

Check the nameplate stamping to ensure that the model number and rating of the relay agree with the requisition.

Remove the relay from its case and check that there are no broken or cracked molded parts or other signs of physical damage and that all screws are tight. Check that the shorting bars are in the proper location(s) as shown by the internal connections diagrams, Figures 5 to 9, inclusive, and that the main brush is properly formed to contact the shorting bar.

MECHANICAL INSPECTIONTop Unit (TOC)

1. The disk shaft end play should be 0.005-0.015 inch.
2. The disk should be centered in the air gaps of both the electromagnet and drag magnet.
3. Both air gaps should be free of foreign matter.
4. The disk should rotate freely and should return by itself to the reset position.
5. The moving contact should just touch the stationary contact when the time dial is at the 0 time dial position.

Bottom Unit (DIR)

1. The rotating shaft end play should be 0.015-0.020 inch.
2. The contact gap should be 0.015-0.025 inch on the low gradient contact.

Target and Seal-in Unit/Instantaneous Unit

1. The armature and contacts should move freely when operated by hand.
2. Both contacts should make at approximately the same time.
3. The target should latch into view just as the contacts make and should unlatch when the target release button is operated.
4. The contacts should have approximately 0.030 inch wipe.

DRAWOUT RELAYS, GENERAL

Since all drawout relays in service operate in their cases, it is recommended that they be tested in their cases or an equivalent steel case. In this way, any magnetic effects of the enclosure will be accurately duplicated during testing. A relay may be tested without removing it from the panel by using a 12XLA13A test plug. This plug makes connections only with the relay and does not disturb any shorting bars in the case. The 12XLA12A test plug may also be used. Although this test plug allows greater testing flexibility, it requires CT shorting jumpers and the exercise of greater care, since connections are made to both the relay and the external circuitry.

POWER REQUIREMENTS, GENERAL

All alternating-current-operated devices are affected by frequency. Since non-sinusoidal waveforms can be analyzed as a fundamental frequency plus harmonics of the fundamental frequency, it follows that alternating-current (AC) devices (relays) will be affected by the applied waveform.

Therefore, in order to test alternating current relays properly, it is essential to use a sine wave of current and/or voltage. The purity of the sine wave (i.e., its freedom from harmonics) cannot be expressed as a finite number for any particular relay; however, any relay using tuned circuits, R-L or RC networks, or saturating electromagnets (such as time overcurrent relays) is affected by non-sinusoidal waveforms.

TARGET AND SEAL-IN UNIT

The target and seal-in unit has an operating coil tapped at 0.2 and 2.0 amperes.

When used with trip coils operating on currents ranging from 0.2 to 2.0 amperes at the minimum control voltage, the target and seal-in tap screw should be set in the 0.2 ampere tap. When the trip coil current ranges from 2 to 30 amperes at the minimum control voltage, the tap screw should be placed in the 2.0 ampere tap.

The seal-in tap screw is the screw holding the right-hand stationary contact of the seal-in unit. To change the tap setting, first remove the connecting plug. Then take a screw from the left-hand stationary contact and place it in the desired tap. There will now be screws in both taps. Next, remove the screw from the other (undesired) tap and place it back in the left-hand contact. This procedure is necessary to prevent the right-hand stationary contact from getting out of adjustment. **Tap screws should never be allowed to remain in both taps at the same time.**

Pickup and Dropout Test

1. Connect relay studs 1 and 2 (see internal connections diagram) to a DC source, ammeter and load box so that the current can be controlled over a range of 0.1 to 2.0 amperes.
2. Close or jumper the contact(s) that parallel the seal-in unit contact.
3. Increase the current slowly until the seal-in unit picks up. See Table XI.
4. Open the parallel contact circuit of step 2; the seal-in unit should remain in the picked up position.
5. Decrease the current slowly until the seal-in unit drops out. See Table XI.

TABLE XI

TARGET AND SEAL-IN UNIT OPERATING CURRENTS

TAP	PICKUP CURRENT	DROPOUT CURRENT
0.2	0.115 - 0.195	0.05 OR MORE
2.0	1.15 - 1.95	0.55 OR MORE

TIME OVERCURRENT UNIT

Rotate the time dial slowly and check by means of a lamp that the contacts just close at the 0 time-dial setting.

Where the contacts just close can be adjusted by running the stationary contact brush in or out by means of its adjusting screw. This screw should be held securely in its support.

With the contacts just closing at No. 0 time-dial setting, there should be sufficient gap between the stationary contact brush and its metal backing strip to ensure approximately 1/32 inch wiper.

Current Setting

The minimum current at which the time overcurrent unit will close its contacts is determined by the position of the plug in the tap block. The tap plate on this block is marked in amperes, as shown in Tables III, IV and V.

When the tap setting is changed with the relay energized in its case, the following procedure must be followed: (1) Remove the connecting plug; this de-energizes the relay and shorts the current transformer secondary winding. (2) Remove the tap screw and place it in the tap marked for the desired pickup current. (3) Replace the connecting plug.

The minimum current required to rotate the disk slowly and to close the contacts should be within 5% of the value marked on the tap plate for any tap setting and time dial position. If this adjustment has been disturbed, it can be restored by means of the spring adjusting ring. The ring can be turned by inserting a screw driver blade in the notches around the edge. By turning the ring, the operating current of the unit can be brought into agreement with the tap setting employed. This adjustment also permits any desired setting to be obtained intermediately between the available tap settings.

Pickup adjustment by means of the control spring applies to the IBCG51/52 and IBCG53/54 relays. A different procedure applies to the IBCG77/78 relays. For the IBCG77/78 relays, the pickup of the unit for any current tap setting is adjusted by means of the variable resistor in the phase-shifting circuit. This adjustment also permits any desired setting intermediate between the various tap settings to be obtained. The control spring is prewound approximately 660° with the contacts just closed. Further adjustment of this setting is seldom required; if it is required,

because of the insufficient range of the variable resistor, it should never be necessary to wind up the control spring adjuster more than 30° (1 notch) or unwind it more than 90° (3 notches) from the factory setting.

Test connections for making pickup and time checks on the time over-current unit are shown in Figures 22 and 23. Use a source of 120 volts or greater with good wave form and constant frequency. Stepdown transformers or phantom loads should not be employed in testing induction relays since their use may cause a distorted wave form. The contact in the wound shading coil circuit marked D, see internal connection diagram, must be blocked closed or jumpered for both the pickup test and the time test.

Time Setting

The setting of the time dial determines the length of time the unit requires to close its contacts when the current reaches a predetermined value. The contacts are just closed when the dial is set on 0. When the dial is set on 10, the disk must travel the maximum amount to close the contacts and therefore this setting gives the maximum time setting.

The primary adjustment for the time of operation of the unit is made by means of the time dial. However, further adjustment is obtained by moving the permanent magnet along its supporting shelf; moving the magnet toward the disk shaft decreases the time, while moving it away increases the time. Be sure the magnet never extends out beyond the cutout in the disk.

Pickup Test

Use rated frequency for both the pickup and time tests. The directional unit contact must be closed to perform the pickup and time tests.

Set the relay at the 0.5 time-dial position and 2.0 ampere tap. Using the test connection in Figure 22, the main unit should close its contacts within $\pm 2.0\%$ of tap value current (1.96-2.04 amps).

Time Test

Set the relay at No. 5 time-dial setting and the 2.0 amp tap. Using the test connection in Figure 23, apply 5 times tap current (10.0 amp) to the relay. The relay should operate within the limits given in Table XII.

TABLE XII

TOC UNIT OPERATING TIME LIMITS

Relay Type	<u>Time in Seconds</u>		
	Min.	Midpoint	Max
IBCG51-IBCG52	1.72	1.78	1.83
IBCG53-IBCG54	1.27	1.31	1.35
IBCG77-IBCG78	0.89	0.92	0.95

DIRECTIONAL UNIT

Current Polarization

- a. Connect per Figure 24 test connections.
- b. The unit should close its contacts within 5% of 0.5 ampere. The clutch should slip between 8-18 amperes.

CAUTION
This level of current can overheat the coil if applied too frequently or for too long a period of time.

Potential Polarization

- a. Connect per Figure 25 test connections.
- b. With V set for 5 volts at terminals 9 to 10, the unit should close its contacts between 0.75-1.75 amps.

INSTANTANEOUS UNIT

Make sure that the instantaneous unit is in the correct range in which it is to operate. See the internal connections diagram and Table VI.

Whenever possible, use the higher range since the higher range has a higher continuous rating.

The instantaneous unit has an adjustable core located at the top of the unit. To set the instantaneous unit to a desired pickup, loosen the locknut and adjust the core. Turning the core clockwise decreases the pickup; turning the core counterclockwise increases the pickup. Bring up the current slowly until the unit picks up. It may be necessary to repeat this operation, until the desired pickup value is obtained. Once the desired pickup value is reached, tighten the locknut.

CAUTION
Refer to Table VI (p.7) for the continuous and 1 second ratings of the instantaneous unit. Do not exceed these ratings when applying current to the instantaneous unit.

The range of the instantaneous unit (see Table VI) must be obtained between a core position of 1/8 of a turn of "full clockwise", and 20 turns counterclockwise from the full-clockwise position.

LOCATION

INSTALLATION

The location should be clean and dry, free from dust and excessive vibration and well lighted to facilitate inspection and testing.

MOUNTING

The relay should be mounted on a vertical surface. The outline and panel drilling diagram is shown in Figure 26.

CONNECTIONS

The internal connection diagrams for the various relays are shown in Figures 5 to 9. Typical external wiring diagrams are shown by Figures 10, 11 and 12.

Unless mounted on a steel panel which adequately grounds the relay case, it is recommended that the case be grounded through a mounting stud or screw with a conductor not less than #12 B&S gage copper wire or its equivalent.

INSPECTION

At the time of installation, the relay should be inspected for tarnished contacts, loose screws, or other imperfections. If any trouble is found, it should be corrected in the manner described in the section on SERVICING.

CAUTION

Every circuit in the drawout case has an auxiliary brush. It is especially important on current circuits and other circuits with shorting bars that the auxiliary brush be bent high enough to engage the connecting plug or test plug before the main brushes do. This will prevent CT secondary circuits from being opened. Refer to Figure 21.

OPERATION

Before the relay is put into service, it should be given a check to determine that factory adjustments have not been disturbed. The time dial will be set at 0 before the relay leaves the factory. If the setting has not been changed, it will be necessary to change this setting in order to open the time overcurrent unit contacts. The following tests are suggested:

TARGET AND SEAL-IN UNIT

1. Make sure that the tap screw is in the desired tap.
2. Perform pickup and dropout tests as outlined in the ACCEPTANCE TEST section.

TIME OVERCURRENT UNIT

1. Set tap screw on desired tap. Using the test circuit in Figure 22, apply approximately twice tap value current until the contacts just close. Reduce the current until the light in series with the contacts begins to flicker. This value of current should be within 5% of tap value.
2. Check the operating time at some multiple of tap value. This multiple of tap value may be 5 times tap rating or the maximum fault current for which the relay must coordinate. The value used is left to the discretion of the user. Use the test circuit shown in Figure 23.

DIRECTIONAL UNIT

Current Polarization

- a. Connect per Figure 24 test connections.
- b. Adjust the control spring for 0.5 ampere pickup if current polarized or dual polarized.

Potential Polarization

- c. If potential polarized, connect per Figure 25 test connections.
- d. Adjust the control spring for 7.2 volt amperes ($\pm 10\%$) since the relay is 60° from the angle of maximum torque. 10 volts and 0.72 amperes are recommended values for this test.

INSTANTANEOUS UNIT

1. Select the desired range by making the proper connections at the rear of the relay (see internal connections diagram). Whenever possible, be sure to select the higher range since it has a higher continuous rating.
2. Set the instantaneous unit to pick up at the desired current level. See the ACCEPTANCE TEST section.

PERIODIC CHECKS AND ROUTINE MAINTENANCE

In view of the vital role of protective relays in the operation of a power system, it is important that a periodic test program be followed. It is recognized that the interval between periodic checks will vary depending upon environment, type of relay and the user's experience with periodic testing. Until the user has accumulated enough experience to select the test interval best suited to his individual requirements, it is suggested that the points listed below be checked at an interval of from one to two years.

These tests are intended to ensure that the relays have not deviated from their original settings. If deviations are encountered, the relay must be retested and serviced as described in this manual.

TARGET AND SEAL-IN UNIT

1. Check that the unit picks up at the values shown in Table X.
2. Check that the unit drops out at 25% or more of tap value.

TIME OVERCURRENT UNIT

1. Perform pickup test for the tap in service, as described in the OPERATION section.
2. Perform the time tests as described in the OPERATION section.

DIRECTIONAL UNIT

Repeat the portion of the ACCEPTANCE TEST for the polarity condition for which the relay is connected in service.

INSTANTANEOUS UNIT

Check that the instantaneous unit picks up at the desired current level, as outlined in the **ACCEPTANCE TESTS** and the **OPERATION** sections.

SERVICING

These relays are adjusted at the factory and it is advisable not to disturb the adjustments. If, for any reason, they have been disturbed or it is found during installation or periodic testing that the relay is out of limits, the checks and adjustments outlined in the following paragraphs should be observed. It is suggested that this work be done in the laboratory.

TARGET AND SEAL-IN UNIT

Repeat the visual and mechanical inspections and the pickup and dropout current checks as outlined in the **ACCEPTANCE TESTS** section.

TIME OVERCURRENT UNIT

Disk and Bearings

The jewel should be turned up until the disk is centered in the air gaps, after which it should be locked in this position by the set screw provided for this purpose. The upper bearing pin should next be adjusted so that the disk shaft has about 1/64 inch end play.

Contact Adjustment

The contacts should have about 1/32 inch wipe. That is, the stationary contact tip should be deflected about 1/32 inch when the disk completes its travel. Wipe is adjusted by turning the wipe adjustment screw on the stationary contact, thereby adjusting the position of the brush relative to the brush stop.

When the time dial is moved to the position where it holds the contacts just closed, it should indicate 0 on the time-dial scale. If it does not and the brushes are correctly adjusted, shift the dial by changing the position of the arm attached to the shaft just below the time dial. Loosen the screw clamping the arm to the shaft and turn the arm relative to the shaft until the contacts just make for 0 zero time-dial setting.

Characteristics Check and Adjustments

Repeat the portions of the **ACCEPTANCE TESTS** section that apply to the time overcurrent unit. Also, check reset voltage and time as outlined under **RESET** in the **CHARACTERISTICS** section; low reset voltages or long reset times may indicate excessive friction caused by a worn bearing or by mechanical interference.

On IBCG77/78 relays, set the relay on the 2 amp tap with the time dial set so that the contacts are just open. Adjust pickup within the limits 1.96 to 2.04 amps, but as close as possible to 2.0 amps. Then move the time dial to the No. 10 position and check the current required to just move the disk away from the stop arm. This current should be within the limits 1.88 to 2.12 amps. If the disk moves at the lower limit, check that movement is not over 1/2 inch, measured along the periphery of the disk. This is called a compensation check. If the current falls outside the 1.88 to 2.12 amp limits, the following steps should be taken: reset the control spring until compensation at No. 10 time dial is within limits. Then restore pickup by adjusting the resistor. Recheck compensation after the resistor adjustment.

DIRECTIONAL UNIT

Bearings

The lower jewel bearing should be screwed all the way in until its head engages the end of the threaded core support. The upper bearing should be adjusted to allow about 1/64 inch end play in the shaft.

To check the clearance between the iron core and the inside of the rotor cup, press down on the contact arm near the shaft, thus depressing the spring-mounted jewel until the cup strikes the iron. The shaft should move about 1/16 inch.

Cup and Stator

Should it be necessary to remove the cup-type rotor from the directional unit, the following procedure should be followed:

All leads to the unit should first be disconnected and tagged for identification in reconnecting. The unit can then be removed from the cradle with its mounting plate still attached.

The upper of the three flat-head screws holding the unit to the plate should now be removed. On some models, it may be necessary to remove a resistor or capacitor to expose this screw. The four corner screws clamping the unit together should next be removed, and the entire top structure lifted off. This gives access to the cup assembly and exposes the stator assembly, which should be protected to keep it from dust and metallic particles until the unit is reassembled.

To remove the shaft and rotor from the contact head assembly, the spring clip at the top of the shaft must be pulled out and the clutch adjusting screw taken out of the side of the molded contact arm. The shaft and cup can now be pulled out of the molding. The rotor must be handled very carefully while it is out of the unit.

Contact Adjustments

To make contact adjustments, refer to Figure 20 for identification of low gradient contact parts and proceed as follows:

Loosen the locknut which secures the moving contact stop (backstop) screw (located at the front right hand corner of the directional unit) to its support. Unwind the backstop screw so that the moving contact arm is permitted to swing freely. Adjust the tension of each low gradient contact brush so that 1-to-2 grams of pressure are required at the contact tip in order to cause the end of the brush to separate from the inner face of its respective brush retainer. Adjust the spiral spring with the windup sprocket until the moving contact arm is in a neutral position, i.e., with the arm pointing directly forward. Loosen the locknut which secures the stationary contact mounting screw to the stationary contact support. Wind the mounting screw inward until the stationary and moving contact members just begin to touch. Unwind the mounting screw until the stationary contact stop lines up with the moving contact brush retainer. Wind the backstop screw inward until the moving and stationary contact members again just begin to touch. Loosen the locknut of the stationary contact stop screw, and advance this screw until it just touches the moving contact brush retainer. Unwind the screw 1 and a half turns to provide contact wipe. Tighten the locknut. Unwind the backstop screw 2/3 turn and tighten the locknut which secures the backstop screw to its support. Finally, adjust the tension on the stationary contact brush such that, when the contacts are made and fully wiped in, there is approximately an equal deflection on each brush.

Bias Torque Adjustment

Connect the current operating and current polarizing coils in series by connecting a jumper across terminals 5 and 8. Apply current to terminals 4 and 7 and adjust the directional unit spiral spring so that the unit picks up at 0.5 ampere with terminals 9 and 10 jumpered.

The core of the directional unit has a small flat portion, the purpose of which is to minimize the effect of bias torques produced on the rotor. Such torques can be produced by any one of the operating or polarizing quantities acting alone with the other two circuits de-energized. The adjustment of the core is made at the factory, but may be checked by observing that the unit responds as outlined below:

Short out the potential polarizing coil (terminals 9 and 10), leaving the current polarizing coil (terminals 7 and 8) unshorted. Supply 30 amperes through the operating coil (terminals 4 and 5) and check that the unit does not operate.

If the unit does not satisfy the above conditions, rotate the core to a position which causes it to do so. The core can be turned by loosening the large hexagonal nut on the underside of the relay and turning the core by means of the slotted bearing screw. This screw should be held securely in position when the nut is retightened.

Keep in mind that 30 amperes will cause the current coils to overheat if left on too long. Therefore, leave the test current on only for short intervals and allow sufficient time between tests for the coils to cool.

Clutch Adjustment

The connections shown in Figure 24 for the polarity check can also be used in making the clutch adjustment. The fixed resistor should be capable of controlling the current in the range of 5 to 25 amperes. A screw projecting from the side of the

moving contact arm controls the clutch pressure. Use rated frequency and current in phase with the voltage. Adjust the clutch so that it will not slip at 10 amperes or less of suddenly applied current, but will slip at or above 15 amperes. This setting, 10-15 amperes, is tighter than the 8-18 ampere acceptance test limit and is intended to assure that the acceptance test limits will be met in any future tests.

INSTANTANEOUS UNIT

1. Both contacts should close at the same time.
2. The backing strip should be so formed that the forked end (front) bears against the molded strip under the armature.
3. With the armature against the pole piece, the cross member of the "T" spring should be in a horizontal plane and there should be at least 1/64 inch wiper on the contacts. Check this by inserting a 0.010 inch feeler gage between the front half of the shaded pole and the armature with the armature held closed. The contacts should close with the feeler gage in place.

Contact Cleaning

For cleaning fine silver contacts, a flexible burnishing tool should be used. This consists of a flexible strip of metal with an etched roughened surface, resembling in effect a superfine file. The polishing action is so delicate that no scratches are left, yet corroded material will be removed rapidly and thoroughly. The flexibility of the tool ensures the cleaning of the actual points of contact.

Fine silver contacts should not be cleaned with knives, files or abrasive paper or cloth. Knives or files may leave scratches which increase arcing and deterioration of the contacts. Abrasive paper or cloth may leave minute particles of insulating abrasive material in the contacts, thus preventing contact closing.

The burnishing tool described above can be obtained from the factory.

RENEWAL PARTS

It is recommended that sufficient quantities of renewal parts be carried in stock to enable the prompt replacement of any that are worn, broken or damaged.

When ordering renewal parts, address the nearest Sales Office of the General Electric Company, specify quantity required, name of part wanted, and give complete nameplate data. If possible, give the General Electric Company requisition number on which the relay was furnished. Refer to renewal parts publication GEF-4083.

Since the last edition, Figure 26 has been changed.

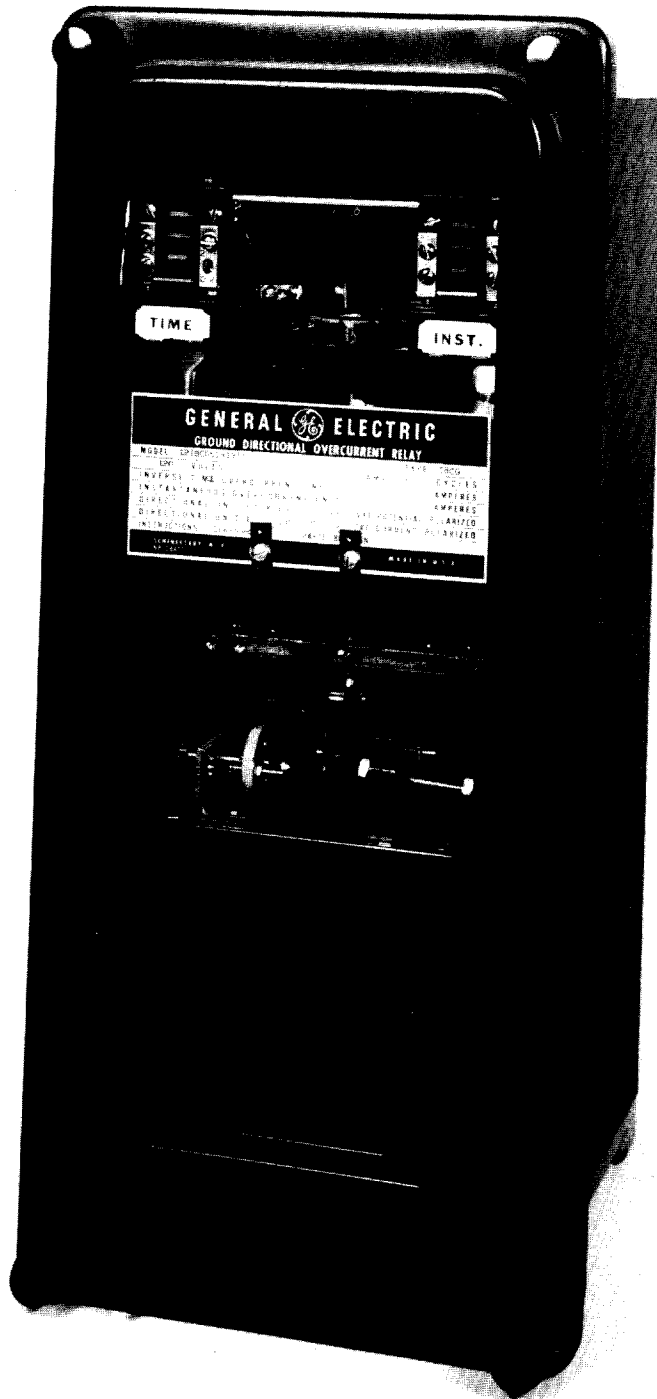

Figure 1 (8043458) Type IBCG51M(-)Y1A or the IBCG53M(-)Y1A Relay in its Case (Front View)

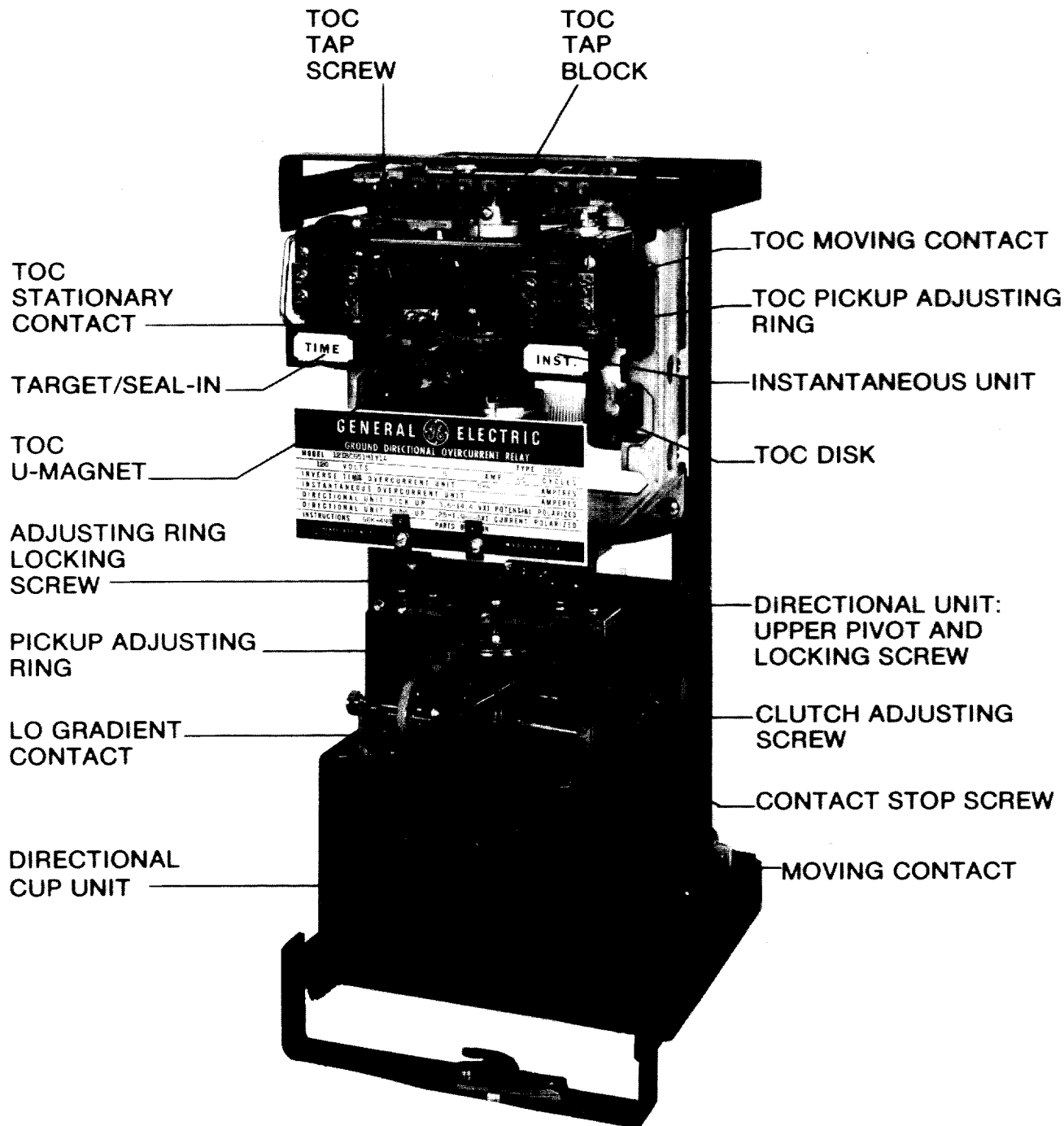

Figure 2 (8043459) Type IBCG51M(-)Y1A or the IBCG53M(-)Y1A Relay
Removed from Case (Front View)

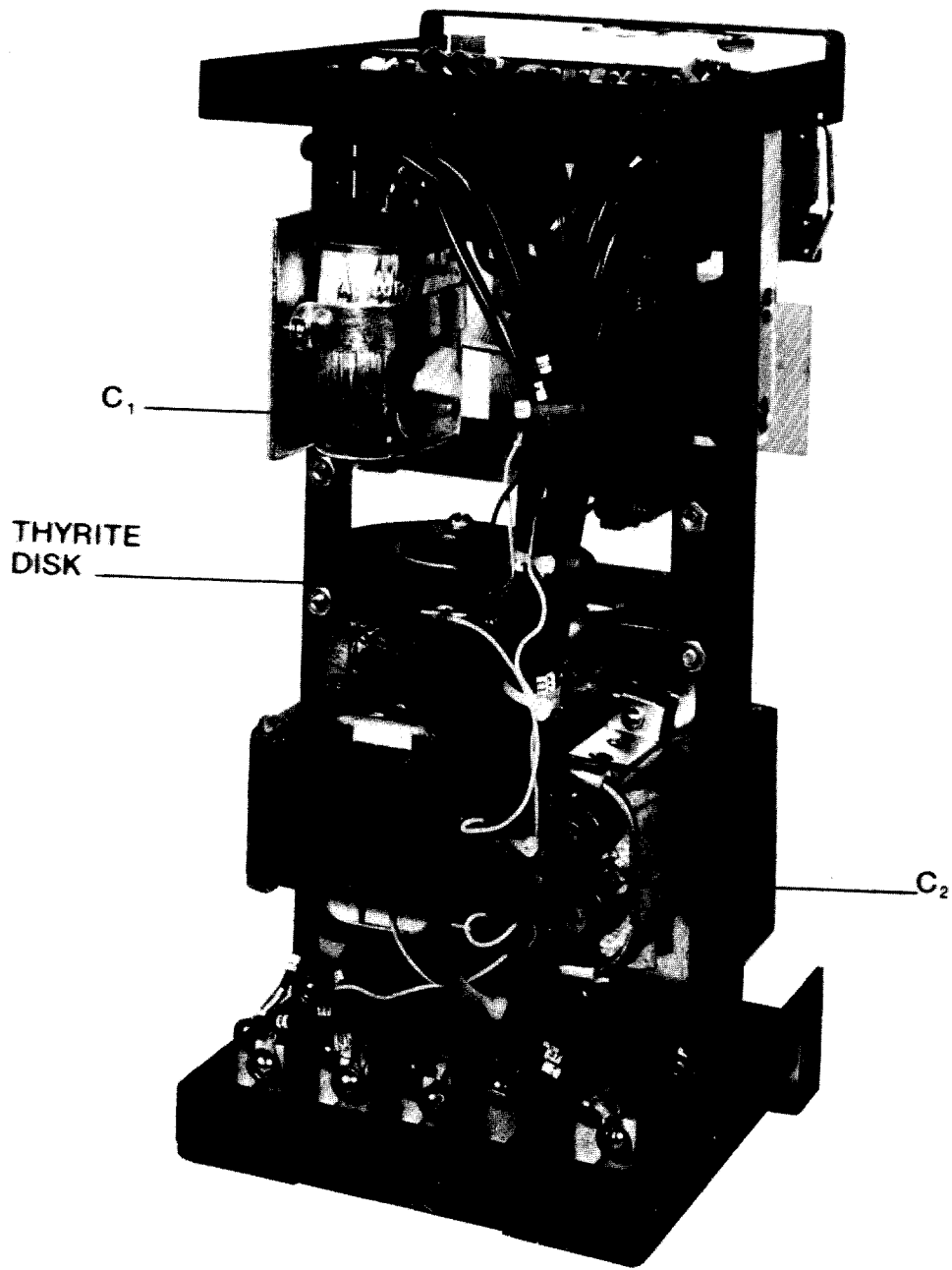

Figure 3 (8043460) Type IBCG51M(-)Y1A or the IBCG53M(-)Y1A Relay
Removed from Case (Rear View)

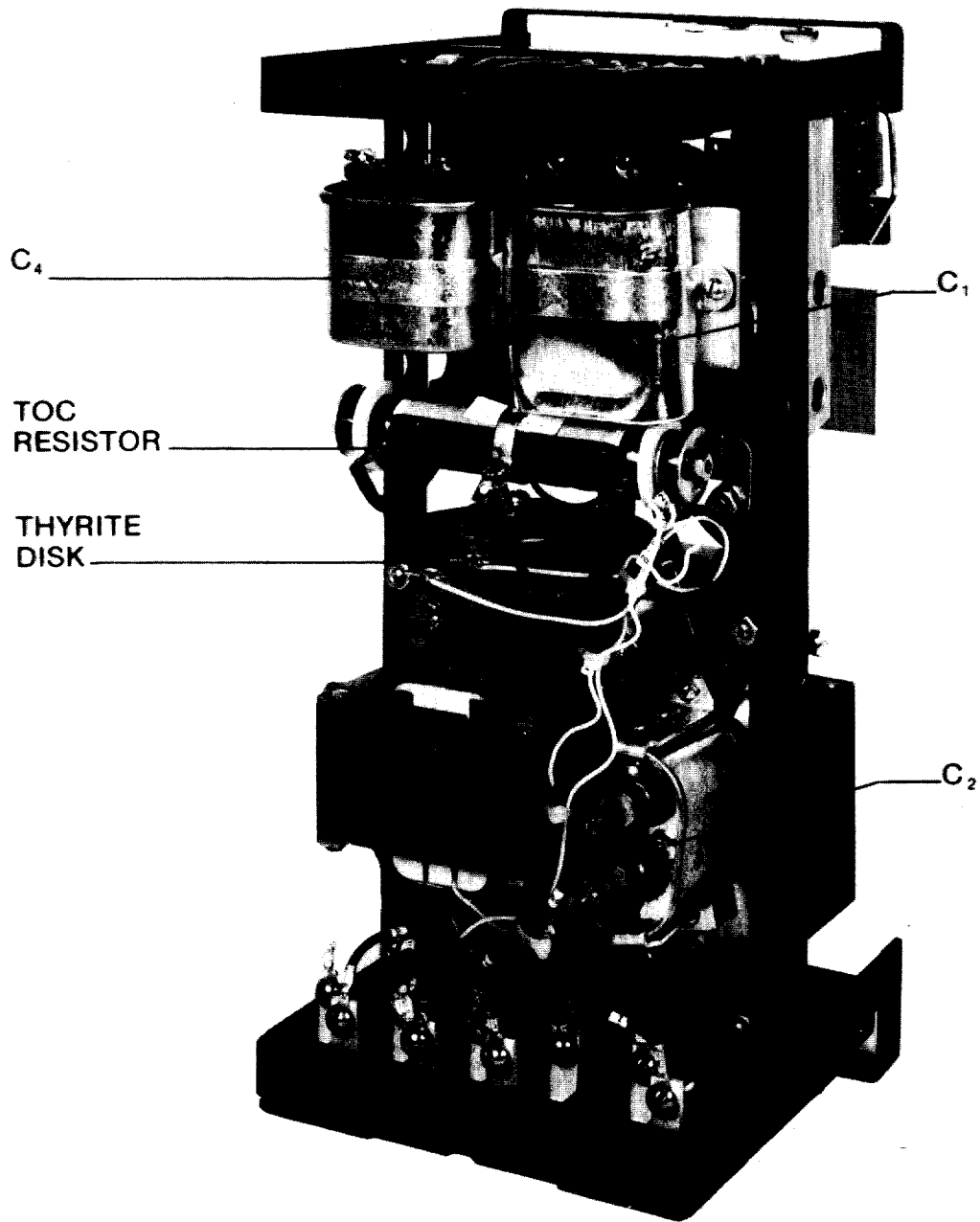

Figure 4 (8043461) Type IBCG77M or IBCG78M Relay Removed from Case (Rear View)

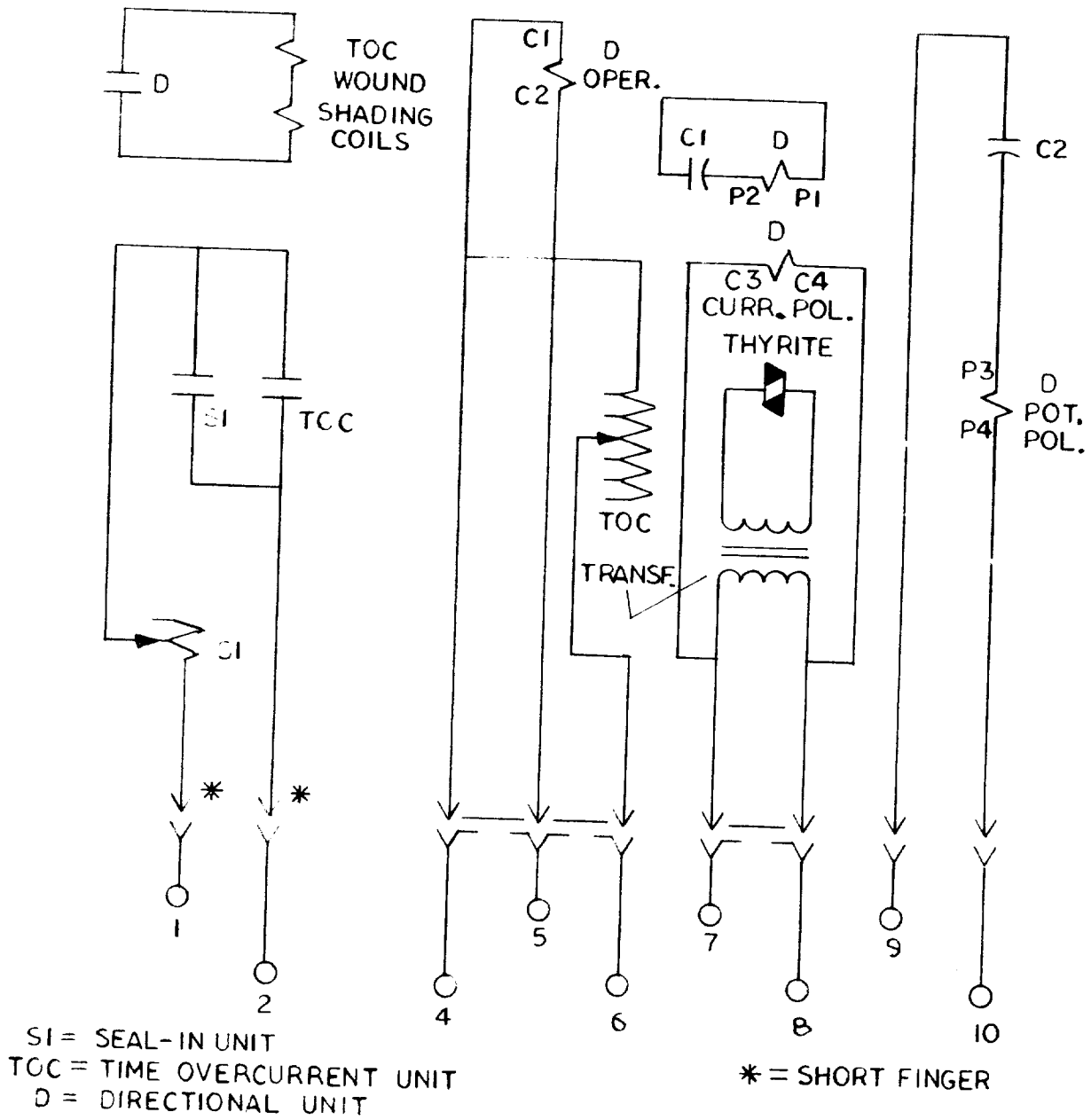

Figure 5 (0269A3061-0) Internal Connections for IBCG51M and IBCG53M Relays (Front View)

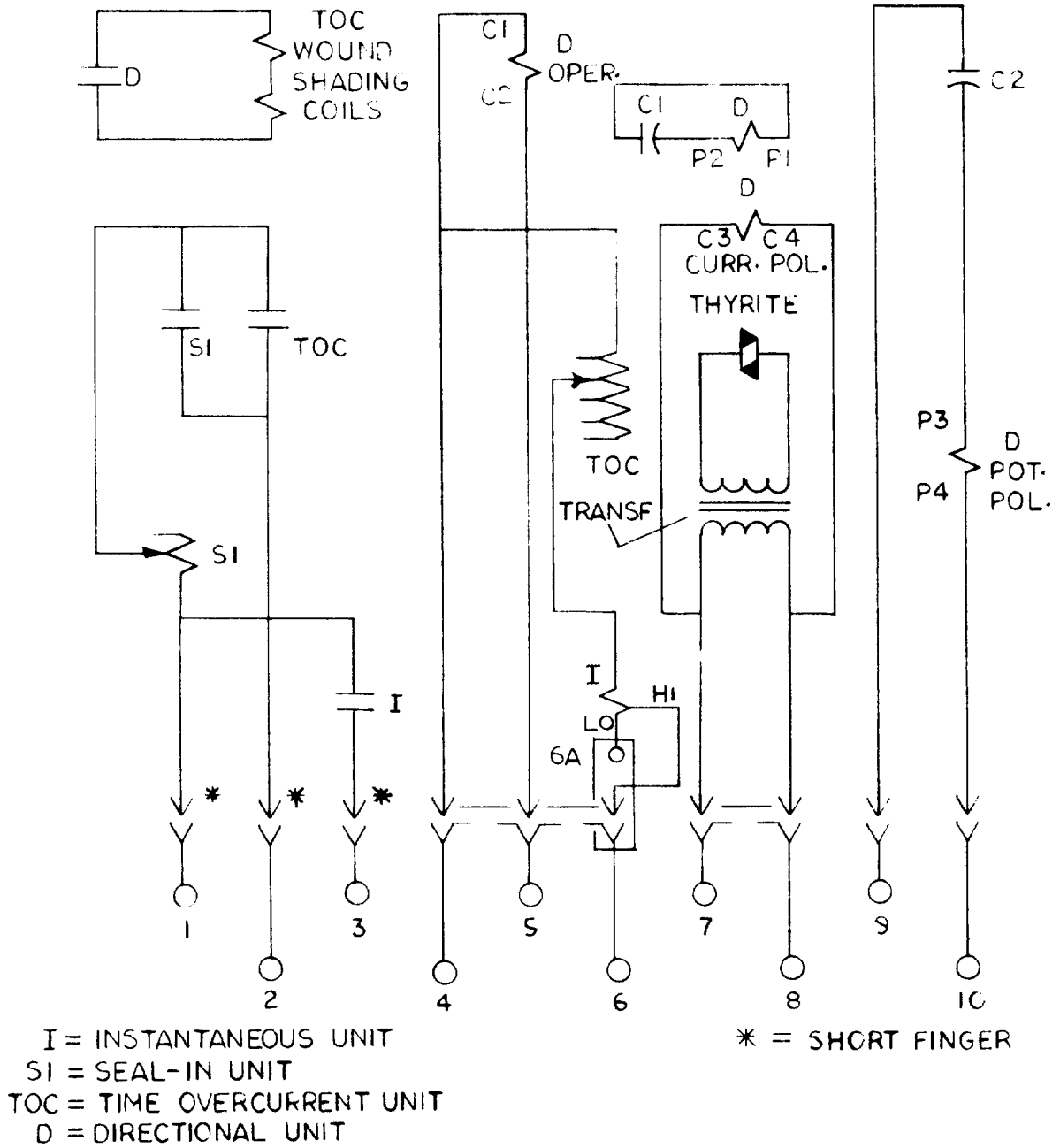

Figure 6 (0269A3062-0) Internal Connections for IBCG51M(-)Y1A and IBCG53M(-)Y1A Relays (Front View)

dial

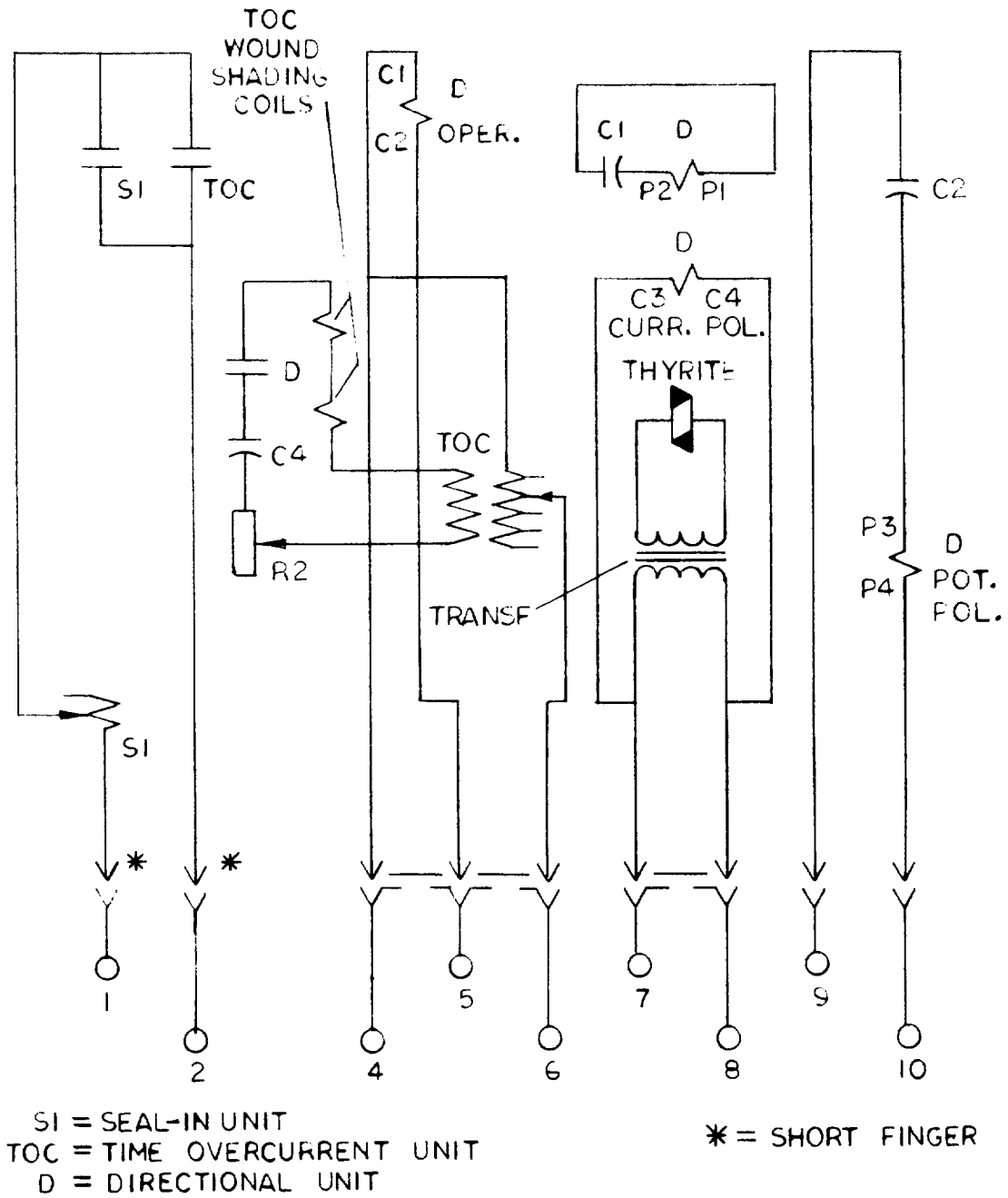

Figure 8 (0269A3063-0) Internal Connections for IBCG77M Relay (Front View)

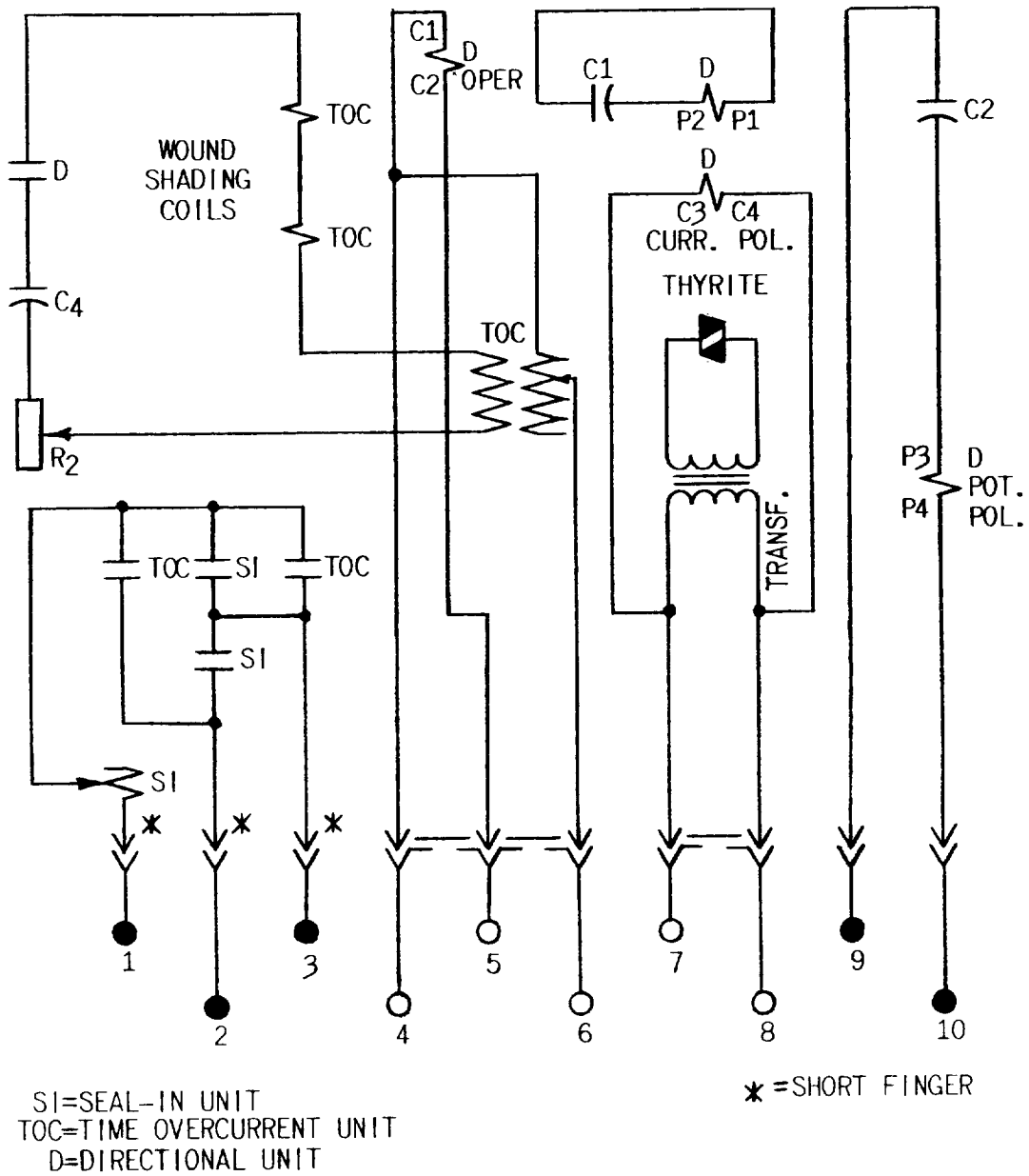
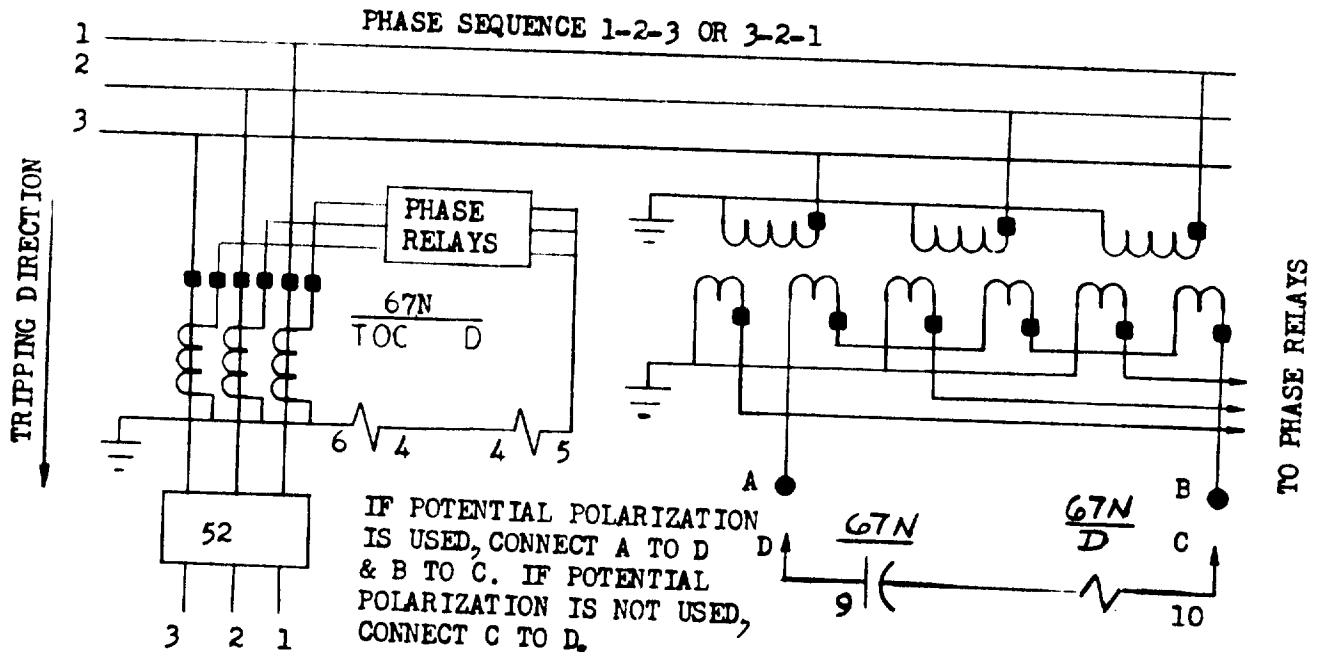
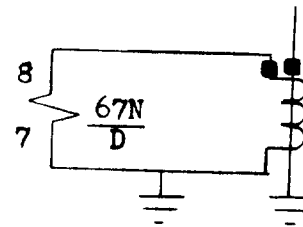

Figure 9 (0127A9424-0) Internal Connections Diagram for the IBCG78M(-)A Relay (Front View)



IF CURRENT POLARIZATION IS NOT USED, DO NOT CONNECT TO STUD 7 & 8.



LEGEND
 67N-IBCG51M, 53M AND 77M
 TOC-TIME OVERCURRENT UNIT
 D-DIRECTIONAL UNIT
 T&SI-TARGET AND SEAL-IN-UNIT

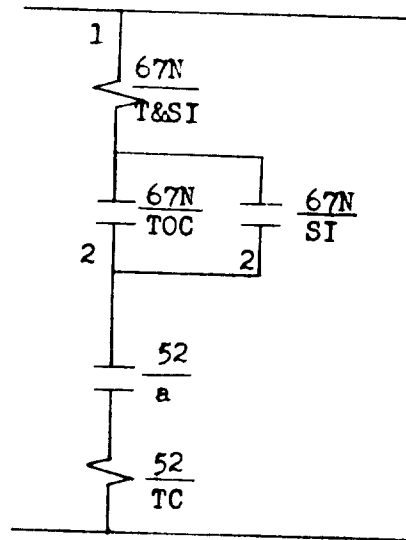
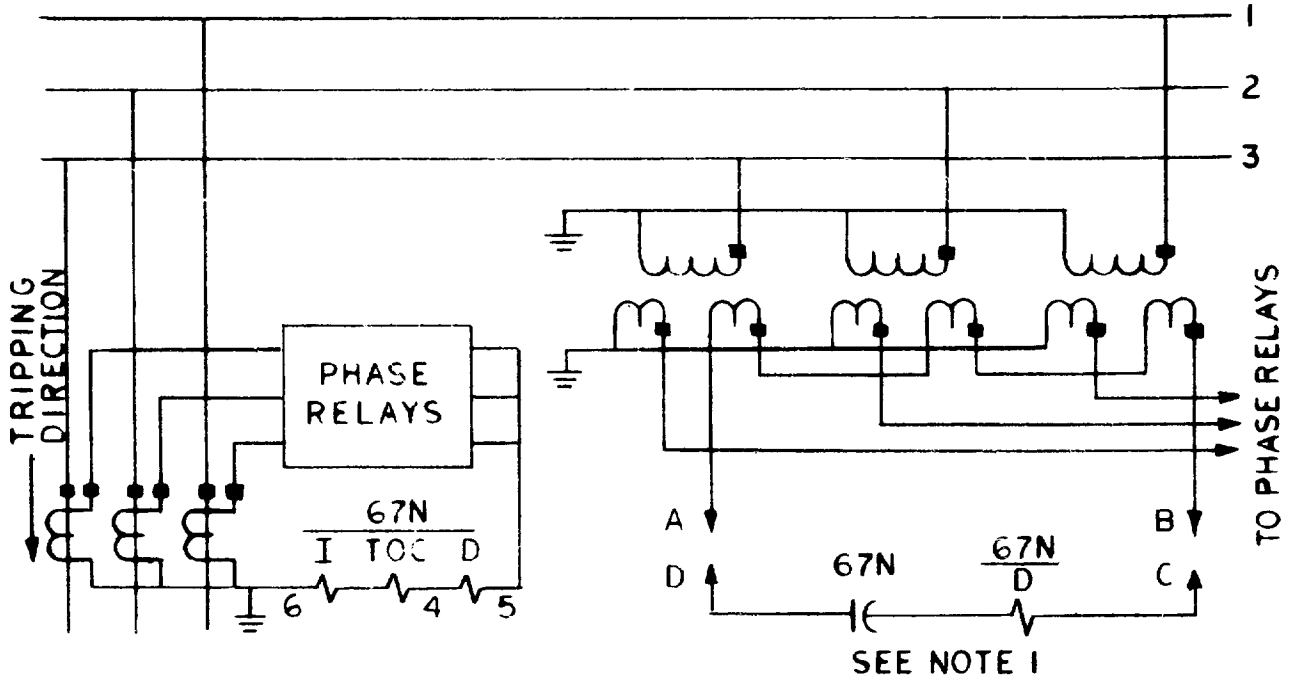

Figure 10 (0273A9051-0) Typical External Connections Diagram for Relay Types IBCG51M, 53M or 77M

PHASE SEQUENCE 1-2-3 OR 3-2-1



NOTES:

1. IF POTENTIAL POLARIZATION IS USED
CONNECT A TO D AND B TO C. IF POTENTIAL
POLARIZATION IS NOT USED CONNECT C TO D

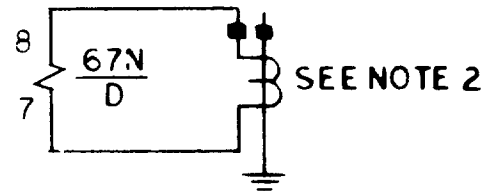

2. IF CURRENT POLARIZATION IS NOT USED
DO NOT CONNECT TO STUDS 7 AND 8

67N-IBCG51M(-)Y1A
IBCG53M(-)Y1A
D-DIRECTIONAL UNIT
I- INSTANTANEOUS UNIT
TOC-TIME OVERCURRENT UNIT

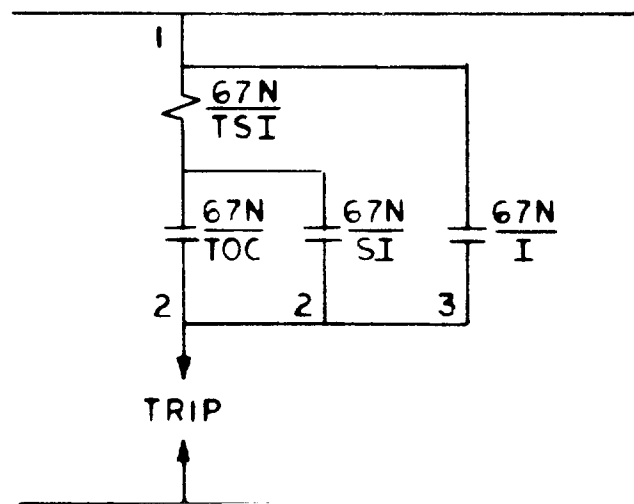

Figure 11 (0273A9052-0) Typical External Connection Diagram
for Relay Type IBCG51M(-)Y1A or 53M(-)Y1A

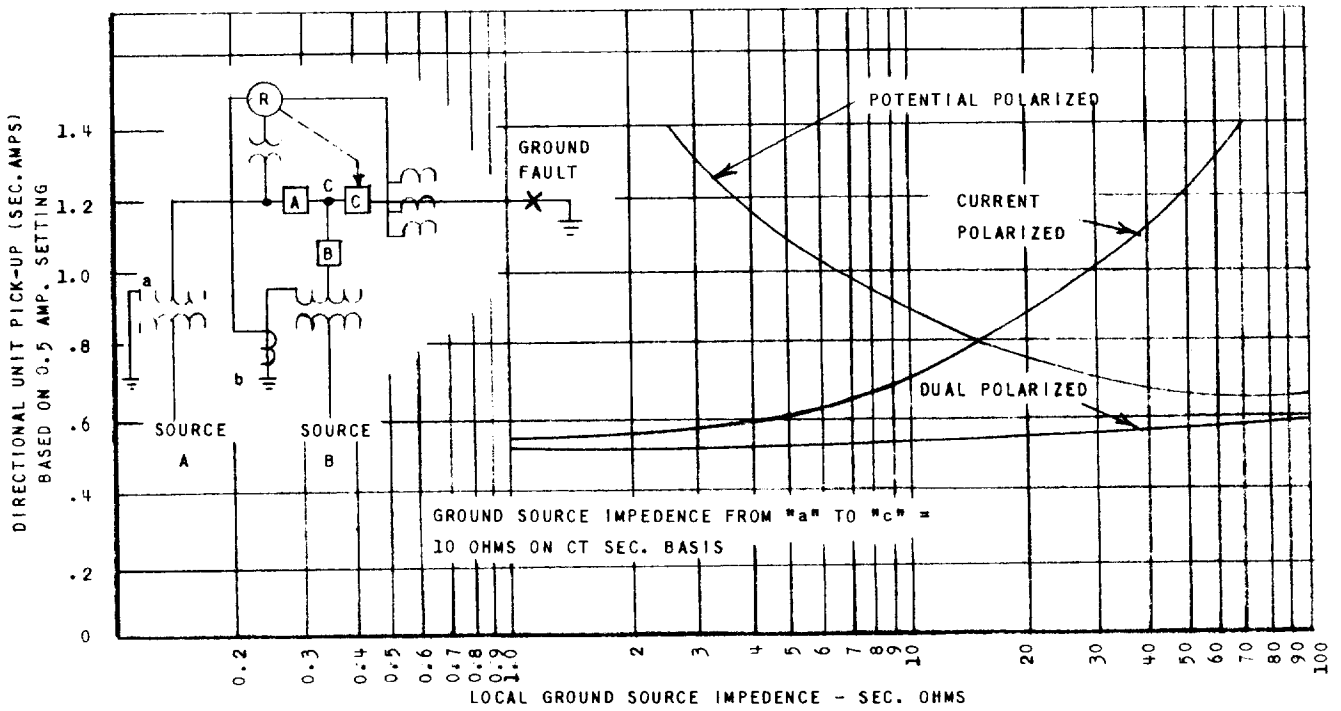

Figure 13 (0362A0684-1) A Typical Comparison of Current, Potential or Dual Polarization Showing Effect of Local Ground Impedance on Directional Unit of Type IBCG Relay

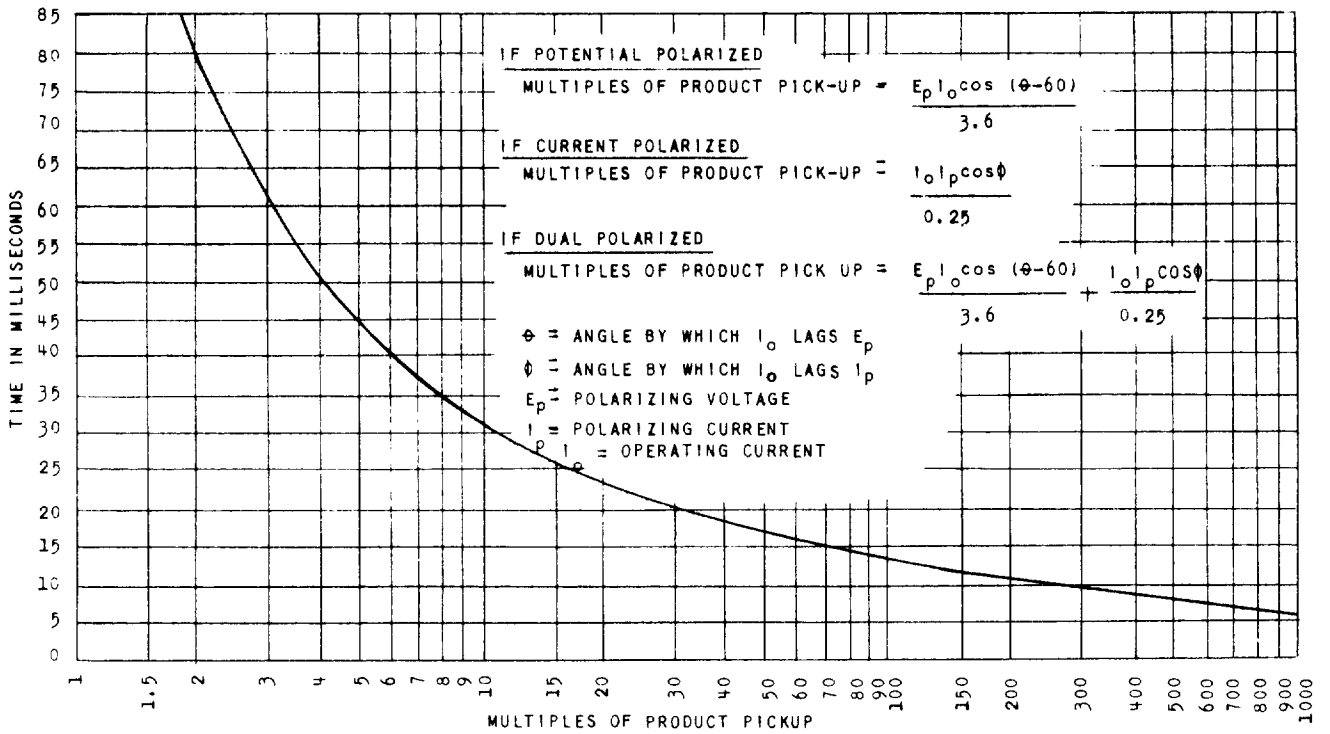

Figure 14 (0376A0934-0) Time Characteristic of Dual Polarized Directional Unit of Type IBCG Relay

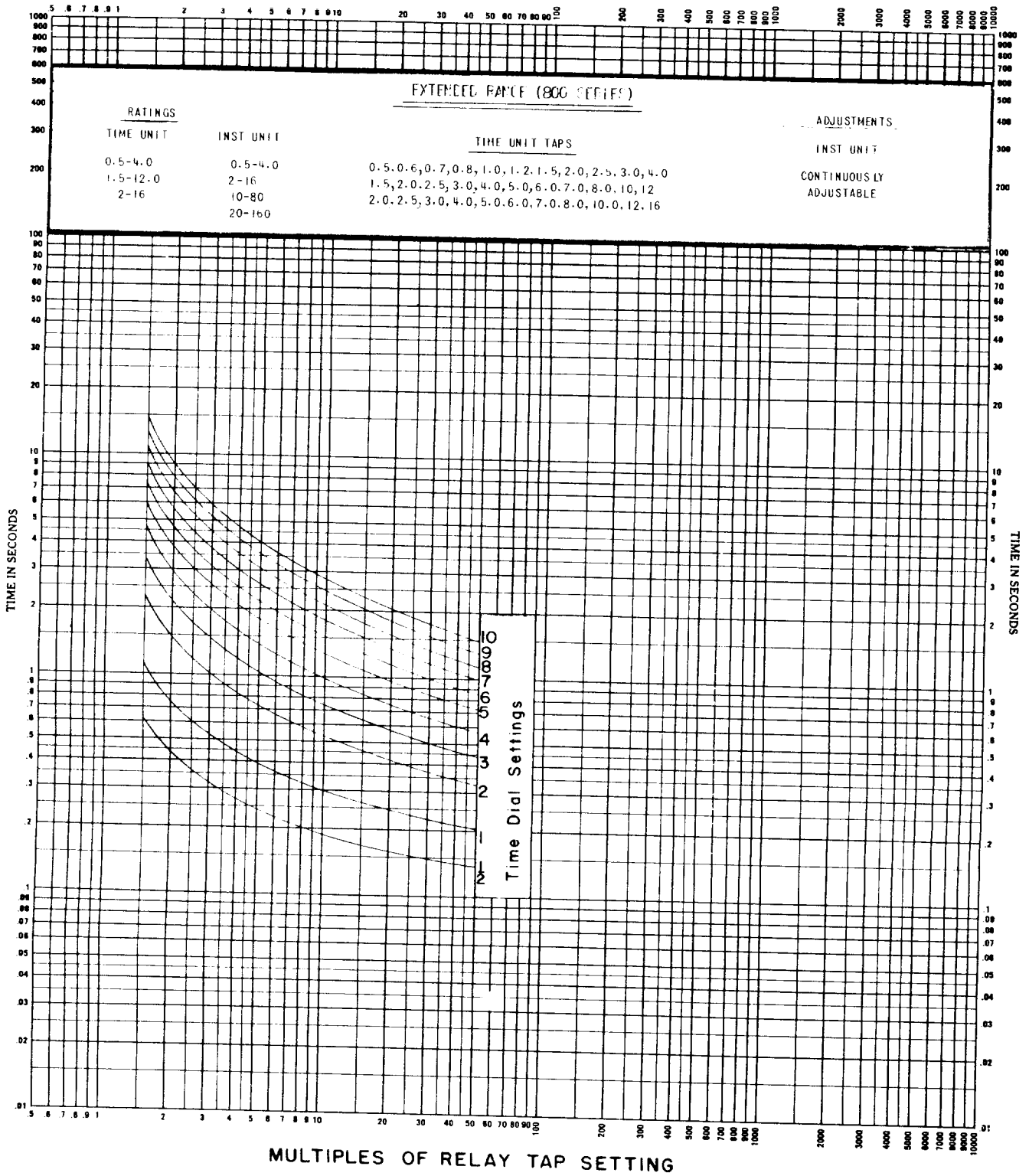

Figure 15 (0888B0269-3) Time-current Characteristic of Inverse Time Overcurrent Unit

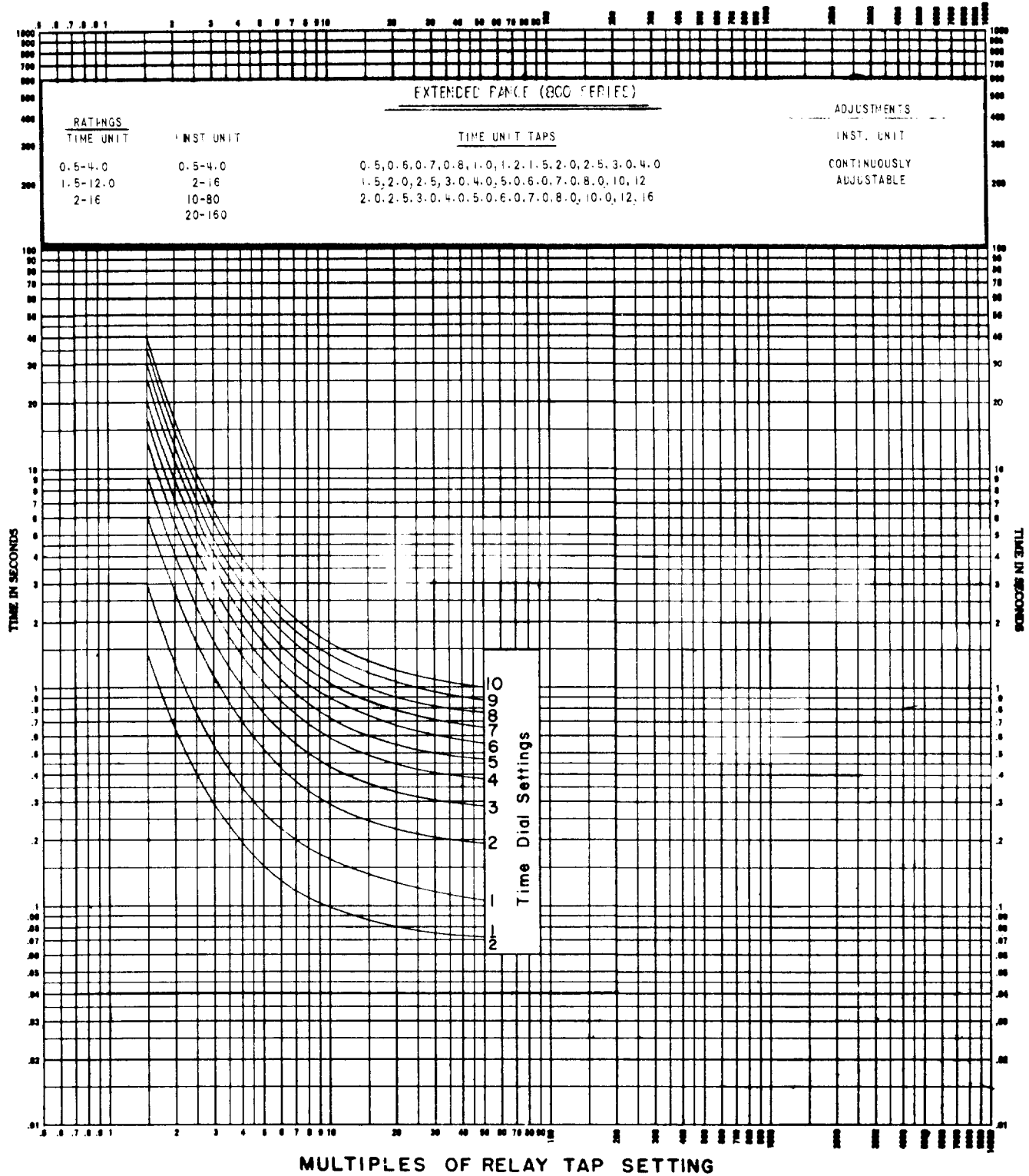

Figure 16 (0888B0270-3) Time-current Characteristic of Very Inverse Time Overcurrent Unit

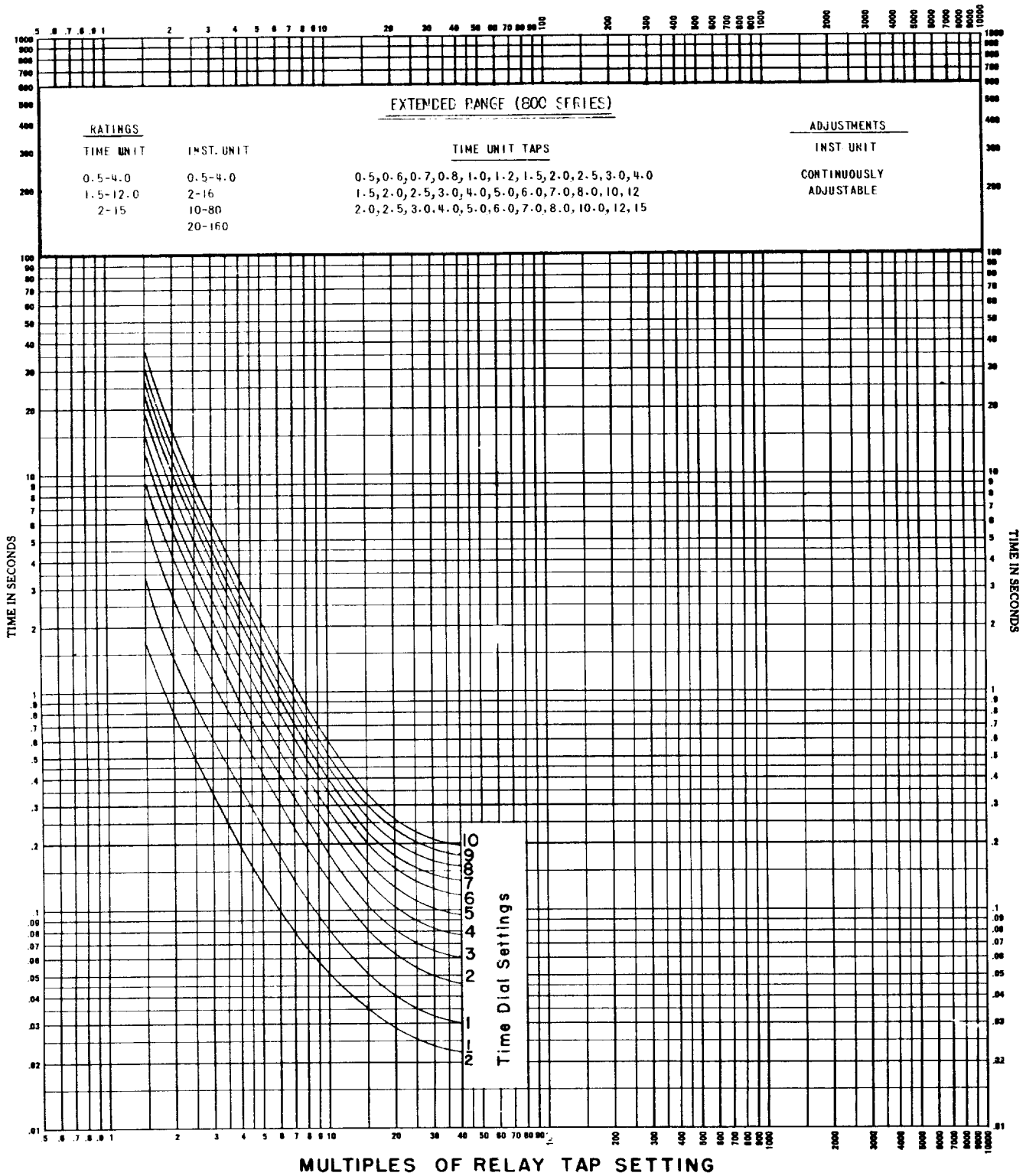

Figure 17 (0888B0274-5) Time-current Characteristic of Extremely Inverse Time Overcurrent Unit

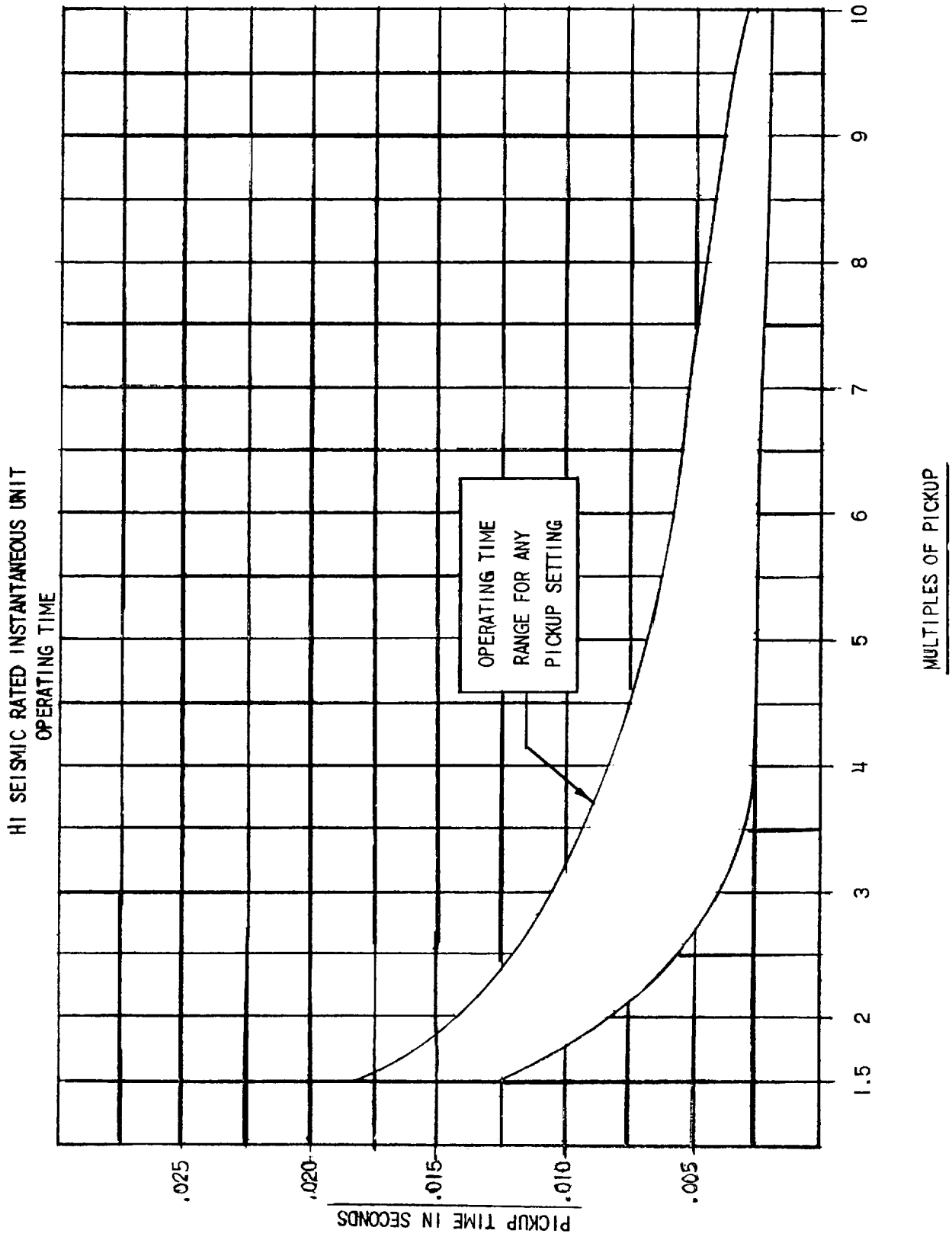

Figure 18 (0208A8695-1) Time-current Characteristics of the Hi-Seismic Instantaneous Unit

HI SEISMIC RATED INSTANTANEOUS UNIT
TRANSIENT OVERREACH

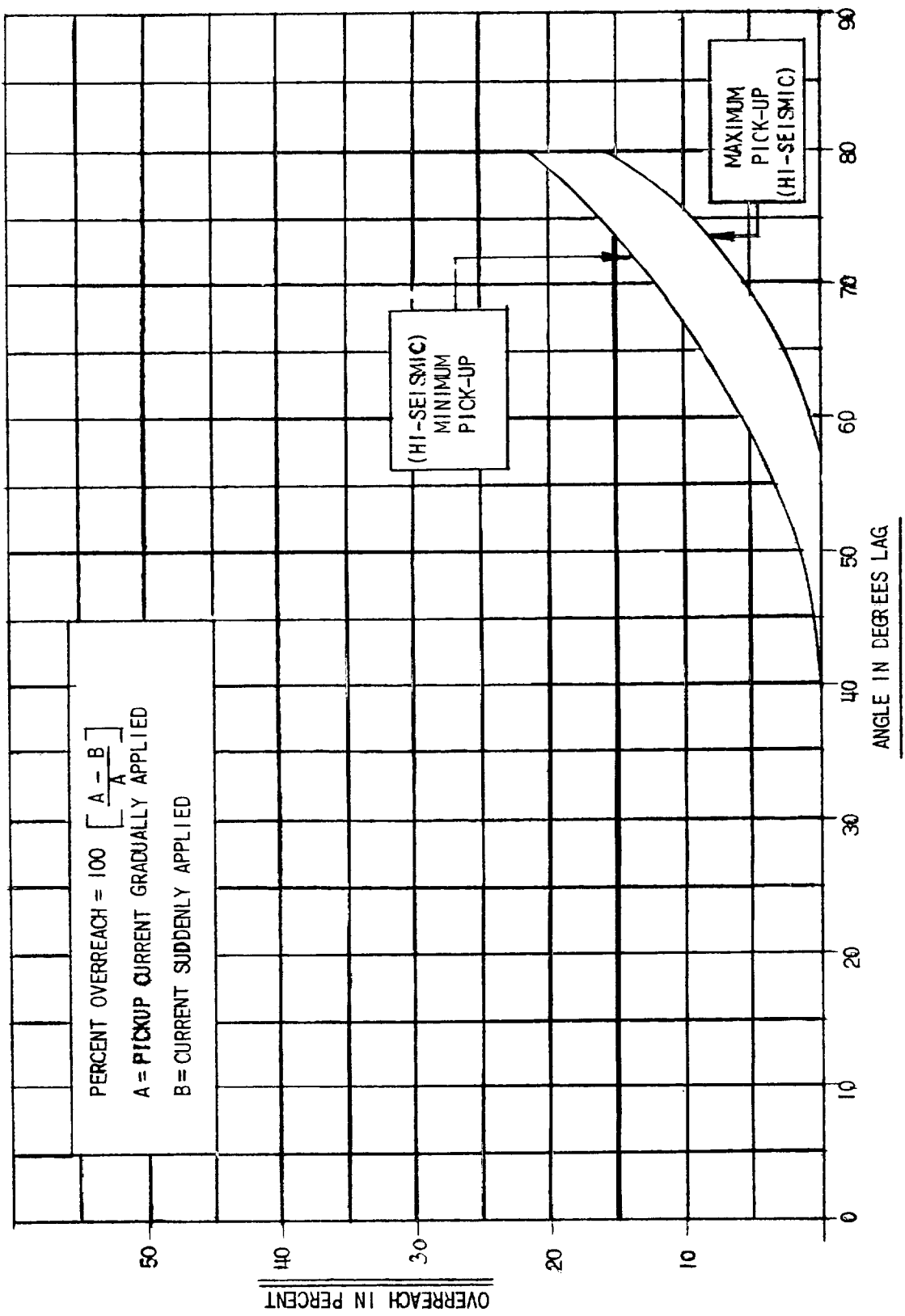
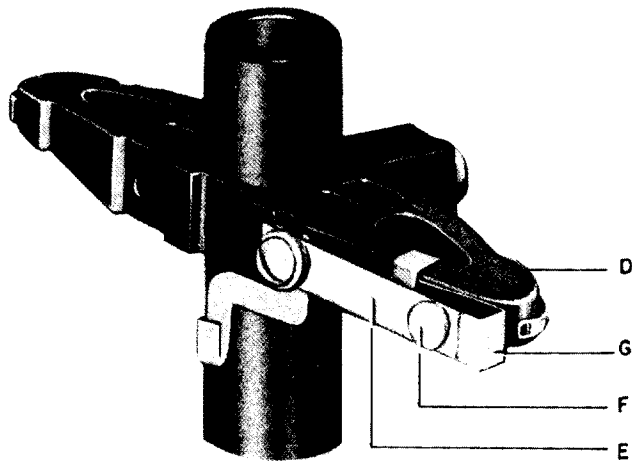

Figure 19 (0208A8694-2) Transient Overreach Characteristics of the Hi-Seismic Instantaneous Unit



- | | |
|---------------------------------------|--------------------------------|
| A - Contact Dial | J - Stop Screw |
| B - Stationary Contact Brush | K - Stationary Contact Support |
| C - Contact Tip | L - Mounting Screw |
| H - Stationary Contact Brush Retainer | M - Locknuts |



- | | |
|--------------------------|-----------------------------------|
| D - Moving Contact Arm | F - Button Contact Tip |
| E - Moving Contact Brush | G - Moving Contact Brush Retainer |

Figure 20 (8027688 and 8023399) Low Gradient Contact Assembly for the Directional Unit

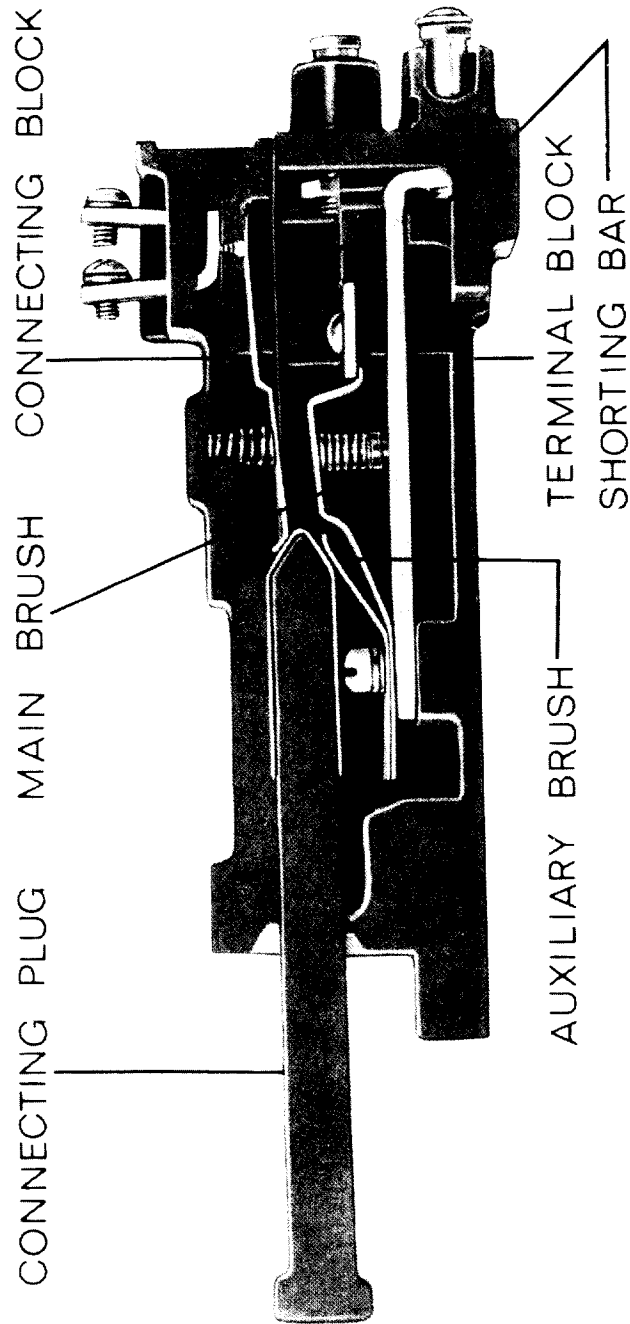

NOTE: AFTER ENGAGING AUXILIARY BRUSH CONNECTING PLUG TRAVELS $\frac{1}{4}$ INCH BEFORE ENGAGING THE MAIN BRUSH ON THE TERMINAL BLOCK

Figure 21 (8025039) Cross Section of Drawout Case Showing Position of Auxiliary Brush

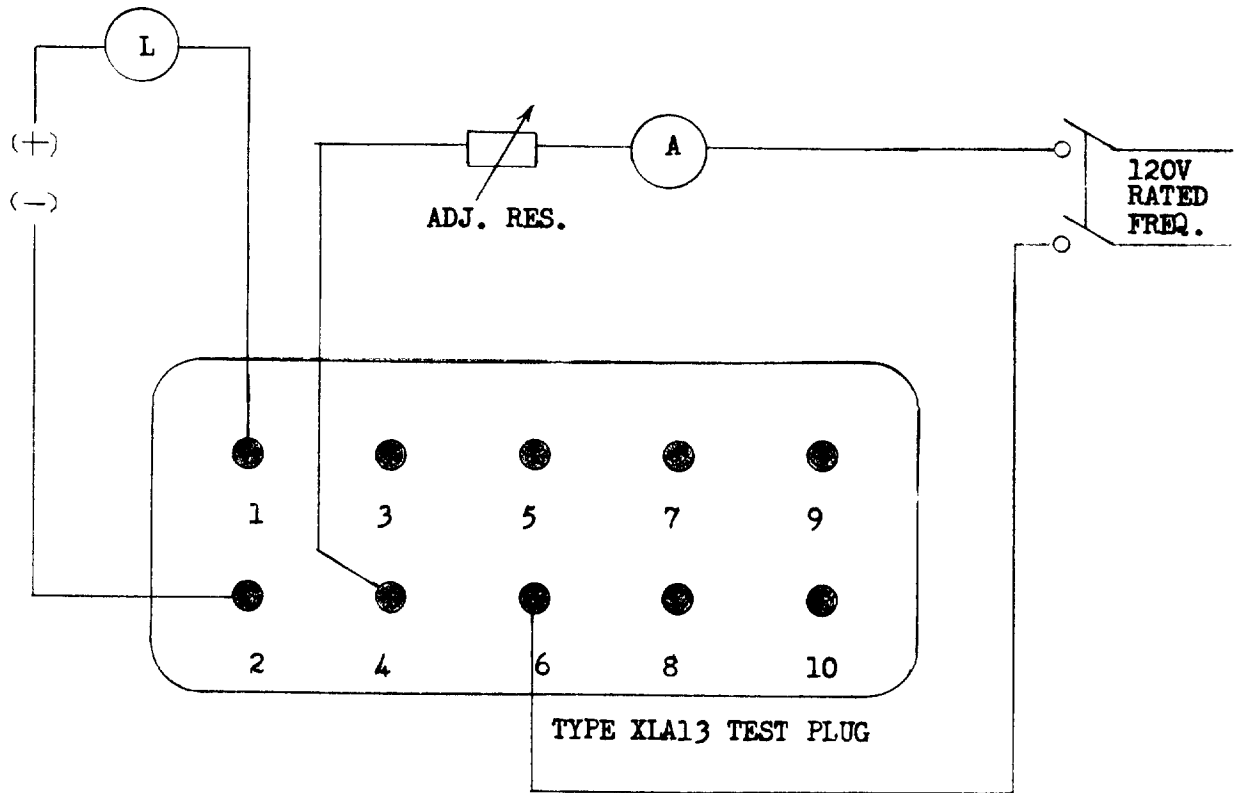

Figure 22 (0195A9179-0) Test Connections for Checking Pickup of TOC Unit

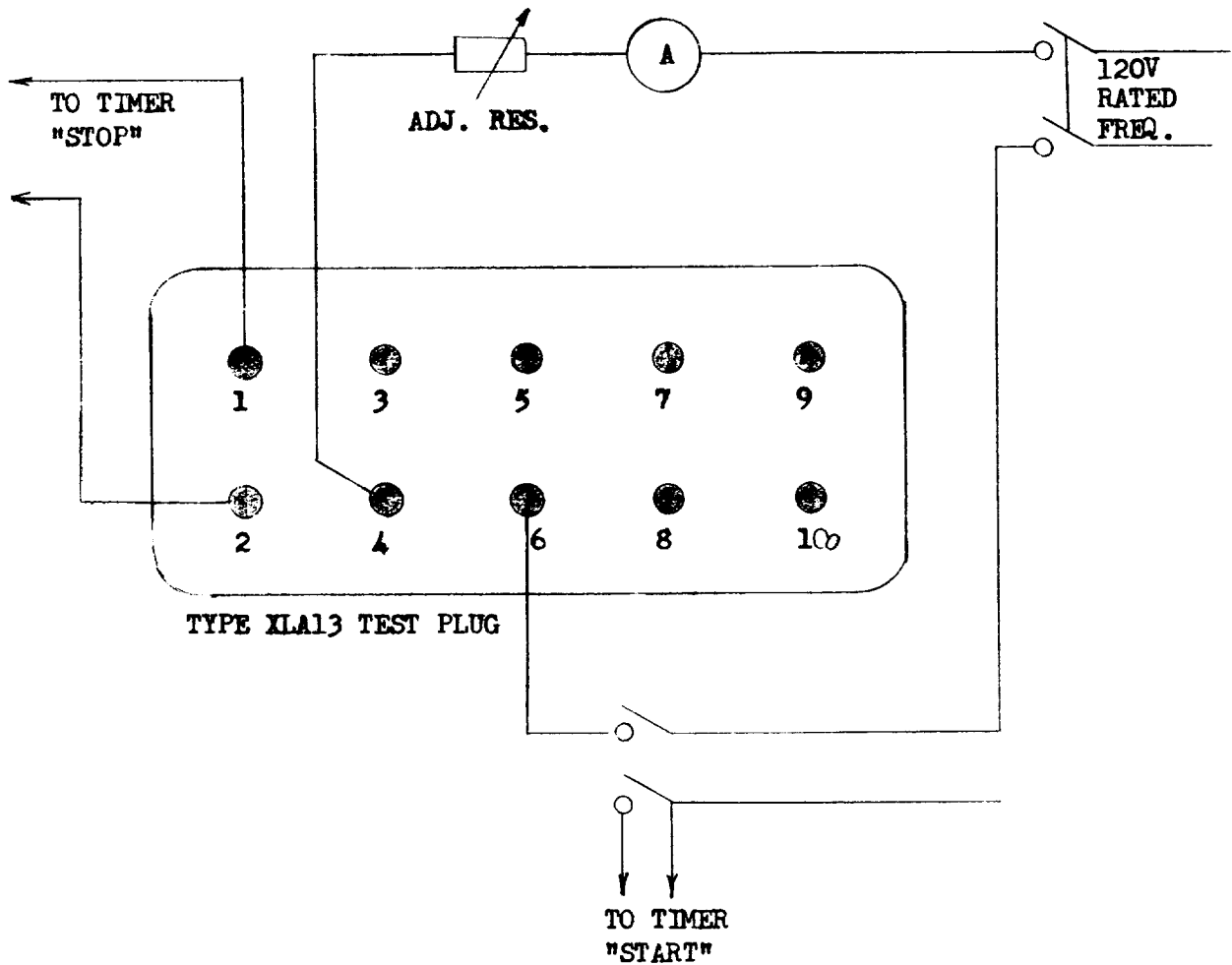
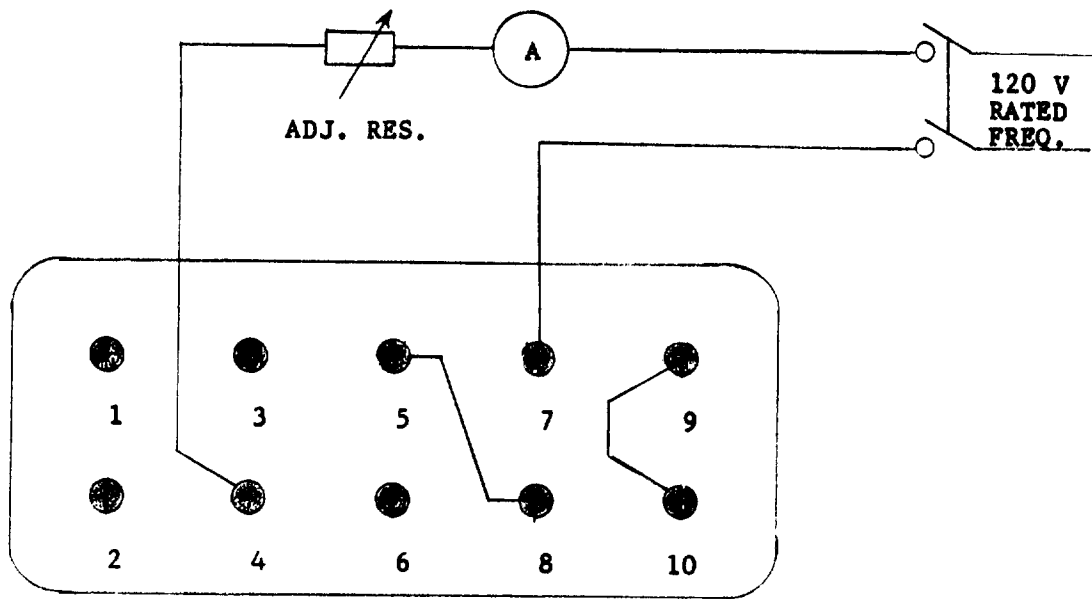

Figure 23 (0195A9180-0) Test Connections for Checking Operating Time of TOC Unit



TYPE XLA13 TEST PLUG

Figure 24 (0195A9181-1) Test Connections for Checking Pickup of Directional Unit using Current Polarization

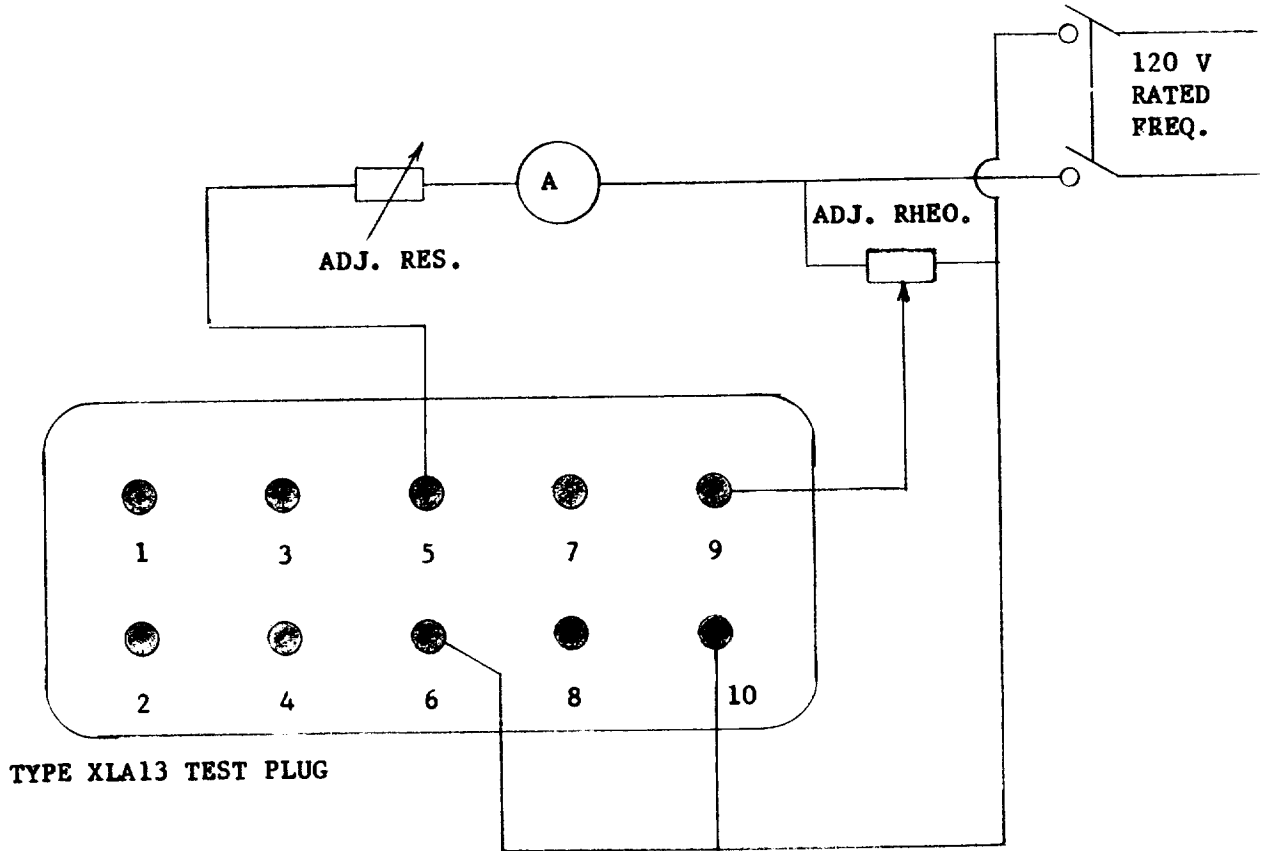

Figure 25 (0195A9182-0) Test Connections for Checking Pickup of Directional Unit using Potential Polarization

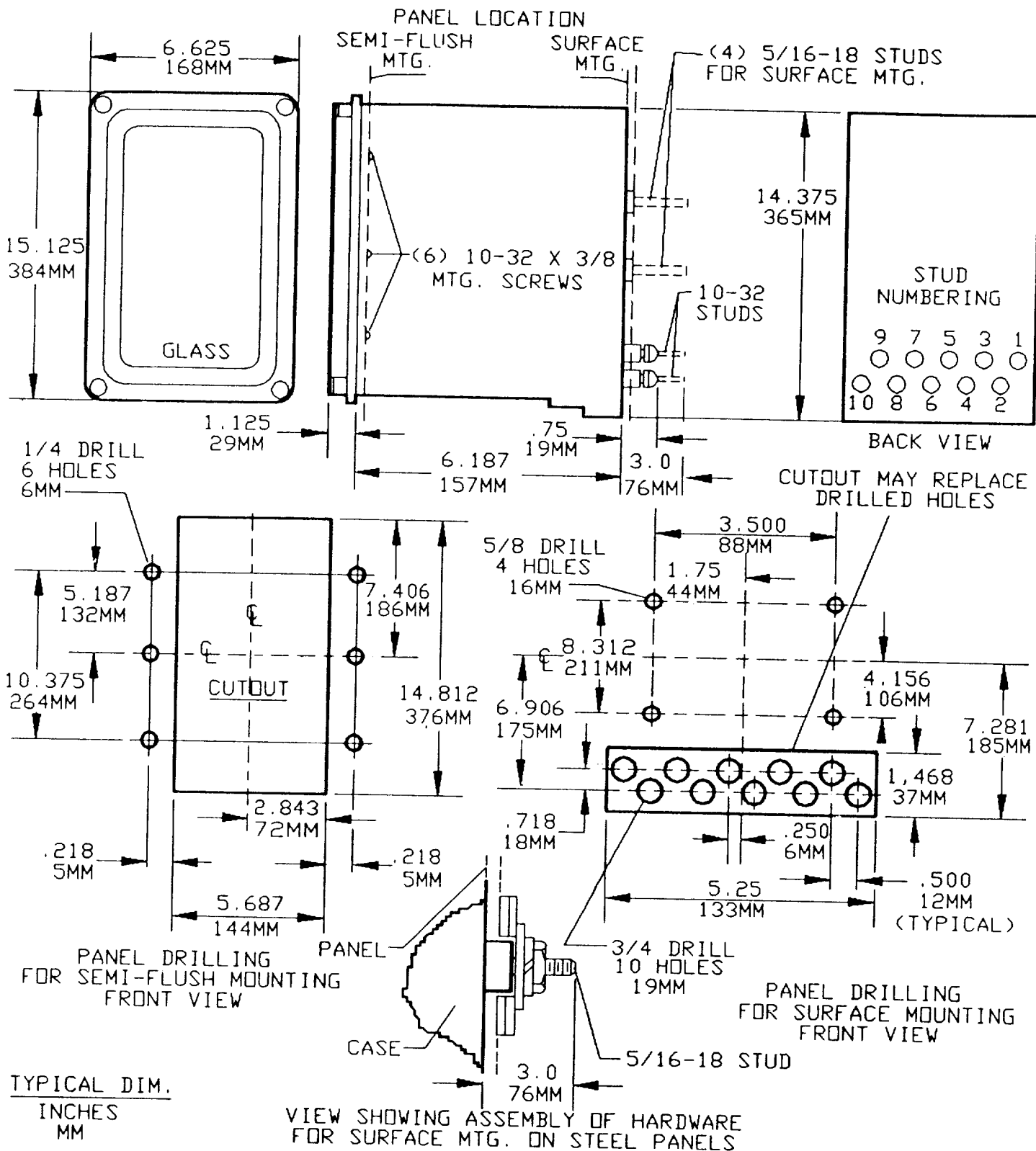

Figure 26 (K-6209273 [5]) Outline and Panel Drilling Dimensions for Type IBCG Relays



GE Power Management

**215 Anderson Avenue
Markham, Ontario
Canada L6E 1B3
Tel: (905) 294-6222
Fax: (905) 201-2098
www.ge.com/indsys/pm**