

# INSTRUCTIONS

GEK-41989A

SUPERSEDES GEK-41989



PHASE DIRECTIONAL OVERCURRENT RELAY

TYPE JBC53L

POWER SYSTEMS MANAGEMENT DEPARTMENT

GENERAL  ELECTRIC

CONTENTS

	<u>PAGE</u>
DESCRIPTION.....	4
APPLICATION.....	4
RATINGS.....	4
CURRENT CIRCUITS.....	4
TABLE I.....	5
TABLE II.....	5
SEAL-IN UNIT.....	5
TABLE III.....	6
CONTACTS.....	6
DC OPERATED AUXILIARY UNIT.....	6
OPERATING CHARACTERISTICS.....	6
PICKUP.....	6
RESET.....	6
OPERATING TIME.....	6
BURDENS.....	6
TABLE IV.....	7
TABLE V.....	7
CONSTRUCTION.....	7
TIME OVERCURRENT UNIT.....	8
DIRECTIONAL UNIT.....	8
INSTANTANEOUS OVERCURRENT UNIT.....	8
SEAL-IN UNIT.....	8
CONTACTS.....	9
LOW GRADIENT CONTACT.....	9
BARREL CONTACT.....	9
AUXILIARY UNIT (X).....	9
RECEIVING, HANDLING AND STORAGE.....	9
ACCEPTANCE TESTS.....	9
VISUAL INSPECTION.....	10
MECHANICAL INSPECTION.....	10
A. TOP UNIT (IOC).....	10
B. MIDDLE UNIT (TOC).....	10
C. BOTTOM UNIT (DIR).....	10
D. TARGET SEAL IN UNIT.....	10
E. TELEPHONE RELAY AUXILIARY UNIT.....	10
INSTALLATION.....	10
LOCATION.....	10
MOUNTING.....	10
CONNECTIONS.....	11
INSPECTION.....	11
CAUTION.....	11
OPERATION.....	11
ADJUSTMENTS.....	11
TARGET AND SEAL-IN UNIT (MARKED "T").....	11
CURRENT SETTING.....	11
TIME SETTING.....	12
EXAMPLE OF SETTING.....	12
DIRECTIONAL UNIT.....	12
POLARITY CHECK.....	12
INSTANTANEOUS OVERCURRENT UNIT.....	12
TARGET AND SEAL-IN UNIT (MARKED "I").....	12
PICKUP SETTING.....	13
SERVICING.....	13
TIME OVERCURRENT UNIT.....	13
DISK AND BEARINGS.....	13
CONTACT ADJUSTMENT.....	13
DIRECTIONAL UNIT.....	13
BEARINGS.....	13
CUP AND STATOR.....	13
CONTACT ADJUSTMENTS.....	14
TORQUE ADJUSTMENT.....	14

CONTENTS (continued)

	<u>PAGE</u>
CLUTCH ADJUSTMENT.....	15
TABLE VI.....	15
INSTANTANEOUS OVERCURRENT UNIT.....	15
BEARINGS.....	15
CUP AND STATOR.....	15
CONTACT ADJUSTMENTS.....	15
TABLE VII.....	15
CONTACT CLEANING.....	16
RENEWAL PARTS.....	16

## DESCRIPTION

The JBC53L relay is a single phase, a-c directional overcurrent relay used primarily for the protection of feeder circuits and transmission lines.

The relay consists of an induction disk time overcurrent unit with very inverse time characteristic, an induction cup instantaneous overcurrent unit, an induction cup instantaneous power-directional unit, two dual-rated target/seal-in units, and a d-c operated auxiliary unit. The instantaneous directional unit is potential polarized and, by means of its closing contacts, directionally controls the operation of both the time overcurrent and instantaneous overcurrent units.

An L2 case is utilized to mount the relay. The outline and mounting dimensions of this case are shown in Figure 13.

## APPLICATION

The type JBC53L directional overcurrent relays are intended primarily for the protection of distribution on transmission lines against multi-phase faults. They are designed specifically for application on circuits where the instantaneous overcurrent unit, because of system characteristics, must be set to pick up below maximum expected full load current, but are equally suited for use where maximum full load will not exceed the required instantaneous unit setting.

The directional unit is potential polarized using the quadrature connection, as shown in the external connection diagram of Figure 15. This connection provides the most reliable form of polarization since fault currents are typically highly lagging. The directional unit is designed to develop maximum torque when the operating current at the relay terminals leads voltage by 45 degrees. Hence with the quadrature connection the directional unit will develop maximum operating torque when the fault current in the tripping direction lags its unity power factor position by 45 degrees.

The very inverse time-current characteristic of the time overcurrent unit, as shown in Figure 12, makes the JBC53L relay particularly well suited for application in locations where the fault current magnitude is determined mainly by the location of the fault in relation to the relay, and only slightly or not at all by the system generation.

The instantaneous overcurrent unit in the JBC53 can, where necessary, be set to pick up at a current below maximum expected load, for example in the range of 2 to 5 amperes, provided of course that this load flow is not in the direction to operate the directional unit. This is made possible by the use of the d-c auxiliary unit X, which isolates the torque control circuit of the instantaneous overcurrent unit. This breaks up a sneak circuit which might otherwise result in the seal in of the instantaneous unit on load following a momentary pickup on a current reversal during the clearing of an external fault. A false trip would then occur on the next external fault which caused the directional unit to operate.

The transient overreach of the instantaneous overcurrent unit is low, thus providing for instantaneous tripping for faults over much of the protected line. However, the pickup of the unit should be at least 10 percent higher than the maximum current at the relay location for any fault at the remote bus.

## RATINGS

### CURRENT CIRCUITS

The continuous and short time ratings of the time overcurrent unit operating coil circuit are shown in Table I. These same ratings are applicable to the directional unit operating coil circuit except that its continuous rating is independent of changes in the time overcurrent unit tap setting. Hence, the information associated with the asterisk under Table II does not apply to the directional unit operating coil. Table II shows the ratings of the available ranges of the instantaneous overcurrent unit. Since all operating current circuits are normally connected in series, the operating coil ratings of all three units should be considered in determining the rating of the entire operating circuit.

*These instructions do not purport to cover all details or variations in equipment nor to provide for every possible contingency to be met in connection with installation, operation or maintenance. Should further information be desired or should particular problems arise which are not covered sufficiently for the purchaser's purposes, the matter should be referred to the General Electric Company.*

*To the extent required the products described herein meet applicable ANSI, IEEE and NEMA standards; but no such assurance is given with respect to local codes and ordinances because they vary greatly.*

TABLE I  
RATINGS OF TIME OVERCURRENT UNIT OPERATING COILS

TAP RANGE (AMPS)	TAP RATINGS (AMPS)	*CONT. RATING (AMPS)	ONE SEC. RATING (AMPS)
1.5/6	1.5,2,2.5,3,4,5,6	5	200
4/16	4,5,6,8,10,12,16	10	220

\* Applies to all taps up to and including this value. The continuous rating of higher current taps is the same as tap value.

TABLE II  
RATINGS OF INSTANTANEOUS OVERCURRENT UNIT OPERATING COILS

PICKUP RANGE (AMPS)	CONTINUOUS RATING (AMPS)	ONE SECOND RATING (AMPS)
2-8	5	160
4-16	5	160
10-40	5	220
20-80	5	220
40-160	5	220

SEAL-IN UNIT

The rating and impedance of the seal-in unit for the 0.2 and 2 ampere taps are given in Table IV. The tap setting used will depend on the current drawn by the trip coil. The current ratings are either AC or DC.

The 0.2 ampere tap is for use with trip coils which operate on currents ranging from 0.2 up to 2.0 amperes, at the minimum control voltage. If this tap is used with trip coils requiring more than 2 amperes, there is a possibility that the resistance of 7 ohms will reduce the current to so low a value that the breaker will not be tripped.

The 2 ampere tap should be used with trip coils that take two amperes or more at minimum control voltage, provided the current does not exceed 30 amperes at the maximum control voltage. If the tripping current exceeds 30 amperes, the connections should be arranged so that the induction unit contacts will operate an auxiliary relay which in turn energizes the trip coil or coils. On such an application, it may be necessary to connect a loading resistor in parallel with the auxiliary relay coil to allow enough current to operate the target seal-in unit.

TABLE III  
SEAL-IN UNIT RATINGS

	2 AMP TAP	0.2 AMP TAP
Carry-Tripping Duty	30 Amps	3 Amps
Carry Continuously	3 Amps	0.3 Amps
DC Resistance	0.13 Ohms	7 Ohms
Impedance (60 Cycles)	0.53 Ohms	52 Ohms

CONTACTS

The current-closing rating of the induction unit contacts is 30 amperes for voltages not exceeding 250 volts. Their current-carrying rating is limited by the tap rating of the seal-in unit.

DC OPERATED AUXILIARY UNIT

JBC53L relays are available with the D.C. operated auxiliary unit rated either 48 or 125 or 250 volts D.C.

OPERATING CHARACTERISTICSPICKUP

At the maximum torque angle, the directional unit will pick up at one percent of rated voltage with 2 amperes for relays with 1.5/6 ampere time overcurrent units, and 4 amperes for relays with 4/16 ampere time overcurrent units.

The maximum operating current required to close the time overcurrent unit contacts, at any time-dial position, will be within five percent of the tap plug setting.

The pickup of the instantaneous overcurrent unit can be adjusted over a four-to-one range as indicated in Table II.

RESET

The minimum percentage of minimum closing current at which the time overcurrent unit will reset is 85% for very inverse time relays. When the relay is de-energized, the time required for the disk to completely reset to the number 10 time dial position is approximately 60 seconds.

OPERATING TIME

The time curves for the directional unit are shown in Figure 10 and Figure 11.

The time curves of the very inverse time overcurrent unit are shown in figure 12. For the same operating conditions, the time overcurrent will operate repeatedly within one or two percent of the same time.

The time curves for the instantaneous overcurrent unit are shown in figure 9.

BURDENS

The potential circuit burden of the directional unit at 60 cycles and rated volts is 10 volt-amperes at 0.89 power factor. Table IV gives the current circuit burden of the directional unit. Table V gives the total burden of the time overcurrent unit plus instantaneous overcurrent unit.

TABLE IV

DIRECTIONAL UNIT CURRENT CIRCUIT BURDENS AT 60 CYCLES AND 5 AMPERES

TAP RANGE	IMPED. (OHMS)	VOLT-AMPERES	POWER FACTOR	WATTS
1.5/6	0.46	12.0	0.52	6.24
4/16	0.13	3.3	0.40	1.32

\* TABLE V

BURDENS OF OVERCURRENT UNITS (TIME AND INSTANTANEOUS)

AT 60 CYCLES

TIME CHARACTERISTIC	RANGE		BURDENS AT MINIMUM PICKUP OF TIME UNIT					OHMS IMPEDANCE AT		≠ VA AT 5 AMPS
	TIME UNIT	INST. UNIT	EFF. RES. (OHMS)	REACT. (OHMS)	*IMPED. (OHMS)	+ VOLT-AMPS	POWER FACTOR	3 TIMES MIN. P.U.	10 TIMES MIN. P.U.	
VERY INVERSE	1.5/6	2-8	0.32	0.60	0.68	1.5	0.47	0.64	0.55	17
VERY INVERSE	1.5/6	4-16 10-40 20-80	0.25	0.51	0.57	1.3	0.44	0.53	0.46	14
VERY INVERSE	4/16	2-8	0.14	0.13	0.19	3.0	0.73	0.18	0.15	4.7
VERY INVERSE	4/16	4-16	0.09	0.11	0.14	2.2	0.64	0.13	0.11	3.5
VERY INVERSE	4/16	10-40 20-80	0.06	0.10	0.12	1.9	0.50	0.11	0.10	3.0

\* The impedance values given are those for the minimum tap of each relay. The impedance for other taps, at pick-up current (tap rating), varies inversely approximately as the square of the current rating.

+ Some companies list relay burdens only as the volt-ampere input to operation at minimum pickup. This column is included so a direct comparison can be made. It should not be used in calculating volt-ampere burdens in a CT secondary circuit, since the burden at 5 amperes is used for this purpose.

≠ Calculated from burden at minimum pickup.

CONSTRUCTION

The JBC53L consists of a directional unit, a time-overcurrent unit, an instantaneous unit, a D.C. operated telephone relay auxiliary unit and two target/seal-in units mounted in a large double-ended drawout (L2) case. The outline and panel drilling diagram for the L2 case is shown in Figure 13. The internal connections diagram is shown in Figure 2.

The directional unit is mounted in the bottom of the case, the time overcurrent unit in the middle, and the instantaneous overcurrent unit in the top. The auxiliary unit is mounted behind the directional unit.

TIME OVERCURRENT UNIT

The very inverse time overcurrent unit consists of a tapped current operating coil wound on a U-magnet iron structure. The tapped operating coil is connected to taps on the tap block. The U-magnet contains wound shading coils which are connected in series with an auxiliary unit contact.

When power flow is in such a direction as to close the directional unit contacts, the DC auxiliary unit will close its contacts, provided D.C. control voltage is present, short circuiting the shading coil circuit and allowing the time overcurrent unit to produce torque on the induction disk.

The disk shaft carries the moving contact which completes the trip circuit when it touches the stationary contact or contacts. The shaft is restrained by a spiral spring to give the proper contact closing current, and its motion is retarded by a permanent magnet acting on the disk to produce the desired time characteristic. The variable retarding force resulting from the gradient of the spiral spring is compensated by the spiral shape of the induction disk, which results in an increased driving force as the spring winds up.

The operating circuit of the DC auxiliary unit and the torque control circuits of the instantaneous overcurrent unit are both wired to terminals on the relay contact block. These terminals are shorted together by internally connected a red jumper lead when the relays leave the factory (see Figure 2). If external torque control is desired, this jumper lead may be removed.

DIRECTIONAL UNIT

The directional unit is of the induction-cylinder construction with a laminated stator having eight poles projecting inward and arranged symmetrically around a stationary central core. The cuplike aluminum induction rotor is free to operate in the annular air gap between the poles and the core. The poles are fitted alternately with current operating coils and potential polarizing coils.

The principle by which torque is developed is the same as that of an induction disk relay with a wattmetric element, although, in arrangement of parts, the unit is more like a split-phase induction motor. The induction-cylinder construction provides higher torque and lower rotor inertia than the induction-disk construction, resulting in a faster and more sensitive relay.

INSTANTANEOUS OVERCURRENT UNIT

The instantaneous overcurrent unit is similar in construction to the directional unit described above, differing only in coil turns and connections. The four corner coils consist of two windings, an inner winding consisting of a large number of turns of fine wire, and an outer winding having a few turns of heavy wire. The outer windings of the corner coils, together with the four side coils, are all connected in series with the operating coil of the time overcurrent unit. The inner windings of the corner coils are all connected in series, and in turn are connected in series with a capacitor and a contact of the directional unit. This circuit thus controls the torque of the instantaneous overcurrent unit. When the directional unit contacts are open, the instantaneous overcurrent unit will develop no torque. When the directional unit contacts are closed, the instantaneous overcurrent unit will develop torque in proportion to the square of the current.

The instantaneous overcurrent unit develops operating torque in a direction opposite to that of the directional unit. This makes the relay less susceptible to the effects of shock.

SEAL-IN UNIT

The seal-in units for both the time-overcurrent and instantaneous-overcurrent contacts are mounted on the middle unit, as indicated in Fig. 1.

The left seal-in unit operates in conjunction with the time-overcurrent unit contacts and is labeled "T". Its coil is in series and its contacts in parallel with the main contacts of the time-overcurrent unit so that when the main contacts close, the seal-in unit will pick up and seal-in around the main contact.

The right seal-in unit, labeled "I" operates in conjunction with the instantaneous overcurrent unit. Its coil is in series with the instantaneous unit contact and a contact of the directional unit, and its contacts are connected to seal-in around these two contacts when the unit operates.



Both seal-in units are equipped with targets which are raised into view when the unit operates. These targets latch and remain exposed until manually released by means of the button projecting below the lower left corner of the cover.

### CONTACTS

#### LOW GRADIENT CONTACT

The directional unit contacts (left front), which control the time overcurrent unit are shown in Figure 4. They are of the low gradient type specially constructed to minimize the effects of vibration. Both the stationary and moving contact brushes are made of low gradient material which, when subjected to vibration, tend to follow one another, hence, they resist contact separation.

The contact dial (A) supports the stationary contact brush (B) on which is mounted a conical contact tip (C). The moving contact arm (D) supports the moving contact brush (E) on which is mounted a button contact tip (F). The end of the moving contact brush bears against the inner face of the moving contact brush retainer (G). Similarly, the end of the stationary contact brush bears against the inner face of the stationary contact brush retainer (H). The stationary contact support (K) and the contact dial are assembled together by means of a mounting screw (L) and two locknuts (M).

#### BARREL CONTACT

The directional unit contacts (right rear), which control the instantaneous overcurrent unit, are shown in Figure 3. They are specially constructed to suppress bouncing. The stationary contact (G) is mounted on a flat spiral spring (F) backed up by a thin diaphragm (C). These are both mounted in a slightly inclined tube (A). A stainless steel ball (B) is placed in the tube before the diaphragm is assembled. When the moving contact hits the stationary contact, the energy of the former is imparted to the latter and thence to the ball, which is free to roll up the inclined tube. Thus, the moving contact comes up to rest with substantially no rebound or vibration. To change the stationary contact mounting spring, remove the contact barrel and sleeve as a complete unit after loosening the screw at the front of the contact block. Unscrew the cap (E). The contact and its flat spiral mounting spring may then be removed.

#### AUXILIARY UNIT (X)

Figure 14 shows a typical telephone relay type auxiliary unit used in JBC53L relays to control the time overcurrent unit. This unit inserts additional resistance in its operating coil circuit as it picks up by opening its normally closed contact which is across a series resistor (See R4 in Figure 2). This allows fast pickup and dropout with a continuously rated auxiliary circuit.

### RECEIVING, HANDLING AND STORAGE

These relays, when not included as a part of a control panel will be shipped in cartons designed to protect them against damage. Immediately upon receipt of a relay, examine it for any damage sustained in transit. If injury or damage resulting from rough handling is evident, file a damage claim at once with the transportation company and promptly notify the nearest General Electric Apparatus Sales Office.

Reasonable care should be exercised in unpacking the relay in order that none of the parts are injured or the adjustments disturbed.

If the relays are not to be installed immediately, they should be stored in their original cartons in a place that is free from moisture, dust and metallic chips. Foreign matter collected on the outside of the case may find its way inside when the cover is removed and cause trouble in the operation of the relay.

### ACCEPTANCE TESTS

Immediately upon receipt of the relay an INSPECTION AND ACCEPTANCE TEST should be made to insure that no damage has been sustained in shipment and that the relay calibrations have not been disturbed. If the examination or test indicates that readjustment is necessary, refer to the section on SERVICING.

VISUAL INSPECTION

Check the nameplate stamping to insure that the model number and rating of the relay agree with the requisition.

Remove the relay from its case and check that there are no broken or cracked molded parts or other signs of physical damage and that all screws are tight. Check that the shorting bars are in the proper location(s) and that they are properly formed (See Figure 5).

MECHANICAL INSPECTIONA. TOP UNIT (IOC)

1. The rotating shaft end play should be 0.015-0.020 inches.
2. The contact gap should be 0.028-0.036 inches.
3. There should be no noticeable friction in the rotating structure.
4. With the relay well leveled and in its upright position, the contact should be open and resting against the backstop.

B. MIDDLE UNIT (TOC)

1. The disk shaft end play should be 0.005-0.015 inches.
2. The disk should be centered in the air gaps of both the electro magnet and drag magnet.
3. Both air gaps should be free of foreign matter.
4. The disk should rotate freely.
5. The moving contact should just touch the stationary contact when the time dial is at the zero time dial position.

C. BOTTOM UNIT (DIR)

1. The rotating shaft end play should be 0.015-0.020 inches.
2. The contact gap should be 0.015-0.025 inches on the low gradient front contact.
3. The front contact should close approximately 0.005 to 0.010 inches before the rear contacts.

D. TARGET SEAL IN UNIT

1. Both contacts should make at approximately the same time.
2. The target should latch into view just as the contacts make.
3. The contacts should have approximately .030 inch wipe.

E. TELEPHONE RELAY AUXILIARY UNIT

1. With the relay de-energized each normally open contact should have a gap of .010"-.015".
2. The wipe on each normally closed contact should be approximately .005". This can be observed by deflecting the stationary contact member towards the frame.
3. The wipe on each normally open contact should be approximately .005". This can be checked by inserting a .005" shim between the armature and the pole piece and operating the armature by hand. The normally open contacts should make before the residual pin strikes the shim.

INSTALLATIONLOCATION

The location should be clean and dry, free from dust and excessive vibration and well lighted to facilitate inspection and testing.

MOUNTING

The relay should be mounted on a vertical surface. The outline and panel drilling diagram is shown in Figure 13.

CONNECTIONS

The internal connection diagram for the relay is shown in Figure 2. A typical wiring diagram is shown in Figure . Since phase sequence is important for the correct operation of Type JBC relays, the rotation specified in Figure must be adhered to. Unless mounted on a steel panel which adequately grounds the relay case, it is recommended that the case be grounded through a mounting stud or screw with a conductor not less than #12 B&S gage copper wire or its equivalent.

INSPECTION

At the time of installation, the relay should be inspected for tarnished contacts, loose screws, or other imperfections. If any trouble is found, it should be corrected in the manner described under MAINTENANCE.

CAUTION

EVERY CIRCUIT IN THE DRAWOUT CASE HAS AN AUXILIARY BRUSH. IT IS ESPECIALLY IMPORTANT ON CURRENT CIRCUITS AND OTHER CIRCUITS WITH SHORTING BARS THAT THE AUXILIARY BRUSH BE BENT HIGH ENOUGH TO ENGAGE THE CONNECTING PLUG OR TEST PLUG BEFORE THE MAIN BRUSHES DO. THIS WILL PREVENT CT SECONDARY CIRCUITS FROM BEING OPENED. SEE FIGURE 5.

OPERATION

Before the relay is put into service, it should be given a check to determine that factory adjustments have not been disturbed. The time dial will be set at zero before the relay leaves the factory. It is necessary to change this setting in order to open the time overcurrent unit contacts.

ADJUSTMENTSTIME OVERCURRENT UNITTARGET AND SEAL-IN UNIT (MARKED "T")

When used with trip coils operating on currents ranging from 0.2 to 2.0 amperes at the minimum control voltage, the target and seal-in tap screw should be set in the 0.2 ampere tap. When the trip coil current ranges from 2 to 30 amperes at the minimum control voltage, the tap screw should be placed in the 2.0 ampere tap.

The seal-in tap screw is the screw holding the right-hand stationary contact of the seal-in unit. To change the tap setting, first remove the connecting plug. Then take a screw from the left-hand stationary contact and place it in the desired tap. Next, remove the screw from the other tap and place it back in the left-hand contact. This procedure is necessary to prevent the right-hand stationary contact from getting out of adjustment. Tap screws should never be left in both taps at the same time.

CURRENT SETTING

The minimum current at which time overcurrent unit will close its contacts is determined by the position of the plug in the tap block. The tap plate on this block is marked in amperes, as shown in Table I.

When the tap setting is changed with the relay in its case the following procedure must be followed: (1) remove the connecting plug; this de-energizes the relay and shorts the current transformer secondary winding. (2) remove the tap screw and place it in the tap marked for the desired pick-up current. (3) replace the connecting plug.

The minimum current required to rotate the disk slowly and to close the contacts should be within five percent of the value marked on the tap plate for any tap setting and time dial position. If this adjustment has been disturbed, it can be restored by means of the spring adjusting ring. The ring can be turned by inserting a screw driver blade in the notches around the edge. By turning the ring, the operating current of the unit can be brought into agreement with the tap setting employed. This adjustment also permits any desired setting to be obtained intermediate between the available tap settings.

Test connections for making pickup and time checks on the time overcurrent unit are shown in Figure 6. Use a source of 120 volts or greater with good wave form and constant frequency. Stepdown transformers or phantom loads should not be employed in testing induction relays since their use may cause a distorted wave form.

TIME SETTING

The operating time of the time overcurrent unit for any given value of current and tap setting is determined by the time dial setting. This operating time is inversely proportional to the current magnitude as illustrated by the time curves in Figure 12. Note that the current values on these curves are given as multiples of the tap setting. That is, for a given time dial setting, the time will be the same for 80 amperes on the 8 ampere tap as for 50 amperes on the 5 ampere tap, since in both cases, the current is 10 times tap setting.

If selective action of two or more relays is required, determine the maximum possible short-circuit current of the line and then choose a time value for each relay that differs sufficiently to insure the proper sequence in the operation of the several circuit breakers. Allowance must be made for the time involved in opening each breaker after the relay contacts close. For this reason, unless the circuit time of operation is known with accuracy, there should be a difference of about 0.5 second (at the maximum current) between relays whose operation is to be selective.

EXAMPLE OF SETTING

The time and current settings of the time overcurrent unit can be made easily and quickly. Each time value shown in Figure 12 indicates the time required for the contacts to close with a particular time-dial setting when the current is a prescribed number of times the current-tap setting. In order to obtain any particular time-current setting, insert the removable plug in the proper tap receptacle and adjust the time dial to the proper position. The following example illustrates the procedure in making a relay setting.

Assume that the relay is being used in a circuit where the circuit breaker should trip on a sustained current of approximately 450 amperes, and that the breaker should trip in one second on a short circuit current of 3750 amperes. Assume further that current transformers of 60/1 ratio are used.

The current-tap setting is found by dividing minimum primary tripping current by the current transformer ratio. In this case, 450 divided by 60 equals 7.5 amperes. Since there is no 7.5 ampere tap, the 8 ampere tap is used. To find the proper time-dial setting to give one second time delay at 3750 amperes, divide 3750 by the transformer ratio. This gives 62.5 amperes secondary current which is 7.8 times the 8 ampere setting. By referring to the time-current curves Figure 12, it will be seen that 7.8 times the minimum operating current gives a one second time delay for a No. 58 time dial setting on a very inverse time relay.

The above results should be checked by means of an accurate timing device. Slight readjustment of the dial can be made until the desired time is obtained.

DIRECTIONAL UNITPOLARITY CHECK

The polarity of the external connections to the directional unit may be verified by observing the direction of contact armature torque when the line is carrying load at unity power factor, or slightly lagging power factor. Note that in most directional overcurrent relay applications, the desired directions are: contact-closing for power flow away from the bus, and contact opening for power flow toward the bus. In case of doubt refer to Figure 7 for a more accurate method of checking the polarity of the connections.

Figure 8 shows the test connections for checking the polarity of the directional unit itself.

INSTANTANEOUS OVERCURRENT UNITTARGET AND SEAL-IN UNIT (MARKED "I")

The target and seal-in unit for the instantaneous overcurrent unit, is mounted on the right-hand side of the time overcurrent unit and is identified by a white "I" engraved on its front. The unit is identical with the target and seal-in unit of the time overcurrent unit, and the same instructions should be followed in adjusting the unit.

PICKUP SETTING

The pickup of the instantaneous overcurrent unit can be adjusted over a four-to-one range, as indicated in Table II, by varying the tension of the spiral control spring. The outside end of this spring is fastened to a post on the adjusting ring above the moving contact, and the ring is in turn clamped in position by a hexagonal-head locking screw. If this screw is loosened, the ring can be slipped to vary the spring tension.

In adjusting pickup, the desired pick-up current should be passed through the coils and the control spring should be adjusted until the contact just closes. The adjusting ring should then be locked in position and the pick-up current rechecked. Note that the telephone relay contacts in the instantaneous unit floating circuit must be jumpered for the instantaneous unit to develop torque.

SERVICING

These relays are adjusted at the factory and it is advisable not to disturb the adjustments. If, for any reason, they have been disturbed, the following points should be observed in restoring them:

TIME OVERCURRENT UNITDISK AND BEARINGS

The jewel should be turned up until the disk is centered in the air gaps, after which it should be locked in this position by the set screw provided for this purpose. The upper bearing pin should next be adjusted so that the disk shaft has about 1/64 inch end play.

CONTACT ADJUSTMENT

The contacts should have about 1/32 inch wipe. That is, the stationary contact tip should be deflected about 1/32 inch when the disk completes its travel. Wipe is adjusted by turning the wipe adjustment screw thereby adjusting the position of the brush relative to the brush stop. On two-circuit closing relays, the two stationary contact tips should be in the same vertical plane.

When the time dial is moved to the position where it holds the contacts just closed, it should indicate zero on the time-dial scale. If it does not and the brushes are correctly adjusted, shift the dial by changing the position of the arm attached to the shaft just below the time dial. Loosen the screw clamping the arm to the shaft and turn the arm relative to the shaft until the contacts just make for zero time-dial setting.

DIRECTIONAL UNITBEARINGS

The lower jewel bearing should be screwed all the way in until its head engages the end of the threaded core support. The upper bearing should be adjusted to allow about 1/64 inch end play in the shaft.

To check the clearance between the iron core and the inside of the rotor cup, press down on the contact arm near the shaft thus depressing the spring-mounted jewel until the cup strikes the iron. The shaft should move about 1/16 inch.

CUP AND STATOR

Should it be necessary to remove the cup-type rotor from the directional unit, the following procedure should be followed:

All leads to the unit should first be disconnected and tagged for identification in reconnecting. The unit can then be removed from the cradle with its mounting plate still attached.

The upper of the three flat-head screws holding the unit to the plate should now be removed. On some models, it may be necessary to remove a resistor or capacitor to expose this screw. The four corner screws clamping the unit together, should next be removed, and the entire top structure lifted off. This gives access to the cup assembly and exposes the stator assembly, which should be protected to keep it free from dust and metallic particles until the unit is reassembled.

To remove the shaft and rotor from the contact head assembly, the spring clip at the top of the shaft must be pulled out and the clutch adjusting screw taken out of the side of the molded contact arm. The shaft and cup can now be pulled out of the molding. The rotor must be handled very carefully while it is out of the unit.

#### CONTACT ADJUSTMENTS

To facilitate adjustment of contacts, use a neon indicating lamp in series with an AC voltage supply across to signify all contact closures. Refer to Figure 4 and Figure 3 for identification of low gradient and barrel contact parts respectively and proceed as follows:

Loosen slightly the locknut which secures the backstop screw (located at the right front corner of the unit) to its support. Unwind the backstop screw so that the moving contact arm is permitted to swing freely. Adjust the tension of each low gradient contact brush so that 1-2 grams of pressure are required at the contact tip in order to cause the end of the brush to separate from the inner face of its respective brush retainer. Adjust the spiral spring until the moving contact arm is in a neutral position, i.e., with the arm pointing directly forward. Loosen the locknut which secures the low gradient stationary contact mounting screw to the stationary contact support. Wind the mounting screw inward until the low gradient stationary and moving contact members just begin to touch. Unwind the mounting screw until the stationary contact brush is vertical with the stationary contact brush retainer down. Then tighten the locknut which secures the mounting screw to the stationary contact support.

Loosen slightly the screw which secures the barrel contact to its support. This screw should be only loose enough to allow the barrel to rotate in its sleeve, but not so loose as to allow the sleeve to move within the support. Wind the backstop screw in until the low gradient moving and stationary contact members just begin to touch. Wind the barrel contact in until the barrel contacts just begin to touch. Unwind the barrel contact 1/4 turn. Tighten the screw which secures the barrel contact to its support. Unwind the backstop screw 2/3 turn. Tighten the locknut screw which secures the backstop screw to its support. Finally, adjust the tension on the low gradient stationary contact brush such that, when the low gradient contacts are made and fully wiped in, there is approximately an equal deflection on each brush.

CAUTION: WHEN THE ABOVE ADJUSTMENTS ARE COMPLETE, BE SURE TO REPLACE THE TWO RED JUMPER LEADS.

#### TORQUE ADJUSTMENT

The directional unit is provided with a notched core which is used to minimize the torque produced on the rotor by current alone in the operating coils with the polarizing circuits de-energized. This adjustment is made at the factory and may be checked as follows:

First, short out the potential polarizing circuit. Adjust the control spring so that the moving contact structure is balanced between the stationary contact and the stop. This can be done by loosening the hexagonal-head locking screw, which clamps the spring adjusting ring in position, and turning the ring to the left until the balance point is reached.

Energize the operating circuit with 30 amperes for relays with 1.5/6 ampere time overcurrent units or 60 amperes for relays with 4/16 ampere time overcurrent units, and check that the contact arm does not move. The core should be turned in small steps until a point is reached where there is no "bias" torque from current alone. The core can be turned by loosening the large hexagonal nut on the bottom of the unit and turning the core by means of the slotted bearing screw. This screw should be held securely in position when the nut is retightened.

Keep in mind that currents of these magnitudes will cause the coils to overheat if left on too long. Therefore, leave the test current on only for short intervals and allow sufficient time between tests for the coils to cool.

After the torque adjustment has been made, the spiral spring should be set to have barely enough tension to swing the moving contact arm against the stop screw when the unit is de-energized. Sufficient tension will be obtained if the adjusting ring is rotated about 1/2 inch from the neutral position in the counterclockwise direction, as measured on the periphery of the ring.

CLUTCH ADJUSTMENT

The connections shown in Figure 8 for the polarity check can also be used in making the clutch adjustment. The 50 ohm fixed resistor should be replaced with an adjustable resistor capable of providing the current range listed in Table VI for the relay type and rating in question. A screw, projecting from the side of the moving contact arm, controls the clutch pressure, and consequently, the current value which will cause the clutch to slip. With rated frequency and at rated volts, the clutch should be set to slip at the current values listed in Table VII. In all cases the current is in phase with the voltage.

TABLE VI

DIRECTIONAL UNIT CLUTCH ADJUSTMENT

TAP RANGE (AMPERES)	AMPERES FOR CLUTCH TO SLIP
1.5/6	11
4/16	22

INSTANTANEOUS OVERCURRENT UNIT

BEARINGS

The section BEARINGS, under DIRECTIONAL UNIT, also applies to the bearings of the instantaneous overcurrent unit.

CUP AND STATOR

The section CUP AND STATOR under DIRECTIONAL UNIT, also applies to the cup and stator of the instantaneous overcurrent unit.

CONTACT ADJUSTMENTS

The contact gap may be adjusted by loosening slightly the screw at the front of the contact support. The screw should be only loose enough to allow the contact barrel to rotate in its sleeve.

The backstop screw fastened with a locknut should hold the moving contact arm in a neutral position, i.e., with the arm pointing directly forward. Then, by rotating the barrel, advance the stationary contact until it just touches the moving contact. Next, back it away 2/3 turn to obtain approximately 0.020 inch gap. Last, tighten the screw which secures the barrel.

The moving contact may be removed by loosening the screw which secures it to the contact arm and sliding it from under the screw head.

TABLE VII

INSTANTANEOUS OVERCURRENT UNIT CLUTCH ADJUSTMENT

PICKUP RANGE	CLUTCH MUST NOT SLIP AT	CLUTCH MUST SLIP AT
2 - 8	12	16
4 - 16	24	32
*10 - 40	-	-
*20 - 80	-	-
*40 - 160	-	-

\* Tighten clutch as much as possible.

The clutch on the instantaneous overcurrent unit can be adjusted by means of the screw located on the right-hand side of the moving contact arm. If the locknut is loosened and the screw turned in, the current at which the clutch will slip will be increased. The clutch should be adjusted to slip at the current values shown in Table VII with the directional unit contacts held closed.

#### CONTACT CLEANING

For cleaning silver contacts, a flexible burnishing tool should be used. This consists of a flexible strip of metal with an etched roughened surface, resembling in effect a superfine file. The polishing action is so delicate that no scratches are left, yet corroded material will be removed rapidly and thoroughly. The flexibility of the tool insures the cleaning of the actual points of contact.

Silver contacts should not be cleaned with knives, files or abrasive paper or cloth. Knives or files may leave scratches which increase arcing and deterioration of the contacts. Abrasive paper or cloth may leave minute particles of insulating abrasive material in the contacts thus preventing contact closing.

The burnishing tool described above can be obtained from the factory.

#### RENEWAL PARTS

It is recommended that sufficient quantities of renewal parts be carried in stock to enable the prompt replacement of any that are worn, broken, or damaged.

When ordering renewal parts, address the nearest Sales Office of the General Electric Company, specify quantity required, name of part wanted, and give complete nameplate data. If possible, give the General Electric Company requisition number on which the relay was furnished. Refer to Renewal Parts Publication GEF-4086.

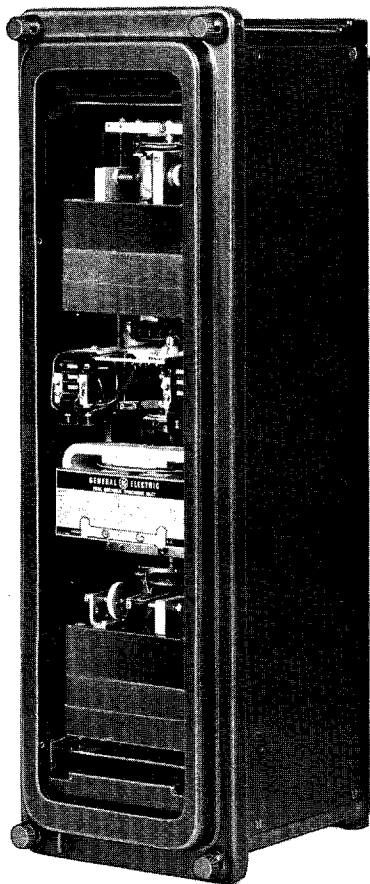

FIG. 1 (8023337) Type JBC53L Relay Removed From Case



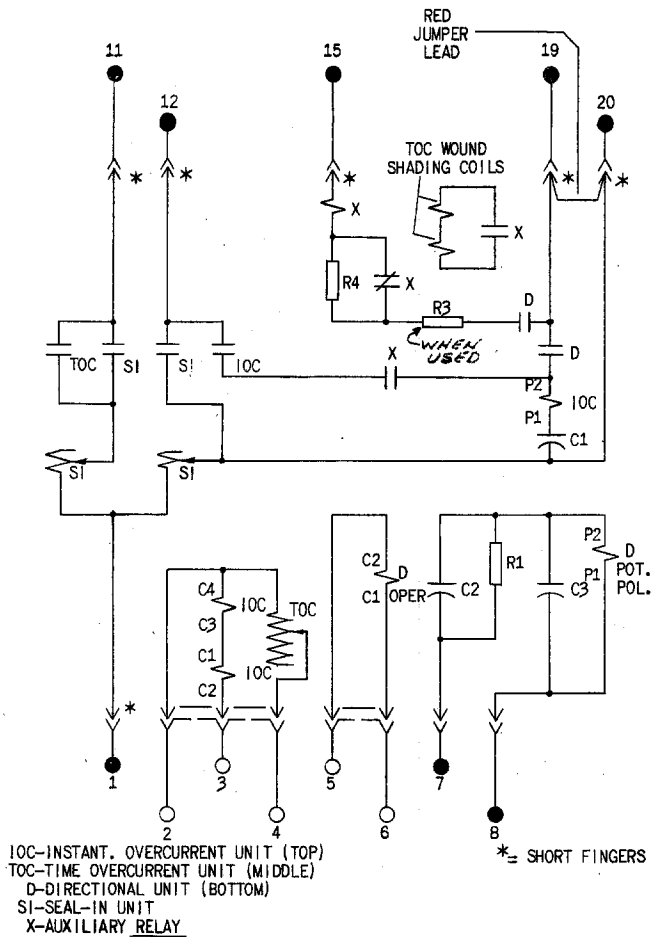

FIG. 2 (418A859-3 SH. 1) Internal Connections For Type JBC53L Relay

DC VOLTAGE RATING	RESISTANCE - OHMS		
	X UNIT COIL	R3	R4
48	10	50	100
125	58	300	1700

FIG. 2 (418A859-0 SH. 2) Internal Connections For Type JBC53L Relay

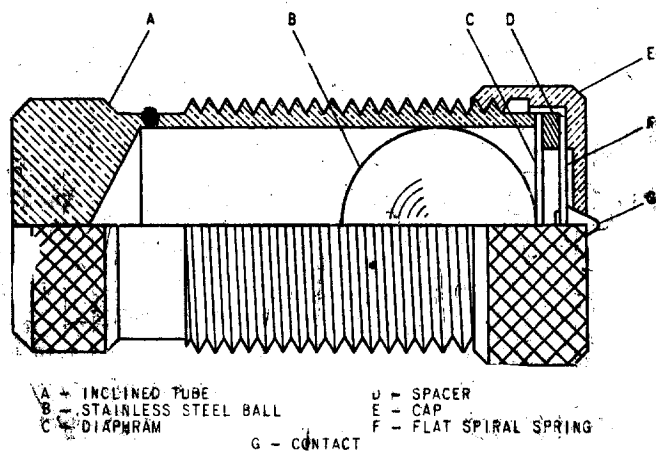

FIG. 3 (K-6077069-3) Barrel Contact Assembly For The Directional And Instantaneous Overcurrent Units

GEK-41989

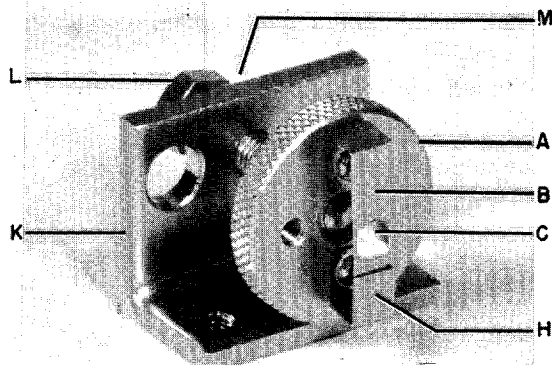

FIG. 4 (8027689) Low Gradient Contact Assembly For The Directional Unit

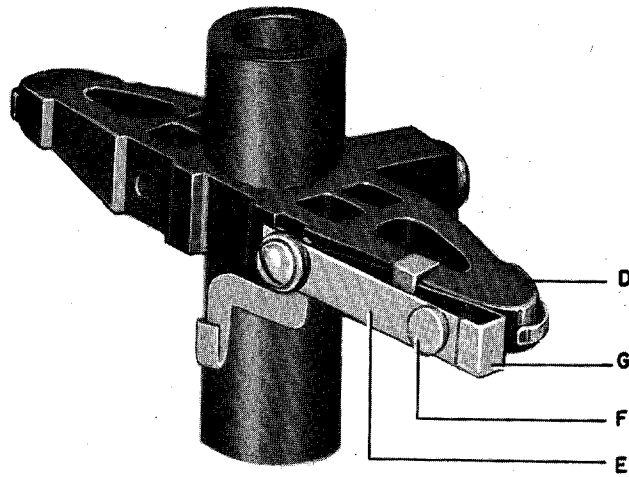
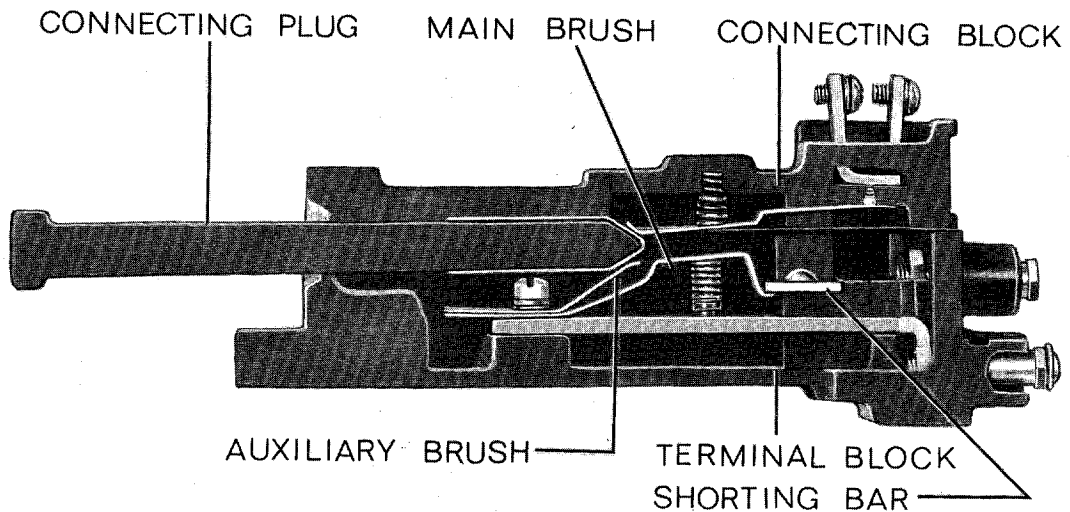

FIG. 4 (8023399) Low Gradient Contact Assembly For The Directional Unit



NOTE: AFTER ENGAGING AUXILIARY BRUSH, CONNECTING PLUG TRAVELS  $\frac{1}{4}$  INCH BEFORE ENGAGING THE MAIN BRUSH ON THE TERMINAL BLOCK

FIG. 5 (8025039) Cross Section Of Drawout Case Showing Position Of Auxiliary Brush

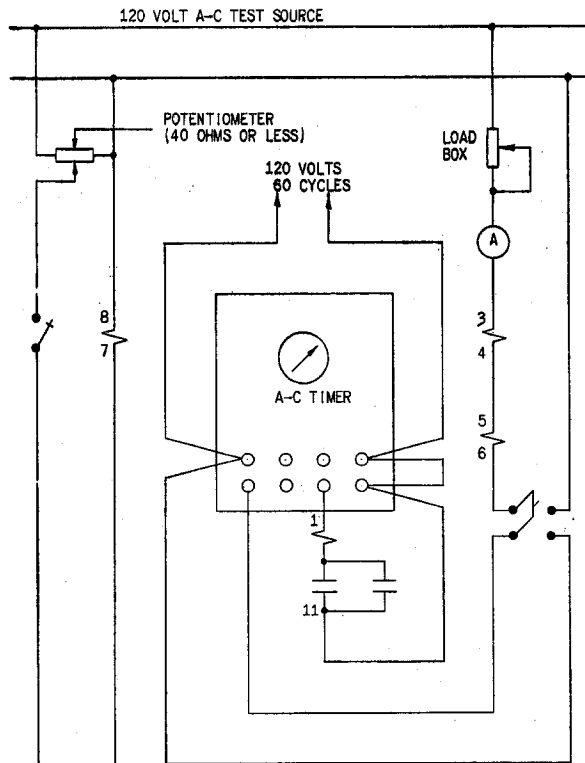
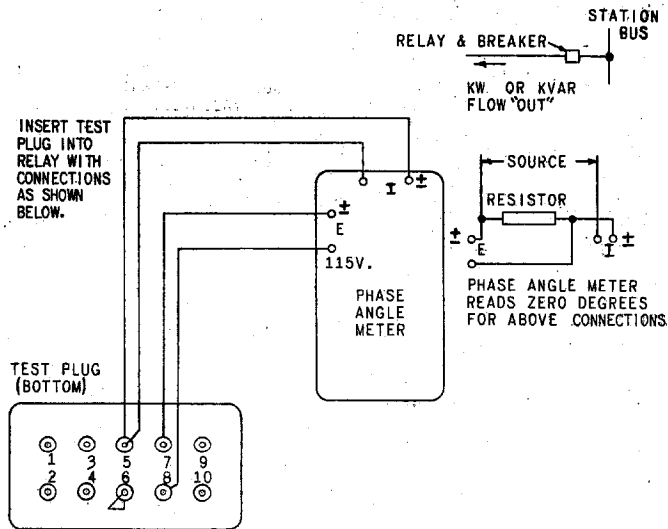

FIG. 6 (418A973-0) Test Connections For Checking Pickup And Operating Time Of The Time Overcurrent Unit



POWER FACTOR ANGLE (DEG. LEAD)	0-45	45-90	90-135	135-180	180-225	225-270	270-315	315-360
KW & KVAR DIRECTIONS WITH RESPECT TO THE BUS	KW OUT > KVAR IN	KVAR IN > KW OUT	KVAR IN > KW IN	KW IN > KVAR IN	KVAR OUT > KW IN	KW OUT > KVAR IN	KVAR OUT > KW OUT	KW OUT > KVAR OUT
METER READING WITH PROPER EXT. CONNS.	90-135	135-180	180-225	225-270	270-315	315-360	0-45	45-90

THE ABOVE RANGES OF PHASE ANGLE METER READINGS ARE THE ANGLES BY WHICH THE CURRENT LEADS THE VOLTAGE WITH THE DESCRIBED CONDITIONS OF POWER (KW) AND REACTIVE POWER (KVAR) FLOW WITH THE STATION BUS CONSIDERED AS THE REFERENCE IN ALL CASES. > MEANS GREATER THAN. CAUTION: MAKE CORRECTIONS FOR METER ERRORS ON LOW CURRENTS, INHERENT IN SOME PHASE-ANGLE METERS.

FIG. 7 (377A195-3) Test Connections For Checking Polarity Of The External Wiring To The Directional Unit

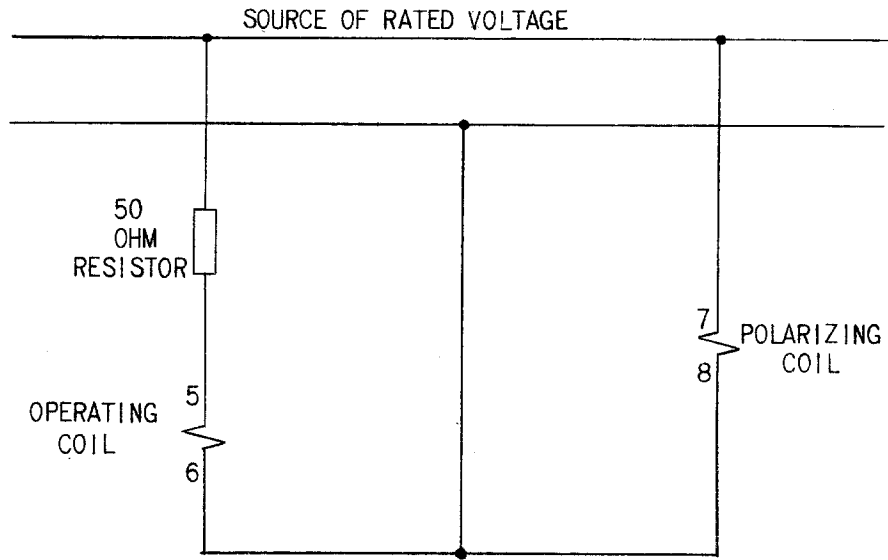

NOTE: THE DIRECTIONAL UNIT CONTACTS SHOULD CLOSE WHEN THE RELAY IS ENERGIZED WITH THE ABOVE CONNECTIONS.

FIG. 8 (418A970-0) Test Connections For Checking Polarity Of The Directional Unit Internal Wiring

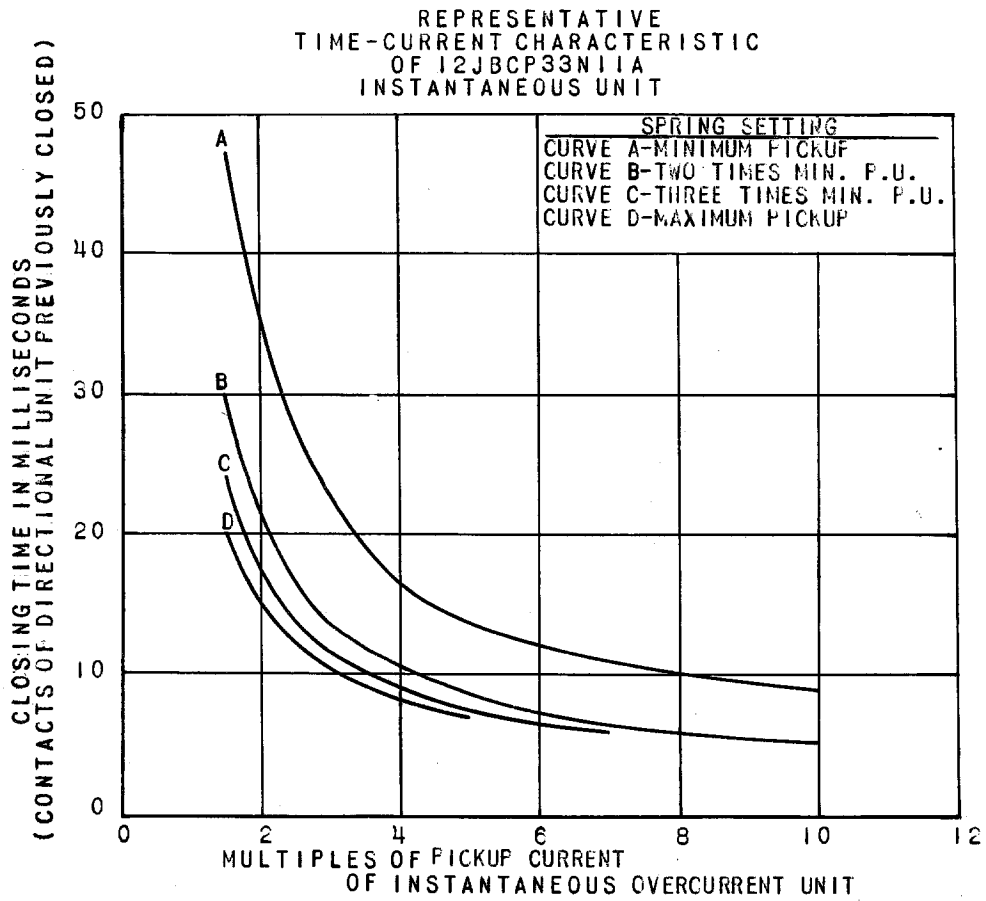

FIG. 9 (K-6556439-2) Instantaneous Overcurrent Unit Time Curve

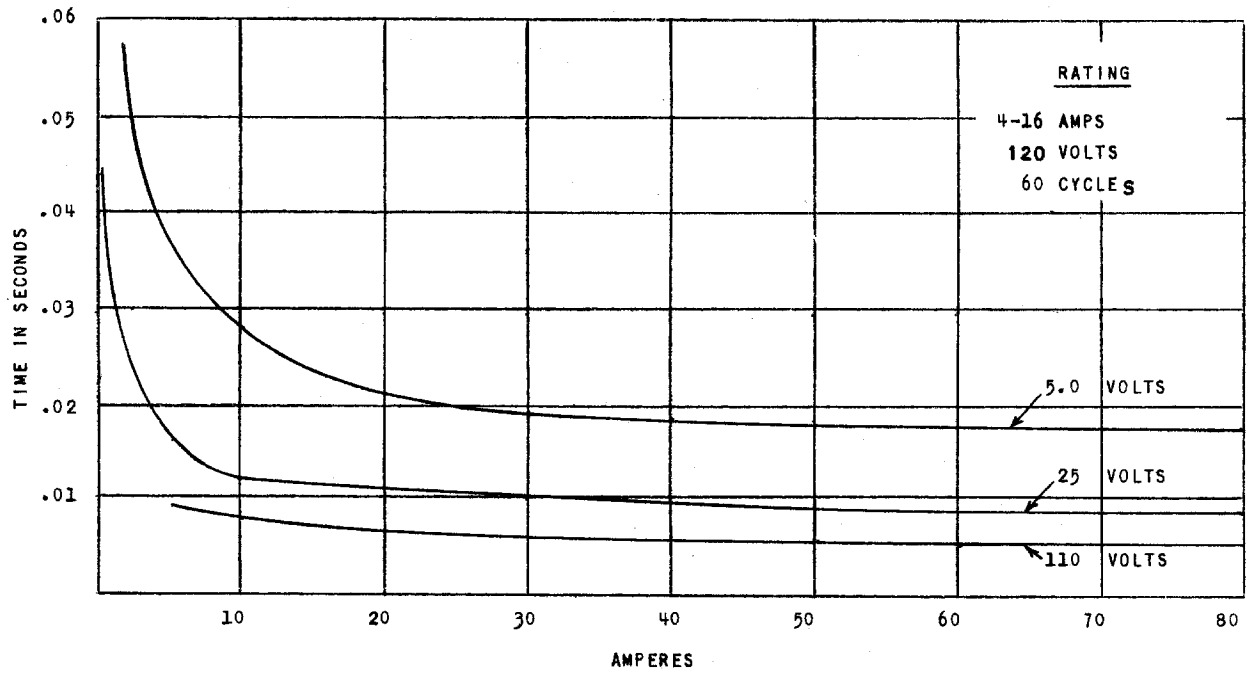

FIG. 10 (K-6154284-2) Directional Unit Time Curve (1.5/6 Ampere Range) For Voltage Applied In Phase With Current

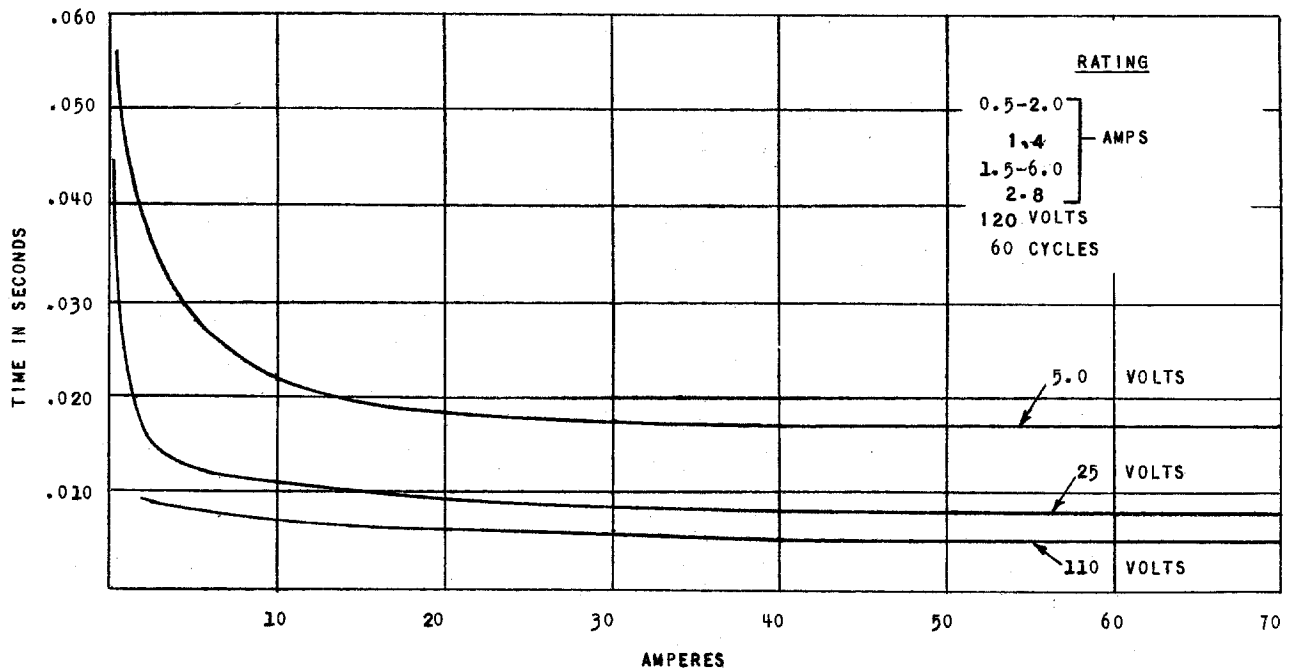

FIG. 11 (K-6154283-2) Directional Unit Time Curve (4/16 Ampere Range) For Voltage Applied In Phase With Current

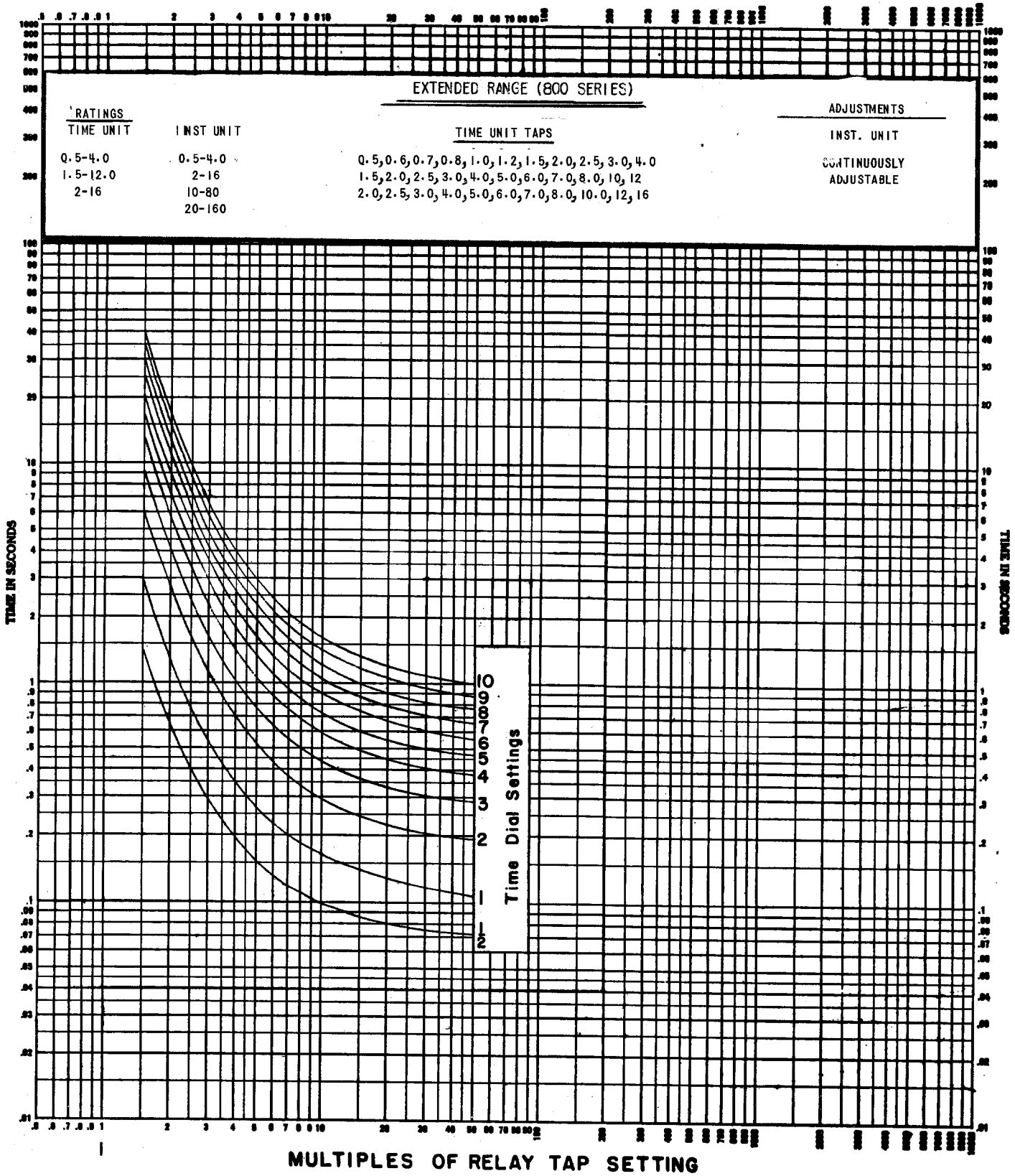

FIG. 12 (0888B0270-2) Time Current Curves For Very Inverse Time Overcurrent Unit

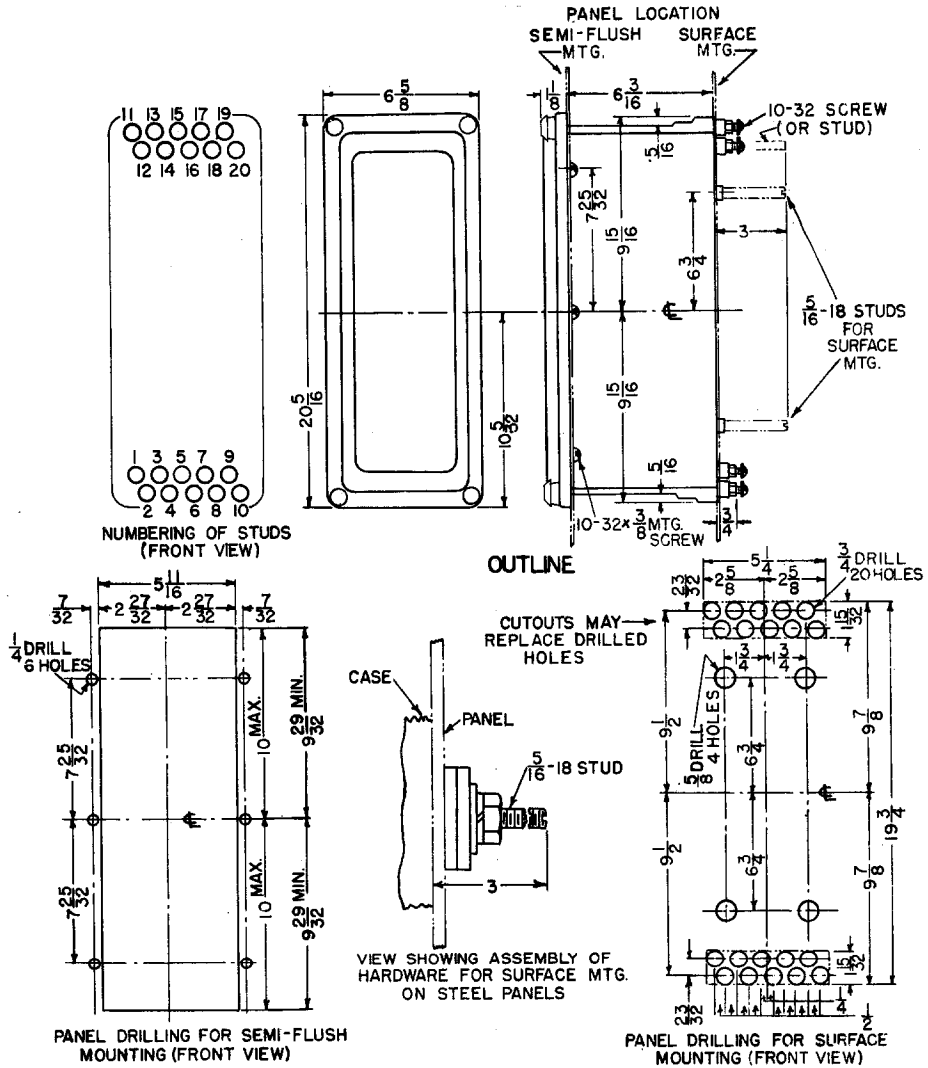

FIG. 13 (K-6209276-1) Outline And Panel Drilling Dimensions For JBC Relays

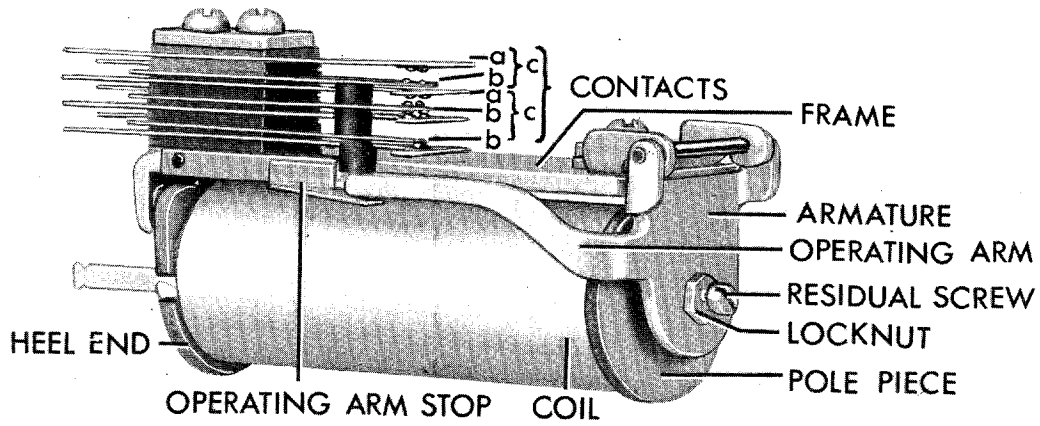

FIG. 14 (8012106) Typical Telephone Relay Type Auxiliary Unit Used In JBC53L Relay

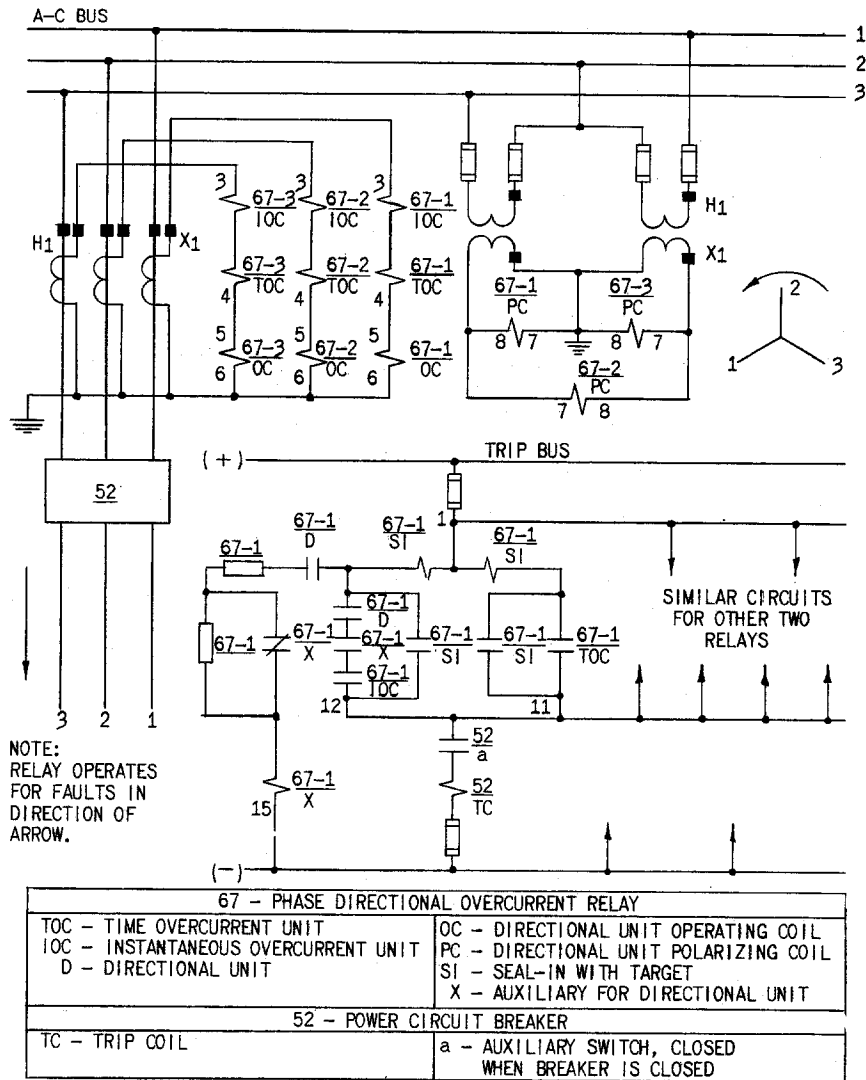

FIG. 15 (418A963-0) Quadrature Connections Of Three Single-Phase Type JBC53L Relays For Directional Phase Fault Protection Of A Transmission Line