

INSTRUCTIONS

GEI-83946

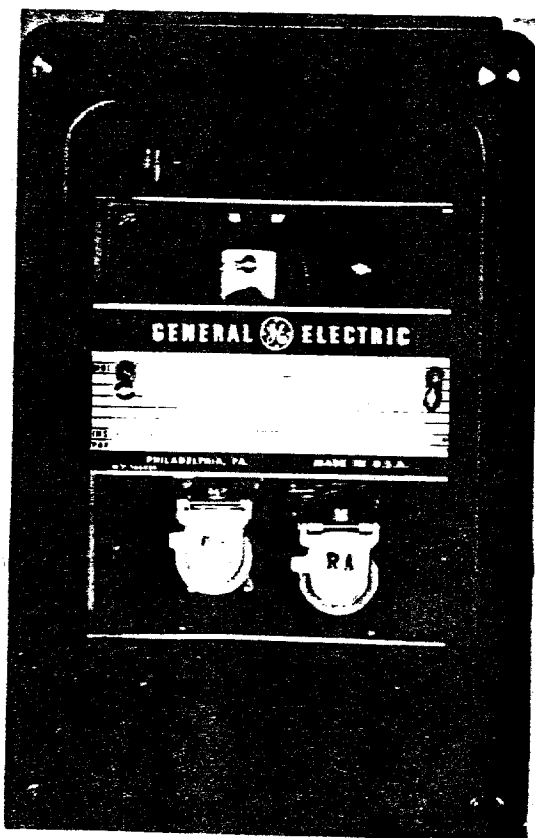

CARRIER AUXILIARY RELAY NAA22L



POWER SYSTEMS MANAGEMENT DEPARTMENT

GENERAL  ELECTRIC

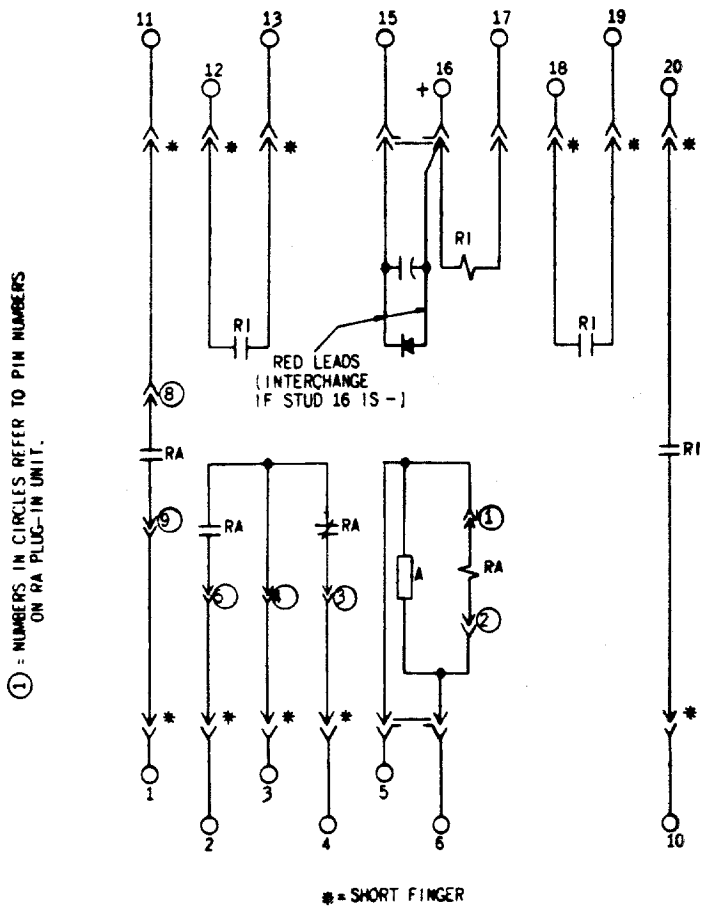

Fig. 1 (0148A4074-0 Shs. 1 & 2) Internal Connections (Front View for the NAA22L Relay)

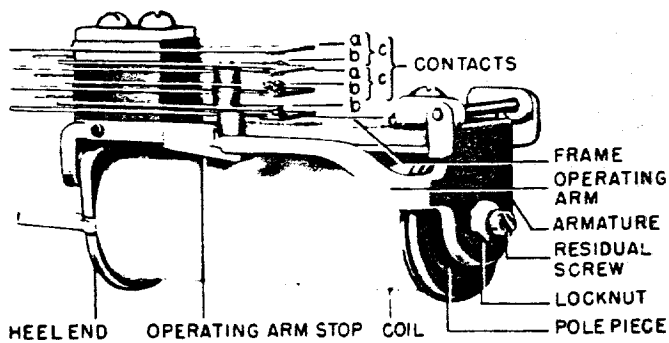
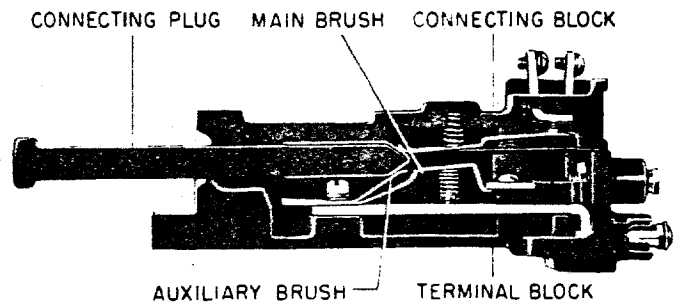

Fig. 2 (8012106) Typical Telephone-relay Unit Used in Type NAA Relays



NOTE: AFTER ENGAGING AUXILIARY BRUSH, CONNECTING PLUG TRAVELS 1/4 INCH BEFORE ENGAGING THE MAIN BRUSH ON THE TERMINAL BLOCK.

Fig. 3 (8025039) Cross Section of Drawout Case Showing Position of Auxiliary Brush

CARRIER AUXILIARY RELAY

TYPE NAA22L

DESCRIPTION

The NAA22L relays covered by this instruction book are auxiliary relays used in directional comparison pilot relaying systems. They consist of telephone-type relays which are functionally indicated as RA and RI (described below), and a tripping rectifier housed in a size S-2 draw-out case.

APPLICATION

NAA22L relays are used only with BC11AV relays, as auxiliary relays in directional comparison relaying involving CS-27 carrier.

The RI unit is normally connected to the instantaneous trip bus. It is used to initiate high-speed reclosing following an instantaneous trip, and to hold off carrier at the line terminal which trips first in cases where there is a difference in tripping time at opposite ends of a line. The tripping rectifier associated with the RI coil is used to separate the instantaneous and delayed trip buses.

The RA coil is connected in series with the BCA receiver relay coil, and is energized from the carrier receiver. RA unit contacts energize a bell and a lamp, for telephone calling. They may also be used for impulse-duration telemetering with a 5-second cycle.

Selection of a given form depends on the d-c control voltage and the type of carrier-current receiver used.

RATINGS

The NAA relays covered by these instructions are available with potential circuits rated for 48, 125, and 250 volts DC. Telephone relay contacts will make and carry 30 amperes for tripping duty. The interrupting capabilities for each contact are listed below.

CONTACT INTERRUPTING ABILITY

Volts	Interruption Cur. (Amps)	
	Inductive *	Non-Inductive
48 - DC	1.0	3.0
125 - DC	0.5	1.5
250 - DC	0.25	0.75
115 - 60 Cy.	0.75	2.0
230 - 60 Cy.	0.5	1.0

* Inductance of Average Trip Coil

CHARACTERISTICS

PICKUP AND DROPOUT

The RA unit is adjusted to pick up between .130 and .150 amperes and drop out between .045 and .065 amperes.

The RI unit is adjusted to pick up at 70 percent or less of rated voltage. Pickup time at rated voltage is less than 16 milliseconds; dropout time will be 115 to 167 milliseconds.

BURDENS

Resistance and capacitance values of circuit components are listed on the internal connection diagram.

CONSTRUCTION

BASIC RELAY UNIT

These relays are assembled with telephone-relay units of hinged armature construction (see Fig. 2) mounted in a drawout case. The RA unit is mounted on a plug-in base.

CASE

The units of each relay are mounted on a cradle assembly which can be easily removed from the relay case. The cradle is locked in the case by means of latches at the top and bottom. The electrical connections between the case and cradle block are completed through a removable connection plug. A separate testing plug can be inserted in place of the connection plug to permit testing the relay in its case. The cover attaches to the case from the front and includes the target reset mechanism and an interlock arm to prevent the cover from being replaced until the connection plug has been inserted.

The case is suitable for either semi-flush or surface mounting on panels up to two inches thick. Hardware is available for all panel thickness up to two inches, but panel thickness must be specified on the order to insure that the proper hardware will be provided. Outline and panel drilling dimensions are shown in Fig. 6.

RECEIVING, HANDLING AND STORAGE

These relays, when not included as a part of a control panel, will be shipped in cartons designed to protect them against damage. Immediately upon receipt of a relay, examine it for any damage sustained in transit. If injury or damage resulting from rough handling is evident, file a

damage claim at once with the transportation company and promptly notify the nearest General Electric Apparatus Sales Office.

Reasonable care should be exercised in unpacking the relay. If the relays are not to be installed immediately, they should be stored in their original cartons in a place that is free from moisture, dust, and metallic chips. Foreign matter collected on the outside of the case may find its way inside when the cover is removed and cause trouble in the operation of the relay.

ACCEPTANCE TESTS

Immediately upon receipt of the relay an INSPECTION AND ACCEPTANCE TEST should be made to insure that no damage has been sustained in shipment and that the relay calibrations have not been disturbed. If the examination or test indicates that readjustment is necessary, refer to the section on SERVICING.

VISUAL INSPECTION

Check the nameplate stamping to insure that the model number and rating of the relay agree with the requisition.

Remove the relay from its case and check that there are no broken or cracked molded parts or other signs of physical damage, and that all screws are tight.

MECHANICAL INSPECTION

It is recommended that the following mechanical adjustments be checked:

1. With telephone relays in the de-energized position all circuit closing contacts should have a gap of 0.015" and all circuit opening contacts have a wipe of 0.005". Gap may be checked by inserting a feeler gage and wipe can be checked by observing the amount of deflection on the stationary contact before parting the contacts. The armature should then be operated by hand and the gap and wipe again checked as described above.

2. Check the positions of the connection brushes on the cradle block and the case block against internal connection diagram for the relay. Be sure that the shorting bars are in the proper positions on the case block and that the long and short brushes on the cradle block agree with the internal connection diagram. Fig. 3 shows a sectional view of the case and cradle blocks in place. Note that there is an auxiliary brush in each position on the case block. This brush should be bent high enough so that when the connection plug is inserted

These instructions do not purport to cover all details or variations in equipment nor to provide for every possible contingency to be met in connection with installation, operation or maintenance. Should further information be desired or should particular problems arise which are not covered sufficiently for the purchaser's purposes, the matter should be referred to the General Electric Company.

its contact strips engage the auxiliary brushes before striking the main brush. This is especially important in current circuits and other circuits with shorting bars since an improper adjustment of the auxiliary brush may result in a momentary open circuit.

ELECTRICAL TESTS

It is recommended that the following electrical tests be made immediately upon receipt of the relay. Note that all tests should be made with relay in its case and connection plug inserted.

1. Test pickup of RA and RI. For test connections see Fig. 4.

2. Test pickup and dropout time of RI unit. For test connections see Fig. 4.

The RA unit has been adjusted to pick up between .130 and .150 amperes and drop out between .045 and .065 amps.

The RI unit has been adjusted to pick up at 70 percent or less of rated voltage. Pickup time at rated voltage should be less than 16 milliseconds and dropout time 115 to 167 milliseconds.

INSTALLATION PROCEDURE

If after the ACCEPTANCE TESTS the relay is held in storage before shipment to the job site, it is recommended that the visual and mechanical inspection described under the section on ACCEPTANCE TESTS be repeated before installation.

Before any of the following electrical tests are made the relay should be in its case, preferably mounted in its permanent

locations. Repeat pickup tests described under the section on ACCEPTANCE TESTS using a tenpoint test plug as shown in Fig. 5.

PERIODIC CHECKS AND ROUTINE MAINTENANCE

In view of the vital role of protective relays in the operation of a power system it is important that a periodic test program be followed. It is recognized that the interval between periodic checks will vary depending upon environment, type of relay, and the users experience with periodic testing. Until the user has accumulated enough experience to select the test interval best suited to his individual requirements, it is suggested that the following points be checked at an interval of from one to two years.

MECHANICAL CHECKS

Check the telephone relay contacts for 0.015" gaps and 0.005" wipe as described under the section on ACCEPTANCE TESTS.

ELECTRICAL CHECKS

Connect the relay as shown in Fig. 5 and repeat the tests described under the section on ACCEPTANCE TESTS.

SERVICING

If any of the mechanical or electrical check points described in the previous sections are found to be out of limits, the following points should be observed in restoring them:

MECHANICAL

1. Telephone relay contact gaps may be adjusted by bending the stationary contact

brush to obtain 0.015" gap. When the adjustments is made, the wipe of the circuit closing contacts should be checked to be 0.005" and wipe adjustment can be made by bending the moving contact brush as required.

ELECTRICAL

1. To decrease the voltage or current at which the telephone relay will pick up, decrease the gap between the armature and the pole face by bending the contact operating arm stop. To increase the pickup, reverse the above procedure. After this adjustment is made it will be necessary to readjust the contacts to obtain a wipe of 0.005" and a gap of 0.015". Resetting the circuit opening contact pressure can also alter the percentage pickup.

2. To decrease pickup time reduce the pressure of the circuit opening contacts by bending the moving flexible contact. To increase the pickup time reverse the above procedure.

RENEWAL PARTS

It is recommended that sufficient quantities of renewal parts be carried in stock to enable the prompt replacement of any that are worn, broken, or damaged.

When ordering renewal parts, address the nearest Sales Office of the General Electric Company, specify quantity required, name of part wanted, and give complete nameplate data, including serial number. If possible, give the General Electric Company requisition number on which the relay was furnished.

(A) CURRENT PICKUP TEST

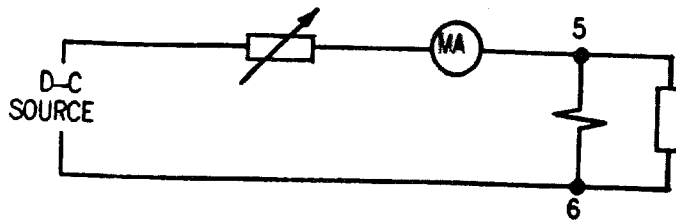

(B) VOLTAGE PICKUP TEST

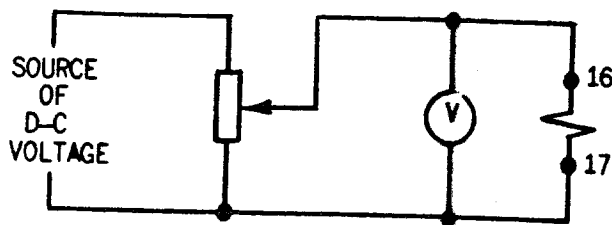

(C) TIME TEST FOR RI UNIT VOLTAGE

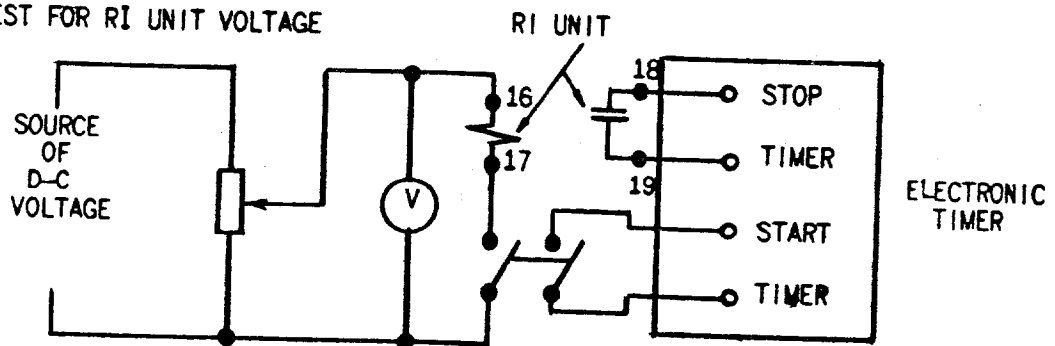
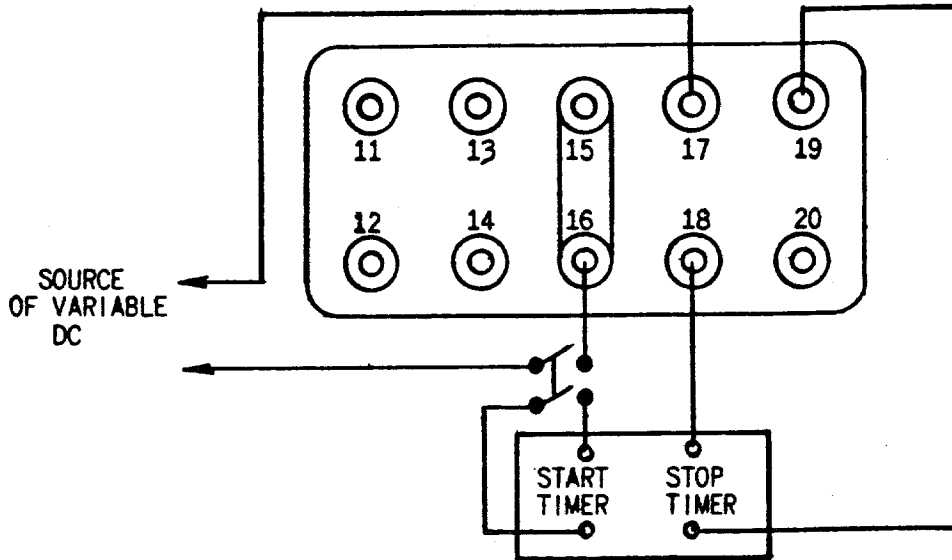
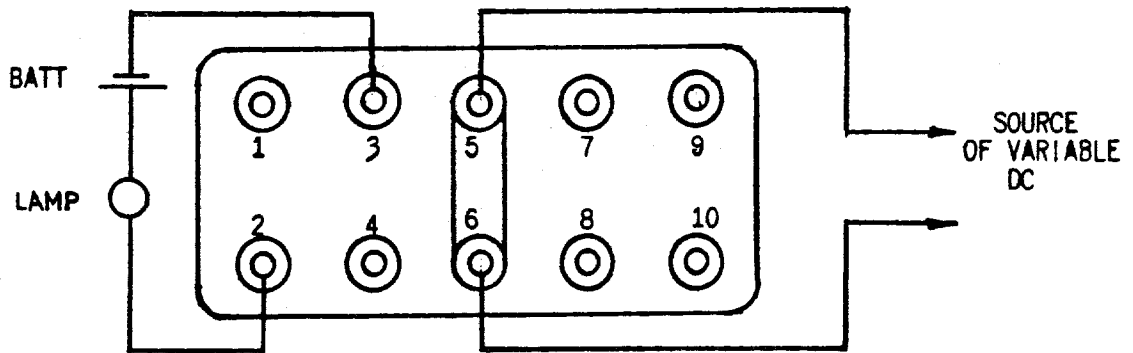

Fig. 4 (01484092-0) Laboratory Test Connections for the NAA22L Relay



RI PICKUP TIME TEST
FOR DROPOUT TIME REVERSE LEADS TO START AND STOP



RA PICKUP AND DROPOUT TEST

Fig. 5 (0148A4091-0) Field Test Connections for the NAA22L Relay

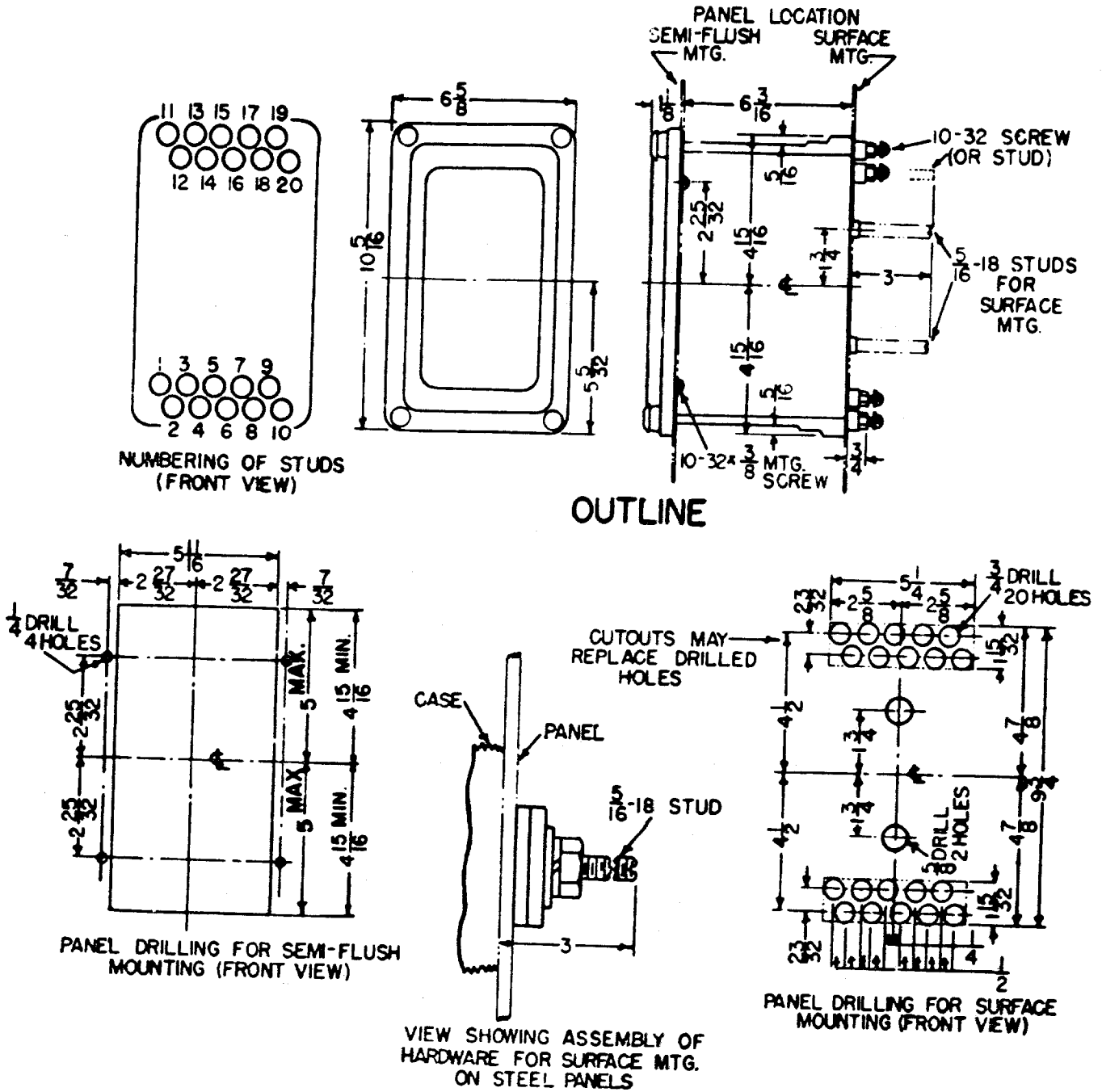

Fig. 6 (6029272-2) Outline and Panel Drilling Dimensions for Type NAA22L Relays



GE Power Management

215 Anderson Avenue
Markham, Ontario
Canada L6E 1B3
Tel: (905) 294-6222
Fax: (905) 201-2098
www.GEindustrial.com/pm