



INSTRUCTIONS

UNDERVOLTAGE RELAYS

TYPES

NGV11A - Forms 11 and up
NGV11B - Forms 11 and up
NGV12A - Forms 11 and up
NGV12B - Forms 11 and up
NGV12C - Forms 11 and up
NGV13A - Forms 21 and up
NGV13B - Forms 21 and up

*GE Meter and Control
205 Great Valley Parkway
Malvern, PA 19355-0715*

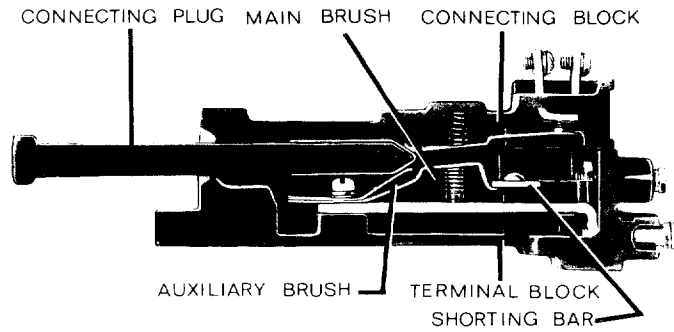

NOTE: AFTER ENGAGING AUXILIARY BRUSH CONNECTING PLUG TRAVELS $\frac{1}{4}$ INCH BEFORE ENGAGING THE MAIN BRUSH ON THE TERMINAL BLOCK

Figure 1 (8025039) Cross Section of Drawout Case Showing Position of Auxiliary Brush

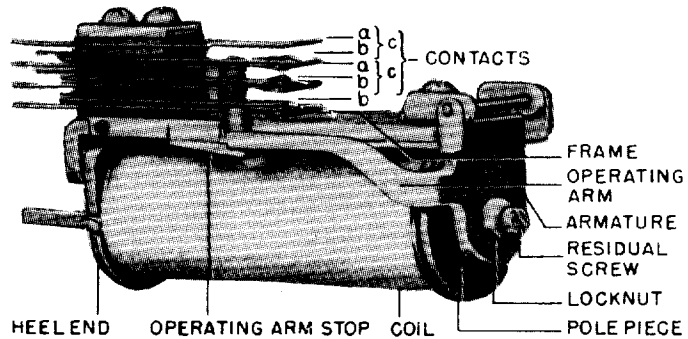

Figure 2 (8012106) Typical Telephone Type Unit Used in NGV Relays

**UNDervOLTAGE RELAYS
TYPE NGV**

DESCRIPTION

The NGV relay is a high-speed relay designed to be used wherever undervoltage protection is required. The relay is designed to operate continuously picked up at its rated voltage if required. The different models available are listed in Table A.

TABLE A
NGV RELAY MODELS

Relay	No. of Units in Case	No. of Targets	Type of Case
NGV11A	3	0	S2
NGV11B	3	2	S2
NGV12A	2	0	S2
NGV12B	2	2	S2
NGV12C	2	0	S2
NGV13A	1	0	S1
NGV13B	1	1	S1

The relay undervoltage element consists of a telephone-type relay in series with a zener regulator connected across a full wave rectifier. A capacitor is connected across the rectifier AC supply to protect the rectifier from severe voltage surges. A rheostat is connected in series with the rectifier to provide pickup adjustment. Targets mounted in the drawout case are available as indicated in Table A. The outline and drilling dimensions of the relay are depicted in Figures 10 and 11.

APPLICATION

The NGV relay is intended for general application wherever instantaneous detection of undervoltage is required. Some specific applications are listed below:

1. Instantaneous undervoltage detection for preferred-emergency throwover control equipment.
2. Ground fault detection for faulted-phase selection on ungrounded systems.
3. Phase fault detection for disabling telephone or telemetering services at stations with weak backfeed on carrier channels used for relaying.

These instructions do not purport to cover all details or variations in equipment nor to provide for every possible contingency to be met in connection with installation, operation or maintenance. Should further information be desired or should particular problems arise which are not covered sufficiently for the purchaser's purposes, the matter should be referred to the General Electric Company.

To the extent required the products described herein meet applicable ANSI, IEEE and NEMA standards; but no such assurance is given with respect to local codes and ordinances because they vary greatly.

RATINGS

The NGV relay potential units available are rated at 69 to 240 volts, 50/60 cycles.

The contacts will make and carry 30 amperes for tripping duty. The interrupting capabilities for each contact for repetitive protective duty are given in Table B.

The target units are current operated and have a minimum operating rating of 0.2 amperes or 2.0 amperes.

The contacts which are not in series with target coils will carry three amperes continuously.

TABLE B
CONTACT INTERRUPTING ABILITY

Volts	Interruption Capability (Amps) Inductive**
48 DC	1.0
125 DC	0.5
250 DC	0.25
115 - 60 cycles	0.75
230 - 60 cycles	0.5

**Inductance of average trip coil. The non-inductive ratings for repetitive protective duty are approximately 2-1/2 times ratings shown in the table.

CHARACTERISTICS

The NGV voltage unit is a hinged armature unit which drops out when the magnetic pull created by the ampere-turns in the operating coil is less than the force of the opening spring. The drop-out voltage is changed by adjusting the rheostat and the voltage range is given in Table C.

TABLE C
VOLTAGE RANGE

Rated Volts	Range of Dropout Adjustment
69	40 - 58
120	70 - 100
208	121 - 173
240	140 - 200

The pickup voltage is 110 percent or less of the dropout voltage. On any dropout operation, the voltage range from the beginning of the action to its completion is about one percent of rated voltage.

The relay pickup time is approximately two cycles and the dropout characteristic (voltage against time) is shown in Figure 9.

The burden of the voltage unit is at unity power factor and the values are given in Table D.

TABLE D
BURDENS

Rated Voltage	Maximum Burden, Watts
69	4
120	4.2
208	4.75
240	4.5

The target unit coil has a DC resistance of 7.5 ohms for the 0.2 ampere unit and 0.12 ohms for the 2 ampere unit.

Internal connections of the various relays are shown in Figures 3 through 8 and 12.

CONSTRUCTION

The relay components are mounted in a cradle assembly which is latched into a drawout case when the relay is in operation, but that can be easily removed when desired. To remove the relay from its case, first disconnect it by removing the connection plug that completes the electrical connections between the case block and the cradle block. This connection block can be replaced by a test plug to test the relay in its case. The cover, which is attached to the front of the relay case, contains the target reset mechanism and an interlock arm which prevents the cover from being replaced until the connection plugs have been inserted.

The relay case is suitable for either semi-flush or surface mounting on all panels up to two inches thick; appropriate hardware is available. However, to insure that proper hardware will be included, panel thickness must be indicated on the relay order. For outline and drilling dimensions, see Figures 10 and 11. Every circuit in the drawout case has an auxiliary brush, as shown in Figure 1, to provide adequate overlap when the connecting plug is withdrawn or inserted. Some circuits are equipped with shorting bars (see Figures 3-8) and on these circuits, it is especially important that the auxiliary brush makes contact with adequate pressure as indicated in Figure 1 to prevent the opening of interlock circuits.

RECEIVING, HANDLING AND STORAGE

These relays, when not included as part of a control panel, will be shipped in cartons designed to protect them against damage. Immediately upon receipt of a relay, examine it for any damage sustained in transit. If damage resulting from rough handling is evident, file a damage claim at once with the transportation company and promptly notify the nearest General Electric Apparatus Sales Office.

Use reasonable care when unpacking the relays. If the relays are not to be installed immediately, store them in their shipping cartons in a place that is free from moisture, dust and metallic chips. Foreign matter that has collected on the outside of the case could get inside when the cover is removed and cause problems in the operation of the relay.

Also check the nameplate stamping to insure that the model number and the rating of the relay received agree with the requisition. Check the operation manually, and check that the contact gap and wipe agree with values given in the section on **ADJUSTMENTS AND INSPECTION**.

ADJUSTMENT AND INSPECTION

MECHANICAL CHECK

Check the relay for mechanical operation before installation to see that it operates smoothly and that the contacts are correctly adjusted.

With the relay de-energized, each normally open contact should have a gap of 0.015 inch or more. Observe the wipe on each normally closed contact by deflecting the stationary contact member towards the frame. Wipe should be approximately 0.005 inch.

The wipe on each normally open contact should be approximately 0.005 inch. Check by inserting a 0.005 inch shim between the residual screw and the pole piece and operating the armature by hand. The normally open contacts should make before the residual screw strikes the shim.

ELECTRICAL TEST

The relay should be tested before installation and periodically thereafter by connecting a variable source of voltage at rated frequency to the coil studs and checking the pickup and dropout voltages. Use the variable rheostat to the relay, and if necessary, the residual screw to adjust to the values required. Adjustment of the ratio of pickup to dropout is made, if necessary, with the residual screw; in most applications no adjustment of this ratio will be required.

A variable source of DC power should be connected to the target circuits, if furnished, and the pickup amperes checked.

SERVICING

In view of the vital role of protective relays in the operation of a power system it is important to follow a periodic test program. The interval between periodic checks will probably vary depending upon environment, the type of relay and the user's experience with periodic testing. Until the user has accumulated enough experience to select the test interval best suited to individual requirements, the points listed under **ADJUSTMENT AND INSPECTION** should be checked once a year.

A flexible burnishing tool should be used to clean fine silver contacts. This tool is an etched-roughened strip of flexible metal, resembling in effect a superfine file, that will remove corroded material quickly and thoroughly without scratching the surface. The flexibility of the tool insures the cleaning of the actual points of contact. Knives, files, abrasive paper or cloth should never be used to clean fine silver contacts. The burnishing tool described above can be obtained from the factory.

RENEWAL PARTS

Sufficient quantities of renewal parts should be carried in stock for prompt replacement of any parts that become worn, broken, or damaged.

When ordering renewal parts, address the nearest Sales Office of the General Electric Company, specify quantity required, name of the part wanted, and give complete nameplate data. If possible, give the General Electric requisition number on which the relay was furnished.

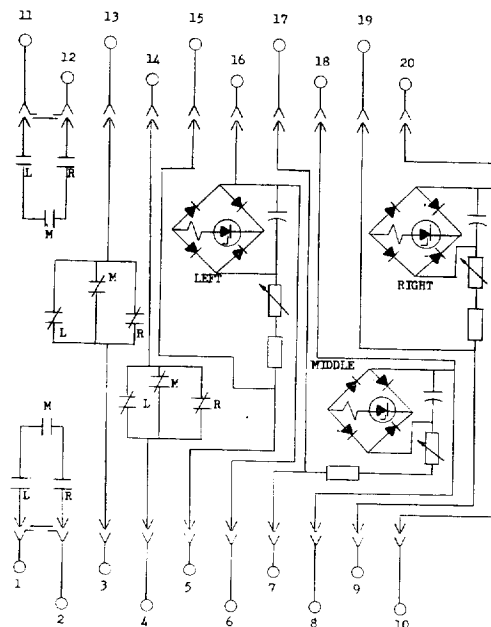

Figure 3 (0195A4938-0) Internal Connections Diagram for the NGV11A Relay (Front View)

GEI-90805

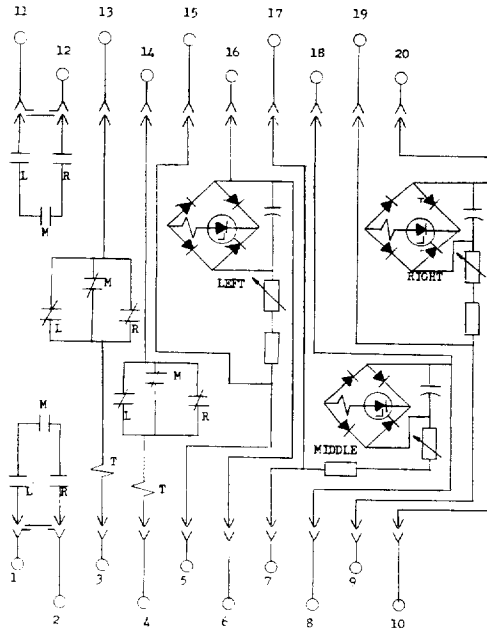

Figure 4 (0195A4939-2) Internal Connections Diagram for the NGV11B Relay (Front View)

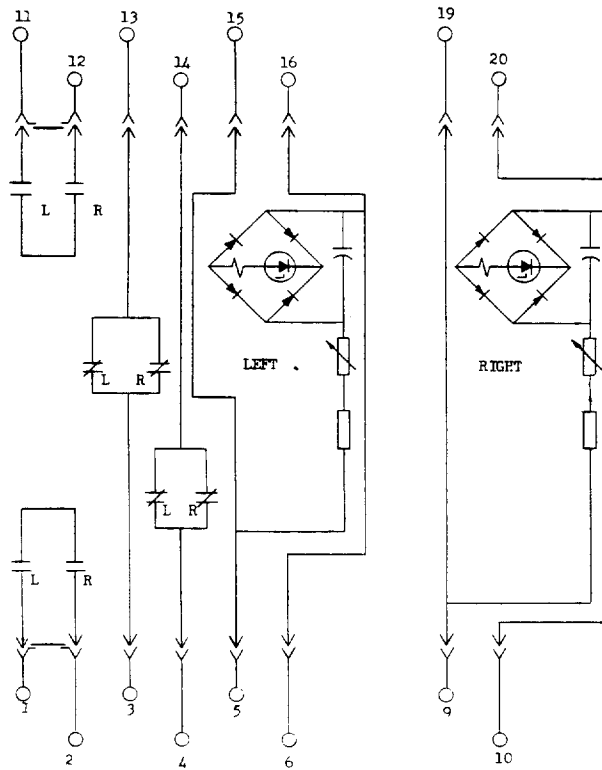

Figure 5 (0178A9182-1) Internal Connections Diagram for the NGV12A Relay (Front View)

GEI-90805

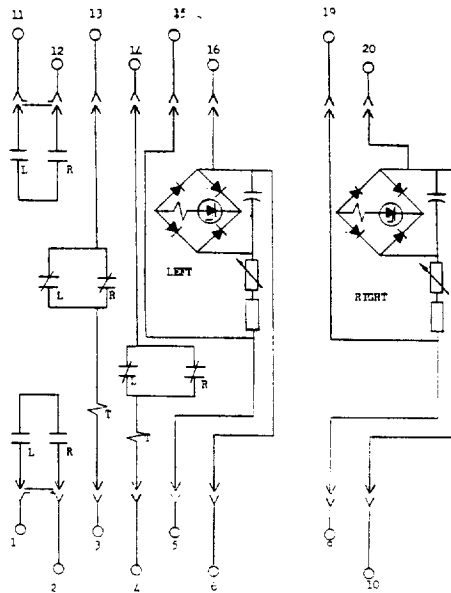
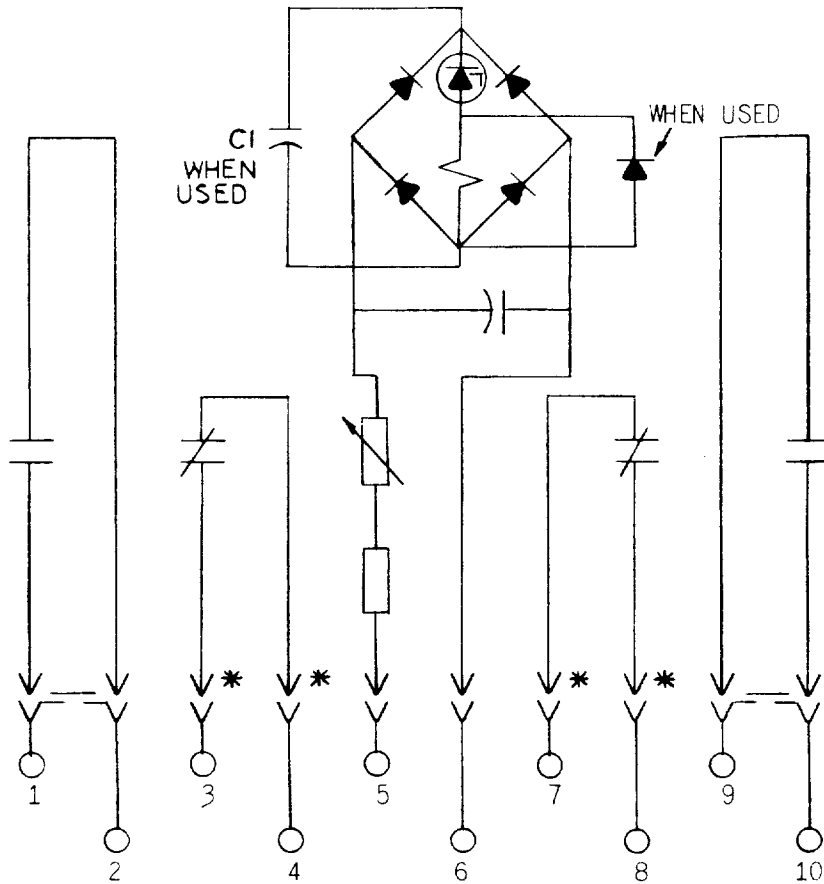

Figure 6 (0195A4956-1) Internal Connections Diagram for the NGV12B Relay (Front View)



* = SHORT FINGER

Figure 7 (0195A4940-4) Internal Connections Diagram for the NGV13A Relay (Front View)

GEI-90805

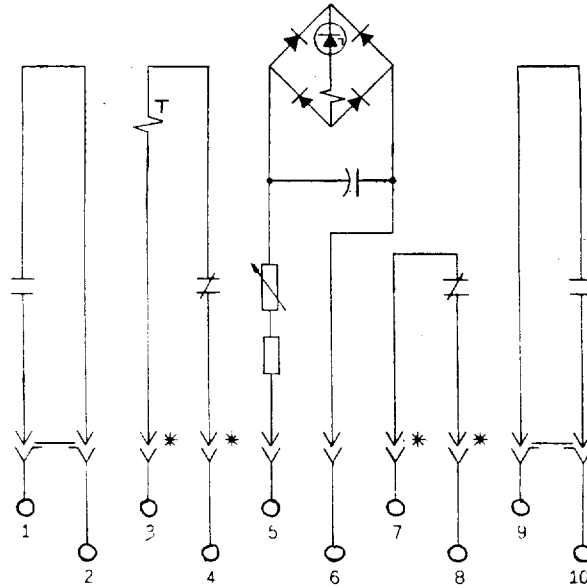

* = SHORT FINGER

Figure 8 (0195A4941-0) Internal Connections Diagram for the NGV13B Relay (Front View)

LINKS SHOWN WITH TARGET IN CIRCUIT 1-2

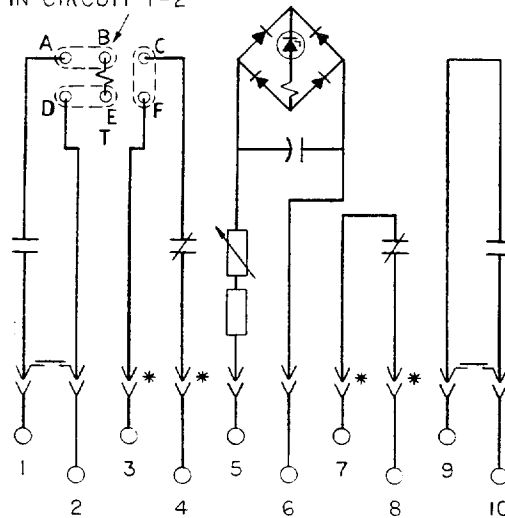

OTHER LINK POSITIONS :-

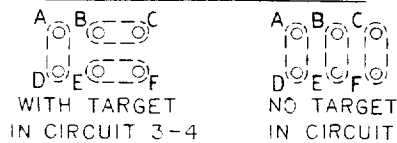

(FRONT VIEW)

* = SHORT FINGERS

Figure 8A (0275A4380-1) Internal Connections Diagram for the NGV13B-Revision A Relay (Front View)

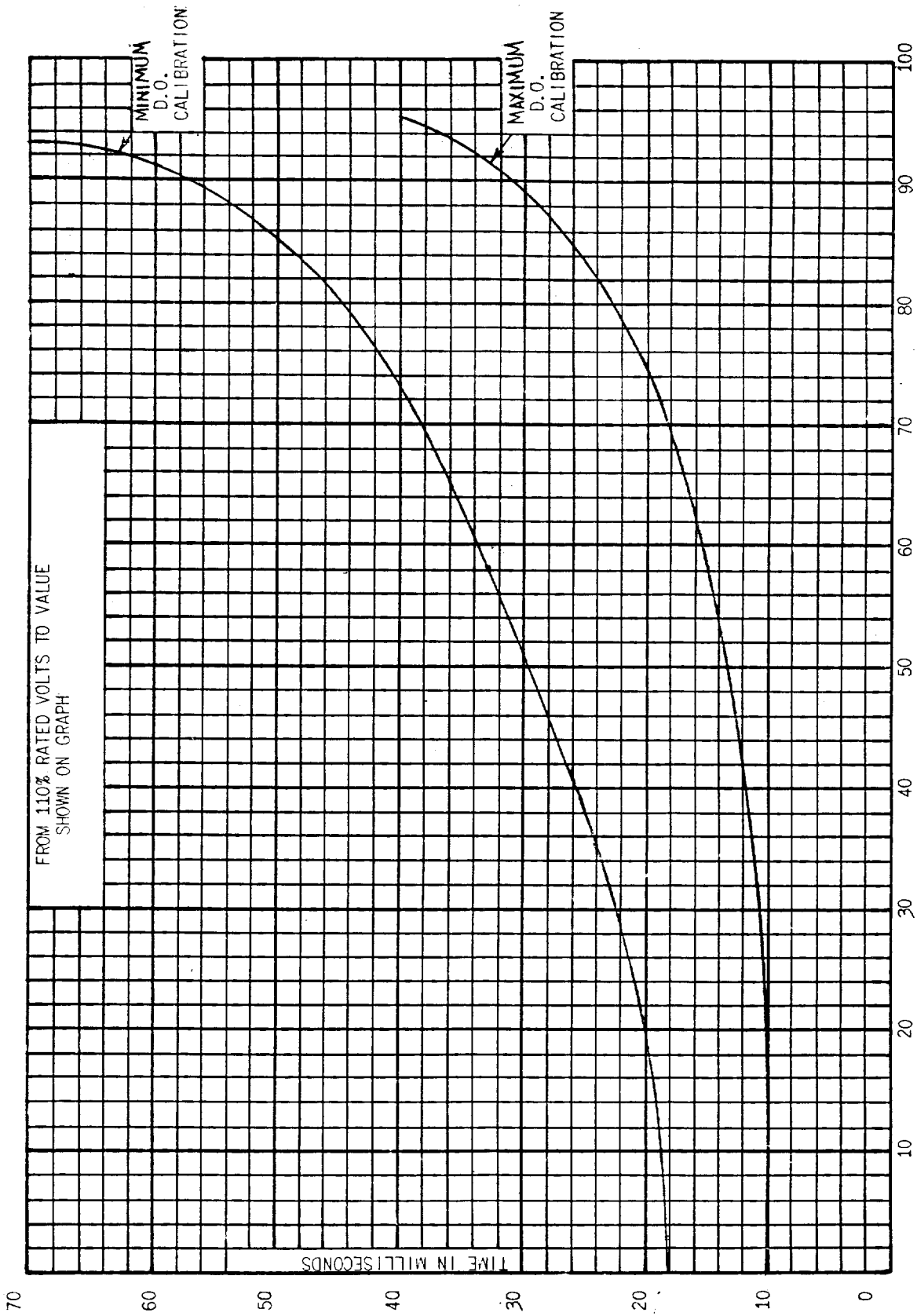

Figure 9 (0165A7560-2) Operating Time Curves for NGV Relays

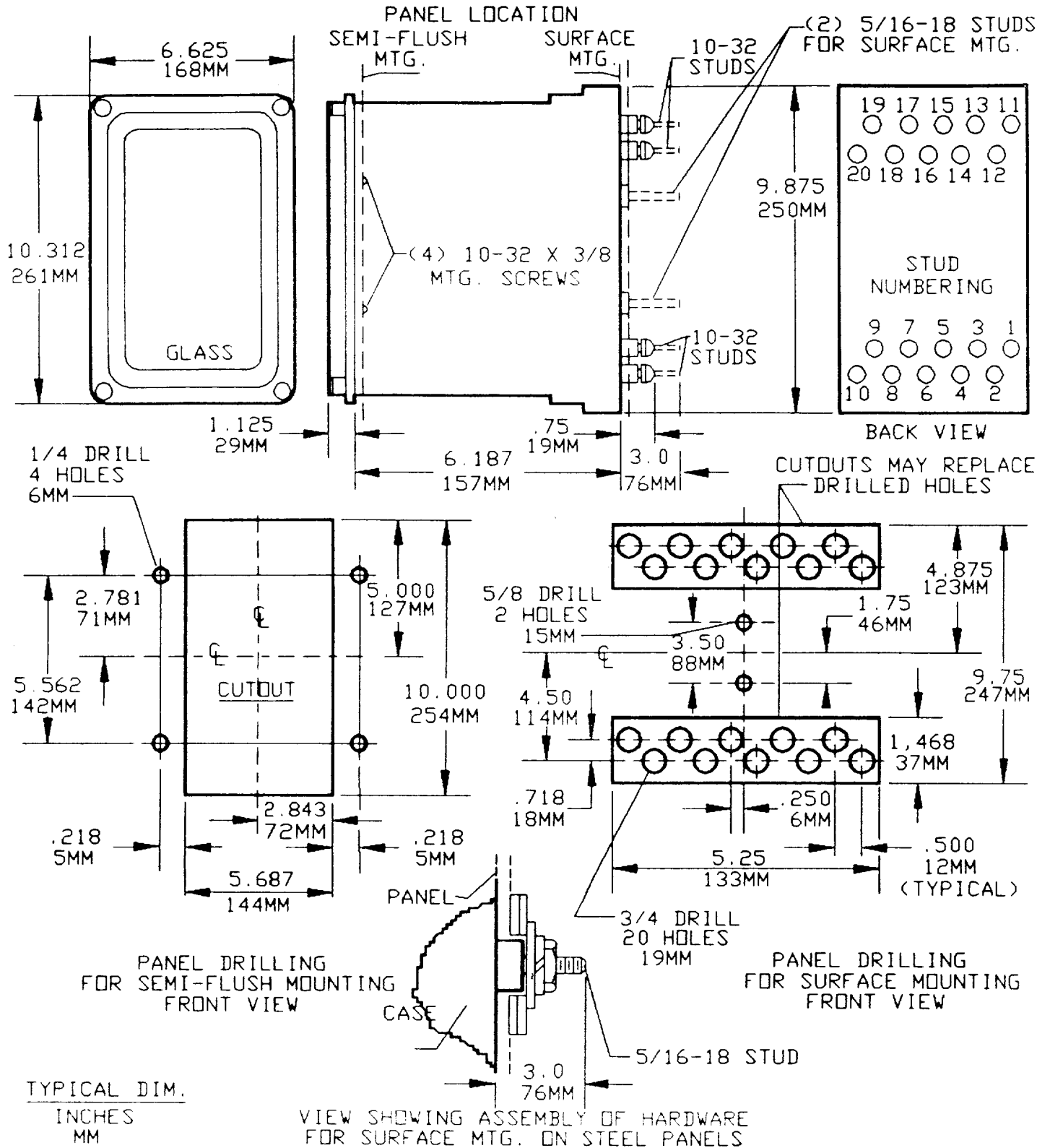

Figure 10 (K-6209272 [7]) Outline and Panel Drilling Dimensions for Drawout Relays - Size S2 Case

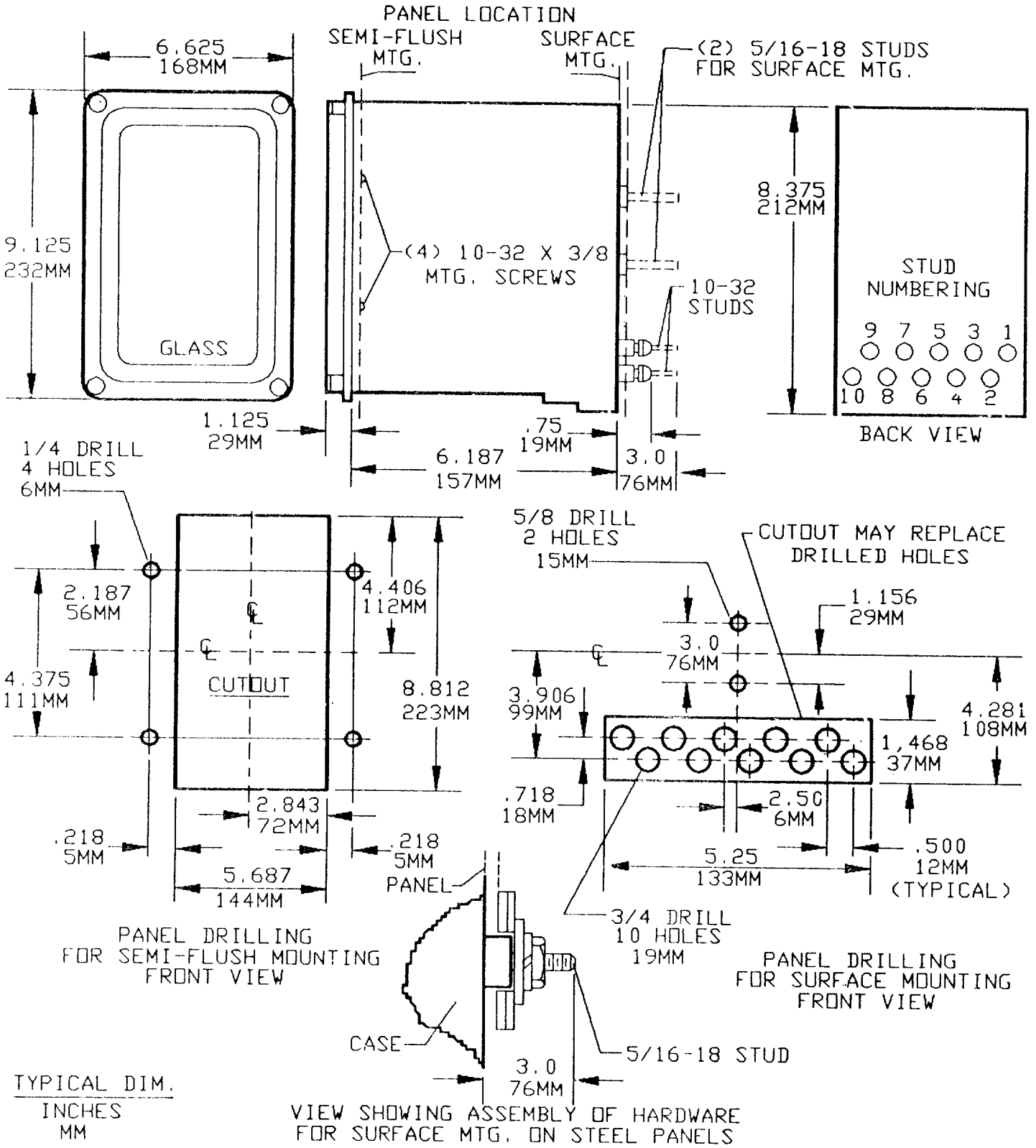
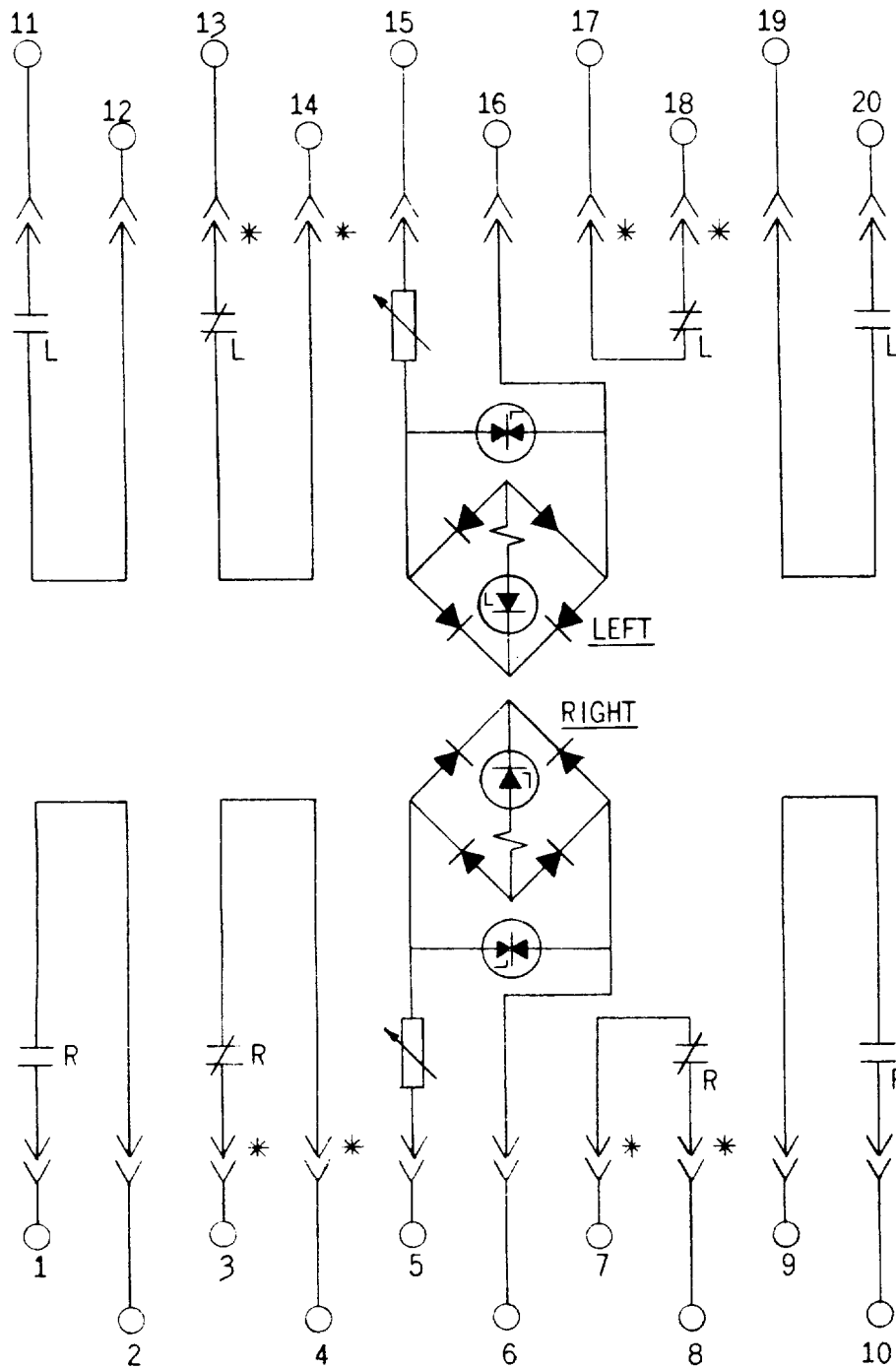

Figure 11 (K-6209271-8) Outline and Panel Drilling Dimensions for Drawout Relays - Size S1 Case



*= SHORT FINGER

Figure 12 (0178A7107-1) Internal Connections Diagram for the NGV12C(-)A Relay

Since the last edition, the first paragraph of SERVICING and Figure 10 have been revised.



GE Power Management

**215 Anderson Avenue
Markham, Ontario
Canada L6E 1B3
Tel: (905) 294-6222
Fax: (905) 201-2098
www.ge.com/indsys/pm**