



INSTRUCTIONS

INSTANTANEOUS OVERCURRENT RELAYS
TYPES PJC32C, D, E, F, G, H, J, K, L, N

GE Protection and Control
205 Great Valley Parkway
Malvern, PA 19355-1337

CONTENTS

	<u>PAGE</u>
DESCRIPTION.....	3
APPLICATION.....	4
RATINGS.....	4
Operating Coils.....	4
Contacts.....	4
CHARACTERISTICS.....	5
Operating Principles.....	5
Pickup and Reset.....	5
Operating Times.....	5
Burdens.....	6
CONSTRUCTION.....	6
RECEIVING, HANDLING AND STORAGE.....	7
ACCEPTANCE TESTS.....	7
Visual Inspection.....	7
Mechanical Inspection.....	8
Electrical Tests.....	8
INSTALLATION PROCEDURE.....	9
PERIODIC CHECKS AND ROUTINE MAINTENANCE.....	10
Mechanical Checks.....	10
Electrical Checks.....	10
SERVICING.....	10
RENEWAL PARTS.....	11

INSTANTANEOUS OVERCURRENT RELAYS

TYPES PJC32C, D, E, F, G, H, J, K, L, N

DESCRIPTION

The PJC32 relay consists of three PJC units mounted in a single unit drawout case. The various models are distinguished by different combinations of normally-open and normally-closed contacts, target and seal-in units, and contact circuit wiring, as shown in Table I.

TABLE I

RELAY TYPE	CONTACTS PER UNIT	TARGET TARGET	SEAL-IN SEAL-IN	UNIT SEAL-IN	CASE SIZE+	INTERNAL CONNEC-TIONS	CONTACT CIRCUITS
PJC32C	Two N.O.	Yes	Yes	Yes	S2	Fig. 5	SI contacts across each N.O. contact.
PJC32D	One N.O. One N.C	Yes	Yes	Yes	S2	Fig. 6	Separate N.O. & N.C. on each unit with SI contacts across each N.O.
PJC32E	One N.O. One N.C.	Yes	No	No	S2	Fig. 7	Separate N.O. & N.C. on each unit. Targets in series with N.O. contacts. (No shorting bars on N.C. contacts).
PJC32F	Two N.O.	Yes	Yes	Yes	S2	Fig. 8	Separate contacts with SI contact across one N.O. on each unit.
PJC32G	Two N.O.	No	No	No	S1	Fig. 9	All 3 left-hand contacts in parallel. All 3 right-hand contacts in parallel.
PJC32H	Two N.O.	Yes	Yes	Yes	S1	Fig. 10	Contact circuit of all 3 units connected in parallel. Separate TSI for each contact circuit.
PJC32J	Two N.O.	Yes	No	No	S2	Fig. 11	Separate contacts on each unit. Target in series with one contact on each unit.
PJC32K	One N.O. One N.C.	Yes	Yes	Yes	S1	Fig. 12	N.C. contacts not wired to terminals. N.O contacts of all 3 units wired in parallel. Separate TSI for each unit.
PJC32L	Two N.O.	Yes	No	No	S1	Fig. 13	3 left-hand contacts in parallel, 3 right-hand contacts in parallel. Separate targets for left- and right-hand circuits.
PJC32N	One N.C.	No	No	No	S1	Fig.16	3 left-hand contacts in series, 3 right-hand contacts in series

+See Figures 14 and 15

APPLICATION

The PJC32 is commonly used for instantaneous overcurrent protection of feeder circuits, and for motors in conjunction with time-delay relays. They are also used for fault detectors in conjunction with distance relays, pilot relays and the like. They are also suitable for all applications that do not require continuous operation in the picked-up condition. They can be used with definite-time DC relays to obtain time-overcurrent protection.

RATINGS

OPERATING COILS

These relays are available with various combinations of operating-coil current ratings as shown in Table II for frequencies of 25 to 60 cycles, or DC.

TABLE II
OVERCURRENT RATINGS

CONTINUOUS AMPS	ONE SECOND AMPS	PICKUP CALIBRATIONS				
1.5	75	0.5	0.8	1.25	2	
3	150	1	1.6	2.5	4	
6	275	2	3.2	5	8	
12	275	4	6.4	10	16	
25	275	10	16	25	40	
25	275	20	32	50	80	
25	275	40	64	100	160	

CONTACTS

The PJC contacts will make and carry 5 amperes continuously, or 30 amperes for 2 seconds. In cases where the PJC contacts operate a target seal-in unit, the contact-circuit rating is determined by the tap setting of the seal-in coil, as shown in Table III.

TABLE III

0.2/2.0 AMP TARGET SEAL-IN UNIT			
		Tap used	
		0.2	2.0
Carry 30 amps for	(sec.)	0.05	2.2
Carry 10 amps for	(sec.)	0.45	20
Carry continuously	(amps)	0.37	2.3
Minimum operating	(amps)	0.2	2.0
Minimum dropout	(amps)	0.05	0.5
DC resistance	(ohms)	8.3	0.24
60 hertz impedance	(ohms)	50	0.65
50 hertz impedance	(ohms)	42	0.54

Table IV shows the inductive and non-inductive interrupting ratings for a single PJC unit contact.

TABLE IV
PJC UNIT CONTACT INTERRUPTING RATINGS

AC VOLTS	AMPS	
	INDUCTIVE	NON-INDUCTIVE
115	2	5
230	1	2
460	0.5	1
DC VOLTS		
24	1.0	5
48	0.5	2
125	0.3	1
250	0.15	0.3

CHARACTERISTICS

OPERATING PRINCIPLES

These plunger-type relays operate on the principle of electromagnetic attraction. The contacts are opened or closed by an armature that is drawn up vertically into a solenoid.

PICKUP AND RESET

The overcurrent-unit pickup is continuously adjustable over a current range of approximately 4:1 as shown in Table II for the various coil ratings. Pickup is set by adjusting the vertical position of the armature on its threaded shaft. The four factory pickup calibrations shown for each rating appear on the top of the relay nameplate, and correspond to the marks on the calibrating tubes of each unit.

Reset is defined as the de-energized plunger position. The contacts will reset at approximately 85% to 95% of pickup on AC, and 70% to 95% of pickup on DC, at any point within the calibration range. Reset is not adjustable independently of pickup.

OPERATING TIMES

Time-current curves for the units are shown in Figure 2. The operating current is plotted in multiples of pickup, and the operating times are plotted in cycles on a 60-cycle time basis. The upper curve shows the closing time of a normally-open contact and the lower curve shows the opening time of a normally-closed contact.

BURDENS

The DC resistance and 60-cycle burdens imposed on a current transformer by each overcurrent unit are tabulated in Table V and Figure 3.

TABLE V
TYPE PJC32 BURDEN DATA

Continuous Amps	Pickup Range	Coil DC Ohms	60-Cycle Burden ⁺		
			Resistance	Reactance	Impedance
1.5	0.5- 2	1.40	3.8	6.3	7.6
3	1 - 4	0.35	0.83	1.7	1.9
6	2 - 8	0.091	0.22	0.43	0.49
12	4 - 16	0.023	0.055	0.11	0.13
25	10 - 40	0.005	0.011	0.018	0.021
25	20 - 80	0.0019	0.0032	0.0045	0.0055
25	40 - 160	0.0009	0.0016	0.0013	0.0020

⁺Minimum pickup calibration with pickup current applied and armature picked up.

CONSTRUCTION

Each of the three overcurrent units is of the same plunger-type construction. (Refer to Figure 1.) The adjustable armature is mounted on the threaded portion of a plunger rod that carries the moving contacts upward as the armature is operated. The armature is drawn upward into the coil by the flux created in the rectangular magnet frame and a cylindrical pole piece inside the coil. Guides for the plunger rod are provided at the top by a hole in the pole piece, and at the bottom by the fit of the molded contact carrier inside the calibration tube. Openings in the sides of the calibration tube allow access to the armature to adjust pickup. The magnet frames, stationary contacts, and plunger-stop posts for each unit are separately mounted on the common compound mounting plate. Normally-closed stationary contacts are mounted below the moving contact and bear against a contact-resting arm when the relay is picked up. Normally-open stationary contacts are mounted above the moving contact and bear against a contact-resting arm when the relay is reset. Normally-open stationary contacts are restrained against bouncing from the moving contact at high operating levels by a contact backstop. This is not necessary on normally-closed contacts, since the resetting force cannot exceed the weight of the plunger assembly.

The target seal-in unit is a small hinged-armature-type relay consisting of a "U" shaped magnet frame, fixed pole piece, armature, and tapped coil. The armature carries a "T"-shaped moving contact that bridges the two stationary contacts and also operates a hand-reset target.

The target unit is similar to the target and seal-in unit, except the contacts are omitted.

GEK-27893

These three target and seal-in or target units, when present, are mounted on a strap, which is in turn fastened across the front of the overcurrent-unit magnet frames.

All components of each relay are mounted on a cradle assembly that can easily be removed from the relay case. The cradle is locked in the case by means of latches at the top and bottom. The electrical connections between the case blocks and cradle blocks are completed through removable connection plugs. Separate testing plugs can be inserted in place of the connection plugs to permit testing the relay in its case. The cover attaches to the case from the front and includes the target-reset mechanism and an interlock arm to prevent the cover from being put back in place until the connection plug has been inserted.

The PJC32C, D, E, F, and J are mounted in a size S2 case, and the outline and panel-drilling dimensions are shown in Figure 14. Models PJC32G, H, K, L, and N are mounted in a size S1 case, the dimensions of which are given in Figure 15. Both the cases are suitable for either semiflush or surface mounting on panels up to two inches thick. Hardware is available for all panel thicknesses up to two inches, but panel thickness must be specified on the order to ensure that the proper hardware will be provided.

RECEIVING, HANDLING AND STORAGE

These relays, when not included as part of a control panel, will be shipped in cartons designed to protect them against damage. Immediately upon receipt of a relay, examine it for any damage sustained in transit. If injury or damage resulting from rough handling is evident, file a damage claim at once with the transportation company and promptly notify the nearest General Electric Sales Office.

Reasonable care should be exercised in unpacking the relay in order that none of the parts are injured nor the adjustments disturbed. If the relays are not to be installed immediately, they should be stored in their original cartons in a place that is free from moisture, dust and metallic chips. Foreign matter collected on the outside of the case may find its way inside when the cover is removed, and cause trouble in the operation of the relay.

ACCEPTANCE TESTS

Immediately upon receipt of the relay, an inspection and acceptance test should be made to make sure that no damage has been sustained in shipment and that the relay calibrations have not been disturbed.

VISUAL INSPECTION

Check the nameplate stamping to make sure that the model number, rating and calibration range of the relay, as received, agree with the requisition.

Remove the relay from its case and check by visual inspection that there are no broken or cracked molded parts or other signs of physical damage, and that all screws are tight. Also check to see that the flexible moving-contact leads extend straight back from the contacts and have not been deformed.

MECHANICAL INSPECTION

It is recommended that the following mechanical adjustments be checked:

1. Operate the plunger on each unit by hand, and allow it to reset, to make sure that all units are free from friction or binds. If two normally-open contacts are present, observe that with one contact just making, there is less than 1/64 inch gap on the other contact.
2. The wipe on a normally-open or normally-closed contact should be approximately 3/64 inch. The normally-open contact gap with the armature fully reset should be approximately 3/32 inch for either contact arrangement. Backstops should be present above all normally-open contacts only. The gap between the backstop and stationary contact at the tip should be approximately 1/16 with the armature reset. See inset, Figure 2.
3. Check the location of the contact brushes on the cradle and case blocks against the internal connection diagram for the relay. Be sure that the shorting bars are in the proper locations on the case block and that the long and short brushes on the cradle block agree with the internal connection diagram. Figure 4 shows a sectional view of the case (terminal) and cradle (connection) blocks with connection plug in place. Note that there is an auxiliary brush in each position on the case block. This brush should be formed high enough so that when the connection plug is inserted it engages the auxiliary brush before striking the main brush. This is especially important in current circuits, and other circuits with shorting bars, since an improper adjustment of the auxiliary brush could result in a CT secondary circuit being momentarily open-circuited.
4. The target or target and seal-in units, when present, should be checked as follows. The armature and seal-in contacts should move freely when operated by hand. There should be a screw in **only one** of the tap positions on the right stationary contact strip. Operate the armature by hand and be sure the target latches in its exposed position before the contacts close. There should be at least 1/32" wipe on the seal-in contacts. With the cover fastened securely in place, check that the target resets positively when the reset button at the bottom of the cover is operated.

ELECTRICAL TESTS

It is recommended that the following electrical checks be made immediately upon receipt of the relay. Note that all tests should be made with the relay in its case and in a level position.

1. Pickup and Reset - The units are normally supplied from the factory with the bottom of the armature aligned with the top mark on the calibration tube. This corresponds to the minimum pickup setting on the nameplate. It should be sufficient to check the pickup of each unit at this setting.

With gradually increasing test current in the operating coil the unit should pick up, closing its normally-open contacts with one continuous motion, at the calibrated current level. The test current should then be gradually decreased until the contacts reset. The reset value should be between 85% and 95% of pickup on AC, or between 70% and 95% on DC.

2. Target and Seal-in Unit - The following tests should be made on those relays having target or target-and-seal-in units. Refer to the appropriate internal-connections diagram, and arrange a test circuit to apply gradually increasing DC current through the target/seal-in circuit. With the target in the "down" or unexposed position and the associated main contact held closed by hand, check pickup on both the 0.2 and 2.0 ampere tap. (Refer to the section on target seal-in unit settings under **INSTALLATION PROCEDURE** for the recommended steps to change the tap setting.) Pickup current should be tap rating or less.

On units having seal-in contacts, also open the main-unit contacts by hand with pickup current still flowing, and check that the target seal-in unit remains picked up.

INSTALLATION PROCEDURE

If after the performance of the **ACCEPTANCE TESTS** the relay is held in storage before shipment to the job site, it is recommended that the visual and mechanical inspection described in the section on **ACCEPTANCE TESTS** be repeated before installation.

The following electrical adjustments should be made with the relay in its case, preferably mounted in its permanent location.

1. Pickup - The desired pickup on each overcurrent unit may be set as follows, using test current of the expected service frequency. Turn the bottom of the knurled armature to the approximate position in the calibration tube corresponding to the desired pickup setting. Gradually apply increasing test current to the operating coil by use of a relay testing plug; if the pickup is too high, turn the armature to lower it slightly in the calibration tube. Recheck pickup and readjust the armature if necessary until the desired pickup calibration is obtained. Make a record of the pickup reading for future reference. Check to see that the unit resets between 85% and 95% of pickup on AC, or between 70% and 95% of pickup on DC.
2. Target Seal-in Unit - As shipped from the factory, the tap screw of the target seal-in unit will be in the 2.0 ampere tap. To change the tap setting, remove a tap screw from the left stationary contact member and insert it in the vacant tap on the right stationary contact member. Then remove the original screw from the undesired tap on the right contact member and place it in the spare position on the left contact member. This procedure is recommended to avoid disturbing the adjustment of the right stationary contact. Screws should **never** be left in **both** tap positions on the right stationary contact member.

PERIODIC CHECKS AND ROUTINE MAINTENANCE

In view of the vital role of protective relays in the operation of a power system, it is important that a periodic test program be followed. Unless otherwise dictated by unusual environmental conditions, it is recommended that the following points be checked at an interval of from one to two years.

MECHANICAL CHECKS

Manually operate each overcurrent-unit armature and allow it to reset, to make sure that there is no excessive friction or tendency to bind.

Check to see that the contacts have approximately 3/64 inch wipe and that the normally-open contact gap is approximately 3/32 inch with the armature reset. Check to see that the backstops on the normally-open contact are approximately 1/16 inch above the stationary contact tips.

Examine the contact surfaces for signs of tarnishing or corrosion. The fine silver contacts should be cleaned with a burnishing tool, which consists of a flexible strip of metal with an etched, roughened surface. Burnishing tools designed especially for cleaning relay contacts can be obtained from the factory. Do not use knives, files or abrasive paper or cloth of any kind to clean relay contacts.

Operate each target seal-in unit by hand and check that the target latches before the contacts make, and that the contacts have at least 1/32 inch wipe. Check target units when present, to make sure that the target latches before the armature closes against the pole piece. With the cover restored to its place, check that all targets reset when the reset button is operated.

ELECTRICAL CHECKS

Refer to the appropriate internal-wiring diagram and, with the use of a relay test plug, check the pickup on each overcurrent unit. This pickup should be within 3% of the corresponding reading recorded during installation. The reset current should also be checked to be sure that it is within 85% to 95% of pickup on AC or 70% to 95% on DC.

It is not recommended that the relay be readjusted when minor pickup variations from the previous test are noted, as long as the relay is still within limits. Such deviation can be introduced by differences in test equipment or by human error.

SERVICING

If any of the mechanical or electrical check points described in the previous sections are found to be out of limits, the following points should be observed in restoring them.

1. Friction - If there is any tendency to bind or excessive friction is

present, check to see that the molded contact carrier has adequate clearance from the "T"-shaped armature-guide bracket. There should be no tendency for the armature to rotate and bind against the guide bracket as the relay operates. Also check that no foreign matter is present between the armature and calibrating tube.

2. Moving Contact Leads - The flexible moving-contact leads should be formed to keep the moving-contact assembly centrally located. If these moving-contact leads have been deformed, they should be reshaped as follows: The insulated portion of the lead should extend straight back to the slot in the compound mounting plate. There should be a 90° bend in the lead at a point just beyond the end of the insulating sleeve, and the bare lead should project either up or down to the terminal screw.
3. Stationary Contact Tension - Initial tension is the force applied to the contact tip to cause the moving contact to move to a position where the contact brush (stationary contact) just starts to move away from its backstop. This initial tension should be approximately 5 grams on each contact, unless the relay has one normally-open and one normally-closed contact ((Code 11). For Code 11, the initial tension on each contact brush should be approximately 15 grams. Whenever the contacts are readjusted, the wipe and gap should also be rechecked, as outlined in the **ACCEPTANCE TESTS** and **PERIODIC CHECKS AND ROUTINE MAINTENANCE** sections, as well as the pickup adjustment, as outlined in the **INSTALLATION PROCEDURE** section.
4. Target and Seal-in Unit - If the wipe on the target and seal-in unit contact is found to be less than the 1/32 inch specified, it can be increased by lowering the position of the stationary contact members. When correctly adjusted, both contacts should make at approximately the same time when the armature is operated by hand, and the target should latch in the exposed position slightly before the contacts close.

RENEWAL PARTS

Sufficient quantities of renewal parts should be kept in stock for the prompt replacement of any that are worn, broken or damaged.

When ordering renewal parts, address the nearest Sales Office of the General Electric Company. Specify the name of the part wanted, quantity required, and complete nameplate data, including the serial number, of the relay. If possible, give the General Electric Company requisition number on which the relay was furnished.

LIST OF FIGURES

<u>FIGURE</u>	<u>DESCRIPTION</u>
1A	Relay Type PJC32C Removed from Case, 3/4 Front View
1B	Relay Type PJC32C Removed from Case, Rear View
2	Time-Current Curves for the PJC32 Relays
3	Saturation Curves for type PJC32 Relays
4	Cross Section of Drawout Case Showing Position of Auxiliary Brush
5	Internal Connections Diagram for the PJC32C Relay (Front View)
6	Internal Connections Diagram for the PJC32D Relay (Front View)
7	Internal Connections Diagram for the PJC32E Relay (Front View)
8	Internal Connections Diagram for the PJC32F Relay (Front View)
9	Internal Connections Diagram for the PJC32G Relay (Front View)
10	Internal Connections Diagram for the PJC32H Relay (Front View)
11	Internal Connections Diagram for the PJC32J Relay (Front Panel)
12	Internal Connections Diagram for the PJC32K Relay (Front View)
13	Internal Connections Diagram for the PJC32L Relay (Front View)
14	Outline and Mounting Dimensions for the S2 Case
15	Outline and Mounting Dimensions for the S1 Case
16	Internal Connections Diagram for the PJC32N Relay (Front View)

Since the last edition, Figure 14 has been changed.

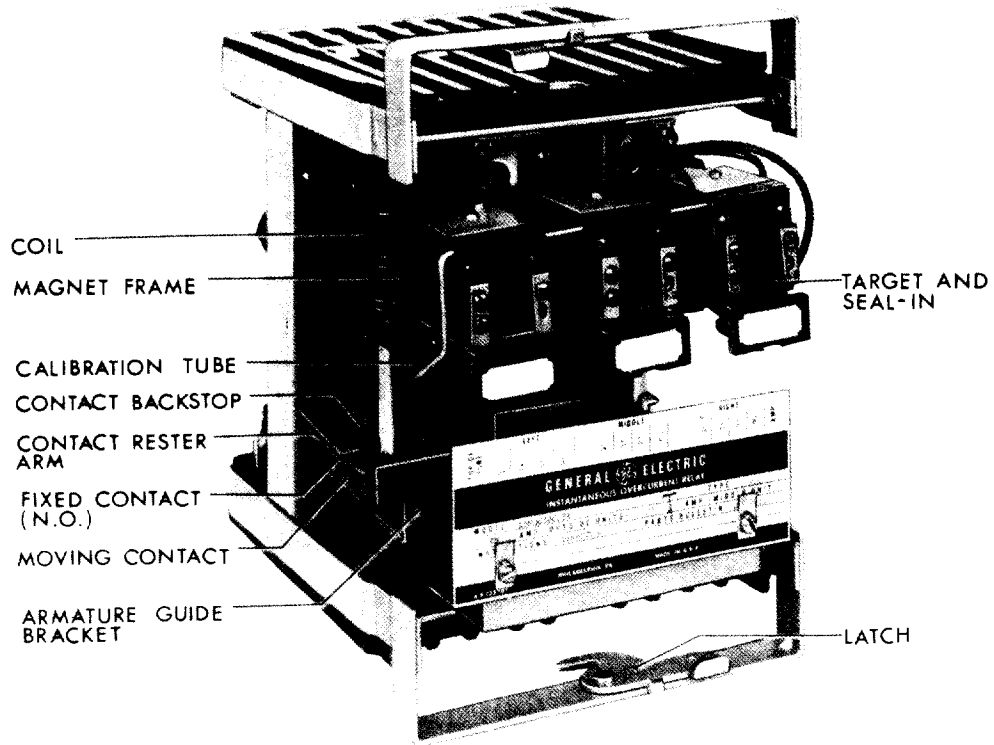

Figure 1A (8042579) Relay Type PJC32C Removed from Case, 3/4 Front View

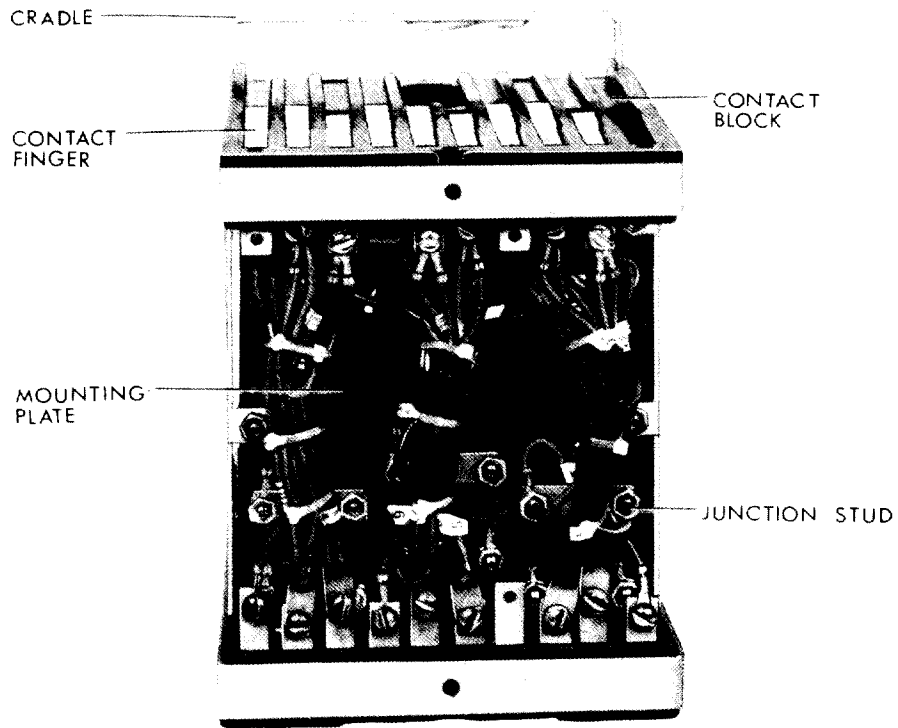
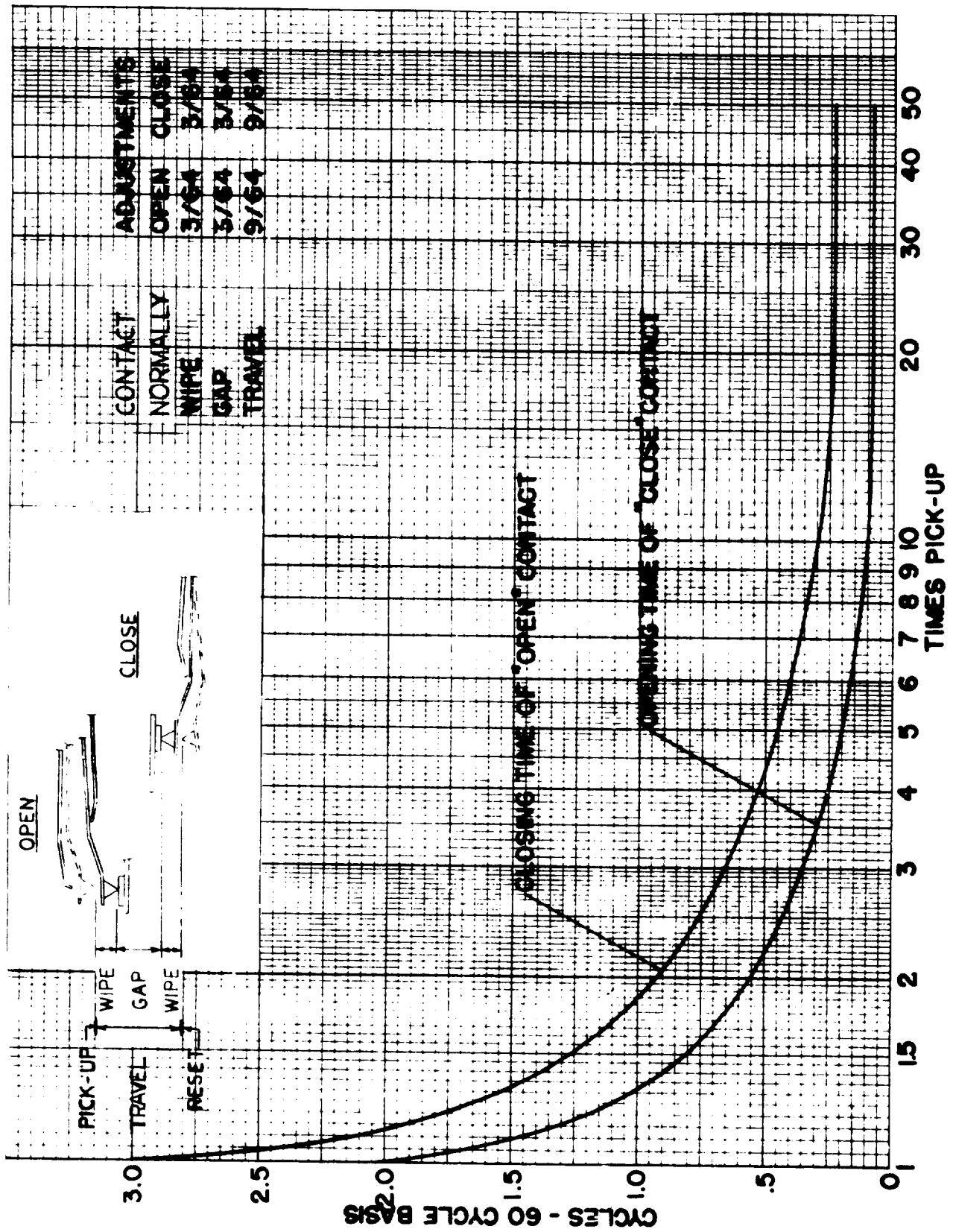

Figure 1B (8042580) Relay Type PJC32C Removed from Case, Rear View



* Figure 2 (0418A0711-1) Time-Current Curves for the PJC32 Relays

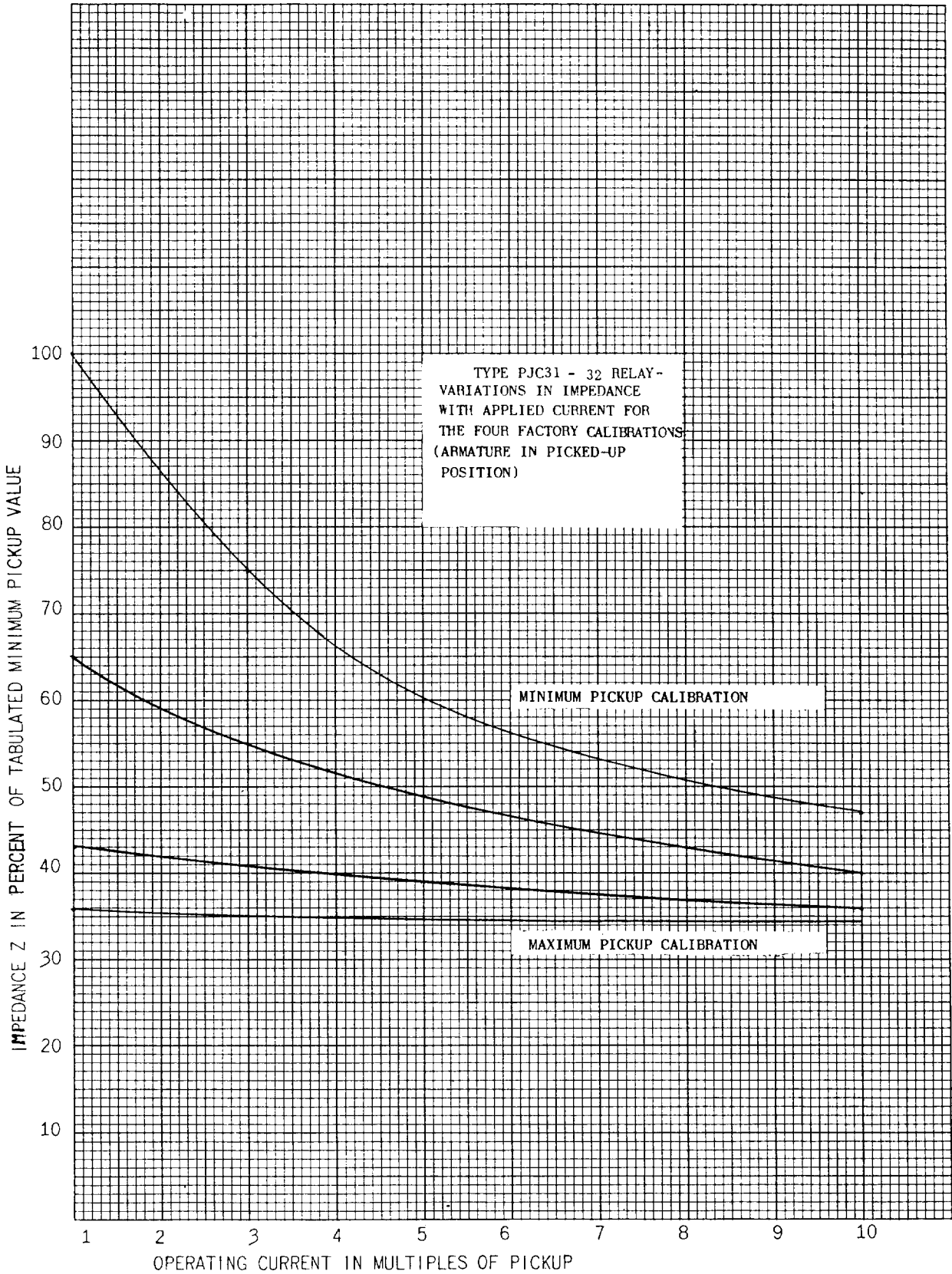
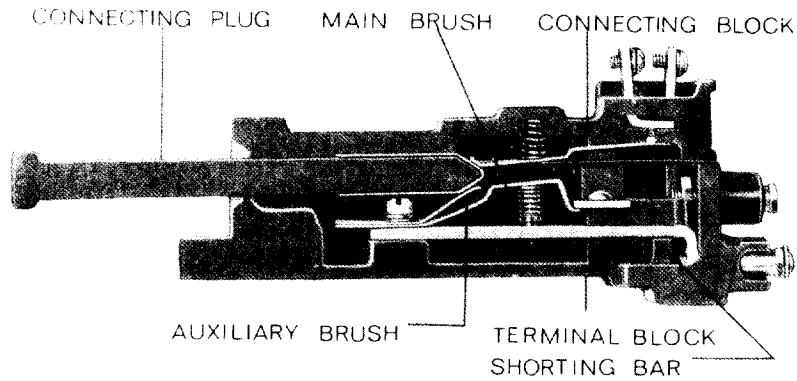

Figure 3 (0148A3992-1) Saturation Curves for Type PJC32 Relays



NOTE: AFTER ENGAGING AUXILIARY BRUSH CONNECTING PLUG TRAVELS 1/4 INCH BEFORE ENGAGING THE MAIN BRUSH ON THE TERMINAL BLOCK

Figure 4 (8025039) Cross Section of Drawout Case Showing Position of Auxiliary Brush

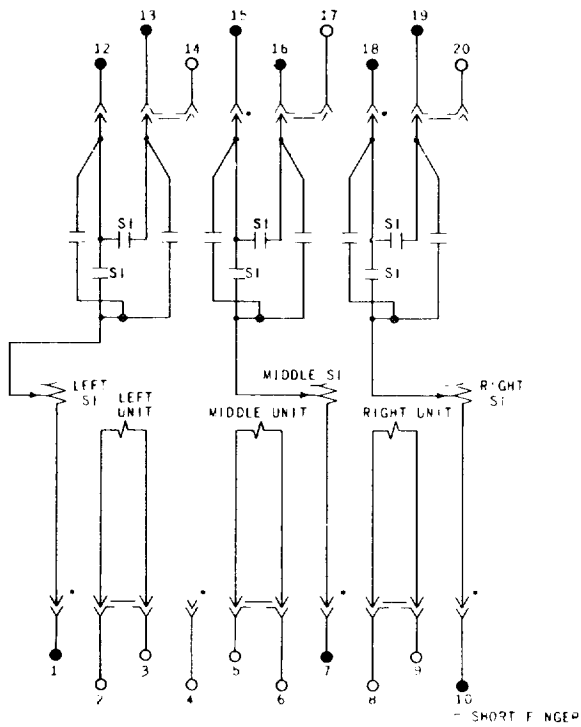

Figure 5 (6375726-5) Internal Connections Diagram for the PJC32C Relay (Front View)

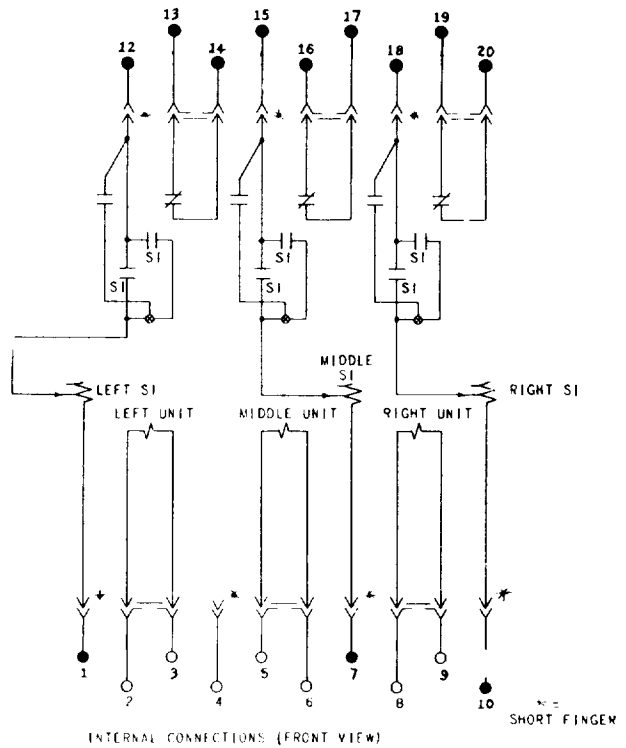

Figure 6 (6375727-4) Internal Connections Diagram for the PJC32D Relay (Front View)

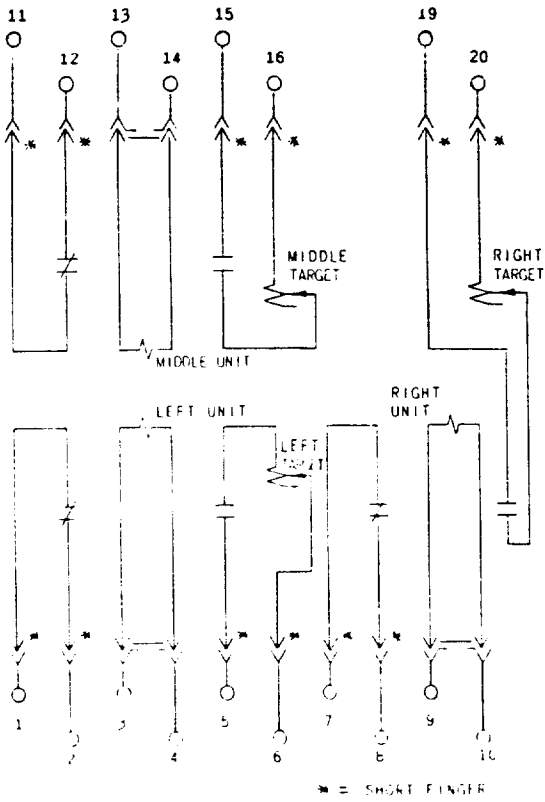

Figure 7 (0402A0946-2)
Internal Connections Diagram
for the PJC32E Relay (Front View)

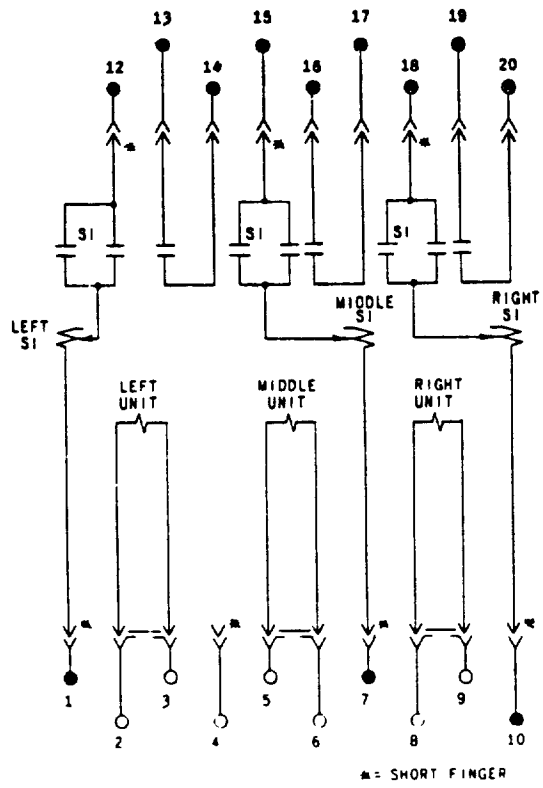

Figure 8 (0402A0940-2)
Internal Connections Diagram
for the PJC32F Relay (Front View)

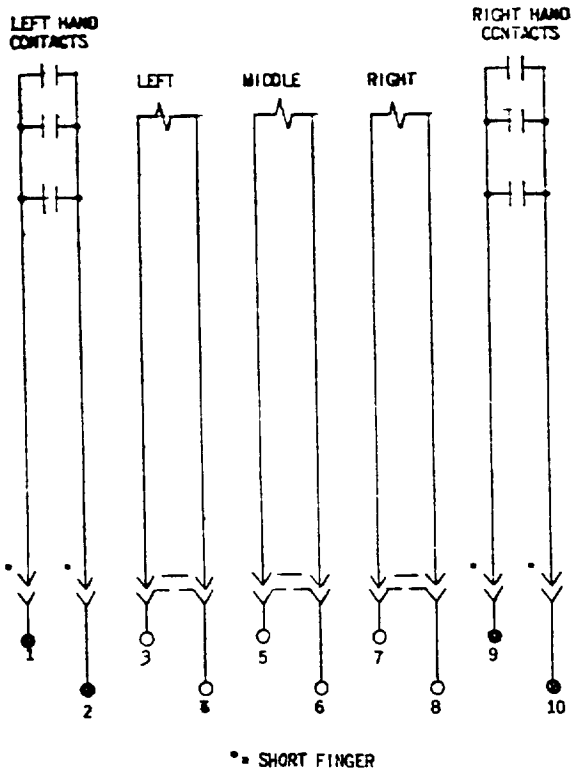

Figure 9 (K-6154875-5)
Internal Connections Diagram
for the PJC32G Relay (Front View)

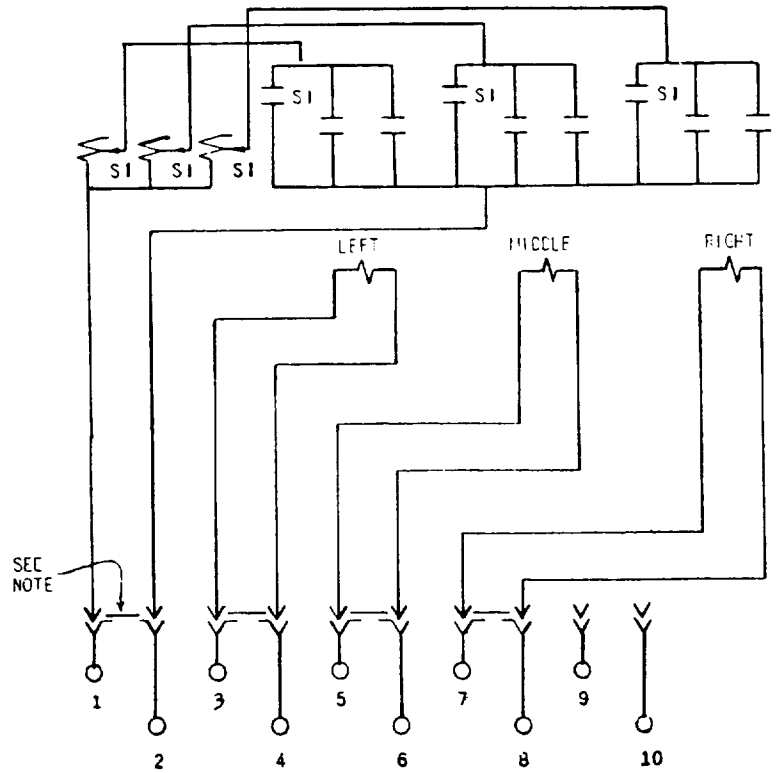

Figure 10 (0226A7242-1)
Internal Connections Diagram
for the PJC32H Relay (Front View)

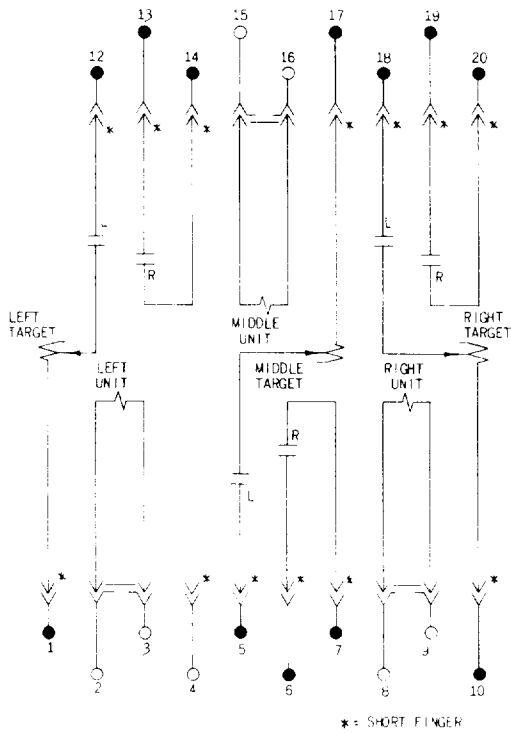

Figure 11 (0104A8955-1)
Internal Connections Diagram
for the PJC32J Relay (Front View)

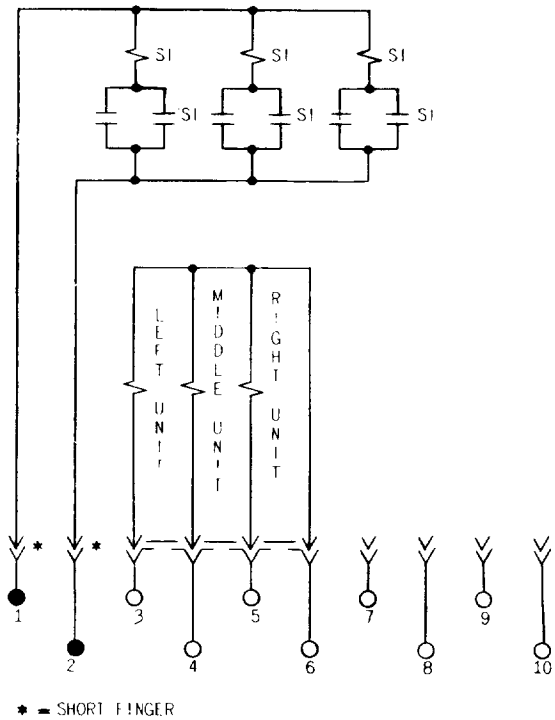

Figure 12 (0127A9575-1)
Internal Connections Diagram
for the PJC32K Relay (Front View)

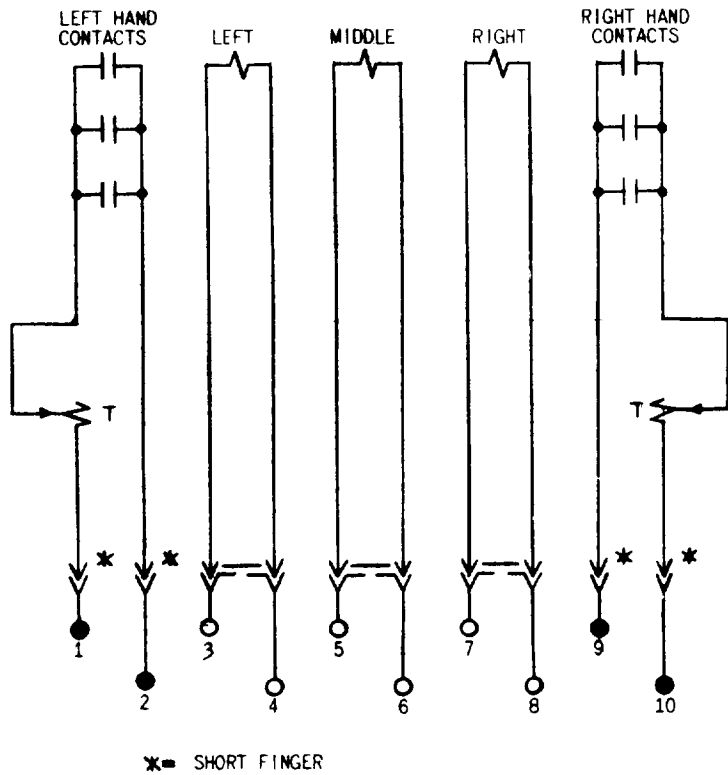

Figure 13 (0127A9547-2)
Internal Connections Diagram
for the PJC32L Relay (Front View)

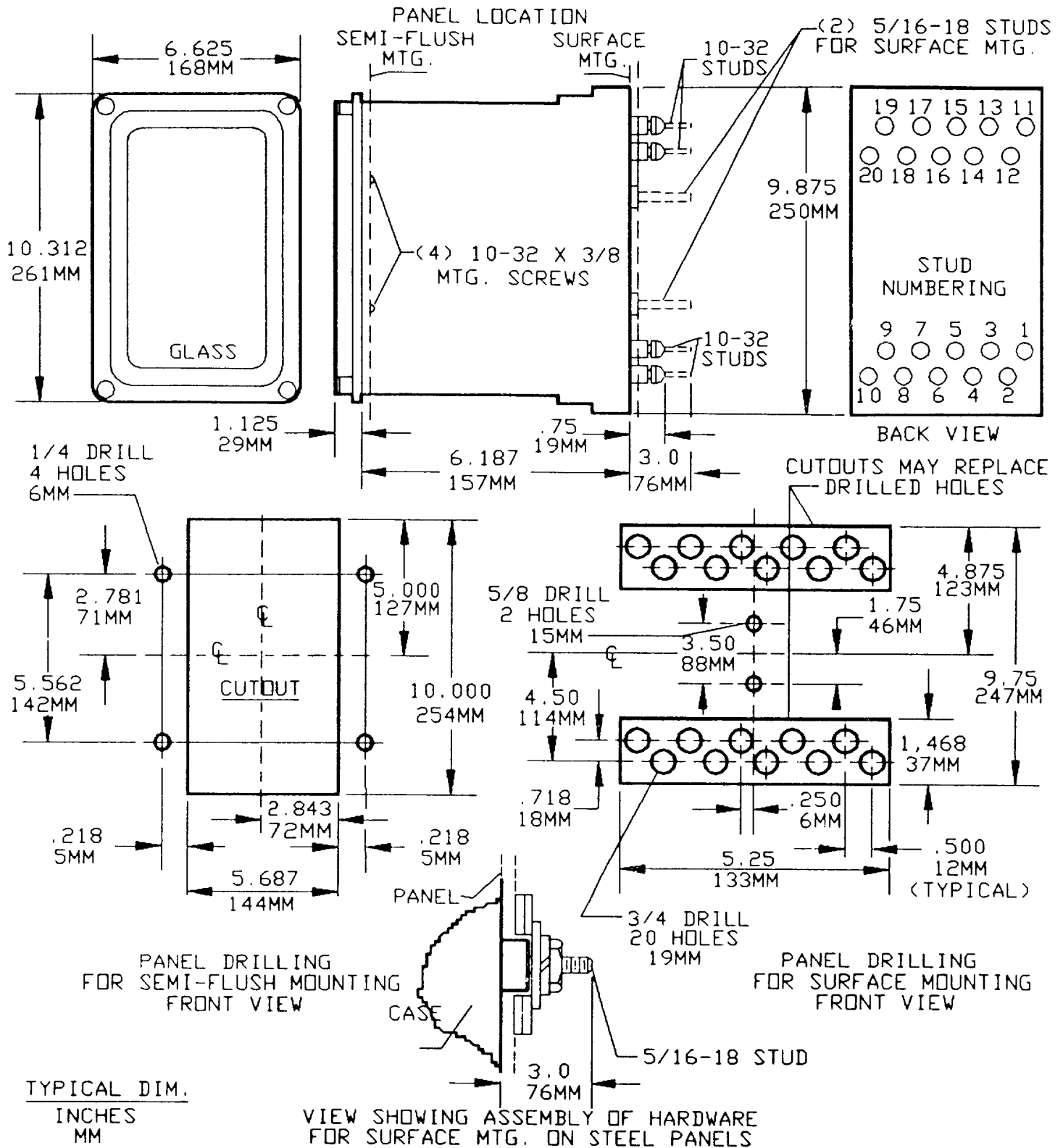

Figure 14 (K-6209272 [7]) Outline and Mounting Dimensions for the S2 Case

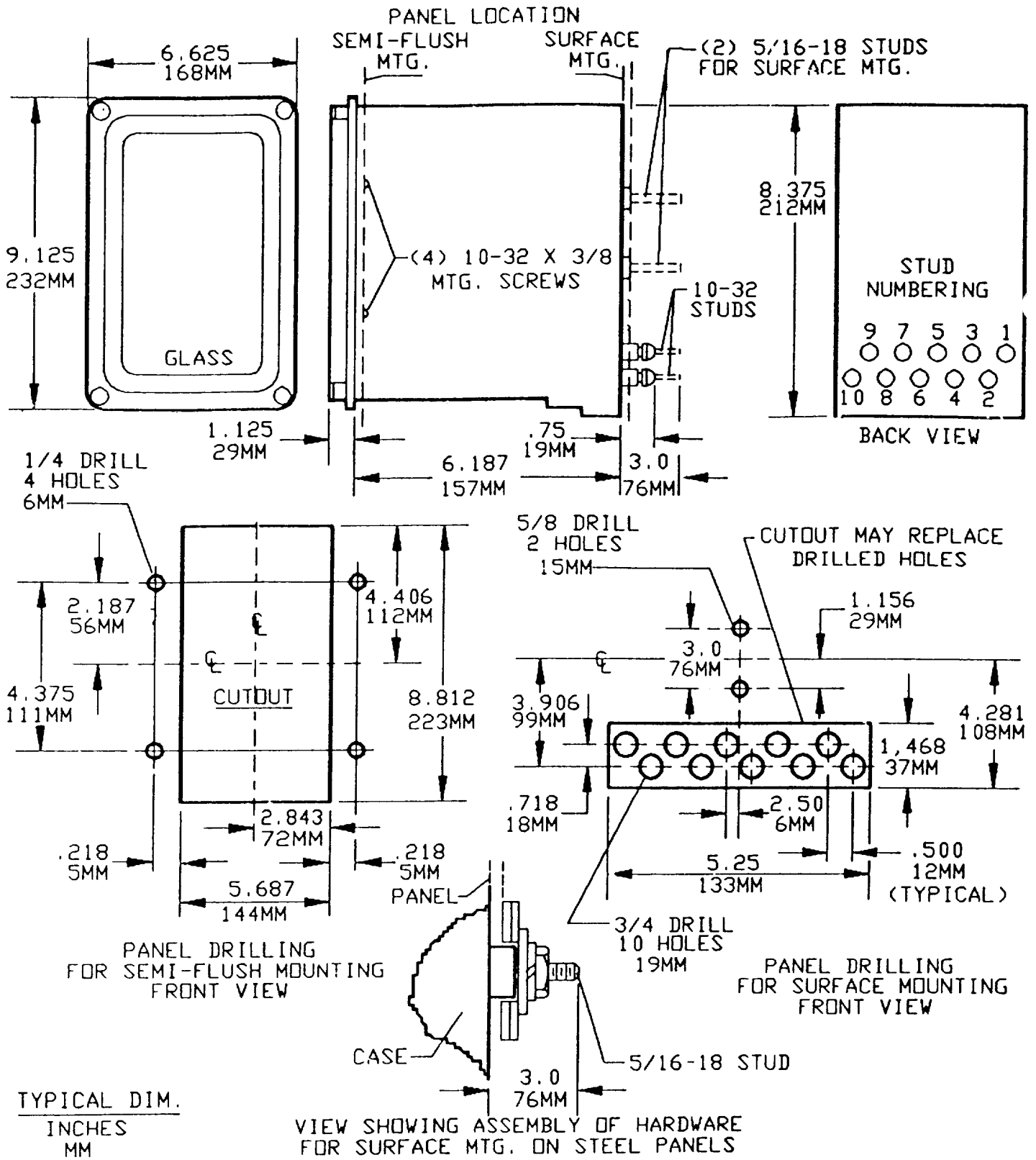

Figure 15 (K-6209271-8) Outline and Mounting Dimensions for the S1 Case

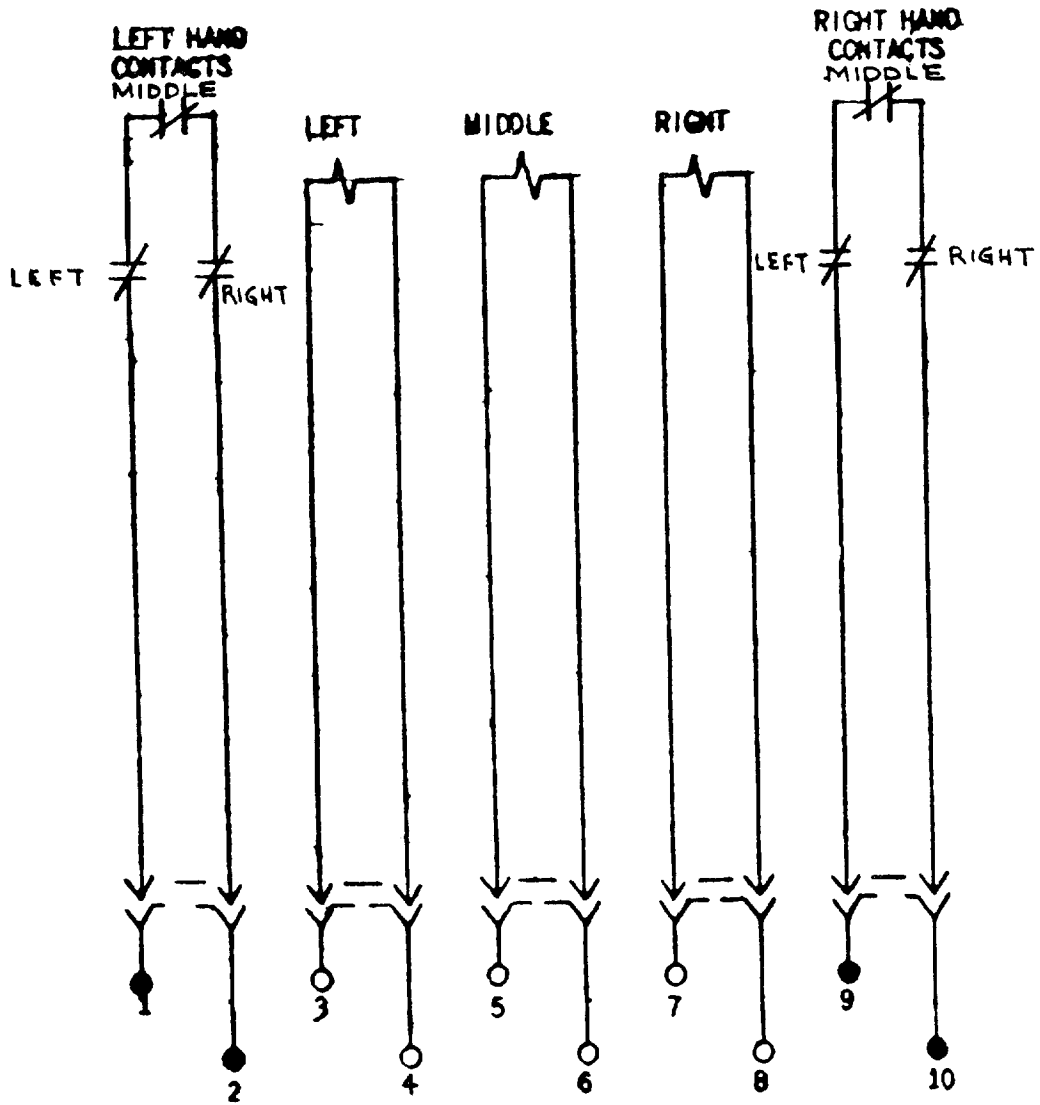

Figure 16 (0286A2870) Internal Connections Diagram for the PJC32N Relay (Front View)



GE Power Management

**215 Anderson Avenue
Markham, Ontario
Canada L6E 1B3
Tel: (905) 294-6222
Fax: (905) 201-2098
www.ge.com/indsys/pm**