



INSTRUCTIONS

GEI-28802F
Supersedes GEI-28802E

INSTANTANEOUS VOLTAGE RELAYS

TYPES

PJV11J	PJV11AL	PJV11AZ
PJV11L	PJV11AM	PJV11BF
PJV11N	PJV11AN	PJV12B
PJV11AF	PJV11AR	PJV12C
PJV11AH	PJV11AS	PJV14B
PJV11AJ	PJV11AT	PJV14C
PJV11AK	PJV11AW	PJV15A

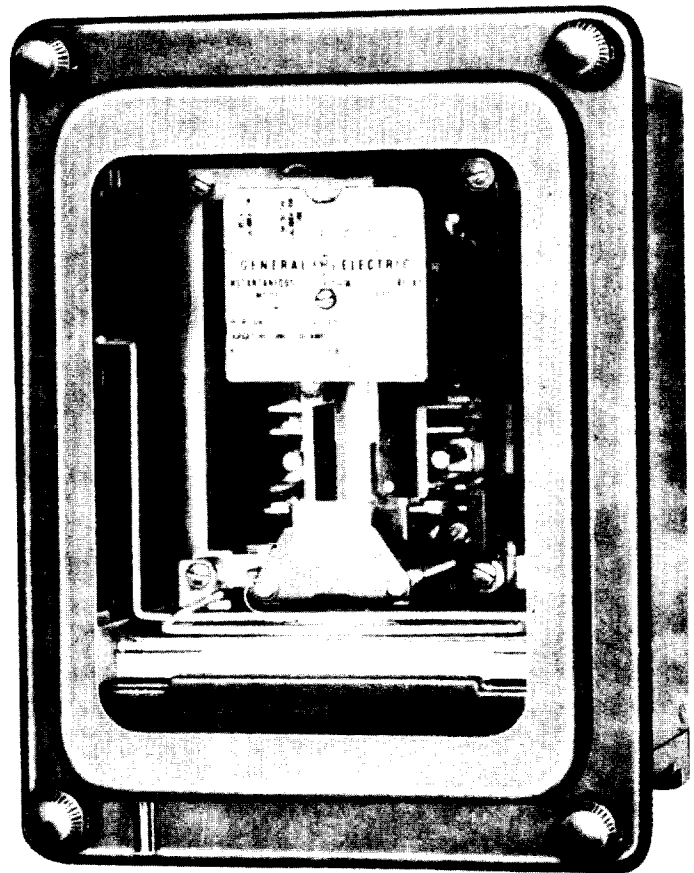

GENERAL  ELECTRIC

GEI-28802

NOTES

Cover (8073388)

INSTANTANEOUS VOLTAGE RELAY**TYPE PJV****INTRODUCTION**

The Type PJV relay is a high-speed relay designed to be used for undervoltage and overvoltage protection of AC and DC circuits and apparatus. It is nondirectional and instantaneous in operation and has high drop-out values. The AC relays are not intended for continuous operation in the picked up position. The different types and their variations are summarized in Table III and performance characteristics are shown in Fig. 1 and 2.

RECEIVING, HANDLING AND STORAGE

Immediately upon receipt of a relay, examine it for any damage sustained during shipment. If injury or rough handling is evident, a damage claim should be filed at once with the transportation company, and the nearest General Electric Sales Office should be notified.

DESCRIPTION

These relays consist of one or more units mounted in a relay case. The units are plunger type units with the armature adjustable on the plunger rod to vary the pickup. The movable contacts are fastened directly to the armature assembly on each side of the calibrating tube.

The types available as summarized in Table IV have any of a combination of the following features: one or more relay units, two or more contacts, with or without mechanical target, self or hand reset of contacts, size of case, and for undervoltage or overvoltage protection.

All targets are provided with external reset buttons, which also reset the contacts of hand-reset forms. The case is suitable for either surface or semiflush panel mounting and an assortment of hardware is provided for either mounting.

These instructions do not purport to cover all details or variations in equipment nor to provide for every possible contingency to be met in connection with installation, operation or maintenance. Should further information be desired or should particular problems arise which are not covered sufficiently for the purchaser's purposes, the matter should be referred to the General Electric Company.

To the extent required the products described herein meet applicable ANSI, IEEE and NEMA standards; but no such assurance is given with respect to local codes and ordinances because they vary greatly.

RATINGS AND BURDENS

TABLE I

RATING		CAL. RANGE	VOLT-AMPS			WATTS		
VOLTS	FREQ.		A	B	C	A	B	C
115	60	70-160	5.52	8.56	9.3	2.56	4.15	4.9
115	50	70-160	5.0	6.8	7.8	2.03	3.2	4.1
115	25	70-160	1.9	2.5	2.8	1.0	1.6	1.9
230	60	140-320	5.52	8.56	9.3	2.56	4.15	4.9
230	50	140-320	5.0	6.8	7.8	2.03	3.2	4.1
230	25	140-320	1.9	2.5	2.8	1.0	1.6	1.9
460	60	280-640	5.52	8.56	9.3	2.56	4.15	4.9
460	50	280-640	5.0	6.8	7.8	2.03	3.2	4.1
460	25	280-640	1.9	2.5	2.8	1.0	1.6	1.9
* 125	DC	50-160	--	--	--	15.6	15.6	15.6
* 250	DC	100-320	--	--	--	16.7	16.7	16.7

A = at rated volts with plunger set for pickup at minimum point of range.
 B = at rated volts with plunger set for pickup at rated volts.
 C = at rated volts with plunger set for pickup at maximum point of range.

TARGET AND SEAL-IN UNIT

The ratings of the target and seal-in unit on PJV11AZ are listed in Table II.

TABLE II

	2 Amp Tap	0.2 Amp Tap
Carry Tripping Duty	30 Amps	5 Amps
Carry Continuously	3 Amps	0.3 Amps
DC Resistance	0.13 Ohms	7 Ohms
Impedance (60 Cycles)	0.53 Ohms	52 Ohms

CONTACTS

The contacts will carry five amps continuously or 30 amps for tripping. The contact interruption capacities are given in Table III.

TABLE III

	DC				AC			
VOLTS	24	48	125	250	115	230	460	
AMPS	5	2	1	0.3	5	2	1	

CHARACTERISTICS

The time voltage curves are shown in Fig. 1 and 2. The pickup voltage is adjustable for 61 to 139 percent of the rating. The drop-out voltage is 90 to 95 percent of the pickup voltage on AC and 70 to 90 percent on DC circuits. The drop-out voltage is not adjustable.

TABLE IV

TYPE	NO. OF RELAY UNITS	CONTACTS EACH UNIT		TARGET M=MECH. O=NONE	RESET # H=HAND S=SELF	TYPE OF CASE	OUTLINE FIG. NO.	INT. CONN. FIG. NO.	RELAY TYPE AC OR DC	
		NO.	CODE						**OVER-VOLTAGE	UNDER-VOLTAGE
PJV11J	3	2	11	O	S	M2	5	6		AC
PJV11L	1	2	all	O	S	S1	3	8		AC
PJV11N	3	2	11	M	S	M2	5	6	AC	
PJV11AF	1	2	all	M	S	S1	3	8	AC	
PJV11AH	2	2	all	M	S	S2	4	9	AC	
PJV11AJ	2	2	all	O	S	S2	4	9		AC
PJV11AK	1	2	all	O	S	S1	3	8		DC
* Δ PJV11AL	2	2	all	O	S	S2	4	9		DC
+ PJV11AM	1	2	all	M	S	S1	3	8	DC	
* Δ+ PJV11AN	2	2	all	M	S	S2	4	9	DC	
Δ PJV11AR	3	2	11	M	S	M2	5	7	AC	
PJV11AS	3	2	all	M	S	M2	5	12	AC	
Δ PJV11AT	2	2	all	O	S	S2	4	9	AC	
PJV11AW	1	2	all	M	S	S1	3	8		AC
* Δ PJV11AZ	1	2	20	≠	S	S1	3	13	AC	
* Δ PJV11BF	1	2	all	M	S	S1	3	8	AC	
* Δ PJV12B	1	2	all	M	H	S1	3	8	AC	
* Δ PJV12C	3	2	11	M	H	M2	5	6	AC-DC	
* PJV14B	1	4	22	O	S	S2	4	11		AC-DC
PJV14C	1	4	22	M	S	S2	4	11	AC-DC	
PJV15A	1	4	22	M	H	S1	3	10	AC-DC	

- # Hand-reset relays - Hand-reset on normally closed contacts only.
- ** Gvervoltage relay - AC - Not for continuous operation in picked up position.
- + Dropout equals 80 percent to 95 percent of pickup voltage.
- ≠ Target Seal-in Unit.
- Δ Obsolete Relay

INSTALLATION

LOCATION AND MOUNTING

A relay purchased as part of a switchboard is shipped already mounted. A relay purchased separately is packed in a carton so that ordinary shocks will not impair its accuracy. The relay should be examined upon receipt to see that no damage has been sustained in transit.

The relay should be mounted on a vertical surface where it will not be subjected to excessive heat, vibration, or shock, and in a location that is well lighted to facilitate periodic testing.

* See drawings at the back of the book for dimensions and drilling plans; these outline drawings are listed in Table IV.

After the relay is mounted the contacts should be closed and released manually a few times to make sure that the moving parts are free and in alignment.

One of the mounting studs or screws should be permanently grounded by a conductor not less than No. 12 B&S gage copper wire or its equivalent.

CONNECTIONS

The internal connections are shown on the diagrams listed in Table IV.

All relays, with the exception of those having three units, are provided with shorting bars on the individual contacts, arranged so that the use of them is optional. The contacts can be shorted out or not, when the plug is removed, depending on the terminals used for the external connections. For example in Fig. 8, for the relay Type PJV11F, external connections are made to 1-2 and 9-10, if shorting bars are to be omitted. Connections are made to terminals 2-3 and 8-9 if shorting bars are to be applied.

OPERATION

In all types, the moving contacts are operated directly by the plunger assembly.

On types that have a mechanical target, the target is lifted by a cross pin through the plunger rod. The target, when lifted, rises from behind the target shield to a position where it is visible. It latches there and must be reset by hand.

Hand reset contact action is provided by connecting the plunger directly to the target lever, so that the target lever holds up the plunger assembly until the target is reset.

Any desired setting within the calibrating range may be obtained by turning the armature on the plunger rod. The armature is provided with an internal locking spring which requires no manipulation.

On any form of PJV relay, the number associated with any given calibrating mark on the calibrating tube is found on the nameplate. For overvoltage relays this is the value at which the relay will just pick up and close its "a" contacts if the bottom of the armature is adjusted to the calibrating mark in the de-energized position. For undervoltage relays the values are the voltages at which the relay will just drop out and open its "a" contacts.

MAINTENANCE

These relays are adjusted at the factory and it is advisable not to disturb the adjustments. If for any reasons they have been disturbed, the following points should be observed in restoring them.

PERIODIC TESTING

An operation test and an inspection of the relay at least once every six months are recommended.

CONTACT CLEANING

For cleaning fine silver contacts, a flexible burnishing tool should be used. This consists of a flexible strip of metal with an etched-roughened surface, resembling in effect a superfine file. The polishing action is so delicate that no scratches are left, yet corroded material will be removed rapidly and thoroughly. The flexibility of the tool insures the cleaning of the actual points of contact.

Fine silver contacts should not be cleaned with knives, files, or abrasive paper or cloth. Knives or files may leave scratches which increase arcing and deterioration of the contacts. Abrasive paper or cloth may leave minute particles of insulating abrasive material in the contacts, and thus prevent closing.

The burnishing tool described above can be obtained from the factory.

ADJUSTMENTS AND INSPECTION

The normal adjustment of contacts is 3/64 inch wiper. This may be adjusted by bending the contact stops that lie between the stationary contact springs, and the ribs on the molded base. The bend should be made about 1/4 inch from the front tip of the stop, so as to obtain an exact setting more easily than it should be obtained by bending next to the base. A change in wiper on a "b" contact affects the pickup for a given armature setting in the de-energized position. An increase in wiper on either the "a" or the "b" contacts decreases the contact gap and increases the difference between pickup and dropout, and vice versa.

The contact pressure in the fully picked up or dropped out position may be adjusted by bending the stationary contact springs near this point of attachment to the base. This adjustment may change the contact gap and contact wiper slightly. Adjustments of the contact stops within the normal range do not affect the contact pressure in the fully picked up or dropped out position, as the contact springs are separated from the stops in these positions.

RENEWAL PARTS

It is recommended that sufficient quantities of renewal parts be carried in stock to enable the prompt replacement of any that are worn, broken or damaged.

When ordering renewal parts, address the nearest Sales Office of the General Electric Company, specifying the quantity required and describing the parts by catalog numbers as shown in renewal parts bulletin No. 3856.

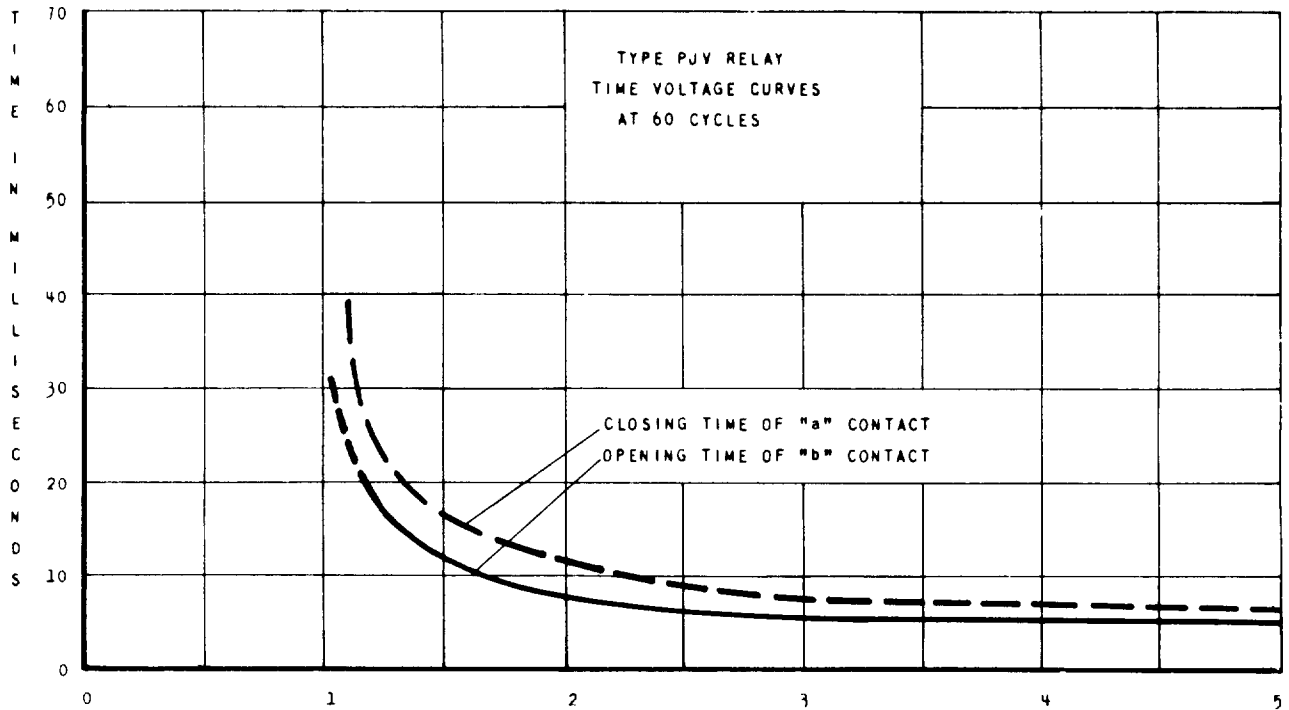

Fig. 1 (K-6375897-0) Voltage in Multiples of Pickup

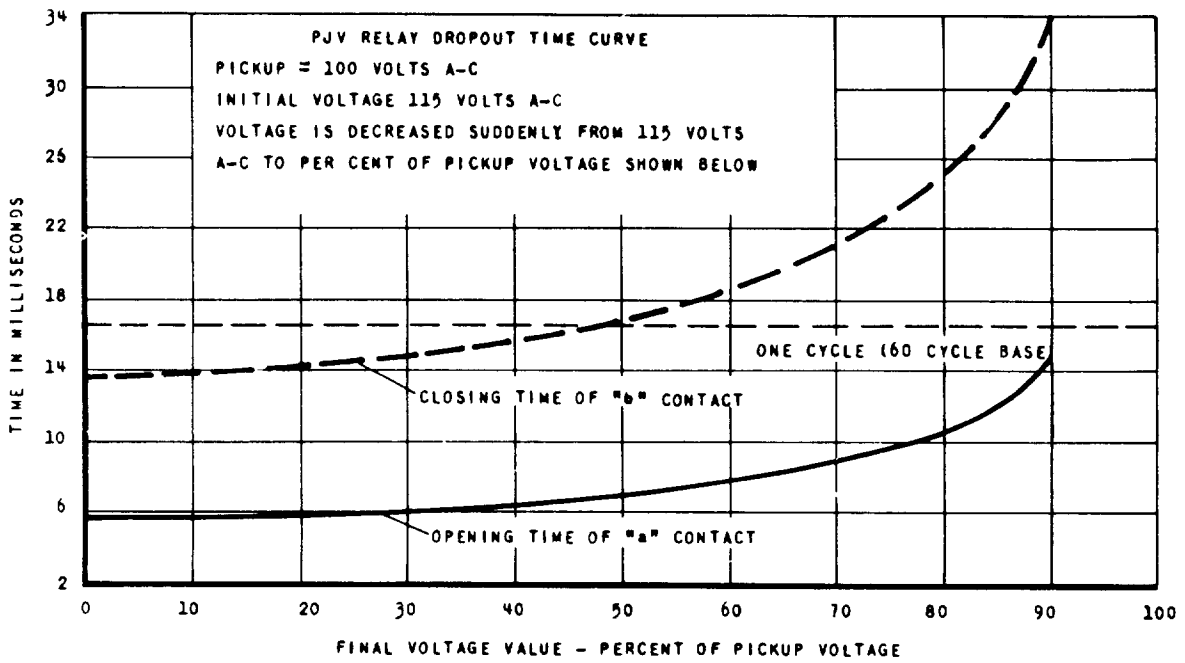

Fig. 2 (K-6375898-0) Characteristic Time Curves for PJV Relays

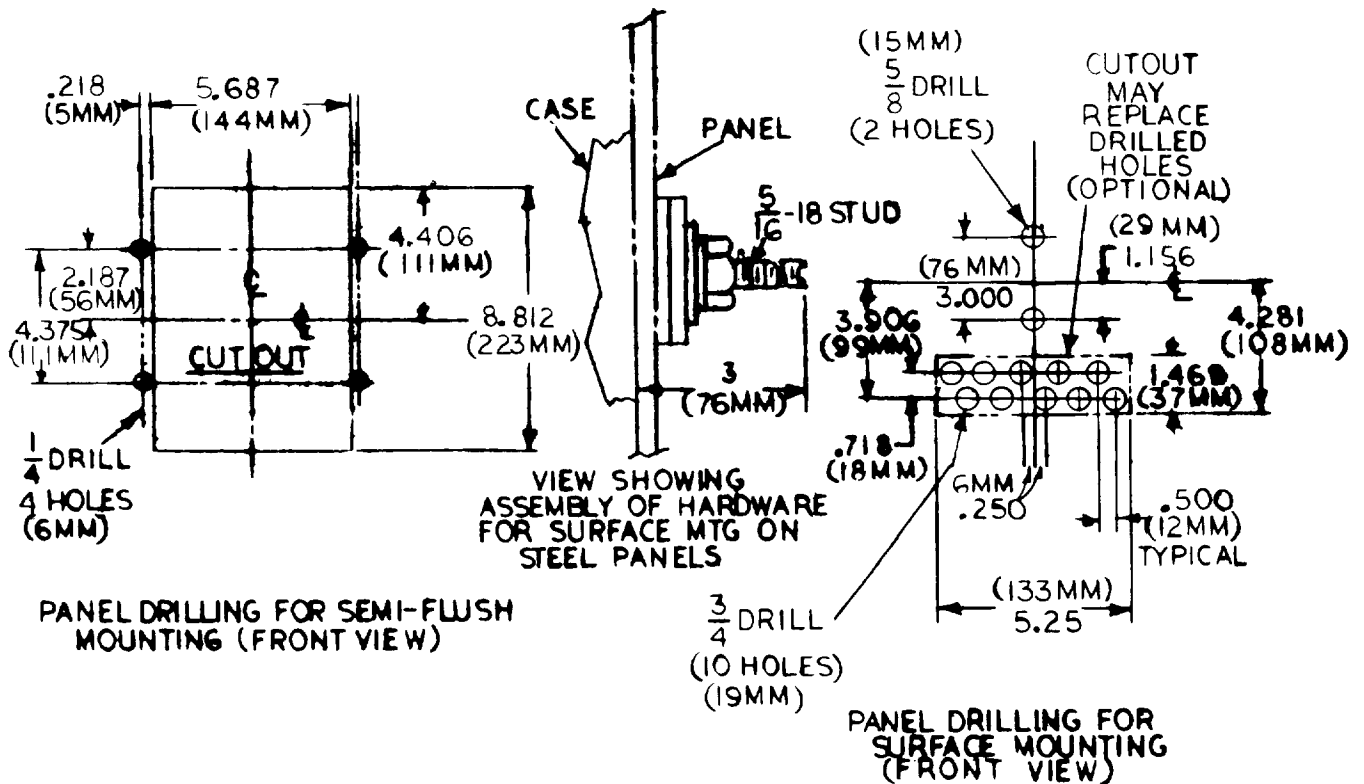
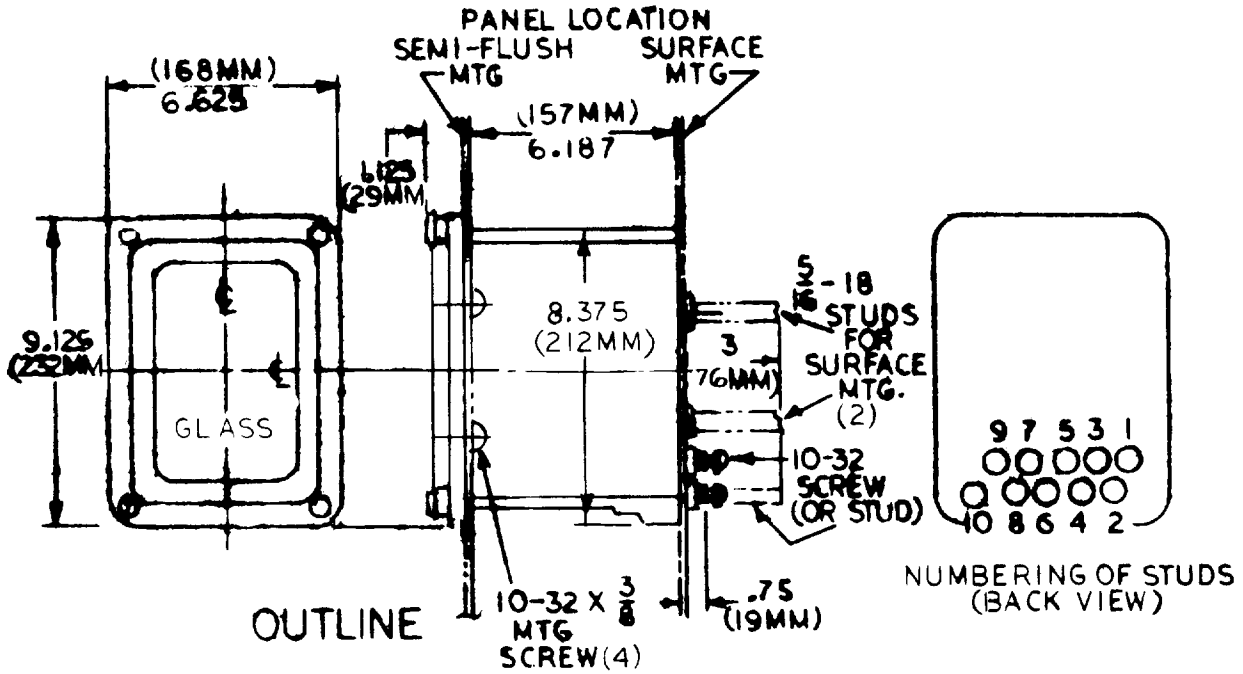
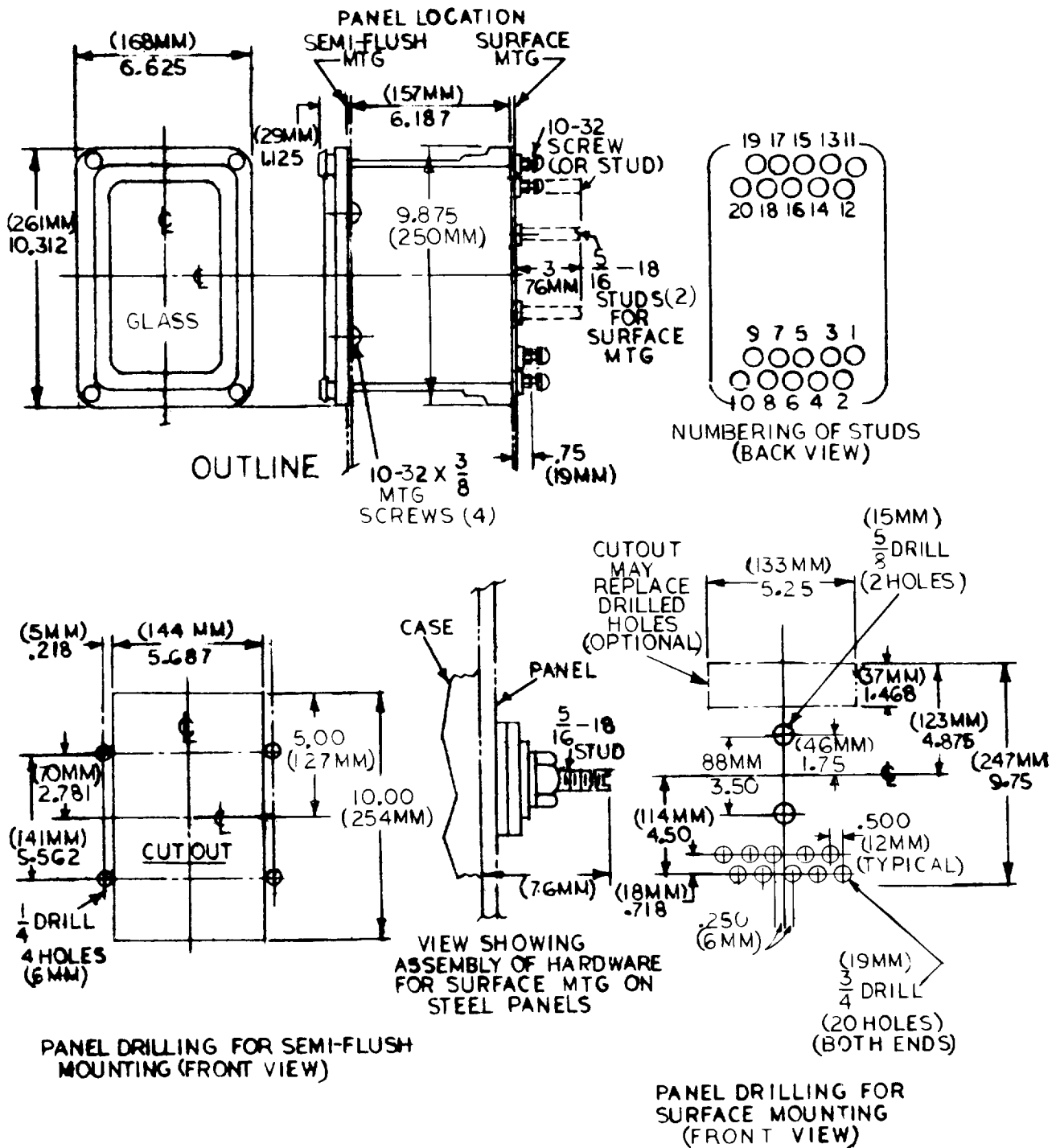

Fig. 3 (K-6209271-6) Outline and Panel Drilling for Size S1 Case



* Fig. 4 (K-6209272-5) Outline and Panel Drilling for Size S2 Case

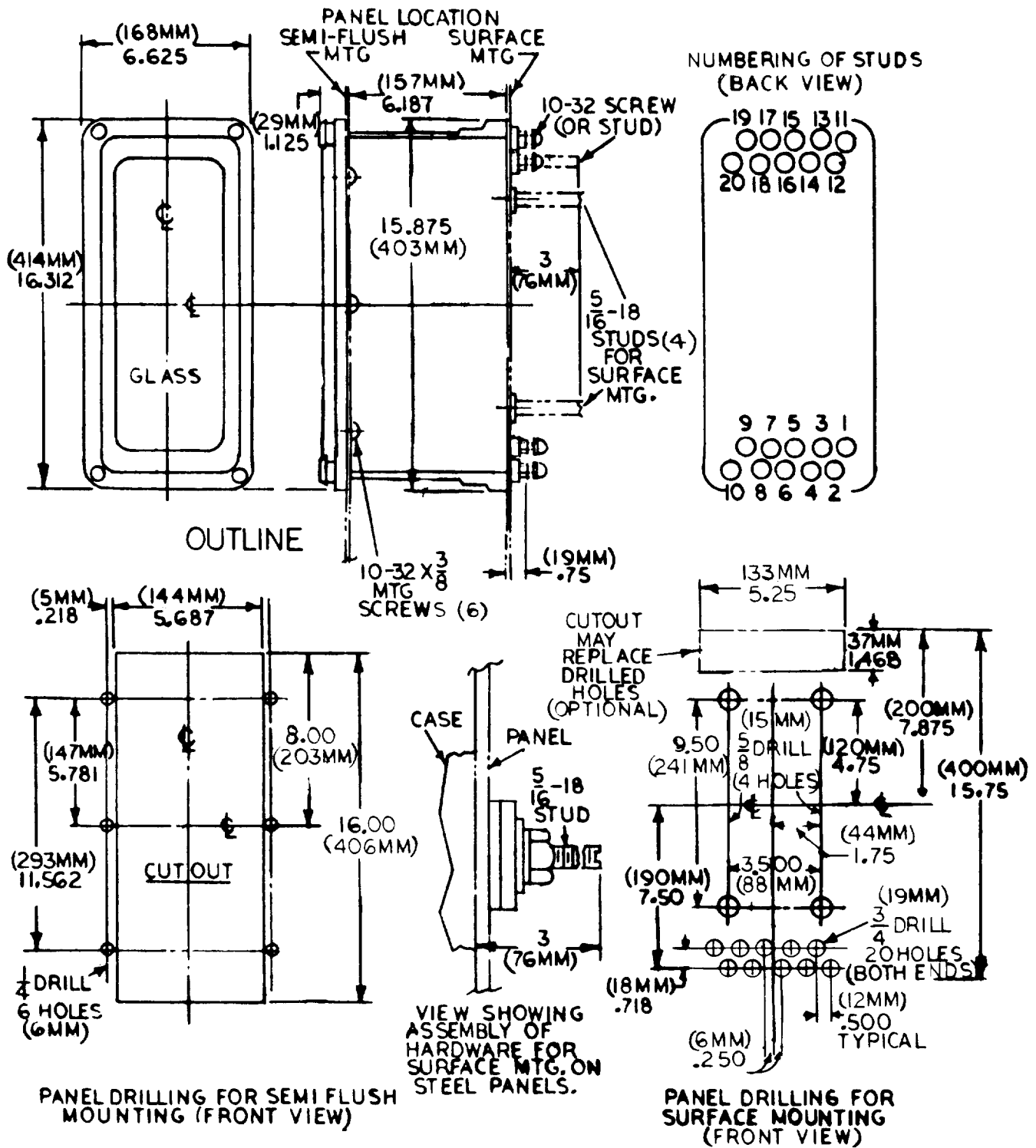

Fig. 5 (K-6209274-4) Outline and Panel Drilling for Size M2 Case

*

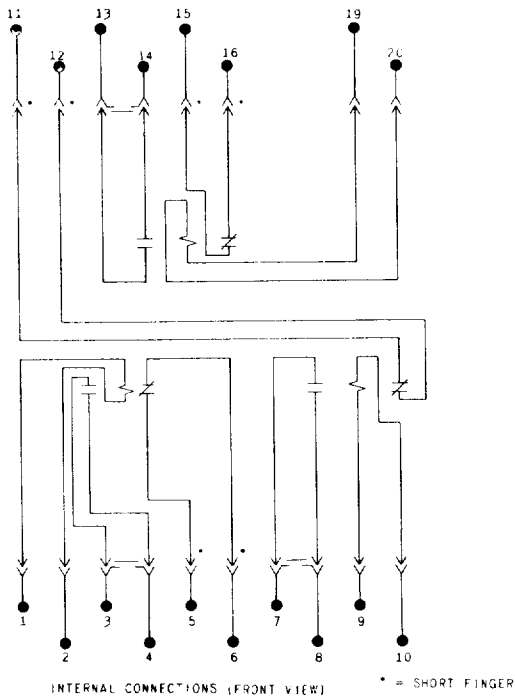

Fig. 6 (K-6209549-2) Internal Connections for Types PJV11J, PJV11N, PJV12C (Front View)

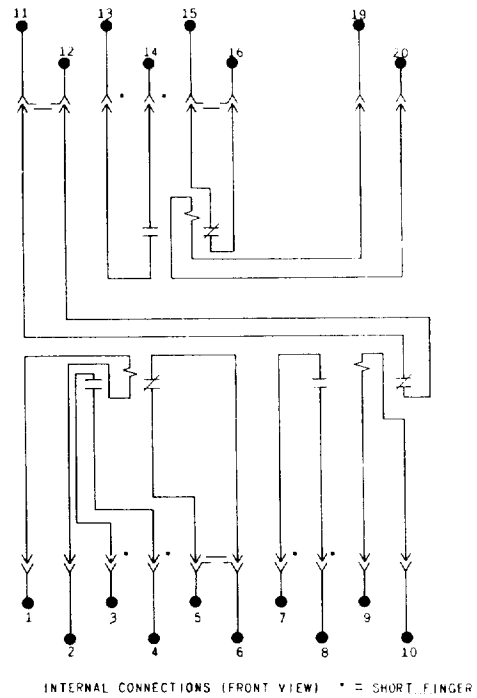
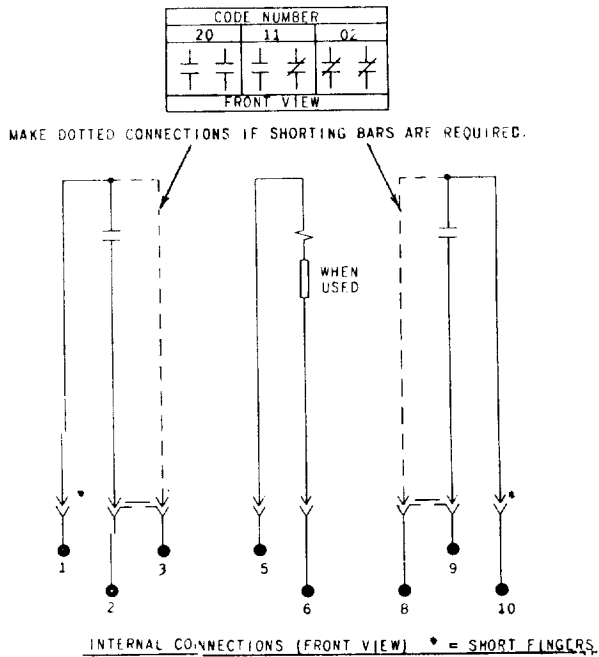

Fig. 7 (K-6375673-1) Internal Connections for Type PJV11AR (Front View)



*Fig. 8 (K-6209299-6) Internal Connections for Types PJV11L, PJV11AF, PJV11AK, PJV11AM, PJV11AW, PJV11BF, PJV12B (Front View)

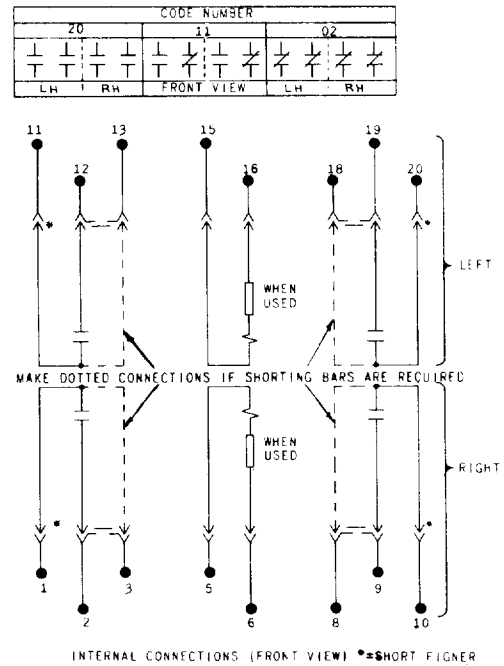

Fig. 9 (K-6375603-4) Internal Connections for Types PJV11AH, PJV11AJ, PJV11AL, PJV11AN, PJV11AT, (Front View)

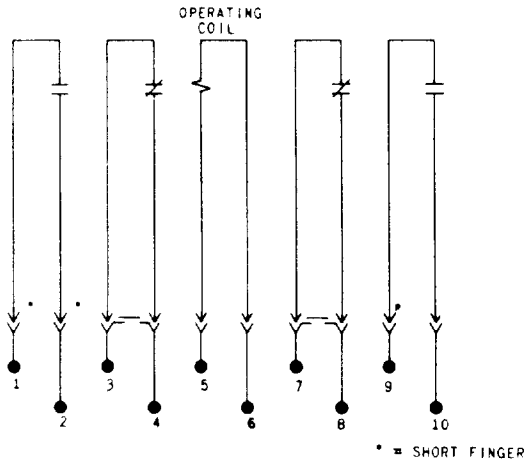

Fig. 10 (K-6154896-0) Internal Connections for Type PJV15A (Front View)

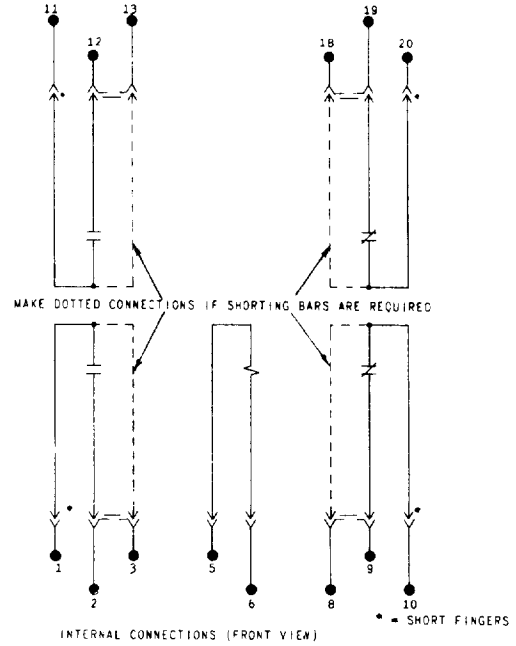

Fig. 11 (K-6375602-3) Internal Connections for Types PJV14B and PJV14C (Front View)

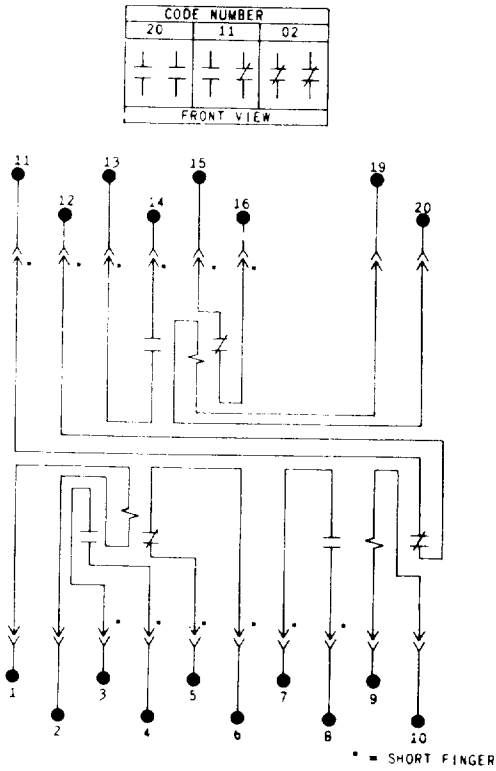

Fig. 12 (K-6375702-0) Internal Connections for Type PJV11AS (Front View)

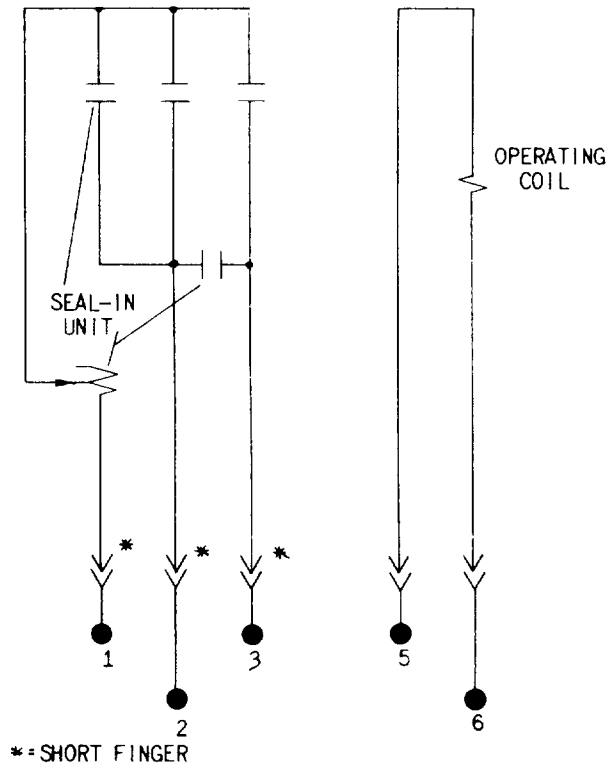

Fig. 13 (418A773-0) Internal Connections for Type PJV11AZ (Front View)



GE Power Management

**215 Anderson Avenue
Markham, Ontario
Canada L6E 1B3
Tel: (905) 294-6222
Fax: (905) 201-2098
www.ge.com/indsys/pm**