



# INSTRUCTIONS

**PLS1B55A1UL2XB021  
PLS1B55A2UL2XB022  
PLS1B55A1UB2XB032**

## **HYBRID SCHEME WITH DUAL FSK CHANNELS and PHASE IDENTIFIED LOGIC**

### **INTRODUCTION**

These instructions, GEK-100658 together with GEK-90672, constitute the complete instructions for the above relays.

### **DESCRIPTION**

These relays have the following differences from the standard PLS relay described in GEK-90672.

1. Revised DLA and Alarm contact outputs and revised Test Plug PT inputs. See Elementary Drawing 0145D8876.
2. ULM194 module contains a link used to disable the PD1 and ND functions from tripping Zone 1. See Module Diagram 0286A5320 and Logic Diagram 0145D8878.

### **ATTACHMENTS**

Figure 1 (0286A5320) ULM194 Module Layout  
Figure 2 (0145D8878) Logic Diagram  
Figure 3 (0145D8876) Elementary Diagram

*These instructions do not purport to cover all details or variations in equipment nor provide for every possible contingency to be met in connection with installation, operation or maintenance. Should further information be desired or should particular problems arise which are not covered sufficiently for the purchaser's purposes, the matter should be referred to the General Electric Company. To the extent required the products described herein meet applicable ANSI, IEEE and NEMA standards; but no such assurance is given with respect to local codes and ordinances because they vary greatly.*

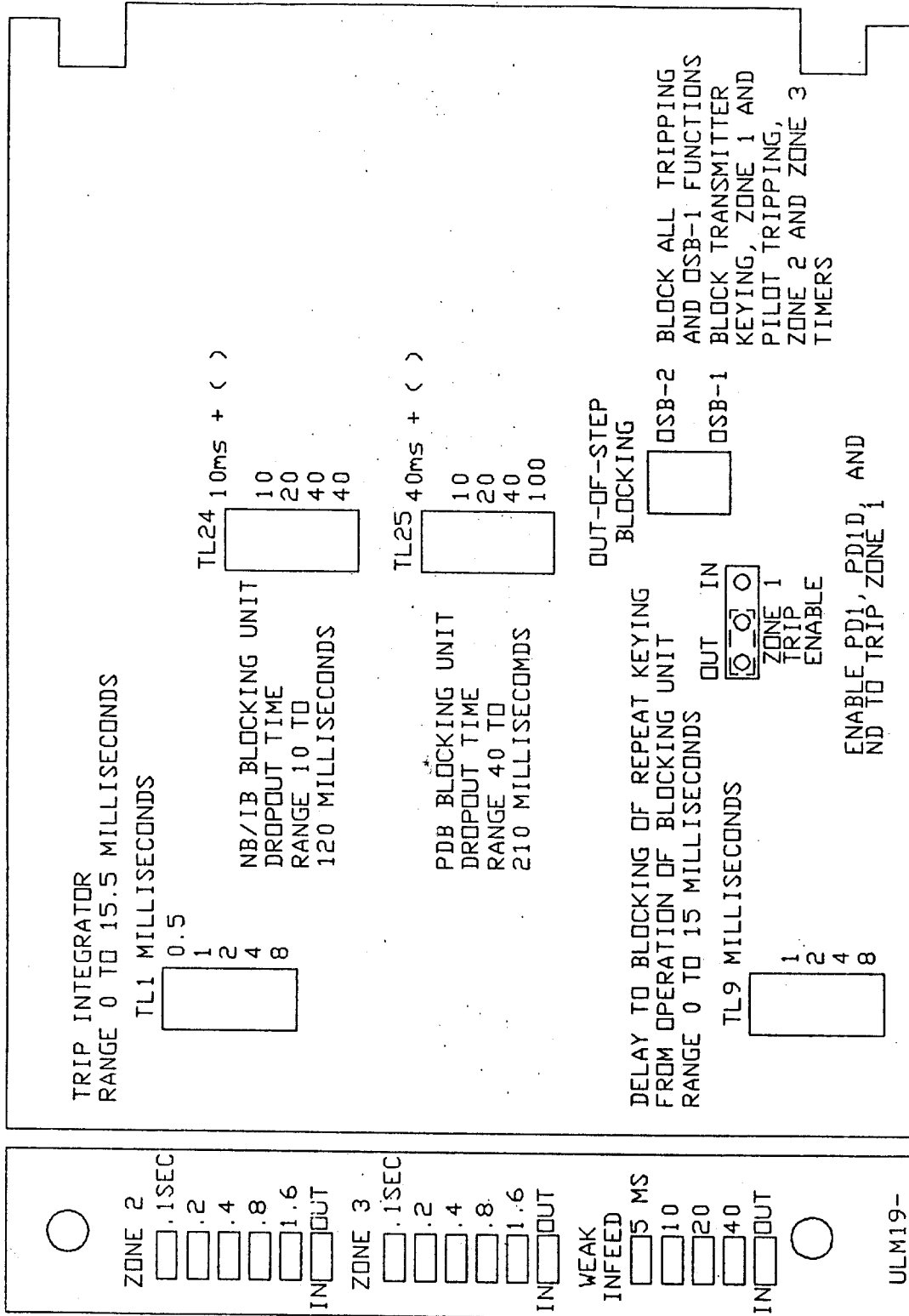

Figure 1 (0286A5320) ULM194 Module Layout



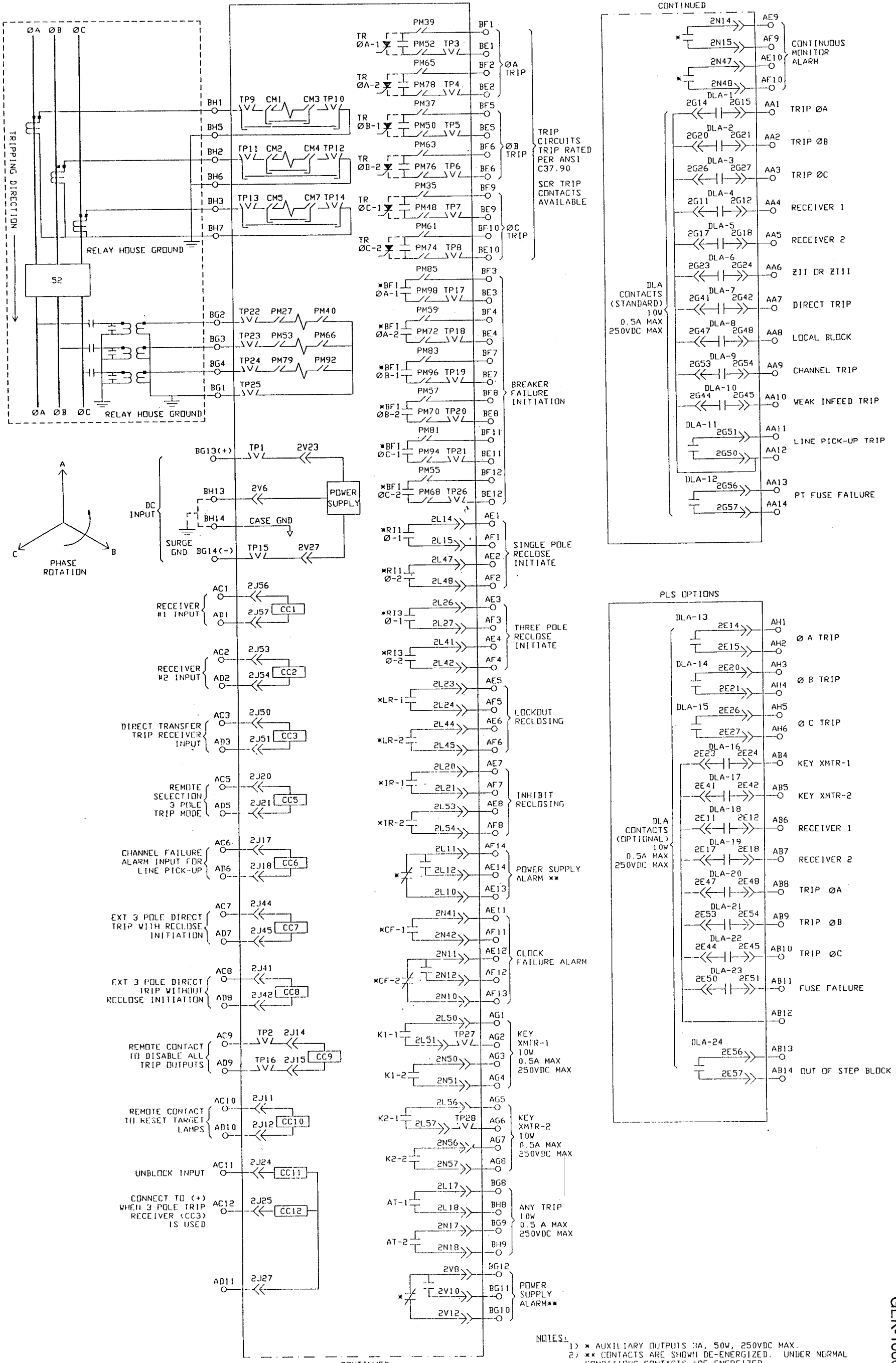

Figure 3 (0145D8876 [1]) Elementary Diagram

(12/94) (50) General Electric Protection and Control Technology Center, Malvern, PA 19355 USA

- NOTES:
- 1) \* AUXILIARY OUTPUTS 3A, 50W, 250VDC MAX.
  - 2) \*\* CONTACTS ARE SHOWN DE-ENERGIZED. UNDER NORMAL CONDITIONS CONTACTS ARE ENERGIZED.
  - 3) SEE GE DWG. 0286A2774 FOR MNEMONIC DEFINITION LEGEND
  - 4) SEE GE DWG. 0286A2774 FOR SYMBOL DEFINITION LEGEND
  - 5) --- USER CONNECTION

GEK-100658