



INSTRUCTIONS

GEK-7301H
Supersedes GEK-7301G

POWER SENSOR TEST SET TYPES PST-1 AND PST-1-1

**FOR TESTING POWER SENSOR TRIP DEVICES TYPES PS-1, PS-1A, PS-1A-1
USED ON LOW VOLTAGE POWER CIRCUIT BREAKERS
TYPES AK-25/50/T50/75/100 AND AKR-50**

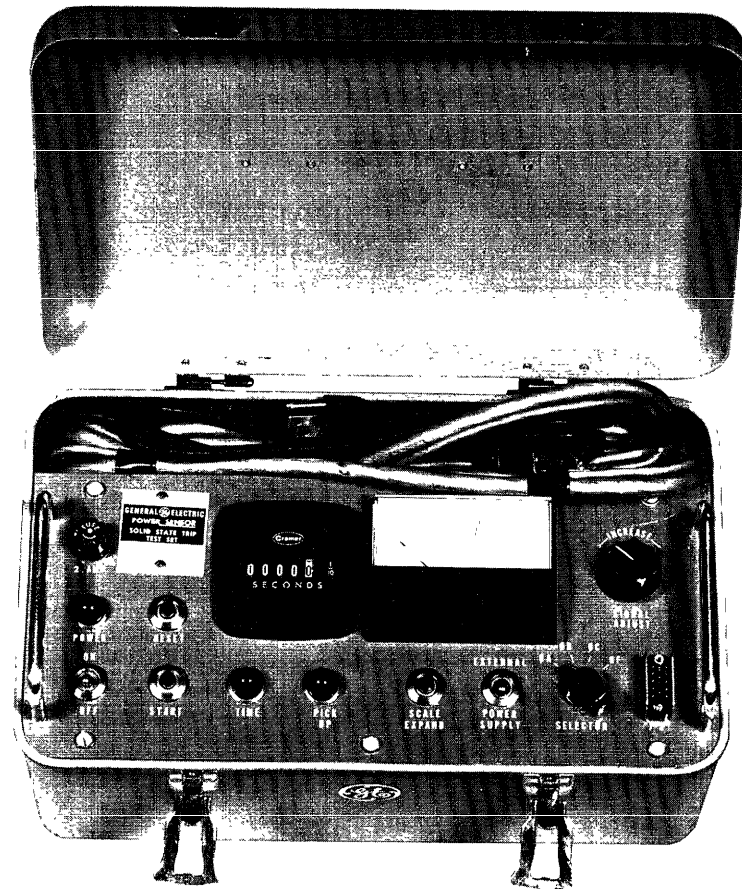

GENERAL  ELECTRIC

INDEX

Disassembly of Blank Compartment	2
Disassembly of Rear Barrier	3
Assembly of AKR Compartment	4
Assembly of Base to Rear Posts, and Assembly of Riser	5
Bus with Splice Bus Alignment Check & Torque Information	6

NOTE — Follow steps in sequence for both
disassembly and assembly.



WARNING: DO NOT ATTEMPT DISASSEMBLY OR ASSEMBLY
OF EQUIPMENT WITH POWER ON.

HAZARDOUS VOLTAGE CAN SHOCK, BURN, OR CAUSE
DEATH.

TURN OFF POWER BEFORE SERVICING THIS DEVICE.

CONTENTS

	<u>Page</u>
INTRODUCTION	3
PART I – TEST CONNECTIONS A OR B	3
A-Connection	3
B-Connection	4
PART II – TESTING SEQUENCE	4
General	4
Pick-up Tests	4
Time Delay Tests	5
Breaker Trip Circuit Test	5
Power Supply Unit Voltage Test	5
After Completion of Tests	6
Time-Current Curves	6
APPENDIX	11
Description of Test Set	11
Operating Notes	11

These instructions do not purport to cover all details or variations in equipment nor to provide for every possible contingency to be met in connection with installation, operation or maintenance. Should further information be desired or should particular problems arise which are not covered sufficiently for the purchaser's purposes, the matter should be referred to the General Electric Company.

DISASSEMBLY OF BLANK COMPARTMENT

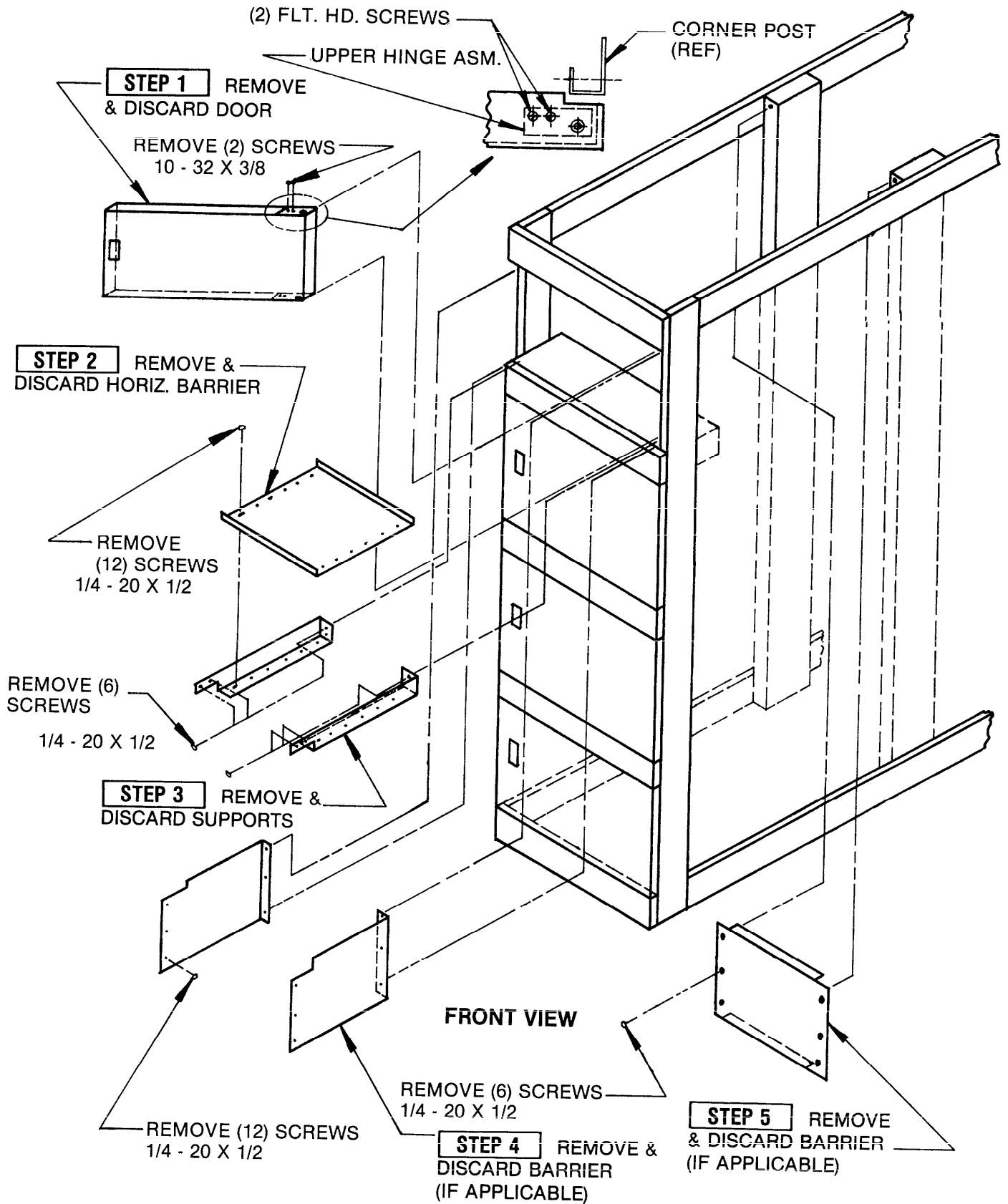

NOTE: "A" COMPARTMENT SHOWN, SIMILAR DISASSEMBLY FOR "D" COMP'T.

POWER SENSOR TEST SET

TYPES PST-1 AND PST-1-1

FOR TESTING POWER SENSOR TRIP DEVICES

TYPES PS-1, PS-1A, PS-1A-1

INTRODUCTION

The Types PST-1 and PST-1-1 Power Sensor Test Set is a portable unit designed to facilitate on-site testing of Types AK-25/50/75/100 and AKR-50 low-voltage power circuit breakers equipped with the Power Sensor solid-state overcurrent trip device.

The initial Test Set Model is designated PST-1 and is rated for source voltages between 115 and 125 Volts, 60 Hertz. The later model, designated PST-1-1, offers improved performance on source voltages below 115 Volts. Its operating range is 105-125 Volts, 60 Hertz. Except for their schematic diagrams (Figs. 5 and 6), the following description and test procedures apply to both units.

The Power Sensor Test Set is designed to:

1. Check current pick-up at the various level settings adjustable on the front escutcheon of the Power Sensor Logic Unit.
2. Check the time current characteristics of the long time delay bands. These are selective as maximum-intermediate-minimum on the front escutcheon of the Logic Unit.
3. Test the Logic Unit as a separate item, independent of the breaker and its current sensors.
4. Test the combination of Logic Unit, Power Supply Unit, Magnetic Trip device and associated control wiring while installed in a de-energized breaker. The Power Sensor Trip Device will trip a closed breaker during this test.
5. Check load carrying by applying 0.8 per unit of setting for sufficient time. (500 seconds for minimum time band.)
6. Check time delay bands of the short time and ground fault elements. This procedure provides a rough indication only.

The Test Set does not check the current sensor coils, either as independent elements or as system components. The sensor coils may be checked via high-current, low-voltage testing of the complete

breaker using commercially available high-current test sets.

Factory production tests on the Power Sensor components are performed on accurate sine-wave sources. Distorted input voltages to the Test Set can cause deviations in the timing test results.

CAUTION: BEFORE INSPECTION OR ANY MAINTENANCE WORK IS DONE, BE SURE THAT THE BREAKER IS IN THE OPEN CONTACT POSITION. ALL ELECTRICAL POWER, BOTH PRIMARY AND CONTROL SOURCES, SHOULD BE DISCONNECTED. THE TEST BREAKER SHOULD HAVE BEEN CHECKED BY RECOMMENDED INSTALLATION AND MAINTENANCE PROCEDURES BEFORE STARTING ANY TESTING.

PART I — TEST CONNECTIONS A OR B

A-CONNECTION (FIG. 1)

This connection is used to test the Power Sensor Logic Unit independently of other system components.

1. Connect Plug P1 to the Logic Unit.
2. Connect Plug P3 to engage Plug P4.
3. Set POWER SUPPLY position on the dc source selector switch.
4. Follow Part II – Testing Sequence of these instructions.

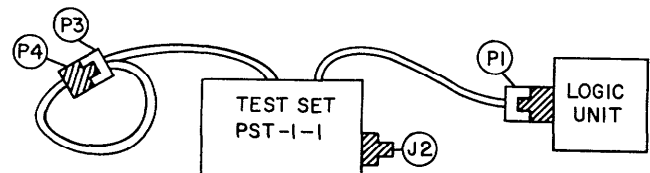
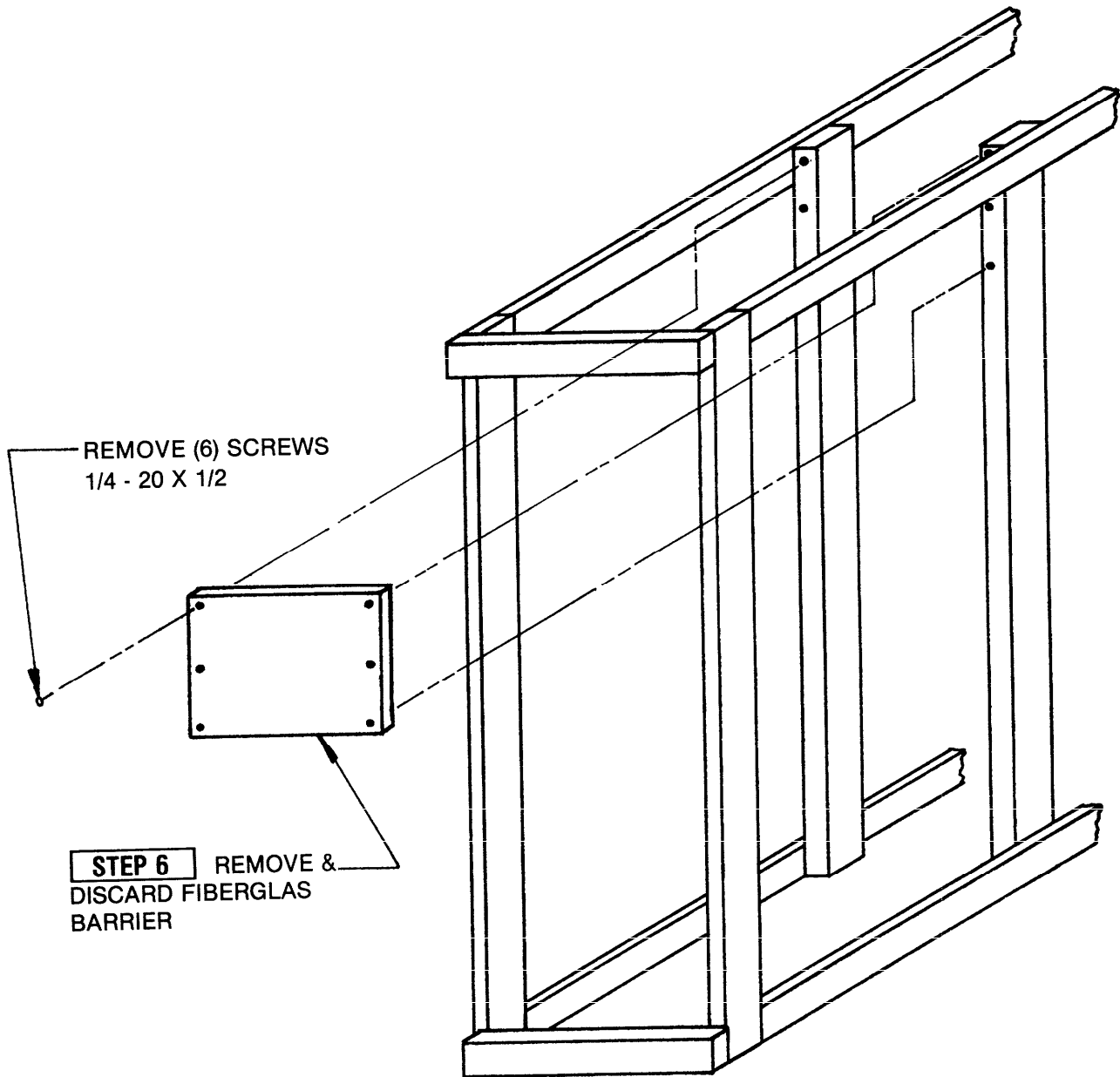

Fig. 1. "A" Test Connection
(Tests Logic Unit Only)

DISASSEMBLY OF REAR BARRIER



REAR VIEW

NOTE: "A" COMPARTMENT SHOWN, SIMILAR DISASSEMBLY FOR "D" COMP'T.

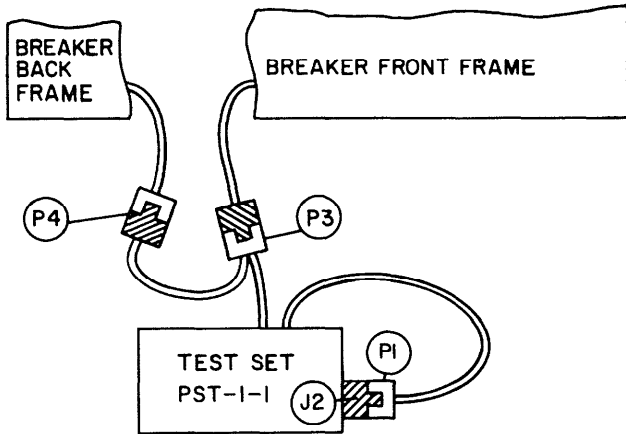

Fig. 2. "B" Test Connection
(Tests Logic Unit, Power Supply and Trip Device)

B-CONNECTION (FIG. 2)

This connection is used to test the Logic Unit, Power Supply Unit, Magnetic Trip Device and cabling while mounted on a de-energized breaker.

1. Connect Plug P1 to Panel Connector J2.
2. Separate the disconnect in the breaker located between power sensor wiring on the front frame and the wiring on the back frame. See Fig. 3.
3. Connect Plug P4 to the disconnect section wired to the back frame. Connect Plug P3 to the disconnect section wired to the front frame.
4. Set EXTERNAL position on dc source selector switch.
5. Follow Part II - Testing Sequence of these instructions.

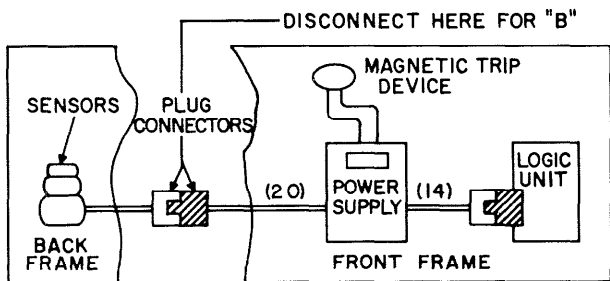

Fig. 3. Power Sensor Cabling and Disconnect Plugs
(Breaker in Service)

PART II — TESTING SEQUENCE

GENERAL

Connect Test Set to 120 Volt ac, 60 Hertz source by means of the appliance cord P5. Throw Power Switch to the ON position. Rotate variable transformer knob fully counterclockwise.

Set dc source selector on the desired position — POWER SUPPLY or EXTERNAL per Part I instructions.

PICK-UP TESTS

NOTE: Refer to Table 2 for acceptable Test Tolerances.

Long Time

1. Push mechanical reset of timer.
2. Push Electrical RESET Button. Repeat reset until both time and pick-up indicating lights are out.
3. For overcurrent check, select the phase to be tested, or select ground connection to be tested for ground fault.
4. Push START Button.
5. Rotate SIGNAL ADJUST knob clockwise. Watch the meter for value at which pick-up indicating light shows. If desired, operate the SCALE EXPAND Switch to allow closer readings for range of values less than 1.5 per unit.
6. Move the pick-up selector screw on logic unit to each value and repeat test. Range of values is 0.8 to 1.3 per unit. Repeat at one selected value on other phases.

Short Time

1. Push electrical RESET Button.
2. Move SELECTOR Switch to phase to be tested.
3. Set the Logic Unit instantaneous pickup screw to MAXIMUM. Set short time band selector screw to MINIMUM.
4. Adjust the SIGNAL ADJUST knob until the meter indicates a value more than 10 percent below the pick-up point under test.

ASSEMBLY OF BREAKER COMPARTMENT

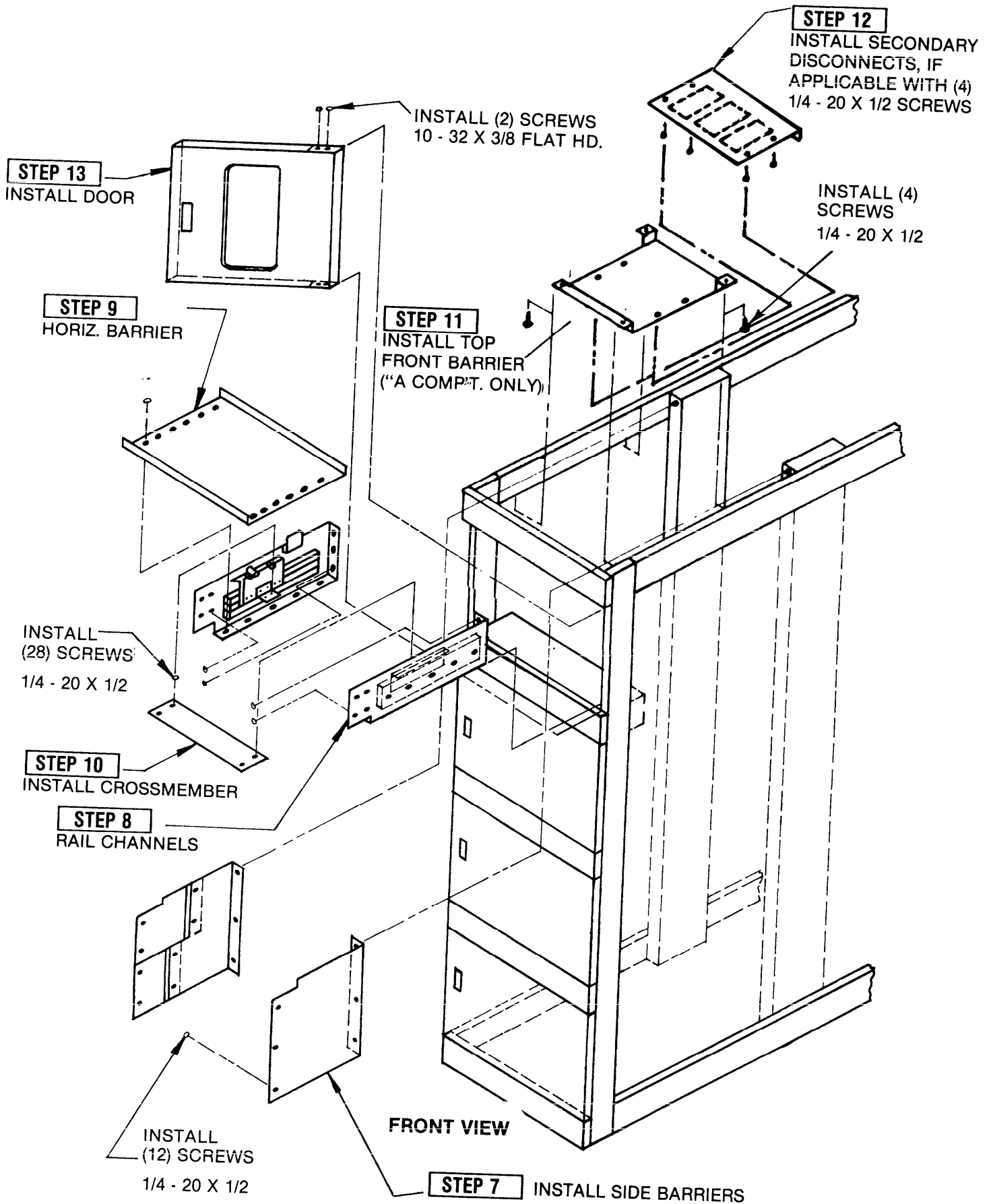

NOTE: "A" COMPARTMENT SHOWN, SIMILAR ASSEMBLY ON "D" COMPARTMENT.

5. Push the START Button.

6. Immediately raise the signal value by clockwise rotation of SIGNAL ADJUST knob. Observe value on meter when interlock circuit removes power from the meter. Refer to Test Tolerance in Table 2.

7. Repeat test for each pick-up setting. If other phases were not checked in long time delay test, check one point on each phase.

Instantaneous

1. Push electrical RESET Button.

2. Set signal to value 10 percent below point undergoing test.

3. Reset Timer.

4. Push START Button.

5. Note that timer operated.

6. Push electrical RESET Button.

7. Set signal to value of 10 percent above point undergoing test.

8. Push the START Push Button. Observe very slight movement of the timer. Also, the test power will be removed from the meter.

9. Repeat test for each setting. Check one point on each of the other phases.

Ground Fault

1. Set the Selector to GF.

2. Start with SIGNAL ADJUST knob fully counterclockwise.

3. Push electrical RESET Button.

4. Push START Button.

5. Raise signal until the power to meter is removed. Refer to Test Tolerance in Table 2.

6. Repeat test for each Ground Fault pick-up setting.

TIME DELAY TESTS

NOTE: Refer to Table 3 for acceptable test limits.

Long Time

1. Push electrical RESET Button.

2. Reset Timer.

3. Select the phase to be tested.

4. Set the signal level to the desired value. (See Table 3.)

5. Push the START Button. Time indicating lamp lights. Pick-up indicating lamp lights. The timer is clocking time.

6. Power is removed from signal meter at the trip time. Read timer, and check Table 3 for the time-current values.

7. Repeat test at other signal levels and other time bands as desired.

Short Time and Ground Fault

The Short Time and Ground Fault timing tests are performed the same way as for Long Time. Ignore the time and pick-up indicating lights as they provide no useful information in this test.

The intervals of time involved are so small that the timer only roughly indicates the time band selected.

BREAKER TRIP CIRCUIT TEST

1. Use the cable connections described under Part I - Test Connection B.

2. Close the disconnected breaker.

3. Perform any time delay or instantaneous test described in these instructions. Circuit Breaker will trip.

POWER SUPPLY UNIT VOLTAGE TEST

1. Use cable connection B.

2. Open the breaker.

3. Set SIGNAL ADJUST knob fully counterclockwise. Push RESET and START buttons.

INSTALLATION OF BASE ASSEMBLY AND RISER BUS SPLICE

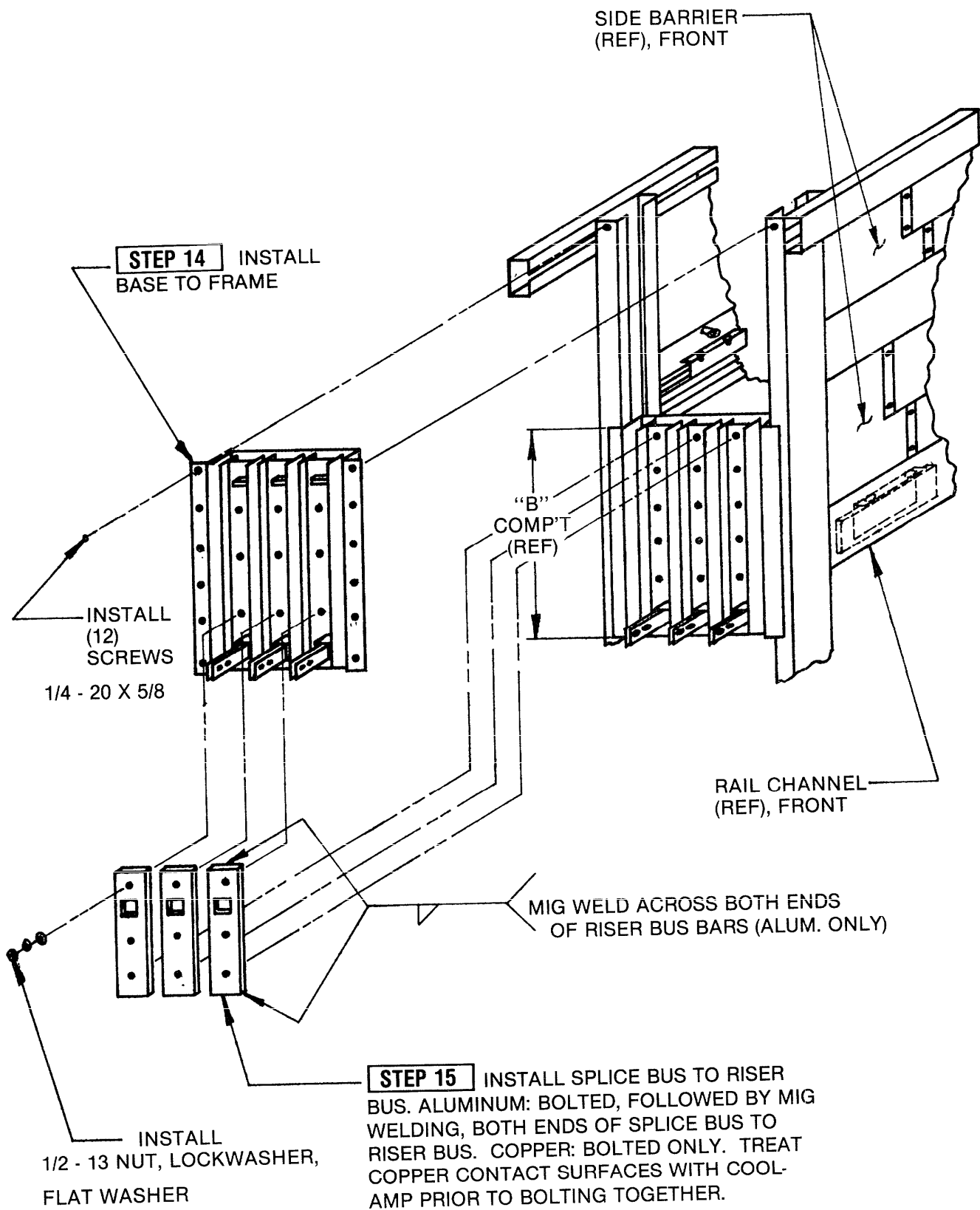

REAR VIEW

NOTE: "A" COMPARTMENT SHOWN, SIMILAR ASSEMBLY FOR "D" COMPARTMENT.

GEK-7301, Power Sensor Test Set

4. With a dc voltmeter, check for 100 volts dc at the terminals of the 110 mfd. electrolytic capacitor. Measure this voltage on phases A, B and C by rotating the selector knob. If the voltage is not within the limits of Table 1, the power supply is defective and must be replaced.

On AK-25 breakers this capacitor is located on the lower left corner of the backframe next to the CT disconnect plug. On AK-50/75/100 breakers it is located on the bottom of the Power Supply Unit. On AKR-50 breakers it is located behind the Power Supply Unit.

TABLE 1
POWER SUPPLY VOLTAGE LIMITS

BREAKER TYPE	POWER SUPPLY CATALOG NUMBER	PERMISSIBLE RANGE DC VOLTS
AK-25	121C7519 G1	95 - 115
	156C4508 G1	95 - 115
	156C4508 G10	92 - 106
AK-50/75/100	121C7521 G1	95 - 115
	152C9262 G1	95 - 115
	152C9262 G10	92 - 106
AKR-50	108D8102 G1	95 - 115
	108D8102 G10	92 - 106

AFTER COMPLETION OF TESTS

- Carefully reconnect all disconnect plugs.

CAUTION: CHECK THAT THE THREE CURRENT SENSOR TAP SELECTORS ARE IN PLACE. FAILURE TO CARRY OUT THIS INSTRUCTION WILL DEFEAT THE BREAKER'S AUTOMATIC TRIP SYSTEM.

WARNING: HIGH TEST CURRENTS FLOWING THROUGH THE BREAKER WITH SENSOR TAPS OPEN-CIRCUITED WILL CAUSE EXCESSIVE VOLTAGES CAPABLE OF DAMAGING THE COIL INSULATION.

- Restore all Logic Unit settings to their original "AS RECEIVED" values.

TIME-CURRENT CURVES

- Long Time, Short Time and Instantaneous: GES-6021A.
- Ground Fault: GES-6031. Use GES-6030 for PS-1 units manufactured prior to May 1973.

TABLE 2

ACCEPTABLE PICK-UP LIMITS

LONG TIME			SHORT TIME				INST.		GROUND				
Set	Expand Scale	Normal Scale	Set	± Div.	Set	± Div.	Set	± Div.	Set		PS-1 ± Div.	PS-1A, PS-1A-1 - Div.	
	± Div.	± Div.											
1.3	8.0	2.15	5.0	4.0	10	6.5	12	7.5	4	12	30	7.5	15
1.2	7.5	2.1	4.0	3.5	8	5.5	10	6.5	3	9	22.5	6.0	12
1.1	7.0	2.05	3.5	3.25	7	5.0	8	5.5	2	6	15	4.5	9
1.0	6.5	2.0	3.0	3.0	6	4.5	6	4.5	1	3	7.5	3.0	6
0.9	6.0	1.95	2.5	2.75	5	4.0	5	4.0					
0.8	5.5	1.9	2.0	2.5	4	3.5	4	3.5					

NOTE: The above tolerances reflect a Test Set signal level meter accuracy of ± 2 percent full scale and a ± 10 percent pickup tolerance for the Power Sensor.

The tolerance is expressed in plus or minus divisions on the meter scale.

Set denotes the pickup settings as marked on the selector nameplate of the Logic Unit.

STEP 16 check location dimensions for alignment after assembly. Refer to:

AKR 30/50 Compartment	-75D165249 Sh. #1
AKR 30/59 Ext. Compartment	-75D165249 Sh. #2
AKRU 30/50 Compartment	-75D165249 Sh. #3
AKR 30/50 Intermix Compartment	-75D165249 Sh. #4
AKR 30/50 Ext. Intermix Compartment	-75D165249 Sh. #5
AKRU 30/50 Intermix Compartment	-75D165249 Sh. #6
Secondary Disconnects	-75C149315 Sh. #29

Torque values are as follows:

1/4-20 Hdw. = 7-10 ft. lbs.

1/2-13 Hdw. = 35-40 ft. lbs.

STEP 17 install circuit breaker. Refer to low voltage switchgear instructions GEH-4674, Section V, pages 54-59.

STEP 18 Install power cables. Refer to instructions, Section IV, page 50.

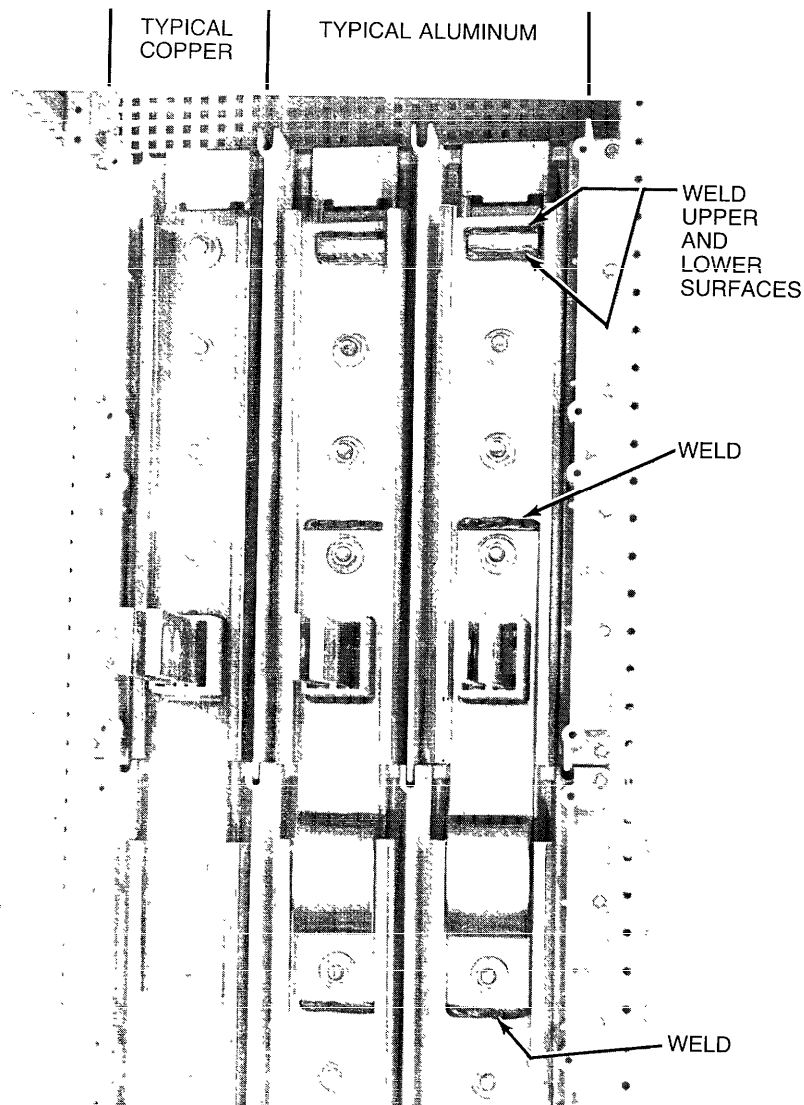

REAR VIEW
(TOP COMPARTMENT ILLUSTRATED)

TABLE 3
ACCEPTABLE TRIPPING TIMES

SIGNAL LEVEL READINGS ON METER	LONG TIME DELAY* (Seconds)		
	Max.	Inter.	Min.
1.5	420-780	210-390	70-130
2	236-439	118-220	39-73
3	105-195	53-98	18-33
4	59-110	30-55	10-18
5	38-70	19-35	6-12
6	26-49	13-25	4.4-8.2
7	19-36	10-18	3.2-6.0
8	15-28	7-14	2.5-4.6
9	12-22	6-11	1.9-3.6
10	9.5-18	4.7-9	1.6-3.0

*Tripping times differ from published time-current curves to allow for variations in field test facilities. When setting signal levels, be sure they are not on the low side during any part of the timing test.

(FOR REFERENCE ONLY)

SHORT TIME DELAY (Seconds)	
Max.	0.325-0.50
Int.	0.16-0.30
Min.	0.07-0.15

(FOR REFERENCE ONLY)

GROUND FAULT DELAY (Seconds)	
0.06	0.054-0.135
0.12	0.115-0.195
0.18	0.165-0.270
0.24	0.220-0.355
0.30	0.270-0.430

These instructions do not purport to cover all details or variations in equipment nor to provide for every possible contingency to be met in connection with installation operation or maintenance. Should further information be desired or should particular problems arise which are not covered sufficiently for the purchaser's purposes, the matter should be referred to the General Electric Company.

For further information
call or write your local
General Electric
Sales Office or . . .

General Electric
Distribution Equipment
41 Woodford Avenue
Plainville, CT 06062

- CABLE CONNECTORS
 INPUT 115 VOLTS 60 HZ THREE PRONG-WITH GROUND
 P-1 CABLE-ONE CONNECTOR
 P-1 14 SOCKETS-FEMALE
 P3/P4 CABLE-TWO CONNECTORS
 P-3 20 SOCKET-FEMALE
 P-4 20 PINS-MALE
 J-2 FIXED CONNECTOR
 14 PINS-MALE

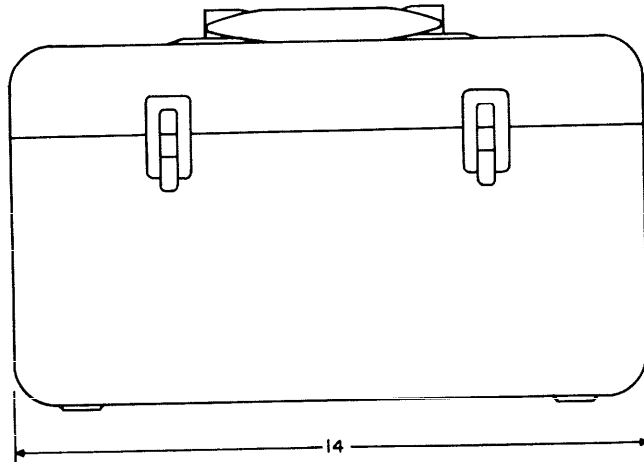
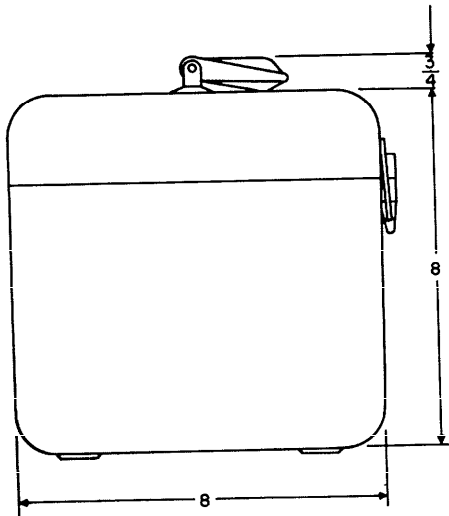
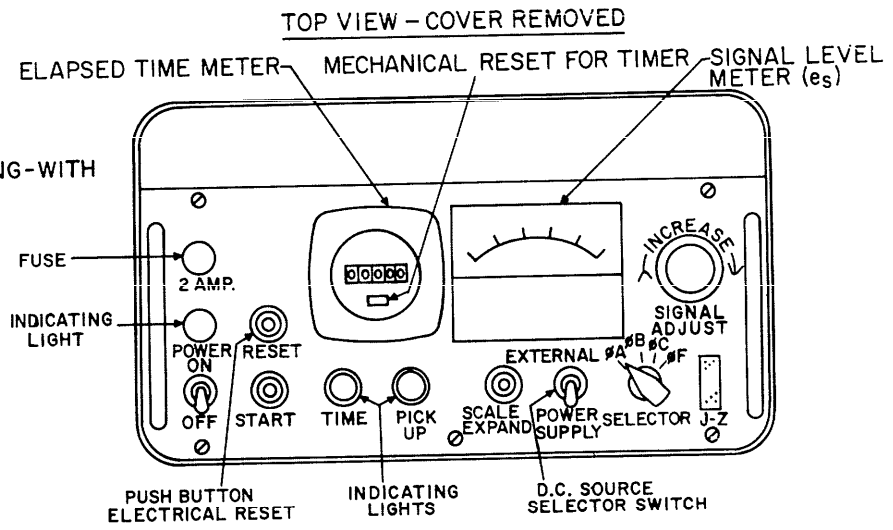

Fig. 4. Test Set Outline (0132C2639)

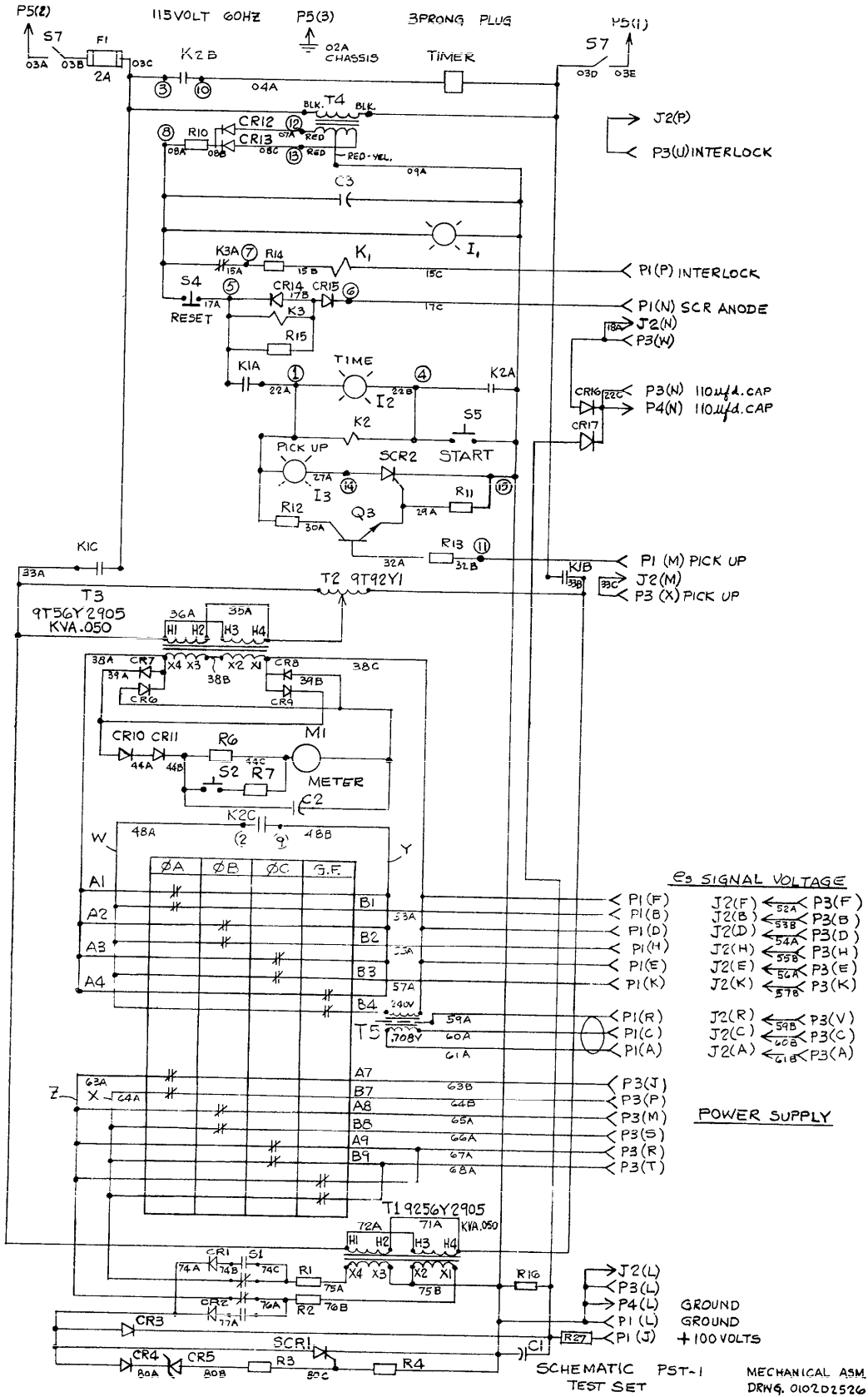

Fig. 5. Schematic PST-1 Test Set (184L380)

GEK-7301, Power Sensor Test Set

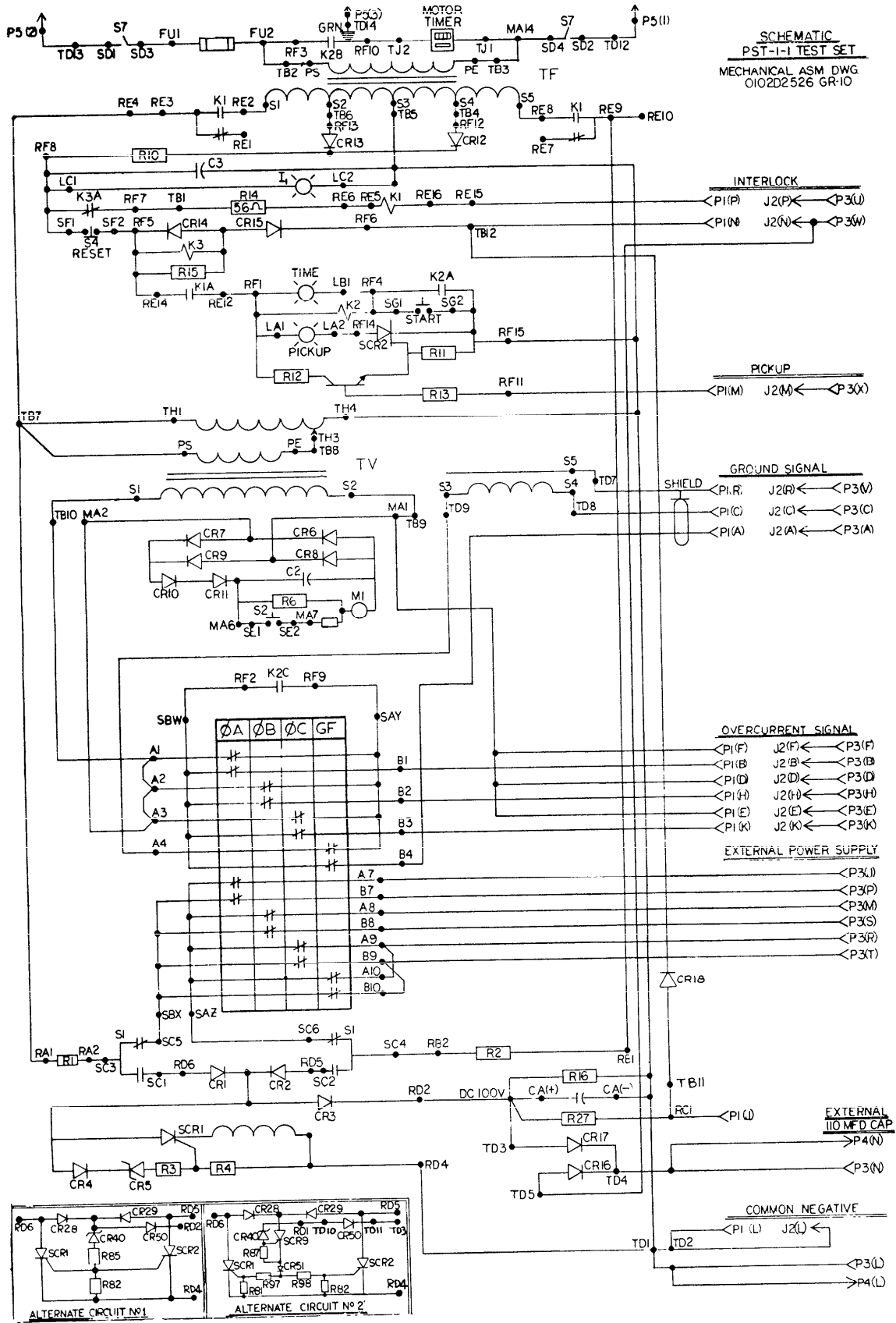

Fig. 6. Schematic PST-1-1 Test Set (184L387)

APPENDIX

DESCRIPTION OF TEST SET

Outline is shown in Figure 4 and identifies the cable connectors. Schematic drawings Figs. 5 and 6 show the internal circuitry, switches and cable transfer arrangements.

OPERATING NOTES

1. Input voltage is obtained through connector P5 which is a three wire appliance cord with a ground conductor. The chassis and metal parts are connected to the ground conductor for the safety of the Test Set user.

2. Output voltages are isolated from the input voltage by means of iron core, multiple winding transformers.

3. All power to the Test Set passes through the on-off switch S7 and a two ampere fuse.

4. Relay K2 functions as a starting contactor for the timer. Relay K2 seals itself in through a contact of relay K1.

The signal voltage is applied to the Power Sensor system through Relay K2 (C Contact).

5. Relay K1 is the interlock relay which permits application of the test signal voltage contingent upon proper connection of the cables. Also, Relay contact K1A de-activates the timer power source through interlock with Relay K2.

6. Relay K3 is energized when the Power Sensor trip circuit is functioned. This action interrupts the interlock loop through the cables and de-energizes Relay K1. Relay K1 removes the signal voltage from the Power Sensor Unit.

7. The Phase Selector switch connects the signal voltage to the phase under test. The tests are performed single phase. Therefore, each phase is checked by advancing the Selector Switch. Do not move the phase selector while a test is in progress. Before moving the Phase Selector, push Reset button.

8. Switch S1 selects the source of dc power. When a Power Sensor Logic Unit is to be tested independently of the other system components (i.e., the A-Connection), the switch is positioned on POWER SUPPLY. In this mode the test set provides the dc power.

When the Logic Unit, Power Supply Unit and Trip Device are to be tested as a system (the B-Connection), the switch must be on EXTERNAL. In this mode the Power Supply Unit is activated and provides the dc operating voltage.

DISTRIBUTION EQUIPMENT DIVISION PLAINVILLE, CONNECTICUT

GENERAL  **ELECTRIC**