



INSTRUCTIONS

STATIC BREAKER AUXILIARY RELAY

TYPE SBA

*GE Meter and Control
205 Great Valley Parkway
Malvern, PA 19355-1337*

CONTENTS

	<u>PAGE</u>
DESCRIPTION	3
APPLICATION	3
RATINGS AND BURDENS	3
A. OPERATING VOLTAGE	3
B. SCR CURRENT RATINGS	4
C. REED RELAY CONTACT RATINGS	4
D. AMBIENT TEMPERATURE	4
CHARACTERISTICS	4
CONSTRUCTION	5
RECEIVING, HANDLING AND STORAGE	5
ACCEPTANCE TESTS	5
A. VISUAL INSPECTION	6
B. MECHANICAL INSPECTION	6
C. ELECTRICAL INSPECTION	6
INSTALLATION PROCEDURE	6
A. INTRODUCTION	6
B. TEST PLUGS	6
PERIODIC CHECKS AND ROUTINE MAINTENANCE	7
RENEWAL PARTS	7

STATIC BREAKER AUXILIARY RELAY

TYPE SBA

DESCRIPTION

The SBA is a high speed Static Breaker Auxiliary tripping relay with operating time of one (1) milli-second or less. The relay is equipped with either two tripping SCR outputs and two isolated reed relay outputs or four SCR outputs and four isolated reed relay outputs. The SBA relay can contain an optional internal circuit which will trip up to three parallel targets (either 0.2 or 2.0 amp) on external relays connected to trip through the SBA relay. The operating voltage can nominally be either 125 VDC or 250 VDC depending on the model selected.

APPLICATION

The SBA relay is intended for use wherever a high speed tripping relay is desired. The SCR outputs perform the high current tripping function. The reed relay outputs are intended to initiate a breaker failure relay such as a SAM11 or SBC21 relay, alarm, event recorder initiation, or any other low current relay output function. In any of these applications the current, voltage and equivalent effective capacitance should be within the rating of the reed relay contact. Because it is designed for intermittent tripping duty the output circuits, SCRs and reed contacts, are not rated for continuous duty. For details, refer to the section on RATINGS.

The external connection diagrams are shown in Figs. 1 and 2.

The SBA relay is supplied in an S2 type case. The case outline and panel drilling dimensions are shown in Fig. 9.

The SBA relay is highly resistant to seismic shock and vibration and passes a random multifrequency test at a 6 "g" Z PA level.

RATINGS AND BURDENS

Model No.	Voltage VDC	No. of trip outputs	No. of reed outputs	Provides circuit for tripping ext. targets	Standby burden watts/milliamps
SBA11A1A	125	2	2	NO	0
SBA11A2A	250	2	2	NO	0
SBA11B1A	125	2	2	YES	2.8/23.0
SBA11B2A	250	2	2	YES	5.7/23.0
SBA12A1A	125	4	4	NO	0
SBA12A2A	250	4	4	NO	0
SBA12B1A	125	4	4	YES	2.8/23.0
SBA12B2A	250	4	4	YES	5.7/23.0

OPERATING VOLTAGE

The operating voltage range for all models is 80 percent to 112 percent of nominal rating. For voltages below 60 percent of rating, the SBA outputs will not operate although targets may be operated if the operating input is energized by an external relay.

For models provided with means for tripping external targets, the operating contact (Terminal 5) should have at least 0.10 ohms in series. This can be a target coil or a group of target coils.

These instructions do not purport to cover all details or variations in equipment nor to provide for every possible contingency to be met in connection with installation, operation or maintenance. Should further information be desired or should particular problems arise which are not covered sufficiently for the purchaser's purposes, the matter should be referred to the General Electric Company.

To the extent required the products described herein meet applicable ANSI, IEEE and NEMA standards; but no such assurance is given with respect to local codes and ordinances because they vary greatly.

SCR CURRENT RATINGS

The voltage rating is either 125 VDC or 250 VDC, and is shown on the nameplate. SCR outputs will make and carry 30 amperes resistive load for at least 500 duty cycles at 20°C ambient with relay in case and cover secured. One duty cycle is:

ON	200 milliseconds
OFF	300 milliseconds
ON	200 milliseconds
OFF	15 seconds
ON	200 milliseconds
OFF	30 seconds
ON	200 milliseconds
OFF	120 seconds

Current is interrupted by external means at the end of each ON cycle. Make certain the proper polarity is observed on the SCR outputs.

REED RELAY CURRENT RATINGS

Reed relay contacts can make, carry and interrupt 150 milliamps resistive for 500 milliseconds at 250 VDC. Maximum shunt capacitance across the load is 0.05 microfarad at 250 VDC. For 125 VDC models, the maximum capacitance is 0.10 microfarad. For greater capacitance consult the factory for recommendations.

AMBIENT TEMPERATURE

These relays are designed for use in ambient temperatures between -20°C (-4°F) and +55°C (+131°F).

CHARACTERISTICSOPERATING PRINCIPLES

1. Operation of External Targets

Detailed schematics of all models are shown in Figs. 3 and 4. All other models are similar, but less complex. The operating principles are given for Model 12SBA12B2A shown in Fig. 4, which is a 250 VDC type with four trip and four reed outputs with target operation.

In the standby condition, terminal T7 is connected to the positive battery voltage and terminal T4 is connected to the negative battery voltage. Capacitor C1 is charged through resistor R1 until zener diode CR1 conducts and limits the capacitor voltage. C1 is used to discharge a high current through an external target which gives an indication of which external relay caused the trip operation. The capacitor C1 is normally charged to 10 volts with terminal T7 positive. The initial charging time is 45 seconds. Terminal T5 is connected in series with the external actuating relay contacts and the target coil as shown in Fig. 2. When the actuating relay contacts close, the capacitor C1 discharge current flows out of the T7 terminal, through the external target coil and closed relay contacts, into terminal T5, through diode CR3 and two normally closed relay contacts K1 back into the negative terminal of C1. The current is limited by the external target coil impedance. DO NOT OPERATE THE RELAY WITHOUT AT LEAST A 0.1 OHM RESISTANCE IN SERIES WITH TERMINAL T5. When terminal T5 is connected to the positive battery bus through the target coil and relay contacts, the T5 voltage is initially equal to the battery voltage less the 10 volt drop across C1. As C1 discharges, the T5 voltage rises toward the battery bus voltage. However, relay K1 is also energized and it picks up after 15 milliseconds and the normally closed pair of K1 contacts interrupt the capacitor current. The only current flowing into terminal T5 is due to the transistor Q1 and relay K1 circuits and is approximately 75 milliamps. When the current drops to 75 milliamps the target seal-in contacts will open and when the external actuating contacts open, the relay will be ready for the next trip operation. Diodes CR2 and CR3 limit the T5 terminal voltage to slightly more than the T7 terminal voltage when the target coil inductive energy is released by opening the K1 contacts. These two diodes are in parallel with the target coil and actuating contacts. CR3 is necessary to allow T5 to drop to the reference voltage level. Diode CR5 is a 30 volt zener diode which stabilizes the K1 pickup time for varying DC bus voltages.

2. Operation of Trip and Auxiliary Outputs

The reed relays K2 and K3 are operated by transistor Q1 which acts as a switch to block operation below 60 percent of rated voltage. The response time of K2 and K3 is less than 1.0 millisecond including bounce. A 5.1 volt zener diode CR7 and a factory set voltage divider R5 and R4 determine the pickup level of Q1. The voltage divider is set to pick up at 65 percent of rated bus voltage. However, to meet the timing requirements of 1.0 millisecond pickup time, the applied bus voltage must be at least 80 percent of rated value.

R6 prevents turn on of Q1 due to leakage currents and CR8 protects the base-emitter junction of Q1 from excessive reverse voltage. CR6 limits the voltage on the Q1 collector when K2 and K3 are deenergized.

The K2 and K3 reed relays trigger the output silicon controlled rectifiers (SCR's) Q12, Q22, Q32 and Q42. The output terminal T2 and T1 are connected in series with a breaker trip coil and an "a" contact which is closed when the breaker is closed. Trip current must flow into T2 and out of T1. The energy to trigger the gate of the SCR is stored in the capacitor C13 which is continuously charged through CR19 and R12. CR19 prevents rapid discharge of C13 by Q12 when it is triggered. During standby, the gate of the SCR is clamped to the cathode by a normally closed contact of K2 in order to provide high noise immunity. Q12 is triggered by closing the normally open contacts K2 which discharges C13 through R13 and R14. R10 and C12 provide rate suppression across the anode to cathode terminals of the SCR and VR1 is a metal oxide varistor (MOV) to limit transient voltages.

Four additional contacts of K2 and K3 reed relays are provided for alarm initiation or other auxiliary functions. These are connected to output terminals T3-15, T13-14, T8-17 and T16-18.

CONSTRUCTION

The case is suitable for either surface or semi-flush panel mounting and an assortment of hardware is available for either mounting. Each cover screw has provision for a sealing wire.

The case has studs or screw connections at the bottom and top for the external connections. The electrical connections between the relay unit and the case studs are made through spring-backed contact fingers mounted in stationary molded inner and outer blocks. A removable connecting plug completes the circuits. The outer block, attached to the case, has the studs for the external connections, and the inner block has the terminals for the internal connections. The contact assembly is shown in Fig. 10.

The relay mechanism is mounted in a steel framework called the cradle and is a complete unit with all leads being terminated at the inner block. This cradle is held firmly in the case with a latch at the top and the bottom and by a guide pin at the back of the case. The cases and cradles are so constructed that the relay cannot be inserted in the case upside down. The connecting plug, besides making the electrical connections between the respective blocks of the cradle and case, also locks the latch in place. The cover, which is fastened to the case by thumbscrews, holds the connecting plug in place.

To draw out the relay unit, the cover is first removed, and the plugs draw out. The latches are then released, and the relay unit can be easily drawn out. To replace the relay unit, the reverse order is followed.

A separate testing plug can be inserted in place of the connecting plug to test the relay on the panel, either from its normal source of power or from other sources. Or, the relay unit can be withdrawn for testing and replaced by a spare unit.

RECEIVING, HANDLING AND STORAGE

The relays, when not included as a part of a control panel, will be shipped in cartons designed to protect them against damage. Immediately upon receipt of a relay, examine it for any damage sustained in transit. If injury or damage resulting from rough handling is evident, file a damage claim at once with the transportation company and promptly notify the nearest General Electric Apparatus Sales Office.

Reasonable care should be exercised in unpacking the relay in order that none of the parts are injured or the adjustments disturbed.

If the relays are not to be installed immediately, they should be stored in their original cartons in a place that is free from moisture, dust, and metallic chips. Foreign matter collected on the outside of the case may find its way inside when the cover is removed and cause trouble in the operation of the relay.

ACCEPTANCE TESTS

The relay should be examined and tested upon delivery to ensure that no damage has been sustained in shipment and that the relay functions properly.

The following tests may be performed as part of the installation of the relay at the discretion of the user. Since most operating companies use different procedures for acceptance and installation tests, the following section includes all applicable tests that may be performed on the relays.

VISUAL INSPECTION

Check the nameplate stamping to ensure that the model number agrees with the relay model number which was ordered.

Remove the relay from its case and check that there are no broken or cracked molded parts or other signs of physical damage, and that all the screws are tight.

MECHANICAL INSPECTION

1. The telephone relay units used in the target operating models of these relays should be checked to have no more than two mils gap between the armature stop and the armature when it is at rest position. The moving arm should have sufficient pressure to insure that the normally closed K1 contacts stay closed for at least 15 milliseconds after the coil is energized.
2. Make sure that the fingers in the relay cradle and case blocks agree with the internal connections diagram. The internal connections diagram is included here as Figs. 5 and 6.

ELECTRICAL INSPECTION

Refer to Fig. 7 for the suggested test circuit for checking pickup time and the no-pickup level. Determine the number of auxiliary and SCR outputs and test accordingly. The test circuit shown is for the model SBA12B1A or SBA12B2A. For models without a target circuit omit the connection to terminal T7. A two channel oscilloscope with a long persistence CRT or a storage scope is the recommended means for checking the response characteristics. The test push button energizes an external relay which in turn connects the operating terminal T5 to the power supply through a one-ohm resistor. The power supply voltage should be 80 percent of the rated voltage for the particular model being tested. The oscilloscope should be set for external trigger and the vertical sensitivity of both channels should be 50 volts/division or suitably attenuated. The horizontal sweep rate should be one millisecond per division. The delay of channel B with respect to channel A should be less than 1.0 millisecond for all outputs. Input and output signals are all positive signals.

To check the low voltage no-operate feature, reduce the input voltage to 60 percent of rated voltage. The outputs should not pickup when the OPERATE button is pressed.

The target operating feature may be checked using a scope with a differential input amplifier. Refer to Fig. 8 for the circuit and the monitoring points. A positive voltage pulse of at least 7.0 volts should appear across the one-ohm resistor and should decay to no less than 3.0 volts at 15 milliseconds. The pulse should decay to zero volts after 15 milliseconds. Be sure that the relay is energized for 45 seconds before testing the target operating feature.

Another test for target operating capability is to arrange a configuration of targets representing the intended application. The target current produced by the SBA is dependent on the total external target impedance and therefore no more than three targets should be operated in series or in parallel. Never parallel a high impedance target (0.2A) with a low impedance target (2.0A) and do not wire high and low impedance targets in series.

INSTALLATION PROCEDURE

INTRODUCTION

The relay should be installed in a clean, dry location, free from dust and excessive vibration and well lighted to facilitate inspection and testing.

The relay should be mounted on a vertical surface. The outline and panel drilling dimensions are shown in Fig. 9.

The internal connection diagrams for the relays are shown in Figs. 5 and 6.

A typical external connection diagram is shown in Figs. 1 and 2.

TEST PLUGS

All General Electric drawout case relays may easily be tested in the case by using either the XLA12A or XLA13A test plugs. The XLA12A has 20 fingers which bring both the ten relay connections and the ten external connections to the front of the relay for ease access. The XLA13A test plug brings only the ten relay connections to the front of the relay.

For further information on these test plugs refer to Section 7332 in the General Electric Apparatus Handbook or contact the nearest General Electric Apparatus Sales Office.

PERIODIC CHECKS AND ROUTINE MAINTENANCE

CAUTION

Remove ALL power from the relay before removing or inserting any of the printed-circuit boards. Failure to observe this caution may result in damage to and/or misoperation of the relay.

In view of the vital role of protective relays in the operation of a power system it is important that a periodic test program be followed. It is recognized that the interval between periodic checks will vary depending upon environment, type of relay and the user's experience with periodic testing. Until the user has accumulated enough experience to select the test interval best suited to his individual requirements it is suggested that the points listed under ACCEPTANCE TESTS be checked at an interval of from one to two years.

CONTACT CLEANING

For cleaning relay contacts, a flexible burnishing tool should be used. This consists of a flexible strip of metal with an etched-roughened surface, resembling in effect a superfine file. The polishing action is so delicate that no scratches are left, yet it will clean off any corrosion thoroughly and rapidly. Its flexibility insures the cleaning of the actual points of contact. Do not use knives, files, abrasive paper or cloth of any kind to clean relay contacts.

RENEWAL PARTS

It is recommended that sufficient quantities of renewal parts be carried in stock to enable the prompt replacement of any that are worn, broken, or damaged.

When ordering renewal parts address the nearest Sales Office of the General Electric Company, specify quantity required, name of the part wanted, and the complete model number of the relay for which the part is required.

* Indicates revision

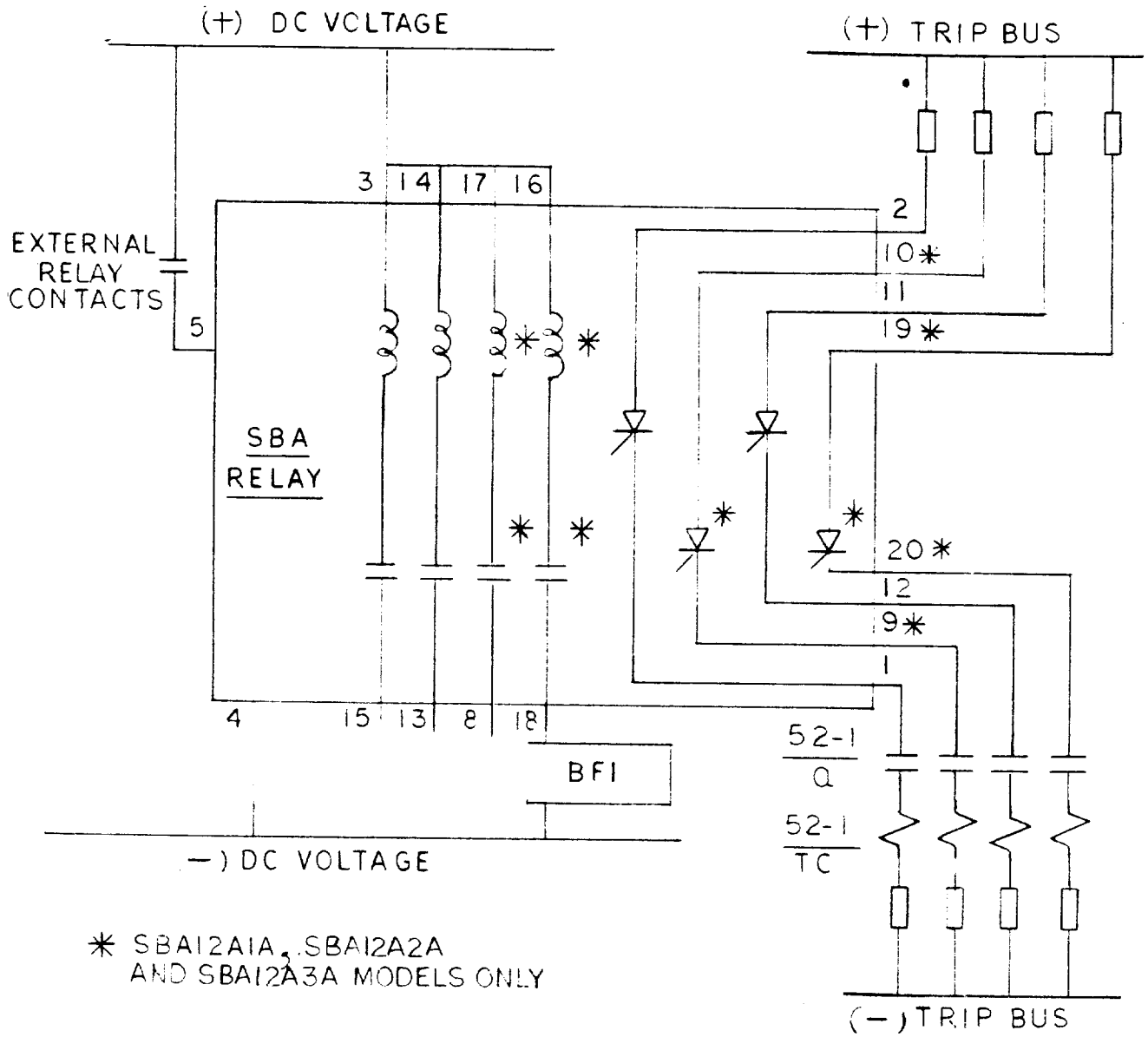

* FIG. 1 (0269A3066 [1]) EXTERNAL CONNECTIONS DIAGRAM FOR SBA 11A1A, 11A2A, 12A1A, 12A2A, 12A3A. NO TARGET OPERATION.

* Indicates revision

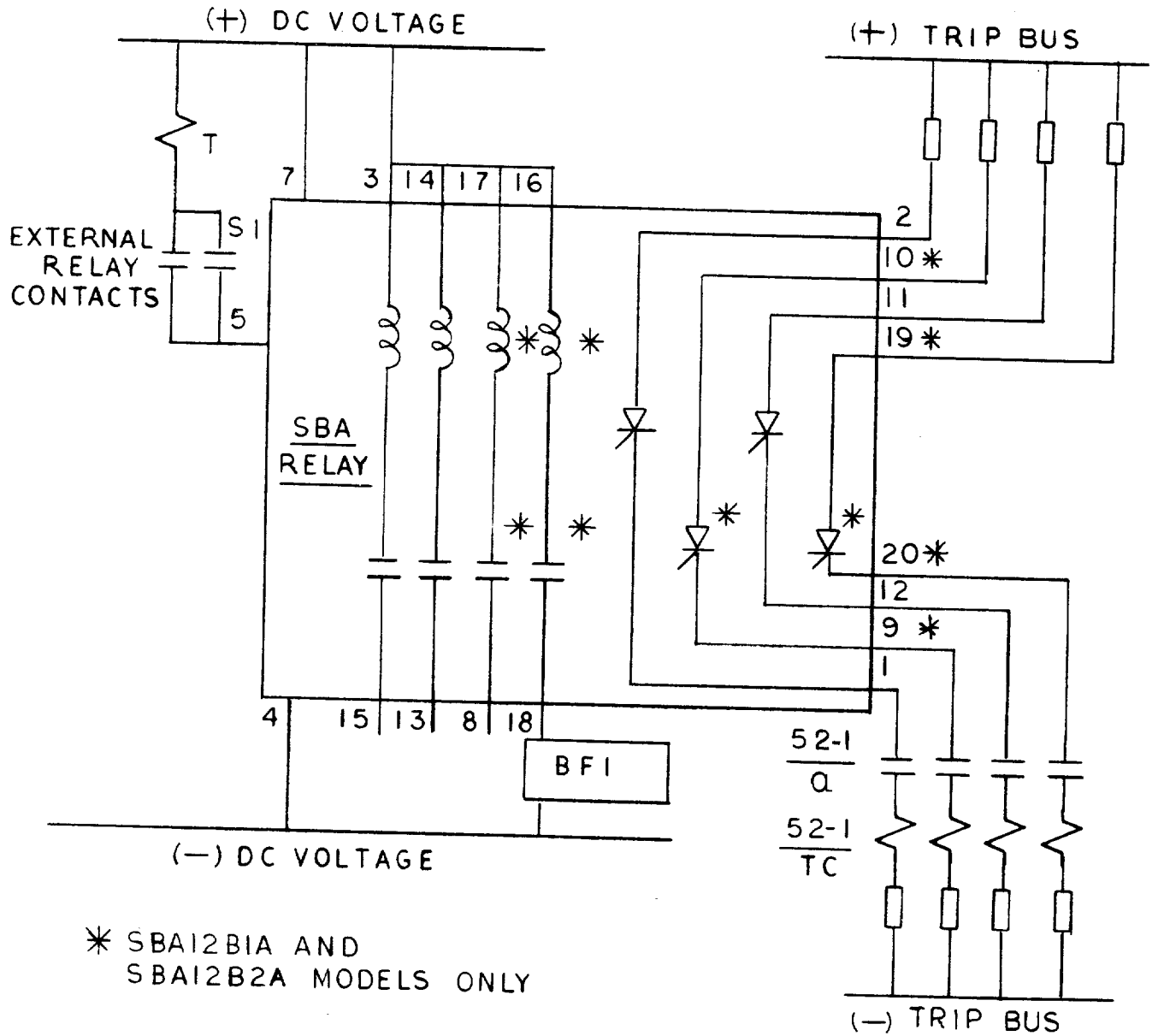

FIG. 2 (0269A3067-0) EXTERNAL CONNECTIONS DIAGRAM FOR SBA 11B1A, 11B2A, 12B1A, 12B2A

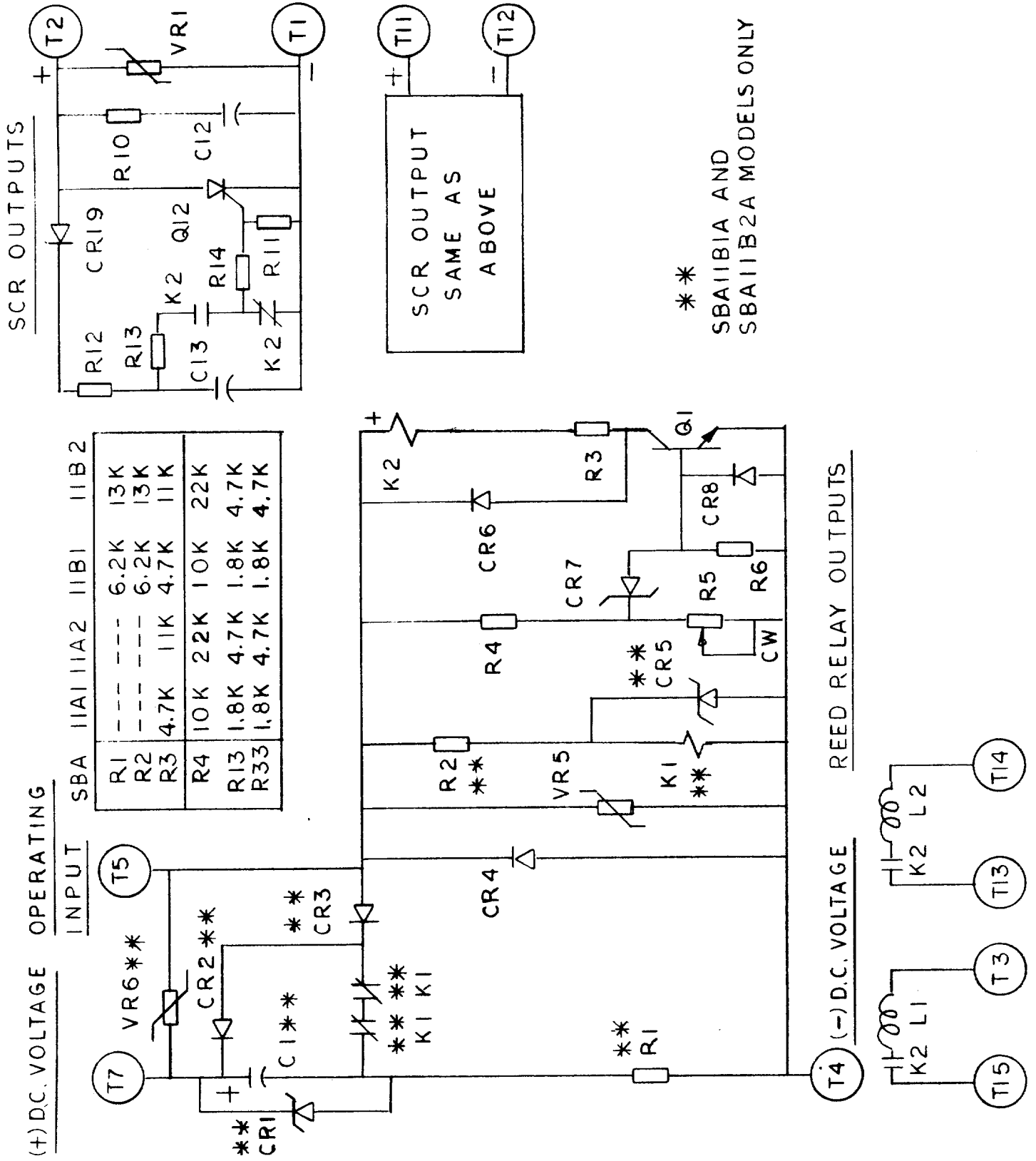

FIG. 3 (0269A3068-0) CIRCUIT DIAGRAM FOR SBA 11A1A, 11A2A, 11B1A, 11B2A. TWO OUTPUT MODELS

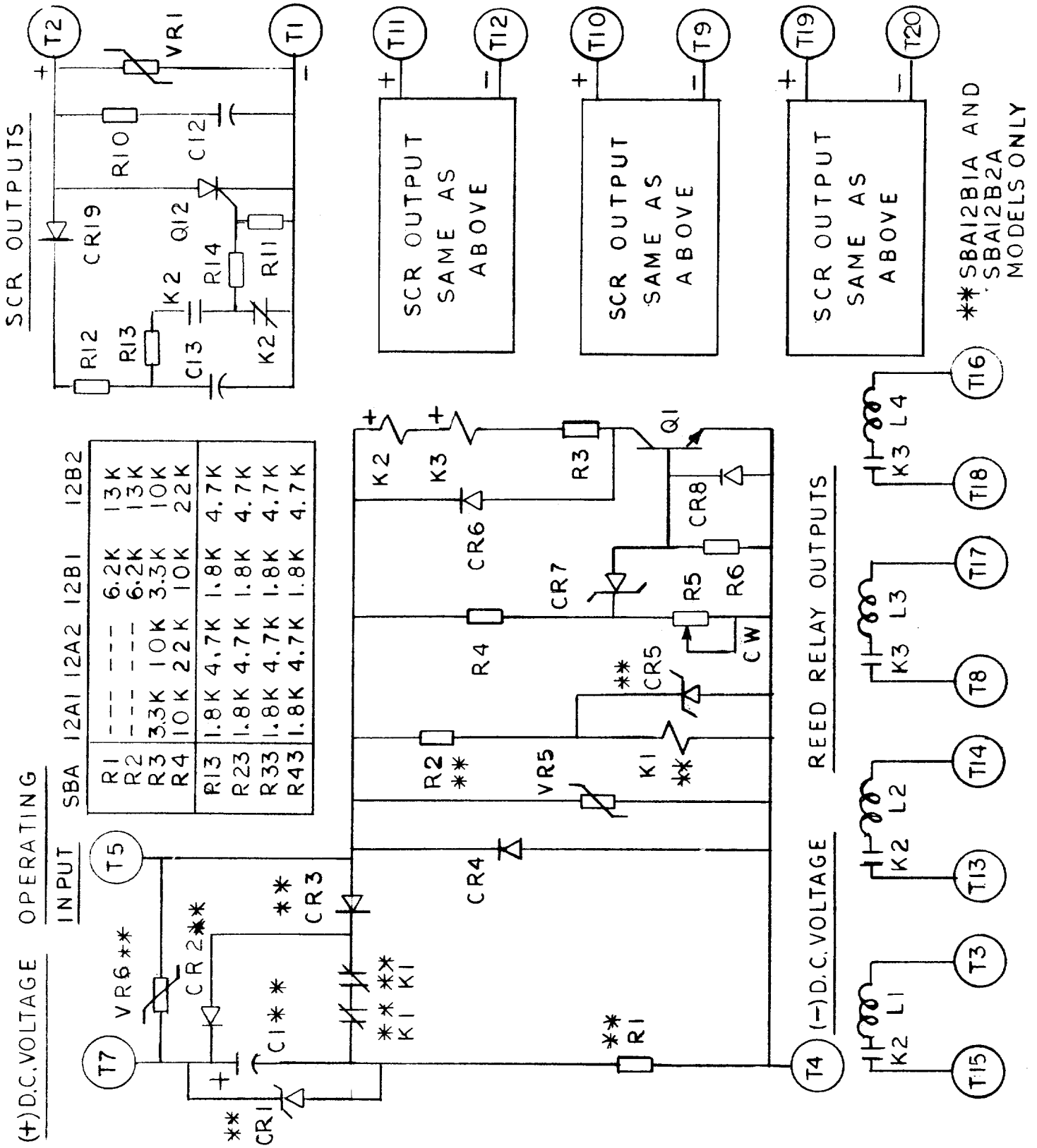

FIG. 4 (0269A3069-0) CIRCUIT DIAGRAM FOR SBA 12A1A, 12A2A, 12B1A, 12B2A. FOUR OUTPUT MODELS

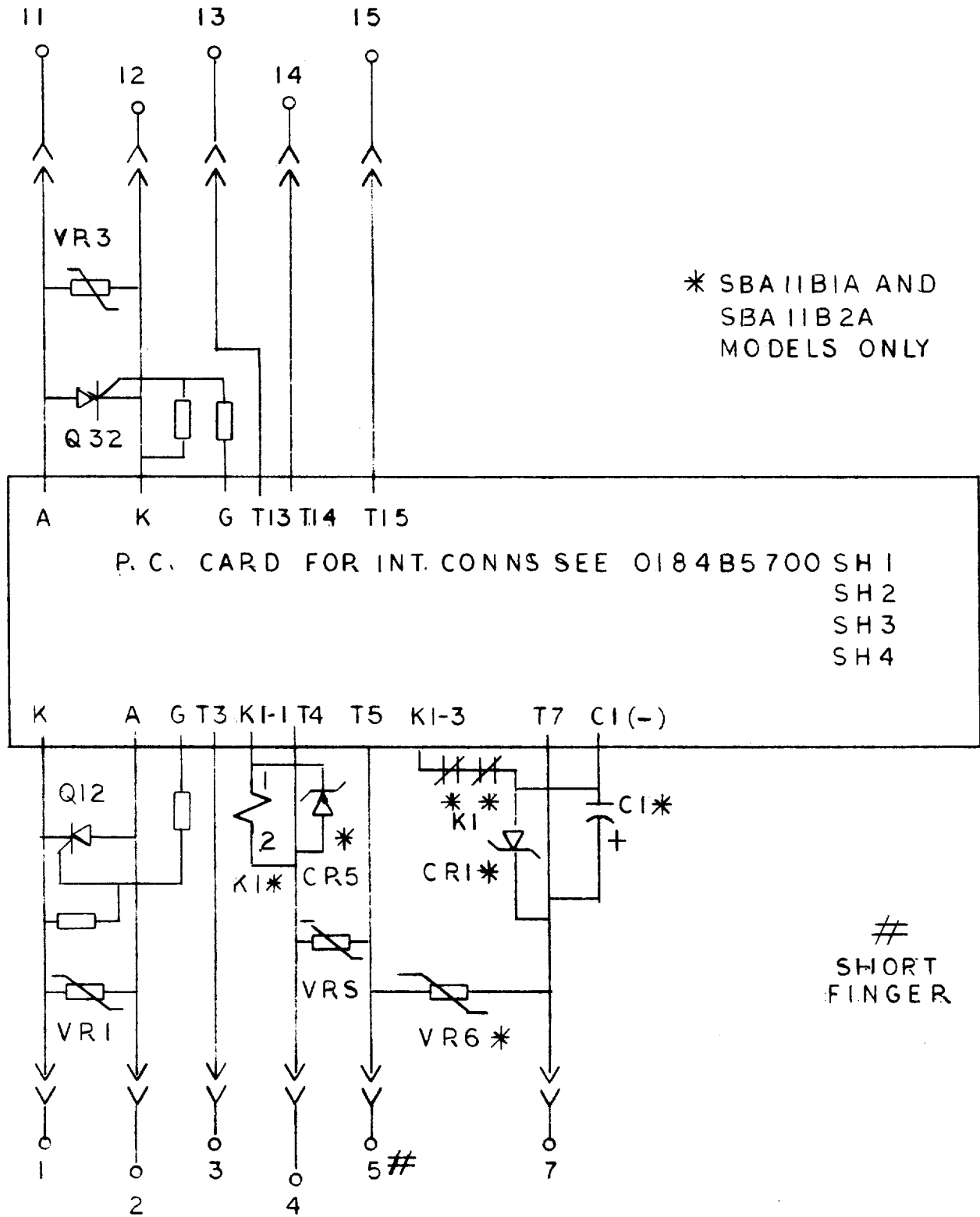
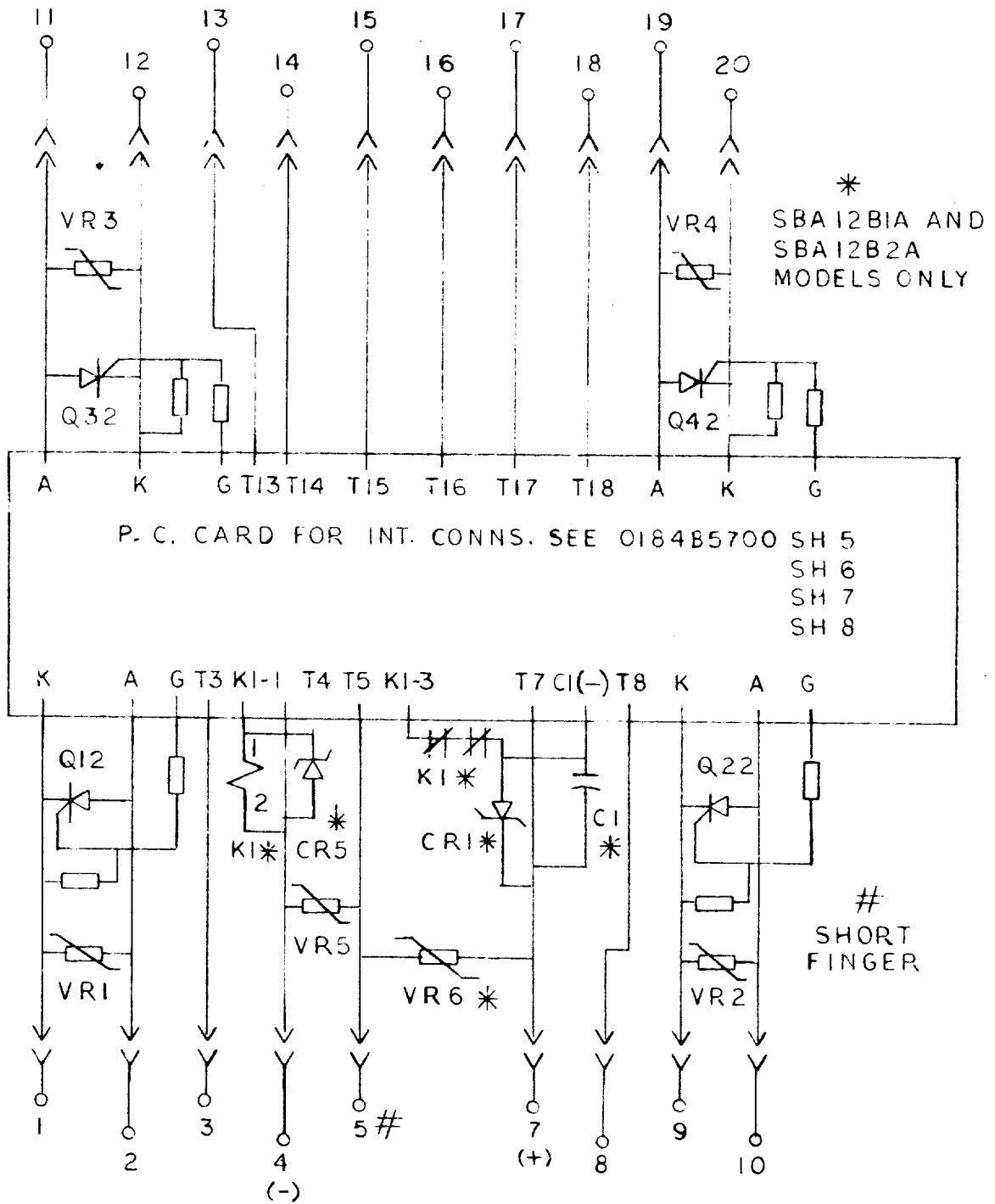
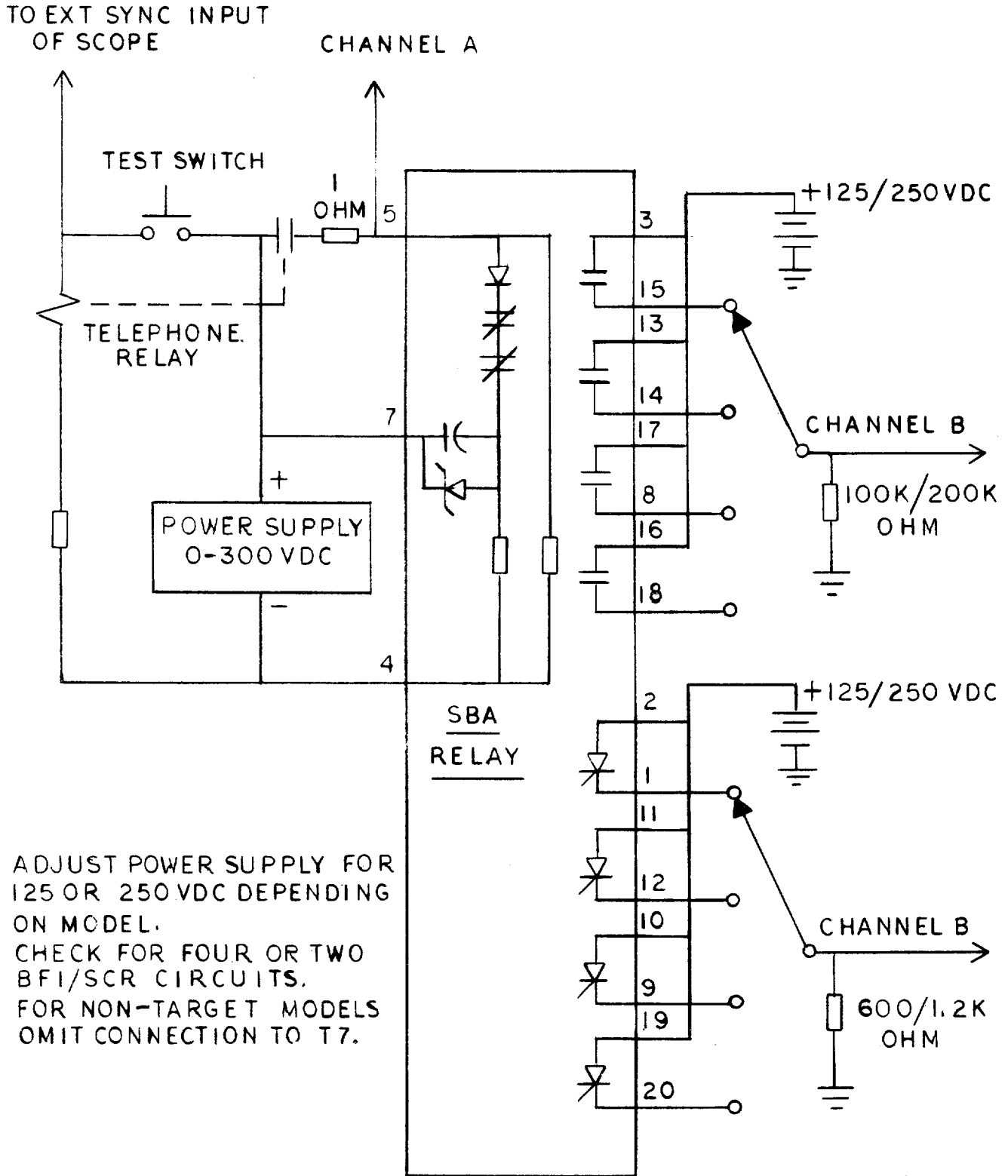

FIG. 5 (Q269A3070-0) INTERNAL CONNECTIONS FOR SBA 11A1A, 11A2A, 11B1A, 11B2A. TWO OUTPUTS MODELS



* FIG. 6 (0269A3071 [1]) INTERNAL CONNECTIONS FOR SBA 12A1A, 12A2A, 12B1A, 12B2A. FOUR OUTPUT MODELS

* Indicates revision



ADJUST POWER SUPPLY FOR 125 OR 250 VDC DEPENDING ON MODEL.
 CHECK FOR FOUR OR TWO BFI/SCR CIRCUITS.
 FOR NON-TARGET MODELS OMIT CONNECTION TO T7.

FIG. 7 (0269A3072-0) PICKUP TIME TEST AND PICKUP LEVEL TEST

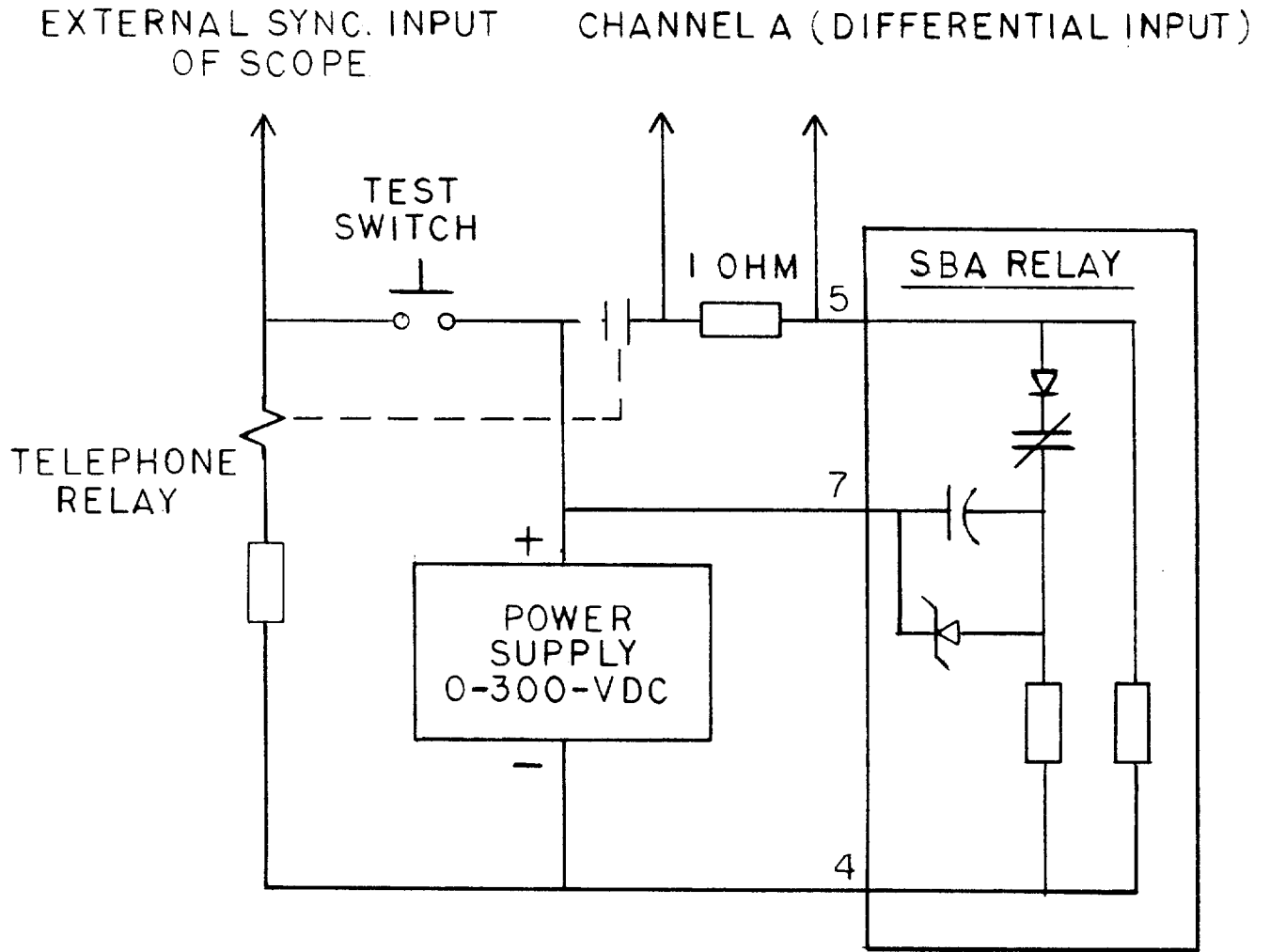
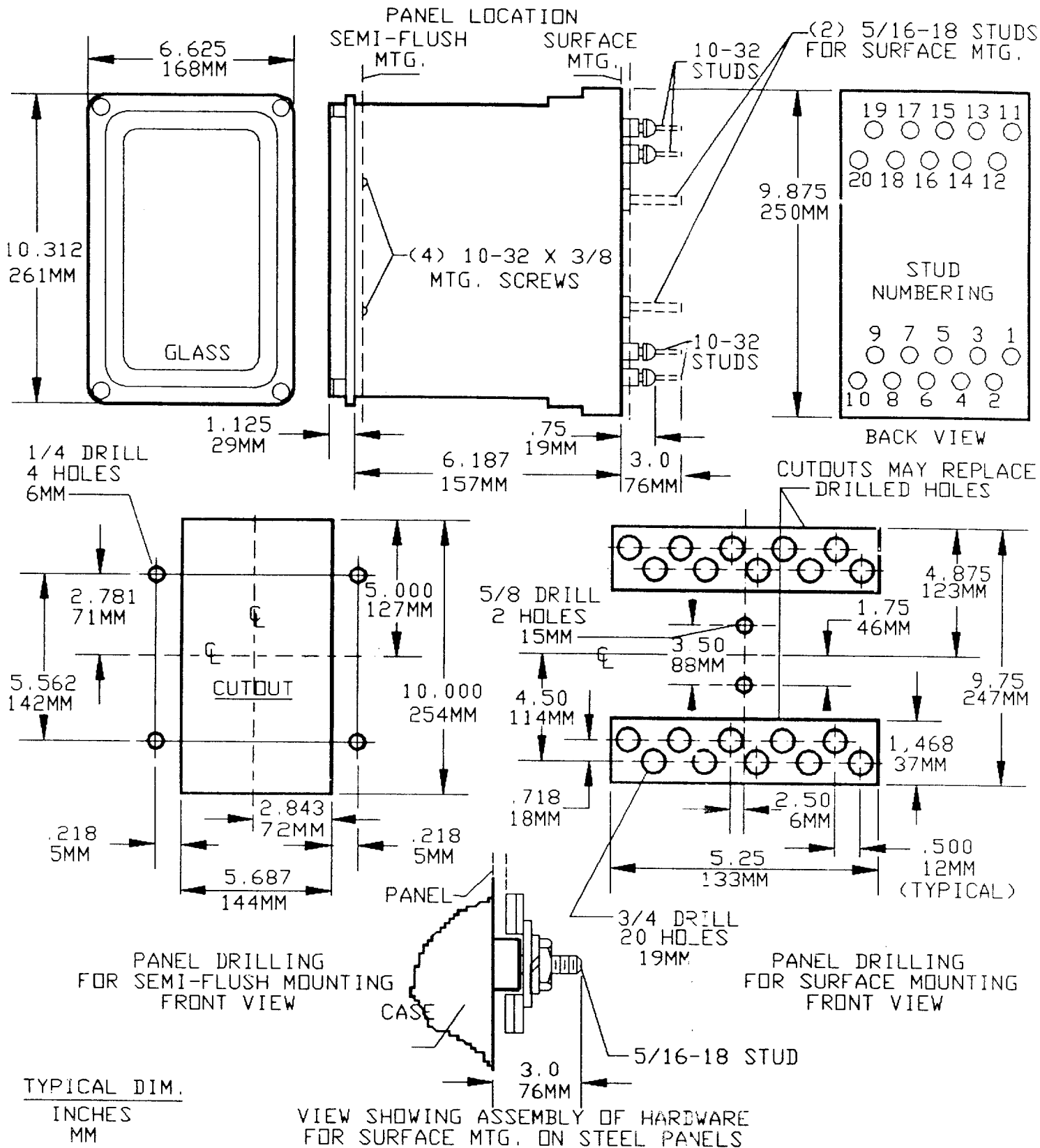
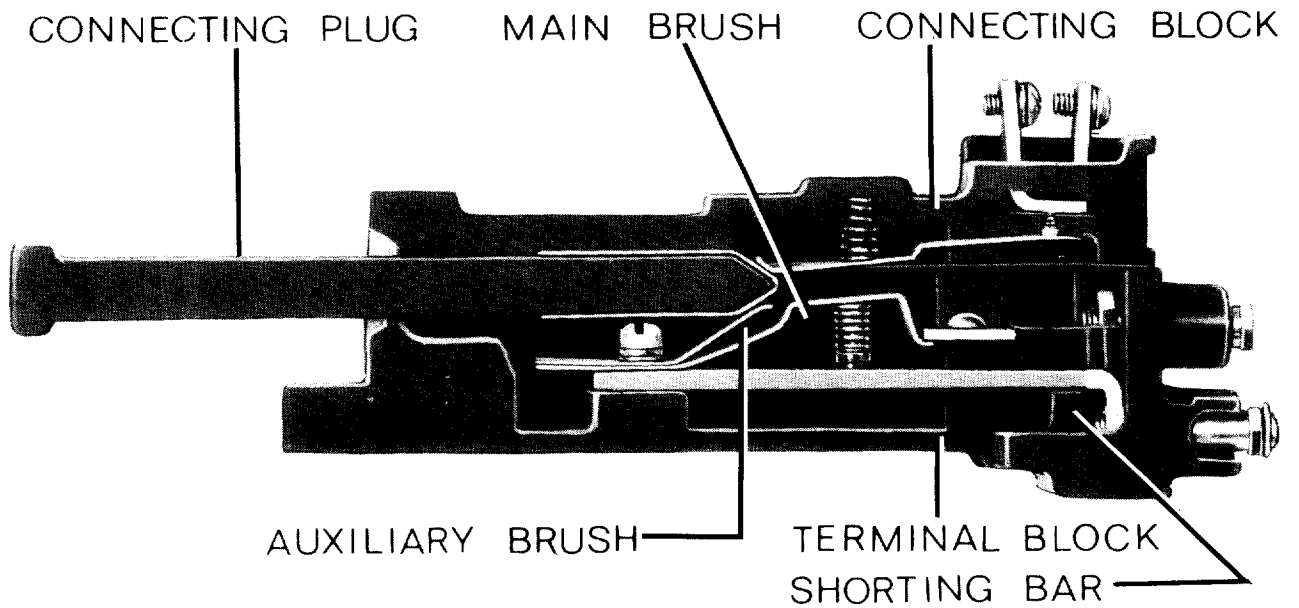

FIG. 8 (0269A3073-0) TARGET OPERATING TEST



* FIG. 9 (K-6209272 [7]) OUTLINE AND PANEL DRILLING FOR DRAWOUT RELAYS - SIZE S2



NOTE: AFTER ENGAGING AUXILIARY BRUSH, CONNECTING PLUG TRAVELS $\frac{1}{4}$ INCH BEFORE ENGAGING THE MAIN BRUSH ON THE TERMINAL BLOCK

FIG. 10 (8025039) DRAWOUT CASE - CONTACT ASSEMBLY CUTAWAY



GE Power Management

**215 Anderson Avenue
Markham, Ontario
Canada L6E 1B3
Tel: (905) 294-6222
Fax: (905) 201-2098
www.ge.com/indsys/pm**