



**INSTRUCTIONS**

GEK-65586

---

**STATIC INSTANTANEOUS OVERCURRENT RELAY  
TYPE SBC31A**

---

**GENERAL  ELECTRIC**

CONTENTS

	<u>PAGE</u>
<b>INTRODUCTION</b> .....	3
<b>DESCRIPTION</b> .....	3
<b>APPLICATION</b> .....	4
<b>OPERATION</b> .....	4
GENERAL .....	4
RANGES .....	4
TABLE I - PICKUP CURRENT RANGE .....	4
<b>RATINGS</b> .....	5
TABLE II - BFT CONTACT RATINGS .....	5
TABLE III - TARGET RATINGS .....	5
SURGE WITHSTAND CAPABILITY .....	6
<b>BURDENS</b> .....	6
TABLE IV - 5 AMPS, 60 HERTZ BURDEN .....	7
TABLE V - 10 AMPS, 60 HERTZ BURDEN .....	7
TABLE VI - BATTERY DRAIN .....	8
<b>CHARACTERISTICS</b> .....	8
POWER SUPPLY .....	8
LEVEL DETECTOR .....	8
<b>SETTINGS</b> .....	9
<b>OPERATING PRINCIPLES</b> .....	9
INTRODUCTION .....	9
PRINTED CIRCUIT CARDS .....	10
"A" CARD (LEVEL DETECTOR WITH ADJUSTABLE "FILL-IN" .....	10
"C" CARD (RELAY DRIVER CARD) .....	11
"X" CARD (THREE FULL WAVE BRIDGES) .....	11
"Y" CARD (ZENER REGULATED POWER SUPPLY) .....	11
CURRENT DETECTORS .....	12
GENERAL DESCRIPTION .....	12
<b>ACCEPTANCE TESTS</b> .....	13
FILL-IN TIMER SETTING .....	13
CURRENT DETECTOR PICKUP TEST .....	14
CURRENT DETECTOR PICKUP VERNIER SETTINGS .....	14
<b>INSTALLATION PROCEDURE</b> .....	15
INTRODUCTION .....	15
CURRENT DETECTOR PICKUP SETTING .....	16
<b>PERIODIC CHECKS AND ROUTINE MAINTENANCE</b> .....	16
CONTACT CLEANING .....	16
<b>SERVICING</b> .....	17
<b>RECEIVING, HANDLING AND STORAGE</b> .....	17
<b>RENEWAL PARTS</b> .....	17
<b>LIST OF ILLUSTRATIONS</b> .....	19

## STATIC INSTANTANEOUS OVERCURRENT RELAY

### TYPE SBC31A

#### INTRODUCTION

The Type SBC31 relay is a three phase static fault instantaneous overcurrent relay. This relay provides high speed operation at low multiples of pickup, minimum transient overreach and fast drop-out times.

#### DESCRIPTION

The SBC31 relays covered by these instructions are packaged in the M2D drawout case, the outline and mounting dimensions for which are shown in Fig. 18. The relays include the following basic components and features.

1. A fast reset current level detector with two independently adjustable pickup settings for phase ( $I_A$  or  $I_B$ ) and phase/ground ( $I_C/3I_0$ ) currents.
2. Four electrically separate (BFT) contact output circuits. One of these circuits has an electromechanical series target (T2).
3. One electrically separate (BFT) output circuit with selectable normally open or normally closed contact.
4. One output circuit common to the positive DC input and with an electromechanical series target (T1)
5. A regulated power supply with undervoltage cutoff.
6. Surge suppression on all AC and DC input circuits.

The power supply in these relays is so designed that the DC voltage must exceed 60 percent of the nominal voltage rating in order for the relay to operate. This feature prevents false trips from capacitance discharge or from the voltage divider effect of the ground fault lamps on the DC bus in the event that the DC input terminal of the SBC is accidentally grounded.

*These instructions do not purport to cover all details or variations in equipment nor to provide for every possible contingency to be met in connection with installation, operation or maintenance. Should further information be desired or should particular problems arise which are not covered sufficiently for the purchaser's purposes, the matter should be referred to the General Electric Company.*

*To the extent required the products described herein meet applicable ANSI, IEEE and NEMA standards; but no such assurance is given with respect to local codes and ordinances because they vary greatly.*

## APPLICATION

The SBC31 relay is intended for applications requiring an instantaneous AC overcurrent detector with fast pickup, fast reset, minimum overreach, or continuous operation in the picked up position. The three input current circuits to the SBC31 can be connected to the three phase currents ( $I_A$ ,  $I_B$ ,  $I_C$ ) in a three-phase system, or to two phases and the residual current ( $I_A$ ,  $I_B$ ,  $3I_0$ ).

Typical applications for the SBC31 relay include local back-up protection for circuit breaker failure, underrated interrupter applications on circuit breakers or circuit switches, or fault detector supervision on distance schemes. The external connections for the SBC31 are shown in Fig. 3.

Fig. 4 shows an application where an instantaneous overcurrent relay may be used to prevent attempted interruptions of fault currents above breaker rating. For some system conditions, heavy close-in line faults such as F1 might exceed the interrupting rating of the line breaker (3). The application of an instantaneous overcurrent relay set near the line breaker rating permits operation of the bus tie breaker (BT) to relieve the duty on the line breaker for these critical faults before operation by the line breaker. The SBC31 is particularly well suited to this type of application since it has less than ten percent transient overreach and operating times of approximately one-half cycle (60 hertz basis) at 1.5X pick up. (Refer to Fig. 7 for operating time curves). It is usually possible to coordinate this high set overcurrent protection right up to the interruption limits of the line breaker without introducing any delay in the line relaying which would affect other less critical faults such as F2.

Fig. 5 shows a similar application for protection of a circuit switcher at a transformer tap on a transmission line. The SBC31 overcurrent relay can be set to operate just below the interrupting capacity of the circuit switcher to avoid possible interrupter failure for faults at the high side of the transformer at F1. The SBC would be connected to block the operation of the circuit switcher until the fault is cleared at line terminals A and B.

Applications of the SBC31 as a breaker failure relay would be accomplished on a per-breaker basis. On this basis the current inputs to a particular SBC relay come from the current transformers that measure the current in the associated breaker. The SBC DC supply is enabled by the protective relays associated with the zone of protection, and the output of the SBC is connected to a definite time timer, such as a Type SAM timing relay. The timer is set for sufficient delay to permit normal interruption of the associated breaker when operated by the primary relays. If the breaker fails to interrupt successfully within this time, the timer will time out and initiate tripping of all breakers necessary to clear the fault. The timing sequence for a normal interruption and a breaker failure condition are shown in Fig. 8. The SBC31 pickup time for this type of application is shown in Fig. 9. A detailed discussion of breaker failure applications for various bus configurations is included in GEK-45464.

The SBC31 is also well suited to applications such as pilot and distance relay line protection schemes requiring high speed overcurrent detectors.

**OPERATION**

GENERAL

There are three current inputs to the SBC31 relays. They are either three-phase currents ( $I_A$ ,  $I_B$ ,  $I_C$ ) or two-phase ( $I_A$ ,  $I_B$ ) and one ground current ( $3I_0$ ). Each current input is converted to a voltage by a transactor which is tapped on its primary side to provide pickup multiples of 1X, 2X or 4X the minimum current rating of the relay.

WARNING: DO NOT CHANGE TAP SETTINGS WHILE RELAY IS ENERGIZED. CHANGING TAPS CAUSES THE CURRENT TRANSFORMER FEEDING THE SBC TO BE OPEN CIRCUITED AND TO GENERATE DANGEROUS VOLTAGES AT THE TAP TERMINALS.

The secondaries of each transactor are connected to a full wave bridge rectifier and a resistive load with an adjustable voltage divider output for a vernier setting adjustment of the pickup level. The vernier range is 1.0 to 2.5. A voltage regulator diode limits the voltage during high multiples of input current in excess of the pickup level.

The level detector (A card) produces an output if the input current is above the level detector setting. The level detector output immediately energizes the instantaneous trip circuit (C card) and causes the BFT1 and BFT2 relays to operate.

RANGES

Phase ( $I_A$ ,  $I_B$ ,  $I_C$ ) or Phase/Ground ( $I_A$ ,  $I_B$ ,  $3I_0$ ) Currents

Pickup current is continuously adjustable from 1 to 10 or 8 to 80 amperes by means of tap adjustments and a vernier rheostat (P1 or P2) on the front panel.

TABLE I  
PICKUP CURRENT RANGE

MINIMUM CURRENT (MODEL TYPE)	TAP MULTIPLIER OF MINIMUM CURRENT		
	1X	2X	4X
1 amp	1 to 2.5	2.0 to 5.0	4.0 to 10
8 amp	8 to 12	16 to 40	32 to 80

**RATINGS**

The SBC current circuits are rated at ten amps continuously, and have one-second thermal ratings of 210 amps.

CAUTION: WHEN HIPOTTING THE SBC, REMOVE ALL EXTERNAL WIRING FROM TERMINAL 11. DO NOT HIPOT TERMINAL 11. THE REASON IS THAT CAPACITORS C1-C8 ARE RATED FOR 600 VDC AND THE HIPOT VOLTAGE MAY DAMAGE THE CAPACITORS.

The output telephone relays, BFT, are continuously rated at nameplate rated DC supply voltage. Table II lists the ratings of the six electrically separate BFT contacts.

TABLE II

BFT CONTACT RATINGS

RATING	CONTINUOUS CURRENT AMPS	TRIP DUTY AMPS	INTERRUPTION CURRENT (AMPS) INDUCTIVE**	NON-INDUCTIVE
125 V DC	3	30	0.50	1.5
250 V DC	3	30	0.25	1.0
115 V 60 HZ	3	30	0.75	2.0
230 V 60 HZ	3	30	0.50	1.5

\*\* The inductive rating is based on the inductance of an average trip coil.

Table III lists the ratings of the electromechanical targets (T1 and T2) on both the 0.2 and 2.0 amp taps that are available.

TABLE III

TARGET RATINGS

TAP SETTING	OPERATING RANGE (AMPS)	TRIP DUTY (AMPS)	DC RESISTANCE (OHMS)
2.0	2 - 30	30	0.13
0.2	0.2 - 3	3	7.0

SURGE WITHSTAND CAPABILITY

The SBC relay will withstand the following test voltage waveform without incorrect operation or damage to any component.

The test voltage waveform consists of a high frequency damped oscillation with a frequency of 1.5 megahertz. The source has an internal impedance of 150 ohms. The initial value (zero-to-peak) is 2500 volts and the damping is such that the envelope of the waveform decays to half the initial value (1250 volts) in 6.0 microseconds. The test voltage is applied between relay surge ground and each of the other relay terminals.

**BURDENS**

The AC burden for each of the current transformer circuits is tabulated in Table V for five amperes of 60 hertz current through each basic current setting range, minimum and maximum respectively.

TABLE IV  
5 AMP, 60 HERTZ BURDEN

BASIC RANGE	PICKUP SETTING (AMPS)	VOLT-AMPS (I=5 AMPS)	IMPEDANCE (OHMS)	POWER-FACTOR (LAGGING DEGREES)
(1-2A)	1	0.53	0.021	21
(1-2A)	2.0	0.53	0.021	23
(2-4A)	2.0	0.35	0.014	15
(2-4A)	4.0	0.35	0.014	18
(4-10A)	4.0	0.28	0.011	19
(4-10A)	10.0	0.28	0.011	20

The AC burden for each of the current transformer circuits is tabulated in Table V for ten amperes of 60 hertz current through each basic current setting range, minimum and maximum respectively.

TABLE V  
10 AMP, 60 HERTZ BURDEN

BASIC RANGE	PICKUP SETTING (AMPS)	VOLT-AMPS (I=10 AMPS)	IMPEDANCE (OHMS)	POWER-FACTOR (LAGGING DEGREES)
(8-16A)	8	0.90	0.009	14
(8-16A)	16	0.89	0.009	14
(16-32A)	16	0.71	0.007	6
(16-32A)	32	0.70	0.007	6
(32-80A)	32	0.62	0.006	3
(32-80A)	80	0.61	0.006	3

The overall battery drain at relay terminals 9 and 10 is itemized in Table VI for the three possible relay DC ratings under two possible operating conditions.

TABLE VI  
BATTERY DRAIN

RATED DC (VOLTS)	STEADY-STATE CONDITION	NOMINAL DC DRAIN (MILLIAMPS)
48	DROPPED OUT TRIPPING	128 232
125	DROPPED OUT TRIPPING	121 246
250	DROPPED OUT TRIPPING	132 239

CHARACTERISTICS

POWER SUPPLY

All the SBC relays covered by this book contain a regulated power supply. This power supply regulates the voltage to the measuring and output functions so that they perform properly over a range of applied DC voltage from 80 percent to 110 percent of rated voltage.

The power supply card also prevents operation for grounding of relay terminal 9. The power supply card must see greater than 60 percent of battery voltage before the power supply will be switched on.

LEVEL DETECTOR

The level detector in the SBC31 relay is comprised of magnetic input circuits for each current, two pickup setting potentiometers, one level sensing circuit, and a fill-in timer. The level sensing circuit produces an output when the instantaneous magnitude of the input exceeds its fixed pickup sensitivity. The output will go away as soon as the instantaneous magnitude of the input gets below its fixed drop-out level which is greater than 95 percent of the pickup level. The fill-in timer will produce an output as soon as a signal appears at its input. This output will persist until the input from the level sensing circuit goes away and the fill-in time expires.

As will be noted from Fig. 3, the input to the level sensing circuit is provided from three transactor circuits. The voltage output from each transactor is proportional to the respective current inputs. The level detector sees the highest of the three input signals and ignores the rest. The phase A and phase B signals are combined and attenuated by a potentiometer (P1). The phase C or  $3I_0$  signal is attenuated by another potentiometer (P2) before being combined with the phase A and phase B signals. When phase C is being monitored, the P1 and P2 potentiometer will be set for the same pickup level. Since the sensitivity of the level sensing circuit is fixed by design,



the pickup settings for phase and ground currents are made independently by means of the two potentiometers in conjunction with the current tap selection.

The normal factory setting on the fill-in timer is set for approximately two milliseconds. With this setting the drop-out time of the relay is about ten milliseconds. The range of pickup adjustment will be as given under the section on RATINGS.

### SETTINGS

The following settings should be made in the order in which they are listed below:

1. Current detector fill-in timer setting on "A" card
2. Phase A and B current pickup setting (tap multiplier and P1 adjustment)
3. Phase C or ground current pickup setting (tap multiplier and P2 adjustment)
4. Select normally open or normally closed contact configuration of terminals 19 and 20.

### OPERATING PRINCIPLES

#### INTRODUCTION

The SBC31 contains functional elements as described below.

- A) Plus 10.2V, minus 10.2V DC zener regulated power supply with RF surge suppression.  
(Printed circuit card identified as "Y")
- B) Power supply level sensing circuit to prevent pickup if terminal 9 is grounded.
- C) AC circuit surge suppression:  
(C1 through C8).
- D) Three (3) range primary tapped transactors and tap blocks for phase A, phase B or phase C/ $3I_0$  current circuits:  
(TRB, TRC, TRA ---- TBA1, TBB, TBA2, respectively)
- E) Three full wave bridges for full wave rectification of  $\emptyset A$ ,  $\emptyset B$  and  $\emptyset C/3I_0$  transactor outputs:  
(Printed circuit card identified as "X")

- F) Relay mounted components necessary for vernier transactor voltage control and overvoltage protection:  
(R1, R3, P1: R2, R4, P2; Z1; Z2; D1, D2)
- G) Level detector circuitry necessary to detect AC level and convert "FILL-IN" to DC logic levels:  
(Printed circuit card identified as "A")
- H) A relay driver card for driving the telephone type J relays and providing isolation:  
(Printed circuit card identified as "C")
- I) Two fault detector relays (BFT1 and BFT2) which are type J telephone relays with surge suppression and current limit having six (6) normally open contacts and two (2) electromechanical targets (T1, T2).

PRINTED CIRCUIT CARDS

The following sections describe the operation of the printed circuit cards.

"A" CARD (LEVEL DETECTOR WITH ADJUSTABLE "FILL-IN") - Fig. 11

The power supply voltages are connected to the following pins:

Plus 10.2 VDC	Pin #10	(Red test point)
Reference	Pins #1 and #20	(Black test point)
Minus 10.2 VDC	Pin #11	

For the "A" card, the input information is supplied to pin #2. The output information (logic level) is obtained at the respective card pins #12, #14, #16, #18 and #19.

The MC1709L operational amplifier's inverting input (4) is biased at approximately plus 2.4 volts DC by R1 and R24. While the input at TP2 is below this level, TP3 has a negative voltage level present. As the TP2 (non-inverting input) signal becomes more positive than the 2.4 VDC, the Op-Amp swings positive (TP3) and drives Q1 on.

In a quiescent dropped-out state then, TP3 is a negative signal; Q1 is off, Q2 is off, the unijunction oscillator P2, C3 and Q3 is oscillating; Q5 is off; Q6 is on and the signal at TP4 is "0." When TP3 comes high, Q1 goes on, the unijunction oscillator stops oscillating and the capacitor C3 is fully discharged, Q2 comes on, Q4 stays non-conducting, Q5 comes on, Q6 goes off, and the output at TP4 goes high.

Now as the TP3 signal goes negative again, Q1 goes off, Q2 remains conducting by virtue of the previously conducting Q5 and feed back loop CR3, CR4 and R14. The C3 capacitor begins to charge with the  $(R10 + P1) \times C3$  time constant, and the output signal remains ON.

When the C3 capacitor voltage reaches the firing level of the unijunction, a pulse is generated thus turning on the SCR Q4, which turns off Q5, resets the feed back circuit, drives Q6 on and yields a "0" output voltage. In effect, the circuitry after the Op-Amp provides the adjustable "Fill-In" time (time-delay dropout) described elsewhere in this text.

In practice, the RC time constant is factory set such that the time delay on the card (P1 adjustment) is approximately two milliseconds.

"C" CARD (RELAY DRIVER CARD) - Fig. 12

The relay driver card provides the interface circuit between the "A" card and the output telephone relays. The input is on pin #2 and the isolated output is across pins #12 and #13. With a zero input signal at TP1 input, Q1 and Q2 are off and the RL1 reed relay is de-energized. When the "A" card output goes toward plus ten VDC, it turns on Q1, Q2 and energizes the RL1 relay coil. D3 and R5 provide surge suppression for the telephone relay coils BFT1 and BFT2.

"X" CARD (THREE FULL WAVE BRIDGES) - Fig. 13

This card functions as a full wave bridge for the three transactor secondary circuits.

The inputs and outputs are noted below:

<u>PHASE</u>	<u>INPUT</u>	<u>OUTPUT</u>
$I_A$	Pins #3 & #4	Pin #9
$I_B$	Pins #5 & #6	Pin #9
$I_C/3I_0$	Pins #15 & #16	Pin #10

Reference is Pin #11

Note that the two phase outputs of  $I_A$  and  $I_B$  are connected in parallel on the "X" card so that only the highest output signal appears at pin #9. The  $I_C/3I_0$  output (pin # 10) is separate so its magnitude can be set independently of the  $I_A$ ,  $I_B$  output before entering the level detector. The output signals on pins #9 and #10 are independently attenuated and then combined in a two diode rectifier circuit which allows the most positive signal to be the input to the level detector.

"Y" CARD (ZENER REGULATED POWER SUPPLY) - Fig. 14

This card functions as a single rated zener regulated plus 10.2 volt DC, minus 10.2 volt DC power supply. The ohmic value of R6 (external to card) changes to provide single battery voltage ratings of 48V, 125V, 250V DC.

Note that for input connections, positive (+) rated DC and negative (-) DC, are connected to pins #10 and #6 respectively. Exercise caution if testing while relay is energized.

R6 is the dropping resistor that changes ohmic value as the DC rating changes.

The circuitry associated with Q1 and Q2 support the level sense switching function. Q1 is the input to the switch Q2. Q1 serves as the level detector. R1, R2 are voltage dividers across full battery voltage. ZD1 is a 6.2 volt zener diode whose temperature characteristic is compensated by the base emitter junction on Q1. This ensures temperature stability.

When the voltage at the base of Q1 exceeds 6.8 volts, Q1 turns on and pulls down the base of Q2. This allows current to flow through Q2 and charge C2 to the zener regulated 20.4 volts at pin #3.

Zener diodes ZD4 and ZD5 are the plus 10.2 volt regulators and ZD5 and ZD7 are the minus 10.2 volt regulators. The cathode of ZD4 supplies plus 10.2 volts to the relay circuits. The anode of ZD5, common with the cathode of ZD6 provides relay circuit reference. The anode of ZD7 supplies minus 10.2 volts to the relay circuits. Capacitor C2 is the regulated DC ripple filter.

CURRENT DETECTORS

General Description

The two phase elements ( $I_A$ ,  $I_B$ ) and the phase/residual element ( $I_C/3I_0$ ) are independently adjustable from the front of the relay in continuous increments as follows:

<u>Low Range Unit</u>	<u>High Range Unit</u>
1-2A	8-16A
2-4A	16-32A
4-10A	32-80A

Note that these pickup calibration marks apply to the factory convention of setting the current detector with 2.0 millisecond "fill-in" time.

The following two examples demonstrate the current detector setting calculation using the calibration marks. The assumption is, of course, that the current detector has an undisturbed factory calibration.

1. The  $I_A$  tap block screw is in the middle position (2X multiplier). The phase rheostat vernier knob is pointing at the fourth mark from the left (1.6X). Assume the relay has a minimum pickup current of one ampere. Multiplying the minimum pickup current by the tap multiplier and the pickup vernier level yields: Pickup = 1 X 2 X 1.6 = 3.2A

Approximately 3.2A RMS through the  $I_A$  current circuit is the level of current necessary to pick up the current detector. Similarly, the above applies for  $I_B$  or  $I_C/3I_0$  current.

2. The phase C/residual ( $I_C/3I_0$ ) tap block screw is in the right position (4X multiplier). The ( $I_C/3I_0$ ) rheostat knob is pointing at the second calibration mark from the left (1.2X). Assume the relay has a minimum pickup current of eight amperes. Multiplying the minimum pickup current by the tap multiplier and the pickup vernier level yields:  
Pickup =  $8 \times 4 \times 1.2 = 38.4A$

Approximately 38A RMS through the  $I_C/3I_0$  current circuit is necessary to pick up the level detector.

### ACCEPTANCE TESTS

Immediately upon receipt of the relay an INSPECTION AND ACCEPTANCE TEST should be made to ensure that no damage has been sustained in shipment and that the relay calibrations have not been disturbed. If the examination or the test indicates that readjustment is necessary, refer to the section on **SERVICING**.

**CAUTION:** WHEN HIPOTTING THE SBC, REMOVE ALL EXTERNAL WIRING FROM TERMINAL 11. DO NOT HIPOT TERMINAL 11. THE REASON IS THAT CAPACITORS C1-C8 ARE RATED FOR 600 VDC AND THE HIPOT VOLTAGE MAY DAMAGE THE CAPACITORS.

Printed card boards must be in place with the nameplate in place. Relay must be in its case with cover installed. Connect all studs of case (except No. 11) together. Apply hipot voltage probes from studs connected together to metal of case. Smoothly raise voltage from zero to 2200 volts RMS, 60 hertz, hold for one second and smoothly lower voltage to zero. Any breakdowns should be corrected before proceeding with test.

These tests may be performed as part of the installation or acceptance tests at the discretion of the user. Since most operating companies use different procedures for acceptance and installation tests, the following section includes all applicable tests that may be performed on these relays.

Setting or checking all SBC relays consist of the following tests and these tests must be performed in the following order.

#### FILL-IN TIMER SETTING

The fill-in timer is essentially an adjustable drop-out timer which is factory set to two milliseconds.

The timer and its associated adjustment potentiometer are located on the "A" card (left card, see Fig. 1). Set up the test circuit shown on Fig. 15 and perform the following instructions:

1. Apply rated DC to relay terminals 9 (+) and 10 (-).
2. Insure that the relay circuit currents are zero.
3. Make the oscilloscope and contact circuits described in Fig. 15, being certain to observe the caution that the scope power cord is ungrounded.

Opening the normally open contact in the circuit removes signal from the timer input and thereby allows for fill-in timer measurement.

Place the scope in an external triggering mode with negative slope and note that upon opening the depressed normally open contact, a positive signal from TP4 goes to "0" volts in about 2 to 2.5 milliseconds. If the measurement is less than or greater than this range, correctly set the time to 2.0 milliseconds by adjusting the potentiometer located in the lower corner of the "A" card.

#### CURRENT DETECTOR PICKUP TEST

Having checked or adjusted the fill-in time setting per above, set up the test current circuit of Fig. 16.

Connect an oscilloscope such that the vertical input is connected to TP4 of the "A" card and reference is connected to TP1 of the "A" card. The oscilloscope power cord should be ungrounded.

The following test is for a fill-in time setting of 2.0 milliseconds:

1. Set all current tap blocks as follows:
 

$I_A$	1X
$I_B$	1X
$I_C/3I_0$	1X
2. Set both pickup vernier pointers to the "1" tap multiplier mark (first calibration line going clockwise).
3. Apply current to the  $I_A$  terminals per Fig. 16 until the oscilloscope indicates a continuous DC output. The input current shall be approximately one (1) ampere.
4. Repeat three (3) above for phase B and phase  $I_C/3I_0$ .
5. Using the procedure above, check the other taps and multiples of current settings.

#### CURRENT DETECTOR PICKUP VERNIER SETTINGS

Use the procedure of the previous section except set the current rheostats to the desired current pickup and secure the rheostats.

## INSTALLATION PROCEDURE

### INTRODUCTION

The location should be clean and dry, free from dust and excessive vibration, and well lighted to facilitate inspection and testing.

The relay should be mounted on a vertical surface. The outline and panel diagram is shown in Fig. 18.

The internal connection diagram for the relay is shown in Fig. 10. The external connections diagram is shown in Fig. 3.

One of the mounting studs or screws should be permanently connected to ground by a conductor not less than No. 12 AWG gage copper wire or its equivalent. This connection is made to ground the relay case. In addition, the terminal designated as "surge ground" on the internal connections diagram must be tied to ground for the surge suppression networks in the relay to perform properly. This surge ground lead should be as short as possible to ensure maximum protection from surges (preferably ten inches or less to reach a solid ground connection).

The relay may be tested without removing it from the panel by using a 12XLA13A test plug. This plug makes connections only with the relay and does not disturb any shorting bars in the case. The 12XLA12A test plug may also be used. Although this test plug allows greater testing flexibility, it also requires CT shorting jumpers and the exercise of greater care since connections are made to both the relay and the external circuitry. Additional information on the XLA test plugs may be obtained from GEI-25372.

All alternating current operated devices are affected by frequency. Since non-sinusoidal waveforms can be analyzed as a fundamental plus harmonics of the fundamental frequency, it follows that alternating current devices (relays) will be affected by the applied waveform. Therefore, in order to properly test alternating current relays it is essential to use a sine wave of current.

**CAUTION:** WHEN HIPOTTING THE SBC, REMOVE ALL EXTERNAL WIRING FROM TERMINAL 11. DO NOT HIPOT TERMINAL 11. THE REASON IS THAT CAPACITORS C1-C8 ARE RATED FOR 600 VDC AND THE HIPOT VOLTAGE MAY DAMAGE THE CAPACITORS.

Printed card boards must be in place with the nameplate in place. Relay must be in its case with cover installed. Connect all studs of case (except No. 11) together. Apply hipot voltage probes from studs connected together to metal of case. Smoothly raise voltage from zero to 2200 volts RMS, 60 hertz, hold for one second and smoothly lower voltage to zero. Any breakdowns should be corrected before proceeding with test.

Since most operating companies use different procedures for installation tests, the section under **ACCEPTANCE TESTS** contains all necessary tests which may be performed as part of the installation procedure at the discretion of the user.

The minimum suggested tests are as follows.

CURRENT DETECTOR PICKUP SETTING

Set the test current circuit of Fig. 16.

Place an oscilloscope on the "A" card TP4 as an indication of current detector pickup. Note that a "0" volt signal denotes dropout and a positive DC signal represents current detector pickup.

As a quick check on each of the relay calibration marks, perform the following:

Place all current multiplier screws in the middle position.

$I_A$	2X
$I_B$	2X
$I_C/3I_0$	2X

Place both pickup vernier rheostat pointers to the first calibration line (i.e., 1X).

Apply test current to each of the three current circuits per Fig. 16 and adjust the current level until the "A" card TP4 indicates that the current detector has just picked up. The current levels should be 1.9-2.1A RMS for a low current model SBC.

Having selected the current detector settings to be used on the system, set the TAP MULTIPLIER plugs to the appropriate range. As an example, a 6A setting should use the 4X TAP MULTIPLIER position. Set up the test circuit of Fig. 16 and set the RMS value of the  $I_A$  current to the desired value. Slowly adjust the  $I_A$  PICKUP VERNIER potentiometer counterclockwise from the "2.5" position until the yellow LED (light emitting diode) turns on. Check that the pickup level on phase B is within five percent of the original setting. Lock the potentiometer and check the pickup setting again. Arrange the  $I_C/3I_0$  circuit of Fig. 16 and calibrate the phase C/3 $I_0$  potentiometer by setting the test current to the desired level while turning the  $I_C/3I_0$  potentiometer counterclockwise from the "2.5" position until the yellow LED turns on. Lock the potentiometer and check that the operate level has not changed.

**PERIODIC CHECKS AND ROUTINE MAINTENANCE**

In view of the vital role of protective relays in the operation of a power system, it is important that a periodic test program be followed. It is recognized that the interval between periodic checks will vary depending upon environment, type of relay and the user's experience with periodic testing. Until the user has accumulated enough experience to select the test interval best suited to his individual requirements, it is suggested that the points listed under **INSTALLATION PROCEDURE** be checked at an interval of from one to two years.

CONTACT CLEANING

For cleaning relay contacts, a flexible burnishing tool should be used. This consists of a flexible strip of metal with an etched-roughened surface, resembling in effect a superfine file. The polishing action is so delicate that no scratches are left, yet it will clean off any corrosion thoroughly and rapidly. The flexibility of



the tool insures the cleaning of the actual points of contact. Do not use knives, files, abrasive paper or cloth of any kind to clean relay contacts.

### SERVICING

Should servicing of the relay become necessary, follow the test procedures as explained in the section titled **ACCEPTANCE TESTS**, for calibration and test of the relay. Telephone relay contact cleaning is located in the section titled **PERIODIC CHECKS AND ROUTINE MAINTENANCE**. Also, see section on **RENEWAL PARTS** for servicing printed circuit cards.

### RECEIVING, HANDLING AND STORAGE

These relays, when not included as part of a control panel will be shipped in cartons designed to protect them against damage. Immediately upon receipt of a relay, examine it for any damage sustained in transit. If injury or damage resulting from rough handling is evident, file a damage claim at once with the transportation company and promptly notify the nearest General Electric Apparatus Sales Office.

Reasonable care should be exercised in unpacking the relay in order that none of the parts are injured or the adjustments disturbed.

If the relays are not to be installed immediately, they should be stored in their original cartons in a place that is free from moisture, dust and metallic chips. Foreign matter collected on the outside of the case may find its way inside when the cover is removed, and cause trouble in the operation of the relay.

### RENEWAL PARTS

It is recommended that sufficient quantities of renewal parts be carried in stock to enable the prompt replacement of any that are worn, broken or damaged.

Should a printed circuit card become inoperative, it is recommended that this card be replaced with a spare. In most instances, the user will be anxious to return the equipment to service as soon as possible and the insertion of a spare card represents the most expeditious means of accomplishing this. The faulty card can then be returned to the factory for repair or replacement.

Although it is not generally recommended, it is possible with the proper equipment and trained personnel to repair cards in the field. This means that a troubleshooting program must isolate the specific component on the card which has failed. By referring to the internal connection diagram for the card, it is possible to trace through the card circuit by signal checking and, hence determine which component has failed. This, however, may be time consuming and if the card is being checked in place in its unit, as is recommended, will extend the outage time of the equipment.

**CAUTION:** GREAT CARE MUST BE TAKEN IN REPLACING COMPONENTS ON THE CARDS. SPECIAL SOLDERING EQUIPMENT SUITABLE FOR USE ON THE DELICATE SOLID-STATE COMPONENTS MUST BE USED AND, EVEN THEN, CARE MUST BE TAKEN NOT TO CAUSE THERMAL DAMAGE TO THE COMPONENTS, AND NOT TO DAMAGE OR BRIDGE OVER THE PRINTED CIRCUIT BUSES. THE REPAIRED AREA MUST BE

RECOVERED WITH A SUITABLE HIGH DI-ELECTRIC PLASTIC COATING TO PREVENT POSSIBLE BREAK-DOWNS ACROSS THE PRINTED CIRCUIT BUSES DUE TO MOISTURE OR DUST.

ADDITIONAL CAUTION: DUAL IN-LINE INTEGRATED CIRCUITS ARE ESPECIALLY DIFFICULT TO REMOVE AND REPLACE WITHOUT SPECIALIZED EQUIPMENT. FURTHERMORE, MANY OF THESE COMPONENTS ARE USED IN PRINTED CIRCUIT CARDS WHICH HAVE BUS RUNS ON BOTH SIDES. THESE ADDITIONAL COMPLICATIONS REQUIRE VERY SPECIAL SOLDERING EQUIPMENT AND REMOVAL TOOLS AS WELL AS ADDITIONAL SKILLS AND TRAINING WHICH MUST BE CONSIDERED BEFORE FIELD REPAIRS ARE ATTEMPTED.

When ordering renewal parts, address the nearest Sales Office of the General Electric Company, specify quantity required, name of part wanted, and give the complete model number of the relay for which the part is required.

List of Illustrations

- Fig. 1 SBC31 Relay Removed from Case (Front View)
- Fig. 2 SBC31 Relay Removed from Case (Rear View)
- Fig. 3 Type SBC31A External Connections
- Fig. 4 Underrated Line Breaker Application
- Fig. 5 Circuit Switcher Protective Application
- Fig. 6 Pickup Time for Suddenly Applied Single Phase Current
- Fig. 7 Pickup Time for Suddenly Applied Three Phase Current
- Fig. 8 Breaker Failure Time Chart for the SBC31 Relay
- Fig. 9 Operating Time for the SBC31 Relay in Breaker Failure Applications
- Fig. 10 Internal Connections Diagram
- Fig. 11 Level Detector and Fill-in Timer ("A" Card) Internal
- Fig. 12 Relay Driver ("C" Card) Internal
- Fig. 13 Full Wave Bridges ("X" Card) Internal
- Fig. 14 Power Supply for the SBC Relay ("Y" Card)
- Fig. 15 Fill-in Time Test Circuit for the SBC Relay
- Fig. 16 Current Detector Test for the SBC31 Relay
- Fig. 17 Timing Test Circuit for the SBC31 Relay
- Fig. 18 Outline and Panel Drilling Dimensions for the SBC Relay

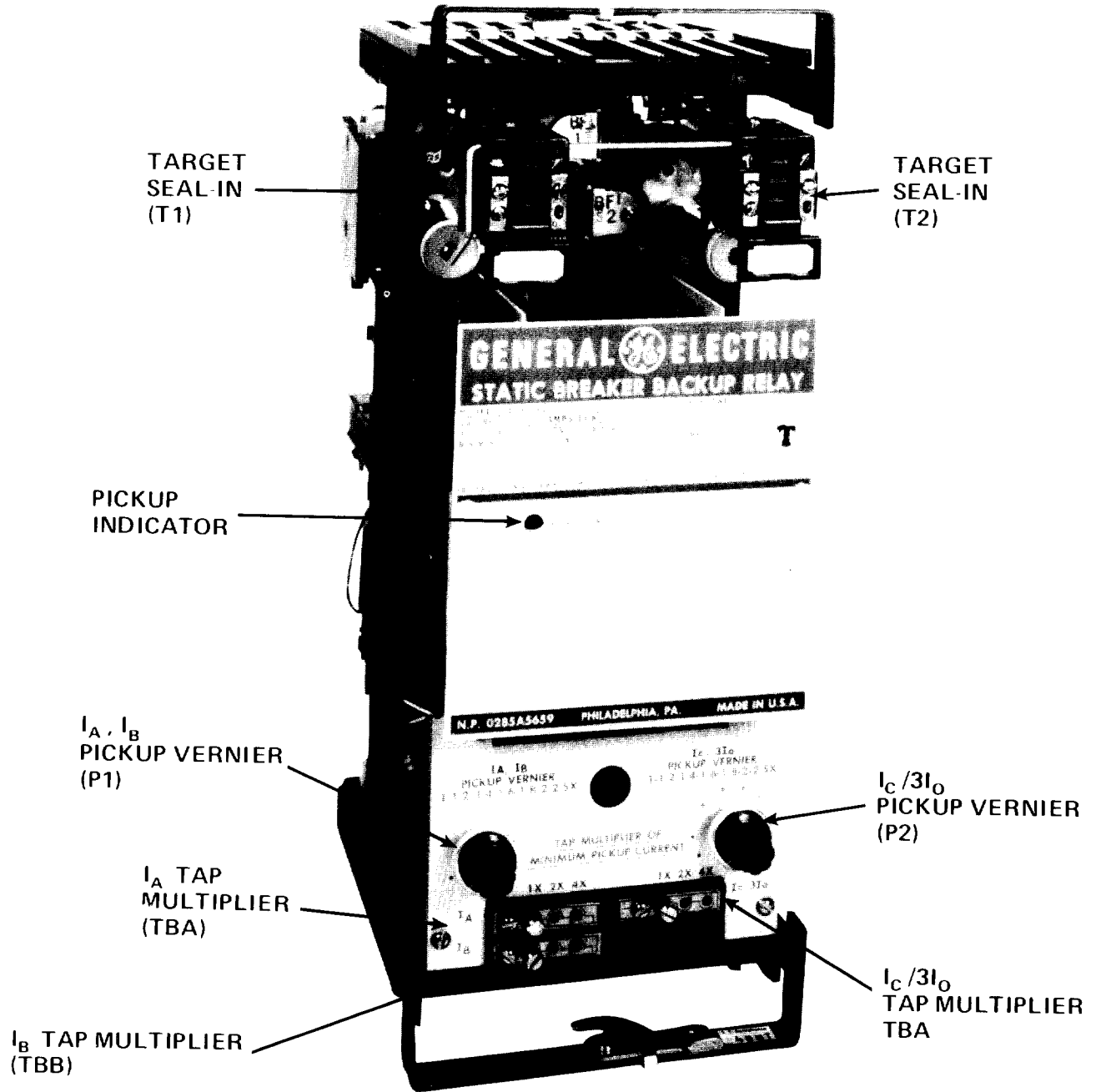

Fig. 1 (8043672) SBC31 Relay Removed from Case (Front View)

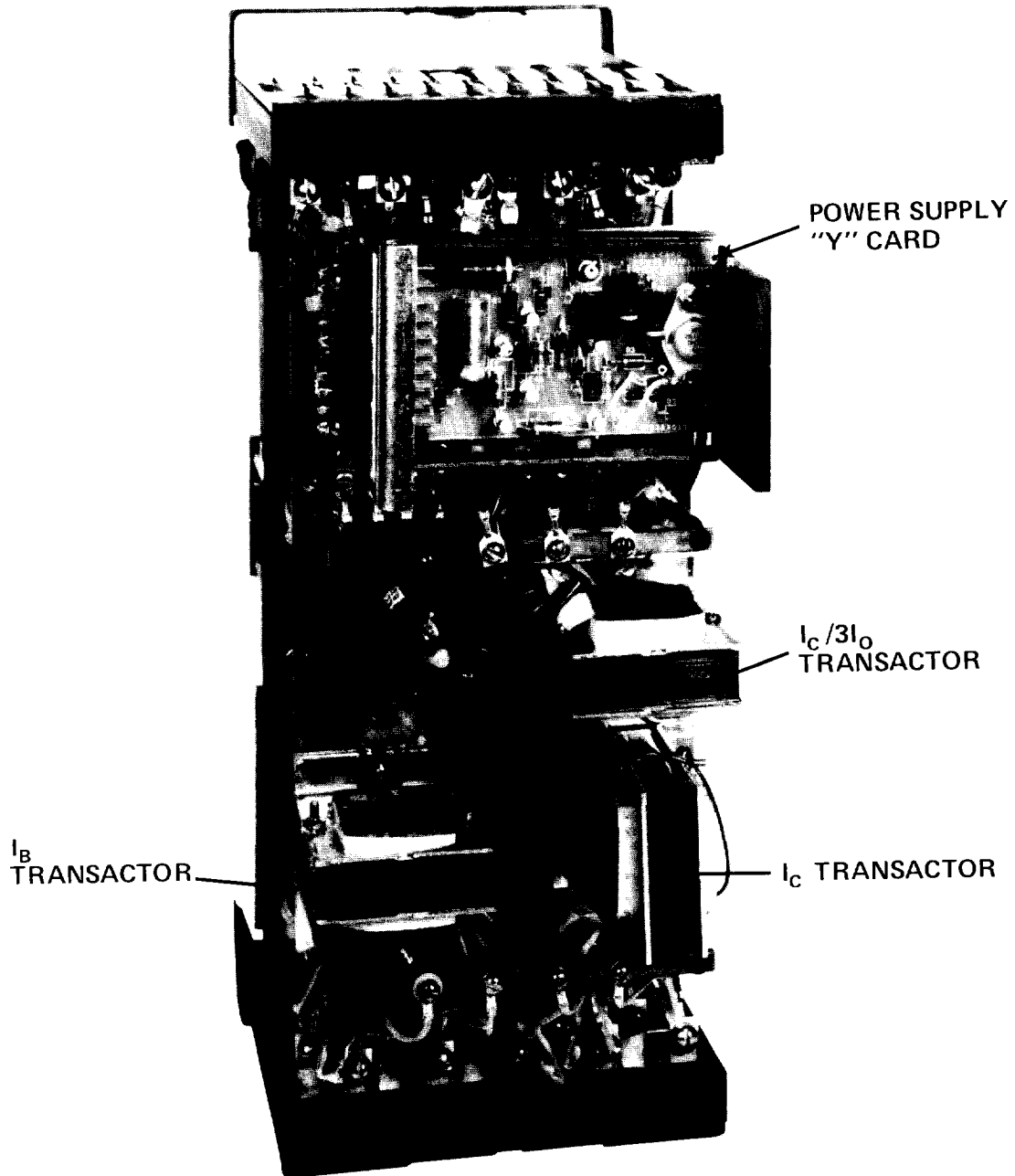
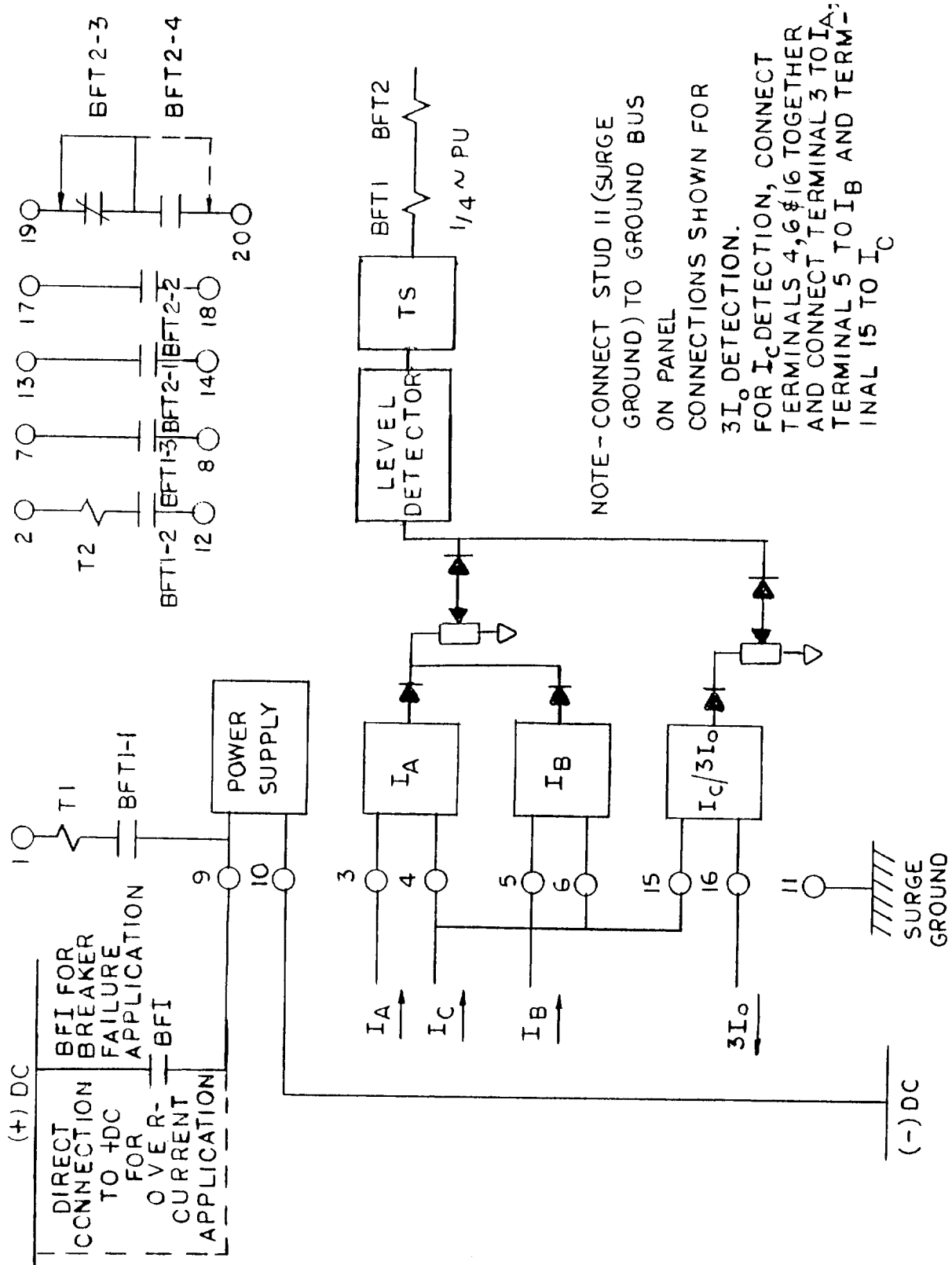

Fig. 2 (8043674) SBC31 Relay Removed from Case (Rear View)



NOTE - CONNECT STUD 11 (SURGE GROUND) TO GROUND BUS ON PANEL

CONNECTIONS SHOWN FOR 3Io DETECTION. FOR IC DETECTION, CONNECT TERMINALS 4, 6 & 16 TOGETHER AND CONNECT TERMINAL 3 TO IA; TERMINAL 5 TO IB AND TERMINAL 15 TO IC

▽ REFERENCE

Fig. 3 (0285A5685-1) Type SBC31A External Connections

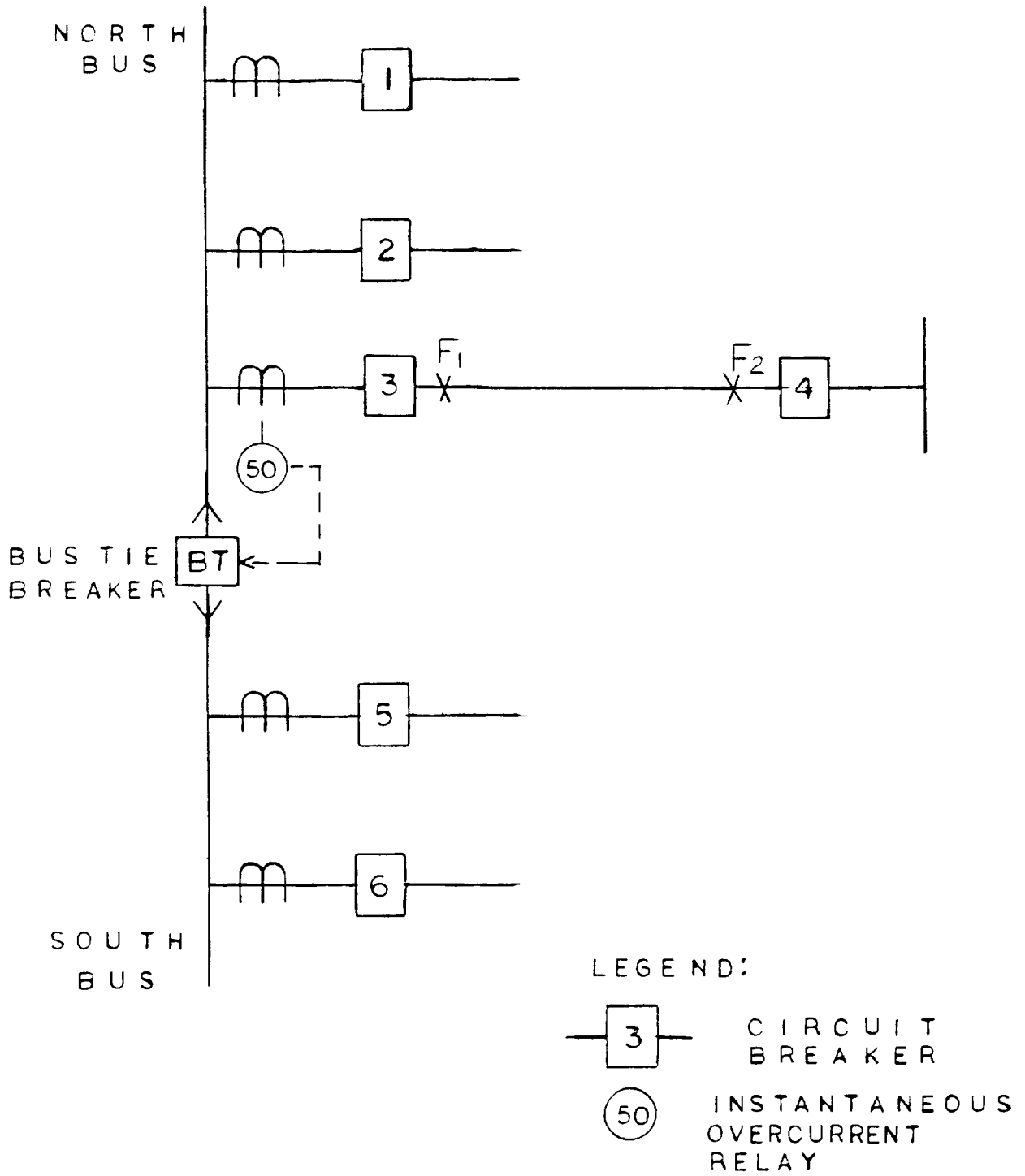
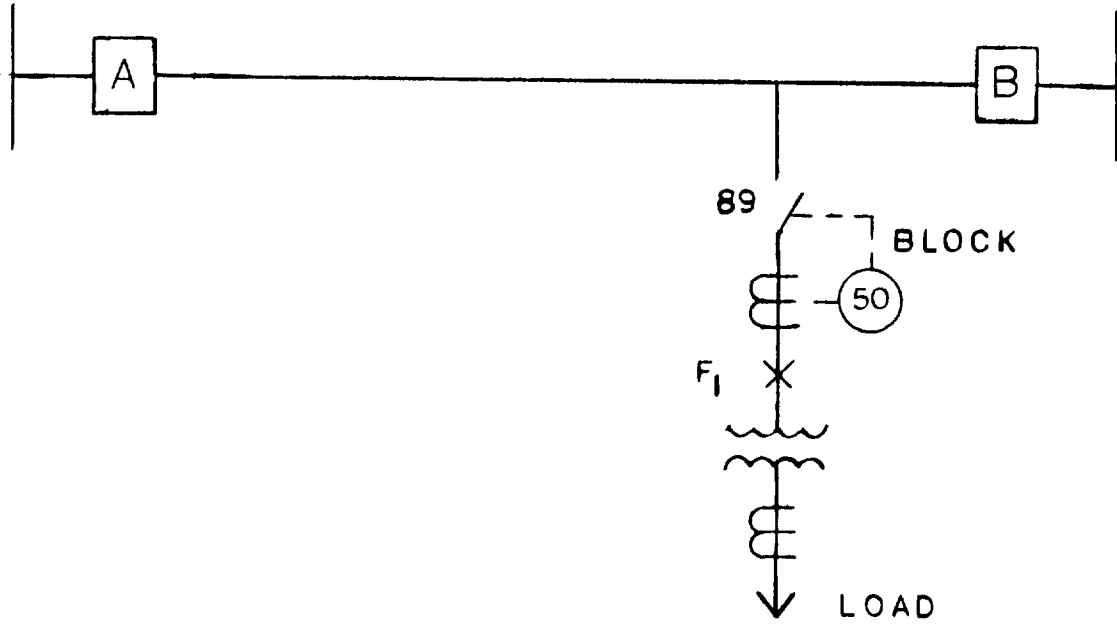

Fig. 4 (0285A6204-0) Underrated Line Breaker Application



LEGEND:



-  INSTANTANEOUS OVERCURRENT RELAY
-  CIRCUIT BREAKER
-  CIRCUIT SWITCHER

Fig. 5 (0285A6205-0) Circuit Switcher Protective Application



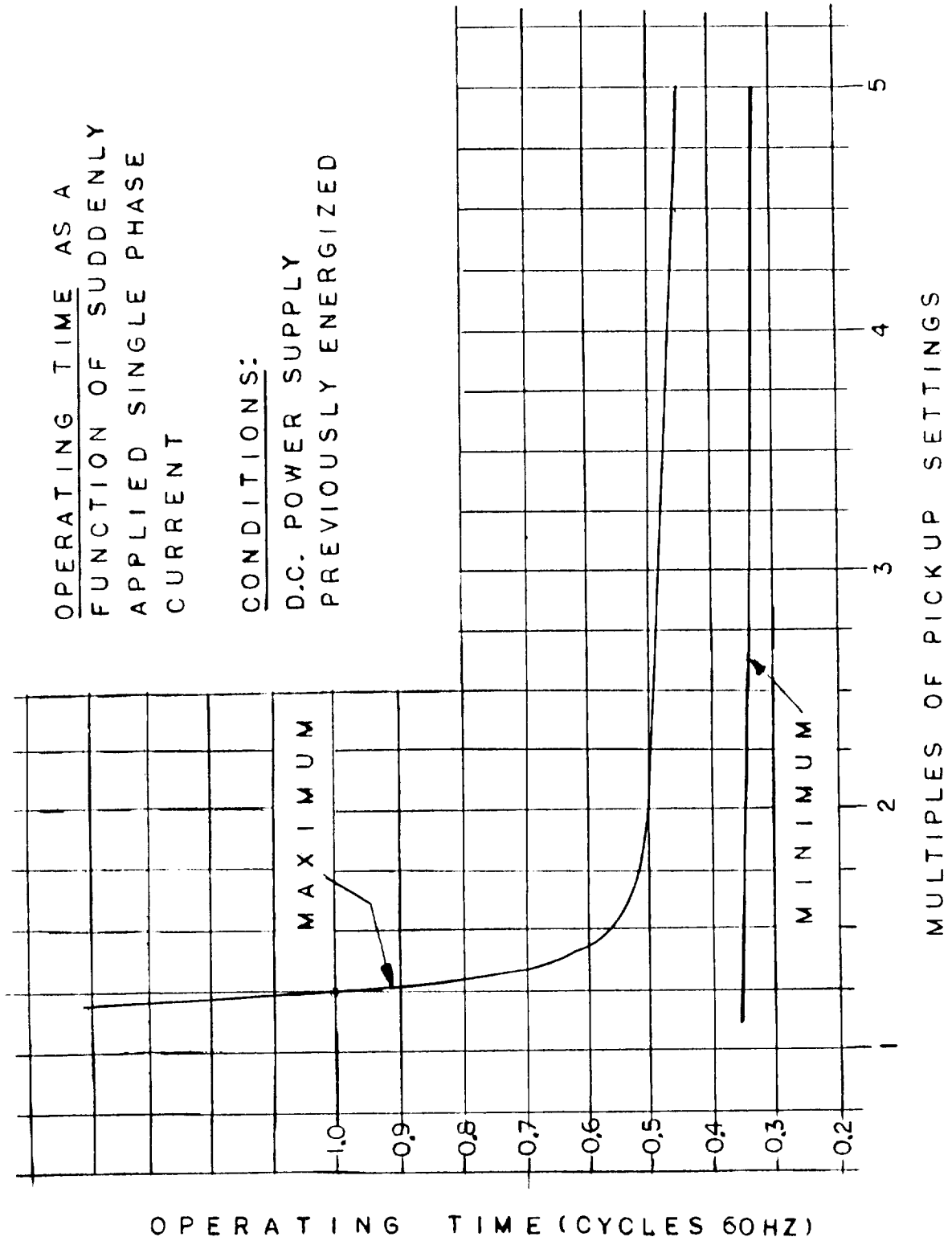

Fig. 6 (0285A6206-0) Pickup Time for Suddenly Applied Single Phase Current

OPERATING TIME AS A FUNCTION OF  
SUDDENLY APPLIED THREE PHASE CURRENT

CONDITIONS:

D.C. POWER SUPPLY PREVIOUSLY ENERGIZED

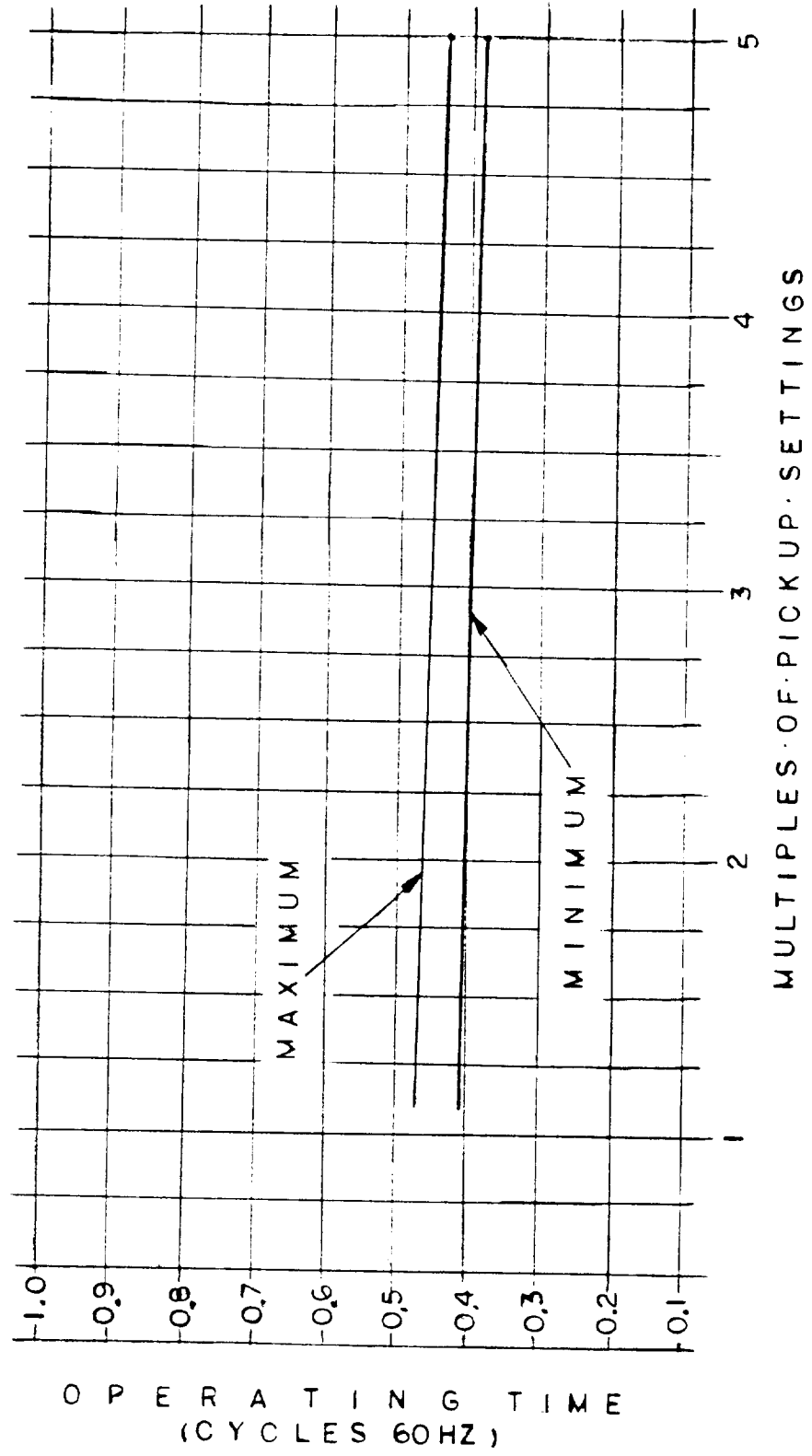

Fig. 7 (0285A6207-0) Pickup Time for Suddenly Applied Three Phase Current

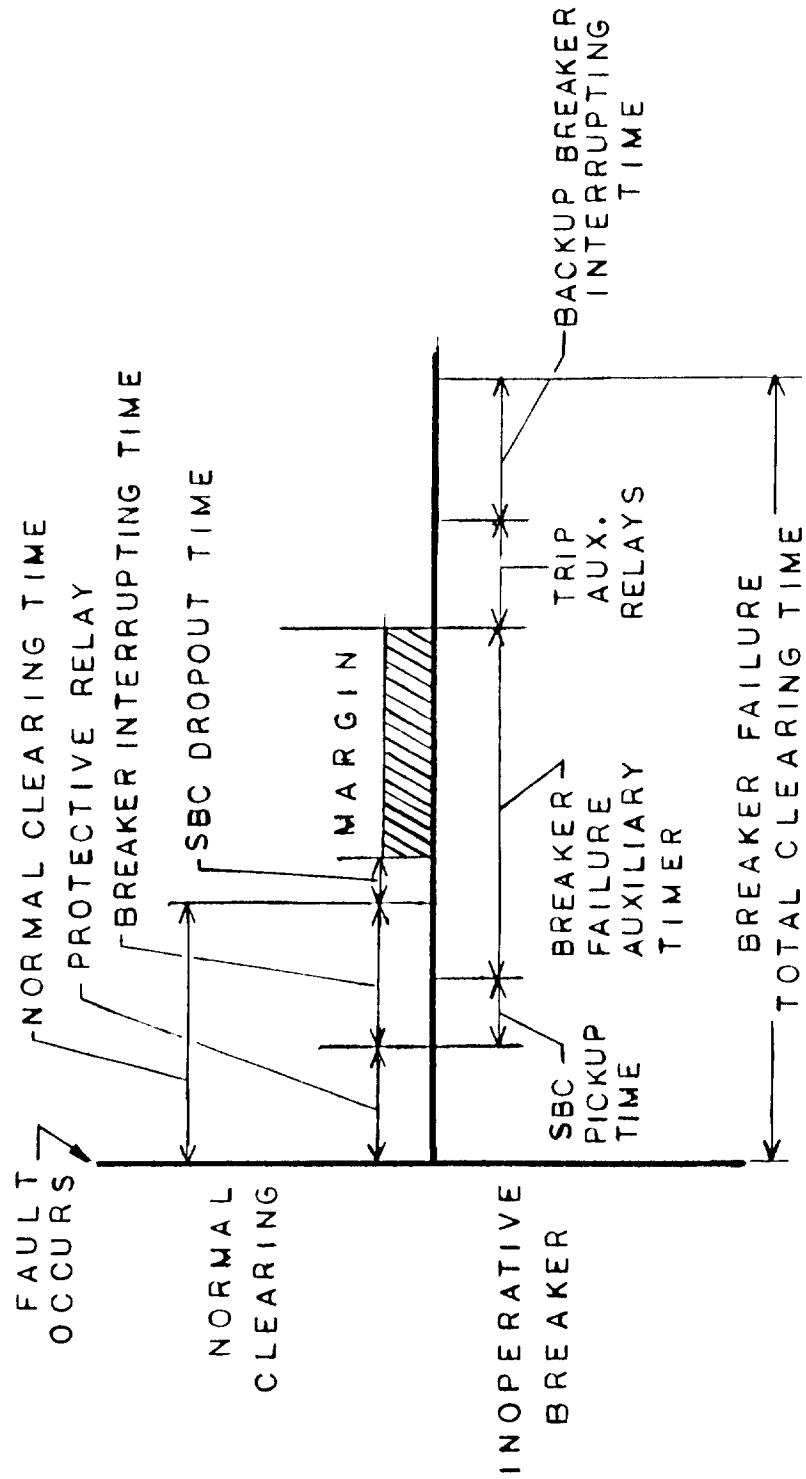

Fig. 8 (0285A6208-0) Breaker Failure Time Chart for the SBC31 Relay

SBC 31 OPERATING TIME FOR BREAKER FAILURE APPLICATIONS  
BREAKER FAILURE DETECTOR OPERATING TIME AS A FUNCTION OF STEADY STATE SINGLE PHASE CURRENT

CONDITIONS:

1. STEADY STATE CURRENT FLOWING PREVIOUSLY
2. D.C. POWER SUPPLY SUDDENLY ENERGIZED

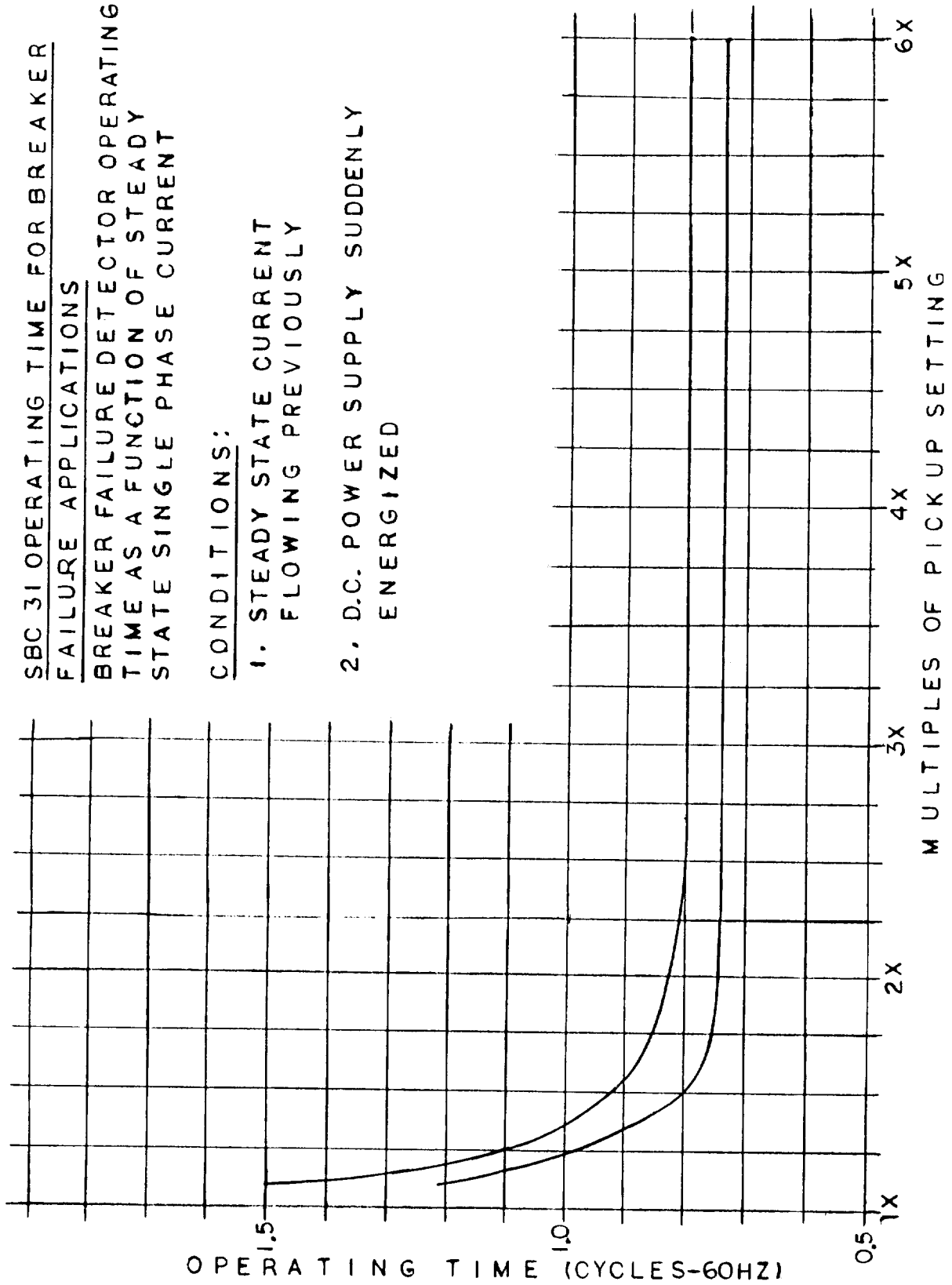

Fig. 9 (0285A6209-0) Operating Time for the SBC31 Relay in Breaker Failure Applications

GEK-65586

NOTES

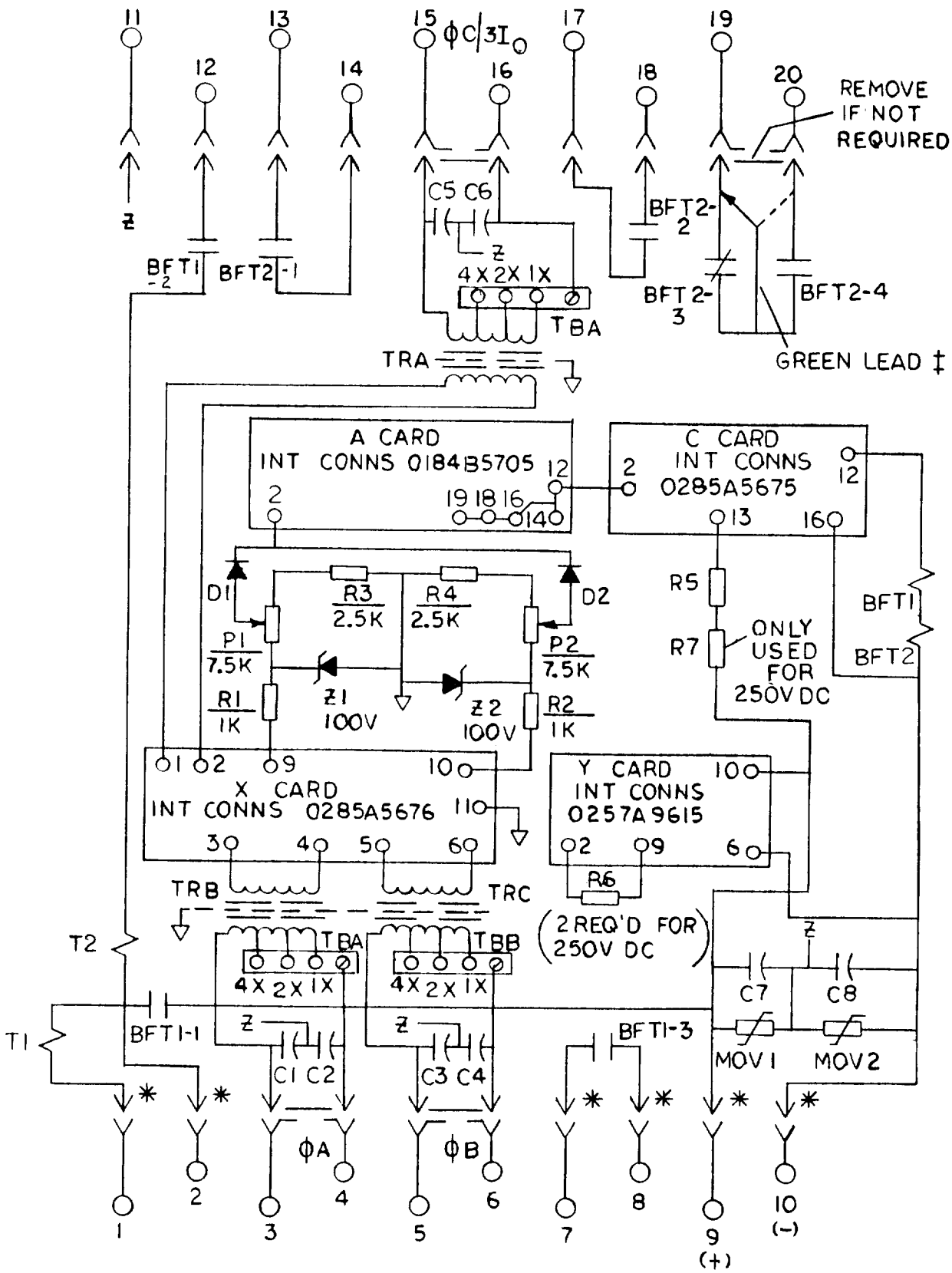

Fig. 10A (0285A5684-0, Sh. 1) Internal Connections Diagram

POWER SUPPLY CONNECTIONS
<u>+10 VOLTS TO PINS</u> A10, C10, Y3
<u>REFERENCE TO PINS</u> A1, A20, C1, C20, X11, Y1
<u>-10 VOLTS TO PINS</u> A11, C11, Y4

- ↓ = POWER SUPPLY REFERENCE
- \* = SHORT FINGER
- T1 = LEFT HAND TARGET
- T2 = RIGHT HAND TARGET
- BFT = BREAKER FAILURE TRIP
- TB = TAP BLOCK
- TR = TRANSACTOR
- Z = SURGE GROUND TERMINAL II
- ‡ = CONNECT NORMALLY OPEN OR NORMALLY CLOSED

V DC	R5 - VALUE	R6 - VALUE	R7 - VALUE
48	400Ω 12W	250Ω 25W	NOT USED
125	1000Ω 25W	1000Ω 25W	NOT USED
250	1000Ω 25W	(2) 1000Ω 25W IN SERIES	1500Ω 25W

Fig. 10B (0285A5684-0, Sh. 2) Internal Connections Diagram

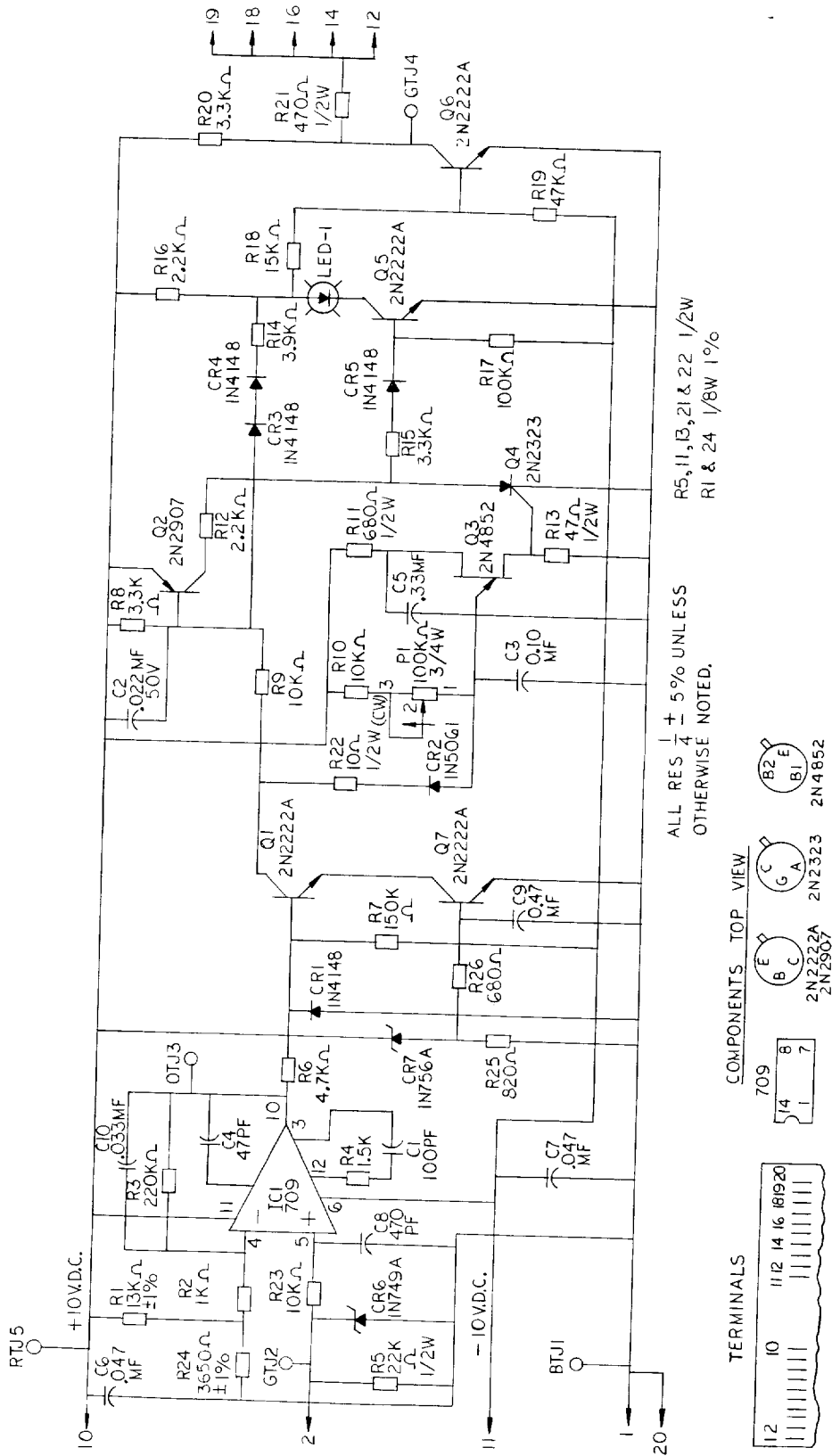

Fig. 11 (0184B5705-1, Sh. 2) Level Detector and Fill-in Timer ("A" Card) Internal



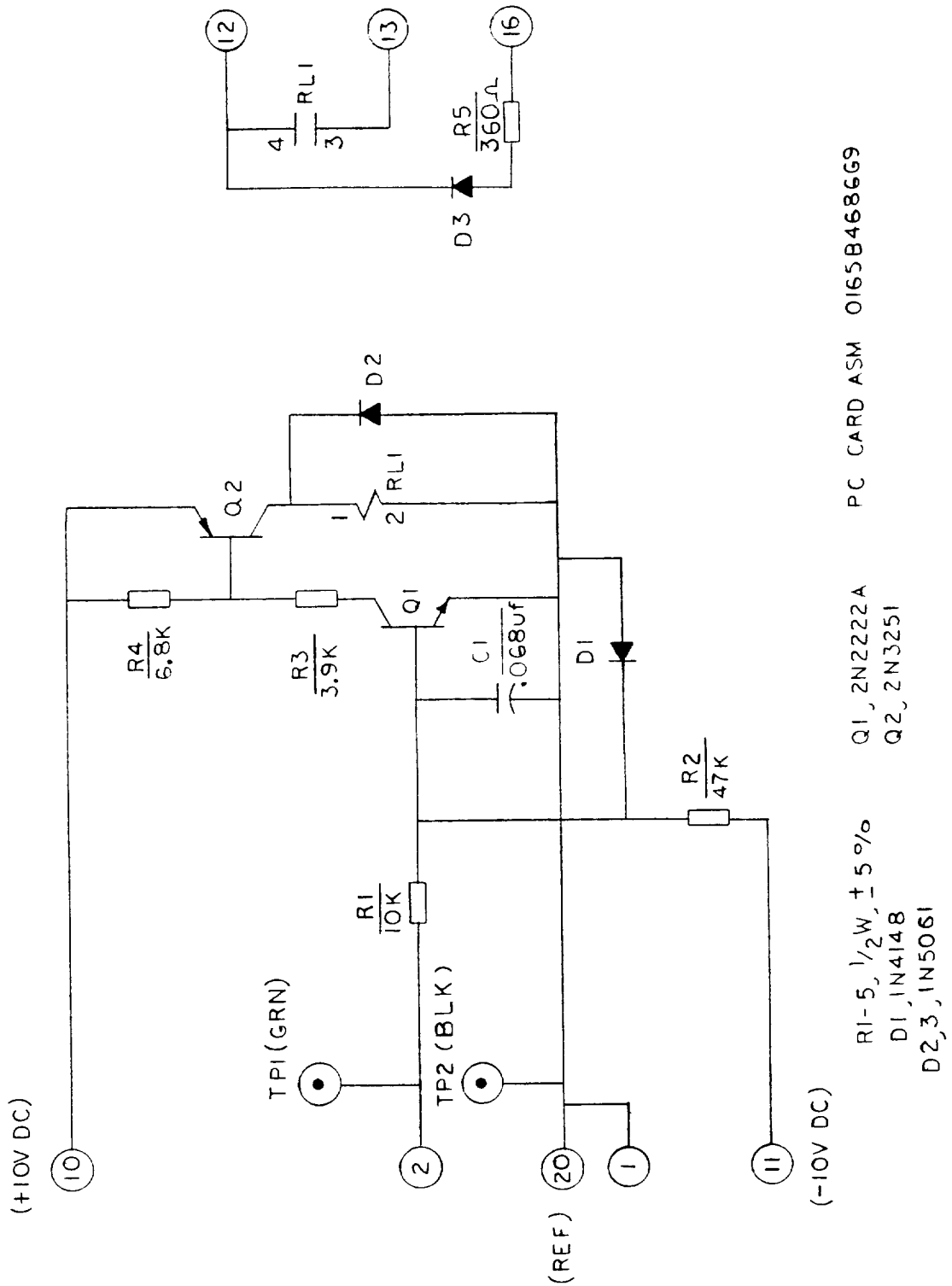
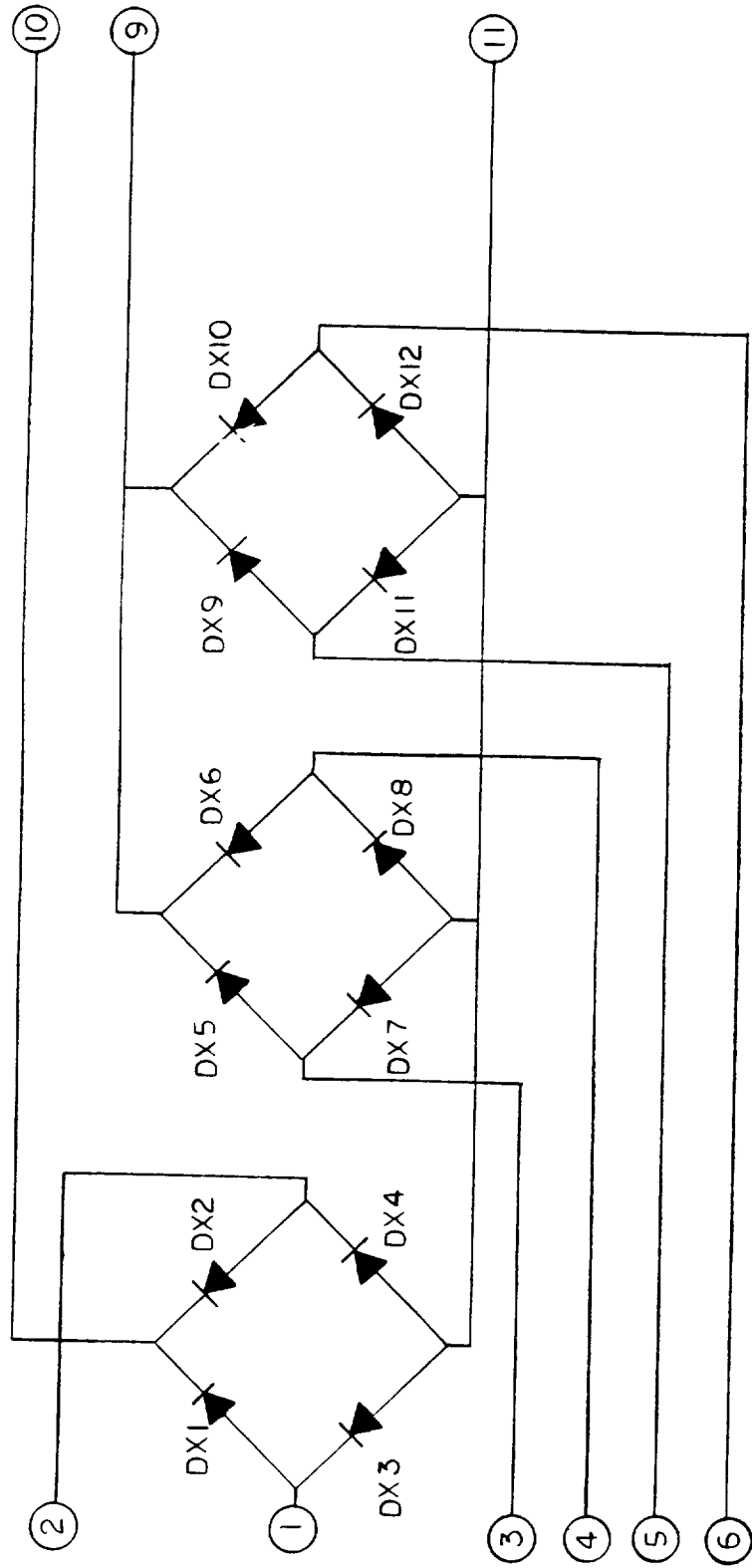
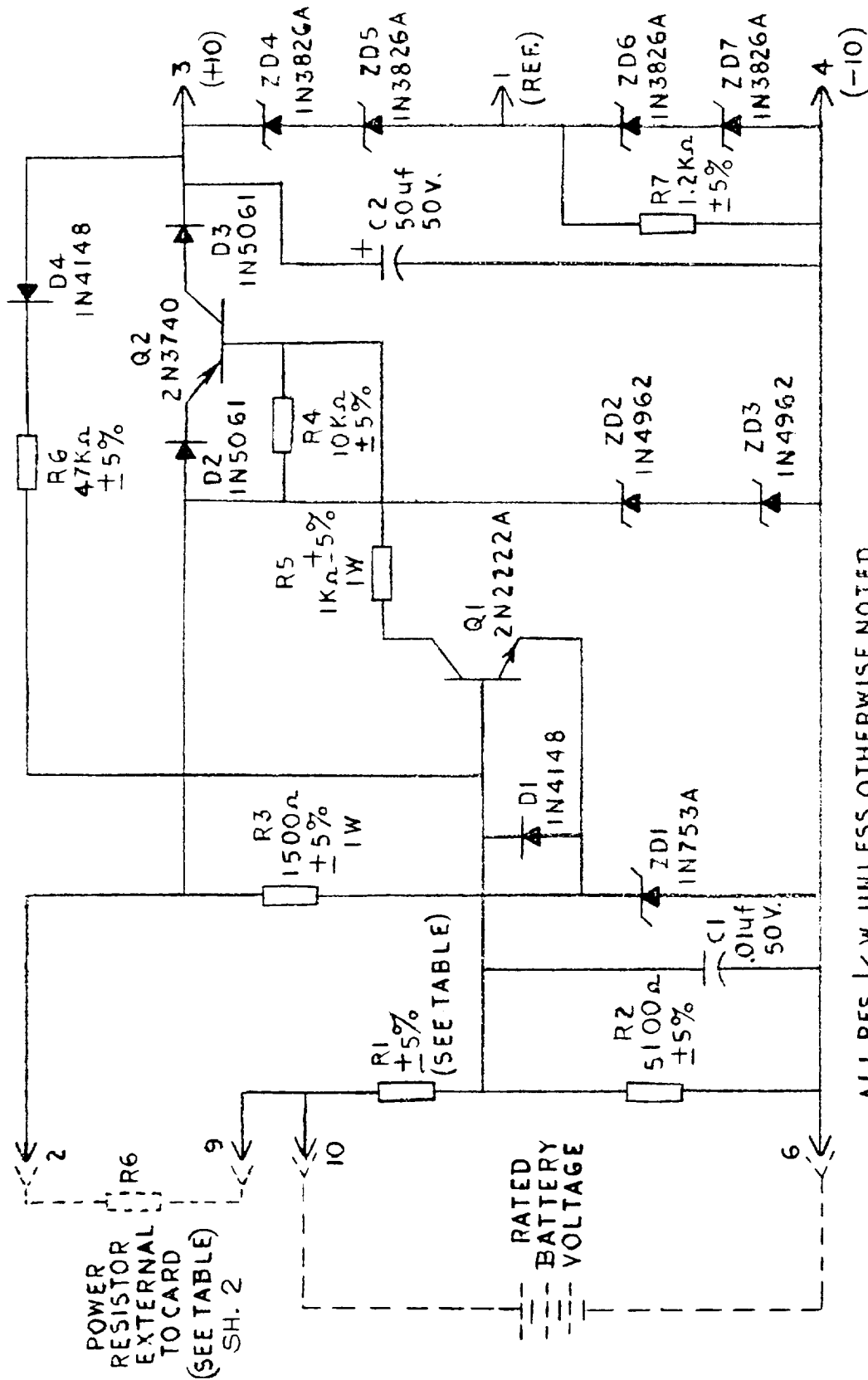

Fig. 12 (0285A5675-0) Relay Driver ("C" Card) Internal



DX1-12, IN5061  
 PC CARD ASM 0165B4796G6

Fig. 13 (0285A5676-0) Full Wave Bridges ("X" Card) Internal



P.C. CARD ASM	VOLTS	EXT RES R6	R1
0183B8056 GR-1	48	250	18 K $\Omega$ 2W
0183B8056 GR-2	125	1000	56 K $\Omega$ 2W
0183B8056 GR-3	250	2000	120 K $\Omega$ 2W
0183B8056 GR-4	220	1800	100 K $\Omega$ 2W

TERMINALS  
1 2 3 4 6 9 10



Fig. 14 (0257A9615-3, Sh. 1 and 2) Power Supply for the SBC Relay (Y" Card)

INSTRUCTIONS:

1. APPLY RATED DC TO RELAY TERMINALS 9 (+) AND 10 (-).
2. CHECK THAT THE CT CURRENTS INTO THE RELAY CIRCUITS EQUAL ZERO.
3. SET UP OSCILLOSCOPE AND CONTACT CIRCUITS AS SHOWN BELOW.
4. BE SURE THAT THE OSCILLOSCOPE POWER CORD IS UNGROUNDED.

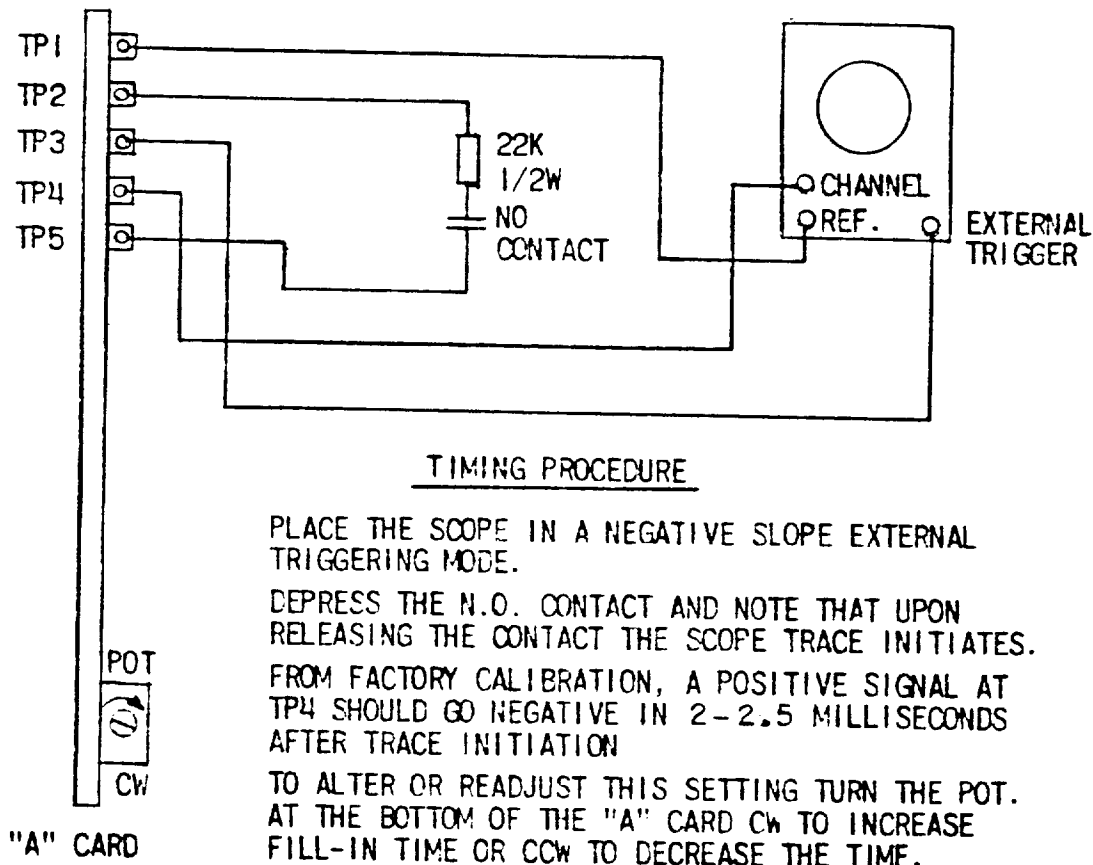

Fig. 15 (0285A6210-0) Fill-in Time Test Circuit for the SBC Relay

CAUTION: USE XLA13 TEST PLUG. SYSTEM OUTPUT CIRCUITS MUST BE REMOVED FOR TEST.

1. NOTE POLARITY ON TERMINAL #9 (+) AND #10 (-).

2. MONITOR PICKUP LED ON "A" CARD (TURNS ON FOR PICKUP).

3. APPLY CURRENT TO RELAY TERMINALS AS SHOWN IN TABLE BELOW.

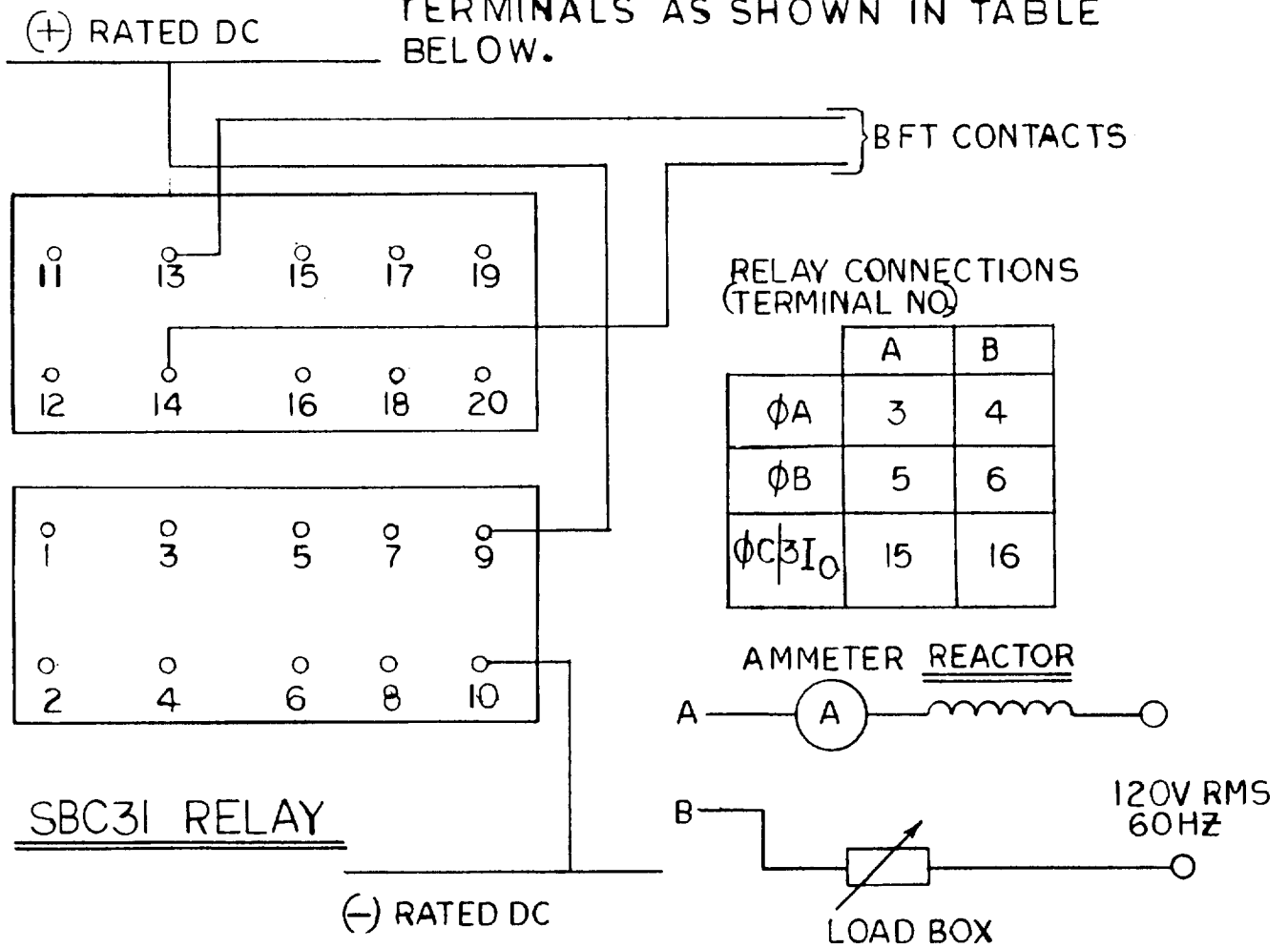

Fig. 16 (0246A2204-1, Sh. 2) Current Detector Test for the SBC31 Relay

CAUTION: SYSTEM OUTPUT CIRCUITS MUST BE REMOVED FOR TEST (USE AN XLA13 TEST PLUG).

- a. SET AMMETER CURRENT (A) TO 5 TIMES THE PICK UP CURRENT LEVEL.
- b. INITIATE TIMING SEQUENCE BY OPENING THE SWITCH (SW 1)

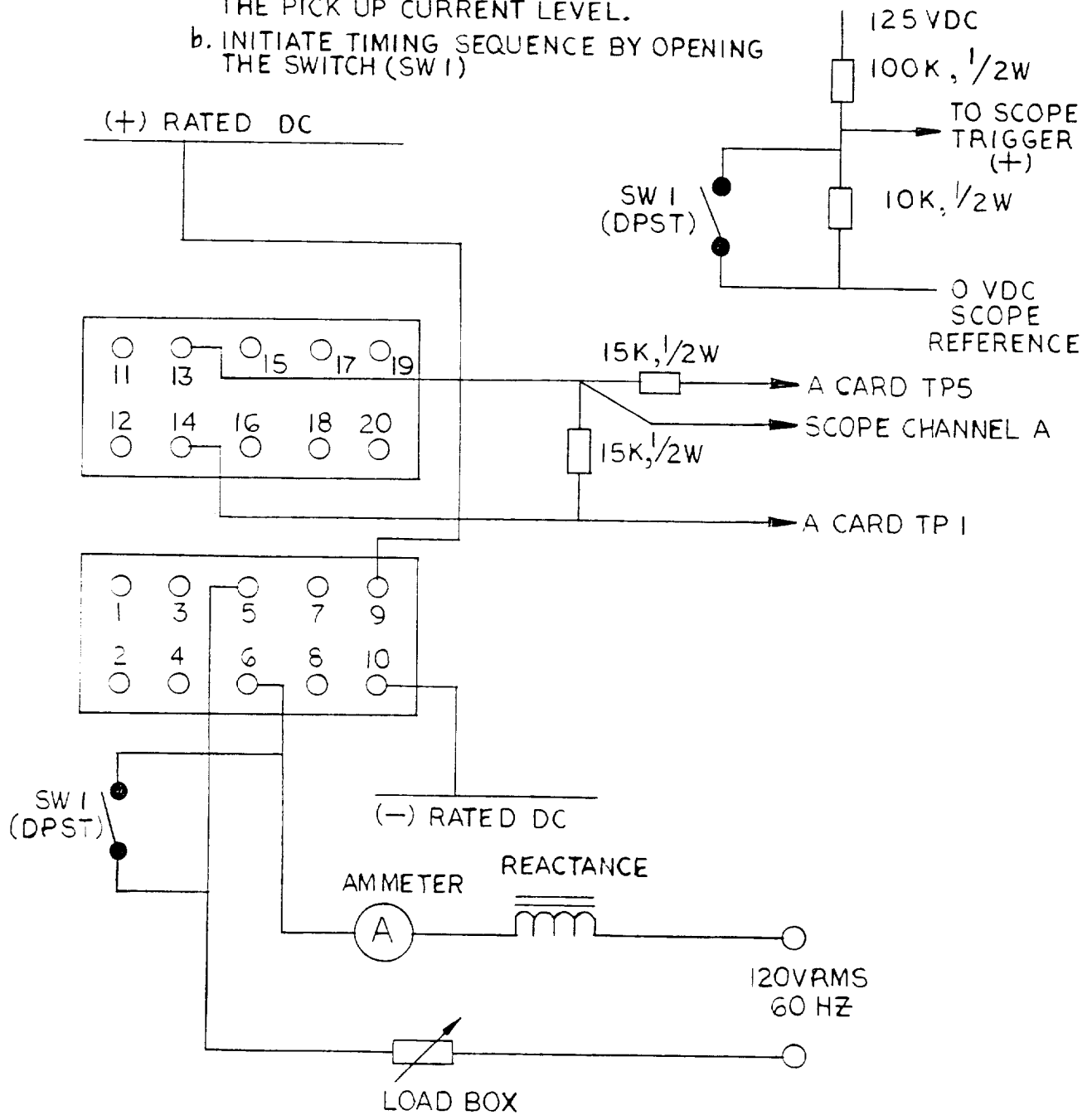

FIG 22

(0246A2202 SH 2-0) TIMING TEST CIRCUIT FOR THE SBC 31 RELAY

Fig. 17 (0246A2202-1, Sh. 2) Timing Test Circuit for the SBC31 Relay

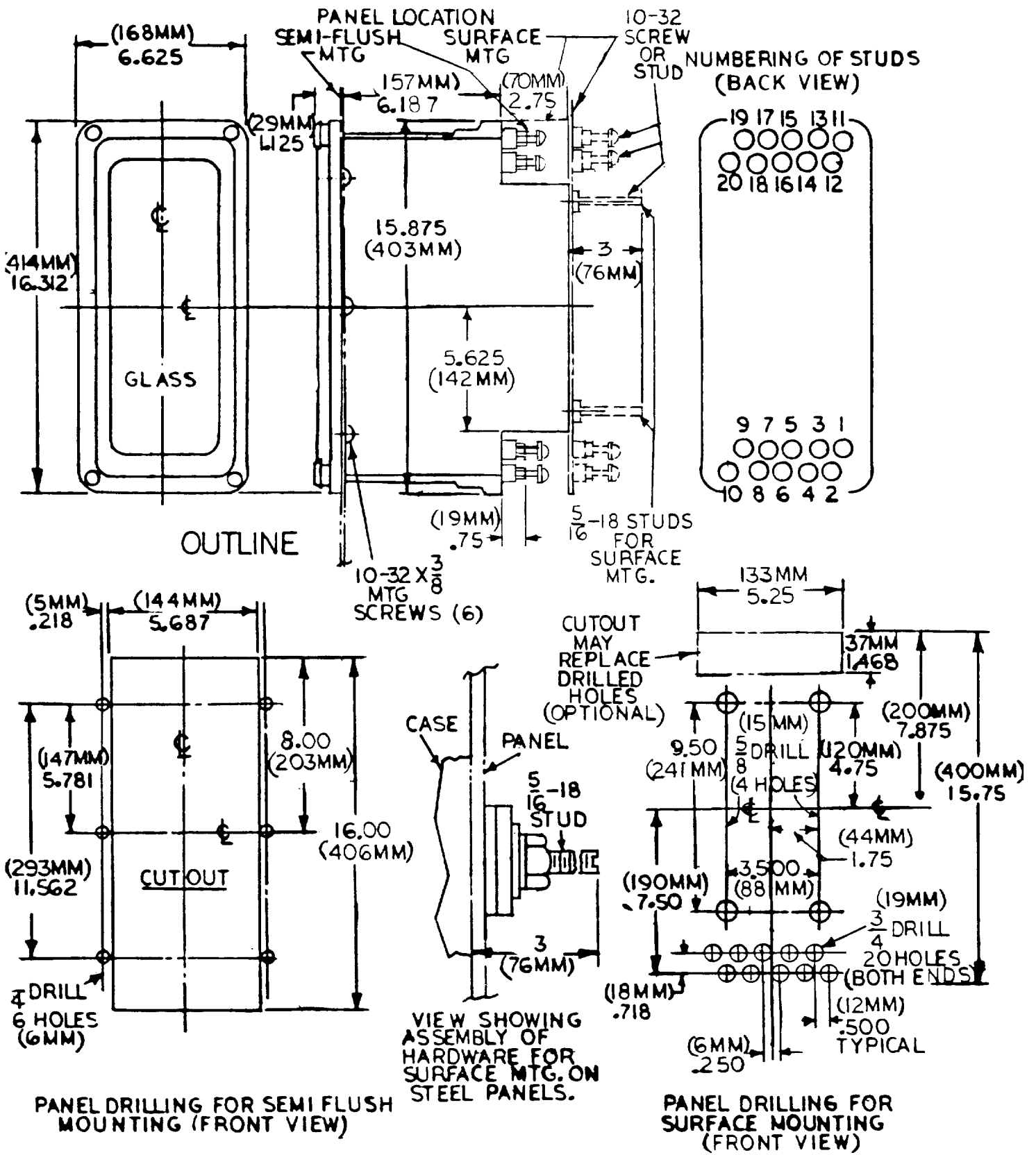

Fig. 18 (0227A2485-1) Outline and Panel Drilling Dimensions for the SBC Relay



---

***GE Power Management***

**215 Anderson Avenue  
Markham, Ontario  
Canada L6E 1B3  
Tel: (905) 294-6222  
Fax: (905) 201-2098  
[www.ge.com/indsys/pm](http://www.ge.com/indsys/pm)**