



INSTRUCTIONS

GEK-86036
Insert Booklet GEK-36807

STATIC TIME-OVERCURRENT RELAY

TYPE 12SFC99AD(-)A

INTRODUCTION

This instruction book, together with insert booklet GEK-36807, forms the instructions for the SFC99AD special relay.

DESCRIPTION

The SFC99AD relay is similar to the SFC152B3 except the time characteristic is a definite time, which can be set for a time delay from 0.1 second to 10 seconds. Operating frequency is 50/60 hertz. A hi-seismic instantaneous unit with pickup adjustable from 2 to 16 amperes is included. The tap current pickup settings are adjustable in steps of 0.1 ampere, from 0.5 to 4.0 amperes.

The time current curve is shown in Figure 1. The time setting is determined by the time dial rotary switch and the time dial vernier pot. Time curves 1 through 10 in Figure 1 are for the time dial vernier set at the "0" position. The time dial rotary switch has ten positions, numbered 1 through 10, which correspond to the curves on Figure 1. Turning the time dial vernier counterclockwise from the "0" position decreases the time delay from the integer value N to $(N - 0.9)$.

The time dial vernier markings are shown in Figure 2. Figure 3 and Figure 4 show the internal connections for the relay and the printed circuit card, respectively.

These instructions do not purport to cover all details or variations in equipment nor to provide for every possible contingency to be met in connection with installation, operation or maintenance. Should further information be desired or should particular problems arise which are not covered sufficiently for the purchaser's purposes, the matter should be referred to the General Electric Company.

To the extent required the products described herein meet applicable ANSI, IEEE and NEMA standards; but no such assurance is given with respect to local codes and ordinances because they vary greatly.

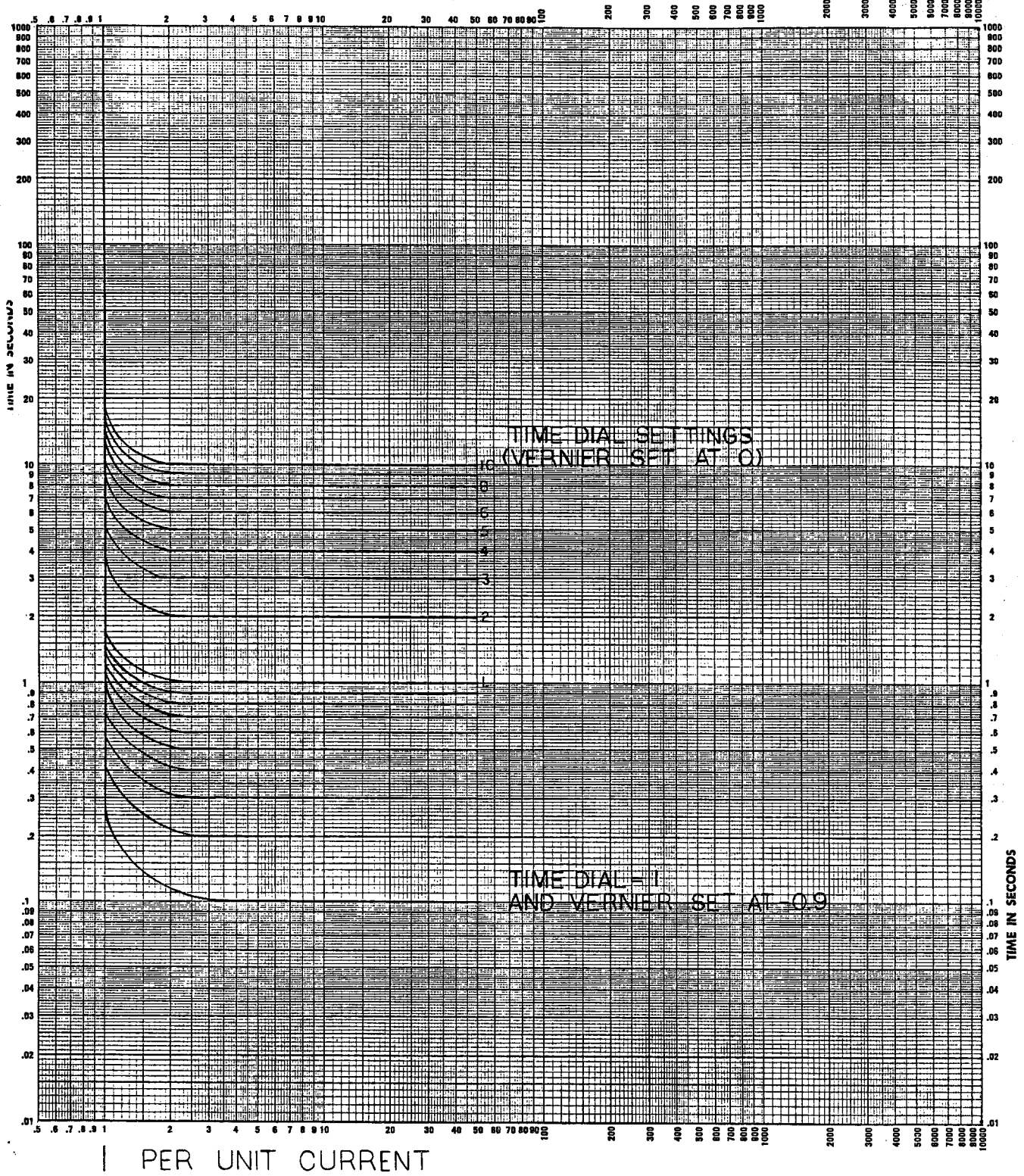

Figure 1 (0138B7645-0) Time Curves for Type SFC99AD Relay

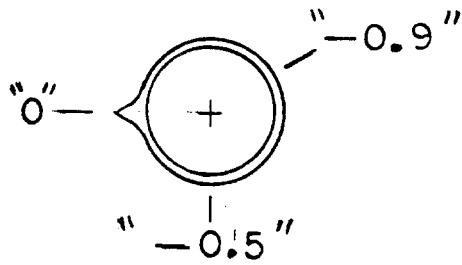

Figure 2 (0285A6735-0) Time Dial Vernier Calibration Points

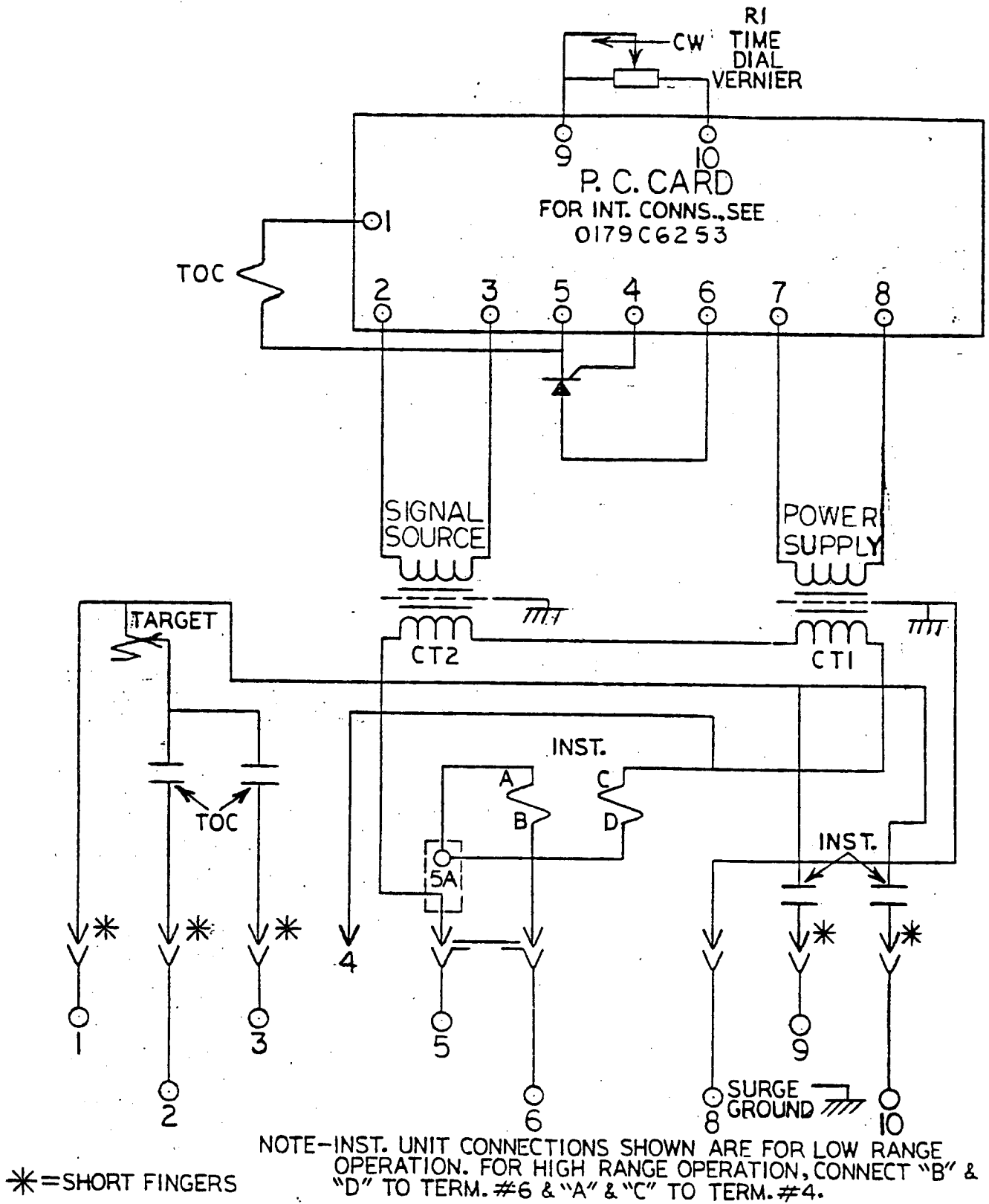

Figure 3 (0285A6167-0) Internal Connection Diagram for Type SFC99AD Relay

**GENERAL ELECTRIC COMPANY
POWER SYSTEMS MANAGEMENT BUSINESS DEPT.**

GENERAL  ELECTRIC