



INSTRUCTIONS

G EK- 34019

TYPE SLA51A

GENERAL  ELECTRIC

CONTENTS

	<u>PAGE</u>
DESCRIPTION.....	3
APPLICATION.....	3
RATINGS.....	3
BURDENS.....	4
OPERATING PRINCIPLE.....	4
A. LOGIC CIRCUIT.....	4
B. CONTACT CONVERTERS.....	4
CC1.....	4
CC2.....	4
C. DATA MONITORING POINTS.....	4
D. CHANNEL INTERFACE.....	4
SETTINGS.....	4
CONSTRUCTION.....	5
RECEIVING, HANDLING AND STORAGE.....	5
TEST INSTRUCTIONS.....	5
CAUTION.....	5
A. GENERAL.....	6
B. OPERATIONAL CHECKS.....	6
C. TEST CARD ADAPTER.....	6
D. TIMER ADJUSTMENTS AND TESTS.....	6
TABLE I.....	6
E. OVERALL EQUIPMENT TESTS.....	6
MAINTENANCE.....	7
A. PERIODIC TESTS.....	7
B. TROUBLE SHOOTING.....	7
C. SPARE PARTS.....	7

DESCRIPTION

The SLA51A relay is an auxiliary logic relay designed to be used in directional comparison ON-OFF carrier schemes. The relay contains the necessary logic to interpret output signals from associated measuring functions and translate them to an appropriate auxiliary output and tripping relay. In addition to the SLA51A relay, appropriate ground and phase relays plus a power supply and auxiliary tripping relay are required to complete a particular relaying scheme.

The type SLA51A relay is packaged in a four rack unit enclosed metal case. The relay is suitable for mounting in a 19 inch rack and the mounting and outline dimensions are shown in Figure 1. Internal connections for the SLA51A relay are shown in Figure 2, and the component and card locations are shown in Figure 3.

APPLICATION

The SLA51A relay is designed to operate in conjunction with appropriate phase and ground relays in a directional comparison ON-OFF carrier blocking scheme.

Protection features required in a relaying scheme often vary from scheme to scheme and it is sometimes desirable to provide certain features initially with the scheme or to provide features so that they may be added at a later date in the field. To this end, the SLA51A design has incorporated circuit flexibility to permit implementation of certain optional features. Printed circuit cards L108 and T102, shown dotted in Figure 2, are used whenever out-of-step detection is required. Matrix blocks "R", "Y", "G" and "B", each with a number of points, are provided in all SLA51A relays to permit various logic arrangements to be made simply by connecting jumper leads between appropriate points. For example, a jumper between G6 and B5, shown dotted in Figure 2, will allow the out-of-step detection option to block all pilot tripping by applying the NOT input to AND7. On the other hand, jumpering between G6 and B6 will block reclosing by applying the NOT input to the appropriate AND function in the associated SLAT tripping relay. These examples can best be understood by referring to the overall logic diagram and instruction books supplied with a particular relaying scheme.

Various points in the logic can be monitored by providing jumpers from any of the available matrix points to plugs located on the rear of the SLA51A relay. The plugs may be provided initially with the equipment or added at a later date. This option is further described in paragraph "C", "Data Monitoring Points", under the section headed OPERATING PRINCIPLES.

For the specific options and the logic arrangement supplied with a particular scheme, refer to the logic diagram and logic descriptive writeup supplied with that scheme. If it is desired to make logic changes at a later date, the diagrams and instruction books supplied with a particular scheme should be studied to determine the means for implementing the changes. If, after study of the diagrams, further assistance is required, contact the nearest General Electric District Sales Office.

There are no measuring functions to be set in the SLA51A relay, but there is included certain timers that must be set in accordance with the demands of the particular system to be protected. Refer to the section under SETTINGS for a description of these timers and for suggestions to be used in making the settings.

RATINGS

The Type SLA51A relay is designed for use in an environment where the air temperature outside the relay case does not exceed -20°C or $+65^{\circ}\text{C}$.

The Type SLA51A relay requires ± 15 VDC power source which can be obtained from a Type SSA power supply.

Each contact converter in this relay has a link for selecting the proper voltage for the coil circuit of the contact converter. The three possible voltages are 48 VDC, 125 VDC and 250 VDC.

These instructions do not purport to cover all details or variations in equipment nor to provide for every possible contingency to be met in connection with installation, operation or maintenance. Should further information be desired or should particular problems arise which are not covered sufficiently for the purchaser's purposes, the matter should be referred to the General Electric Company.

BURDENS

The SLA51A relay presents a burden of 220 ma to the +15 VDC supply of the Type SSA power supply.

Each contact converter, when energized, will draw approximately 10 ma. from the station battery, regardless of tap setting.

OPERATING PRINCIPLESA. LOGIC CIRCUIT

The functions of the Type SLA51A relay involve basic logic (AND, OR, AND NOT) where the presence or absence of signals, rather than their magnitude, controls the operation. Signals are measured with respect to a reference bus accessible at TP1. In general, a signal below 1 VDC represents an OFF or LOGIC ZERO condition; an ON or LOGIC ONE condition is represented by a signal of approximately +15 VDC.

The symbols used on the internal connection diagram (Figure B) are explained by the legend shown in Figure 4.

The matrix block options shown in the internal connections of the SLA51A relay are provided at the factory. The connections are shown on the associated overall logic and are listed on the associated option chart. A sample option chart for the Type SLA51A relay is shown in Figure 5.

B. CONTACT CONVERTERS

The purpose of this function is to convert a contact operation into a signal that is compatible with the logic circuit of the Type SLA51A relay. These contact converters are labeled CC1 and CC2. These contact converters have a non-adjustable 4 millisecond pickup delay.

CC1

Contact converter 1 is energized by an external contact to stop carrier transmission.

CC2

Contact converter 2, when energized, prevents relay carrier tripping and relay control of carrier but permits auxiliary control of carrier.

C. DATA MONITORING POINTS

Optional Data Monitoring Points can be brought out from the matrix block to plugs mounted in available knockouts at the rear of the SLA51A relay. Each plug contains nine monitoring points and reference. When ordered, the selected monitoring points on the matrix block are listed on the option chart which represents the factory wiring configuration for the relay options. Changes in selection of monitored points may be easily made, but this must be done inside the relay. If monitoring points are not ordered, they may be provided at a later date by adding the cable plug(s) and associated wiring as required.

To monitor these points an additional piece of equipment termed a Data Logging Amplifier is required.

D. CHANNEL INTERFACE

The logic of the Type SLA51A relay includes an isolation interface (Figure 6) between the relays in the scheme and the associated channel. The circuitry of the isolation interface provides a signal path but maintains metallic isolation. This feature makes it possible to maintain isolation between the DC supply used for the relays and that employed by the channel.

When pins 9 and 10 are both connected to relay reference, a metallically separate positive logic signal appears at pin 11 with respect to 12. The output from the isolation interface is a 5 VDC, 20 ma. signal.

SETTINGS

There are two timers in the SLA51A relay that may require field adjustment.

The 3/50 timer is part of the comparer-integrator scheme. The normal three millisecond pickup setting is intended to provide coordination between receiver input and the MT input to the comparer AND7.

The pickup setting allows for the transmitter-receiver operating time plus the signal propagation time. A safety margin of at least one (1) millisecond should be added when setting the pickup of this timer. For longer transmitter-receiver operating times, such as with narrow band carrier, a longer pickup time should be considered. Long transmission lines (longer signal propagation time) may also require that the pickup setting be increased. It should be remembered that tripping will be delayed in accordance with the pickup setting of this timer. The purpose of the reset delay of this timer is to hold off carrier for some time after tripping and so ensure that the remote relay will have ample time to operate.

The 2.5/16 timer in the SLY and A/40 timer in the SLA51A are part of the out-of-step detection scheme. The 2.5/16 timer forms a "tomato" (outer) characteristic; thus the distance a swing must travel before the MHO (inner) characteristic is encountered is determined by the pickup setting of this timer. The A/40 timer is used to measure the time of travel between the outer and inner characteristic. An out-of-step condition will be detected when both timers are adjusted properly. The setting of both timers should be based on the results of system swing studies.

Further details for setting these timers can be found in the logic description provided with each static relaying scheme.

CONSTRUCTION

The SLA51A relay is packaged in an enclosed metal case with hinged front covers and removable top cover. The outline and mounting dimensions of the case and the physical location of the components are shown in Figures 1 and 3 respectively.

The SLA51A relay contains printed circuit cards identified by a code number such as A111, T102, L104 where A designates auxiliary function, T designates time delay function, and L designates logic function. The printed circuit cards plug in from the front of the unit. The sockets are marked with letter designations or "addresses" (D, E, F, etc.) which appear on the guide strips in front of each socket, on the component location drawing, on the internal connection diagram and on the printed circuit card. The test points (TP1, TP2, etc.) shown on the internal connection diagram are connected to instrument jacks on a test card in position T or AT with TP1 at the top of the AT card. *TP10 is tied to +15 VDC through a 1.5K resistor. This resistor limits the current when TP10 is used to supply a logic signal to a card.

Other logic options are selected by means of taper tip jumpers and matrix blocks. These matrix blocks are located in the rear of the unit as shown in Figure 3. The green (G) matrix block has ten points in two 5 point common groups. The black (B) matrix block has 20 individual matrix points. The red (R) block has 20 points which are grouped in pairs. The yellow (Y) block has 20 points which are grouped in 10 common points; 1 to 10 are tied to +15 VDC, 11 to 20 are tied to reference. A tool for inserting and removing the taper tip jumpers is supplied with each relay.

RECEIVING, HANDLING AND STORAGE

These relays will normally be supplied as a part of a static relay equipment, mounted in a rack or cabinet with other static relays and test equipment. Immediately upon receipt of a static relay equipment, it should be unpacked and examined for any damage sustained in transit. If injury or damage resulting from rough handling is evident, file a damage claim at once with the transportation company and promptly notify the nearest General Electric Sales Office.

Reasonable care should be exercised in unpacking the equipment. If the equipment is not to be installed immediately, it should be stored indoors in a location that is free from moisture, dust, metallic chips, and severe atmospheric contaminants.

Just prior to final installation the shipping support bolt should be removed from each side of all relay units, to facilitate possible future unit removal for maintenance. These shipping support bolts are approximately 8 inches back from the relay front panel. Static relay equipment, when supplied in swing rack cabinets, should be securely anchored to the floor or to the shipping pallet to prevent the equipment from tipping over when the swing rack is opened.

TEST INSTRUCTIONS

CAUTION

IF THE SLA51A RELAY THAT IS TO BE TESTED IS INSTALLED IN AN EQUIPMENT WHICH HAS ALREADY BEEN CONNECTED TO THE POWER SYSTEM, DISCONNECT THE OUTPUTS IN THE ASSOCIATED TYPE SLAT RELAY FROM THE SYSTEM.

A. GENERAL

The SLA51A relay is supplied from the factory either mounted in a static relay equipment or as a separate unit associated with measuring relays, a Type SSA power supply, and some form of channel equipment. All relay units for a given terminal of static relaying equipment are tested together at the factory, and each unit will have the same summary number stamped on its nameplate.

In general, when a time range is indicated on the internal connection diagram, the timer has been factory set at a mid-range value. Timers should be set for the operating or reset times indicated on the associated overall logic diagram. Where a time range is indicated on the overall logic diagram, the timer should be set for the value recommended for that function in the descriptive writeup accompanying the overall logic diagram. Where a setting depends upon conditions encountered on a specific application, this is so stated and the factors influencing the choice of setting are described. The procedure for checking and setting the timers is described in a later section.

B. OPERATIONAL CHECKS

Operation of the SLA51A unit can be checked by observing the signals at the twenty test points (TP1 to TP20) in the SLA51A, by observing the operation of the associated channel equipment, or by observing the output functions in the associated Type SLAT tripping relay. The test points are located on two test cards in positions T and AT, and are numbered 1 to 20 from top to bottom. TP1 is the reference bus for the logic circuit; TP10 is at +15 VDC. The remaining points are located at various strategic points throughout the logic as shown on the internal connection diagram (Figure 2). Test point voltages can be monitored with a portable high impedance voltmeter, the voltmeter on the test panel of the associated equipment, or an oscilloscope.

C. TEST CARD ADAPTER

The test card adapter provides a convenient means of gaining access to any pin of a particular card. Detailed information on the use of the test adapter card is included in the card instruction book GEK-34158.

D. TIMER ADJUSTMENTS AND TESTS

When the time delay cards are to be adjusted or checked, an oscilloscope that can display two traces simultaneously and that has a calibrated horizontal sweep should be used.

In order to test the time cards it is necessary to remove the card previous to the timer (see Table I) and to place the timer card in a card adapter. The card adapter allows access to the input and output of the timer if they are not brought out on test points. The timer test circuit is shown in Figure 7. Opening the N.C. contact causes the output to step up to +15 VDC after the pickup delay of the timer. To increase the pickup time turn the upper potentiometer on the timer card clockwise; to decrease the time turn it counter-clockwise. Closing the contact causes the timer output to drop out after the reset time delay setting of card. If the timer card is provided with a variable reset delay, it can be adjusted by the lower potentiometer on the timer card (CW increases reset time).

TABLE I

TIME UNDER TEST	POSITION	REMOVE CARD IN POSITION
TL 4/40	E	C
TL 4/0	F	D
TL 25/35	M	L
TL 3/50	S	R

E. OVERALL EQUIPMENT TESTS

After the SLA51A relay and the associated static relay units have been individually calibrated and tested for the desired settings, a series of overall operating circuit checks is advisable.

The elementary, overall logic, and logic description for the specific job will be useful for determining the overall operation of the scheme.

Overall equipment tests can be performed by applying AC current and voltages to the measuring units

as specified in the instruction book for the measuring units and checking that proper outputs are obtained from the associated SLAT when the measuring units operate.

MAINTENANCE

A. PERIODIC TESTS

It should be sufficient to check the outputs produced at test points in the SLA51A when periodic calibration tests are made on the associated measuring units, for example, the phase and ground relays in line relaying scheme. No separate periodic tests on the SLA51A itself should be required.

B. TROUBLE SHOOTING

In any trouble shooting of equipment, it should first be established which unit is functioning incorrectly. The overall logic diagram supplied with the equipment shows the combined logic of the complete equipment and the various test points in each unit. By signal tracing, using the overall logic diagram and the various test points, it should be possible to quickly isolate the trouble.

A test adapter card is supplied with each static relay equipment to supplement the prewired test points on the test cards. Use of the adapter card is described in the card instruction book GEK-34158.

A dual-trace oscilloscope is a valuable aid to detailed trouble shooting, since it can be used to determine phase shift, operate and reset times as well as input and output levels. A portable dual-trace oscilloscope with a calibrated sweep and trigger facility is recommended.

C. SPARE PARTS

To minimize possible outage time, it is recommended that a complete maintenance program should include the stocking of at least one spare card of each type. It is possible to replace damaged or defective components on the printed circuit cards, but great care should be taken in soldering so as not to damage or bridge-over the printed circuit busses, or overheat the semi-conductor components. The repaired area should be recovered with a suitable high-dielectric plastic coating to prevent possible breakdowns across the printed busses due to moisture and dust. The wiring diagrams for the cards in the SLA51A relay are included in the card book GEK-34158.

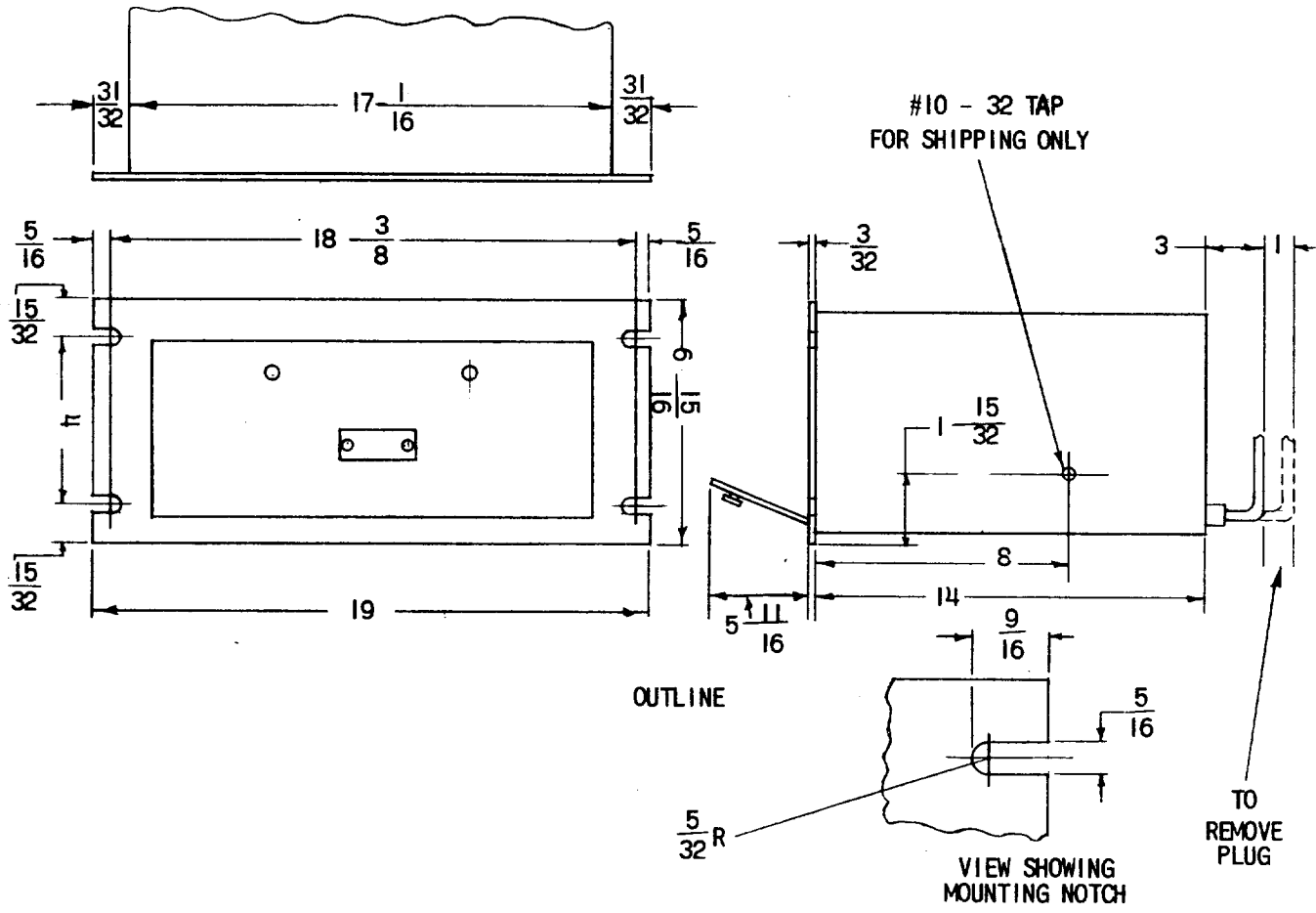
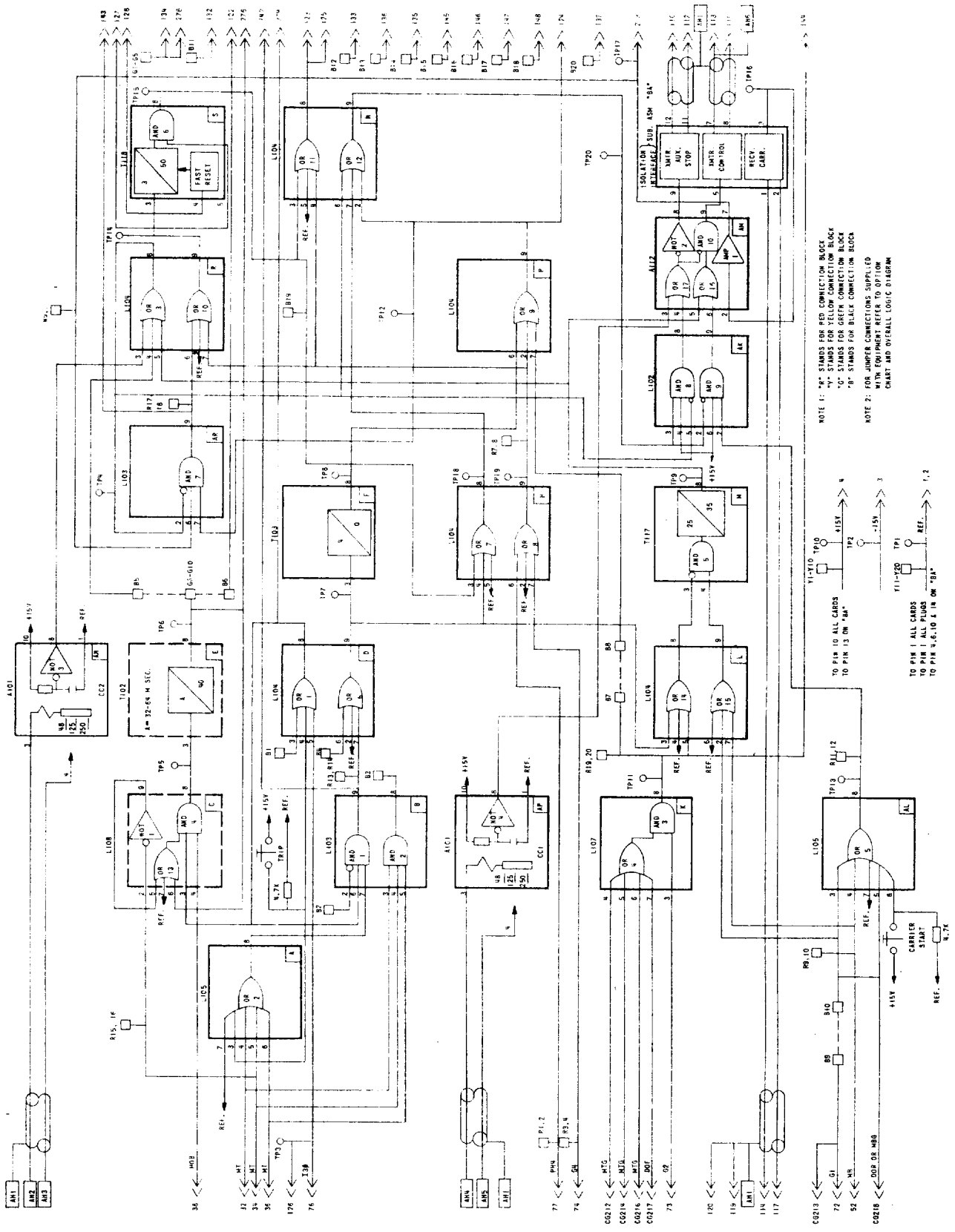

FIG. 1 (0227A2037-0) Outline And Mounting Dimensions For The Type SLA51A Relay



NOTE 1: "G" STANDS FOR GREEN CONNECTION BLOCK
 "Y" STANDS FOR YELLOW CONNECTION BLOCK
 "O" STANDS FOR ORANGE CONNECTION BLOCK
 "B" STANDS FOR BLACK CONNECTION BLOCK

NOTE 2: FOR JUMPER CONNECTIONS SUPPLIED WITH EQUIPMENT REFER TO OPTION CHART AND OVERALL LOGIC DIAGRAM

TO PIN 1 ALL CARDS
 TO PIN 13 ON "8A"

TO PIN 1 ALL CARDS
 TO PIN 1 ALL PLUGS
 TO PIN 4, 6, 10 & 14 ON "8A"

FIG. 2 (0149C7202-5) Internal Connections For The Type SLA51A Relay

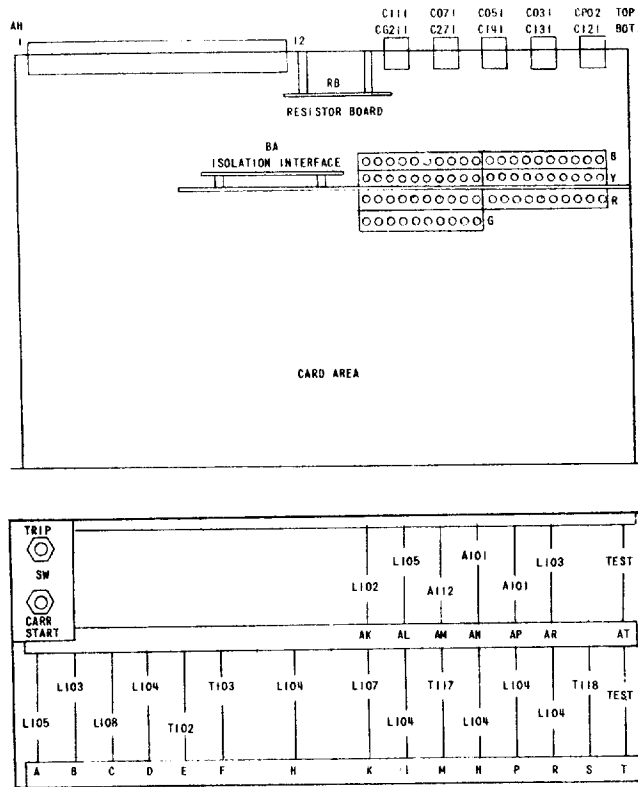

FIG. 3 (0246A6850-0) Component Locations For The Type SLA51A Relay

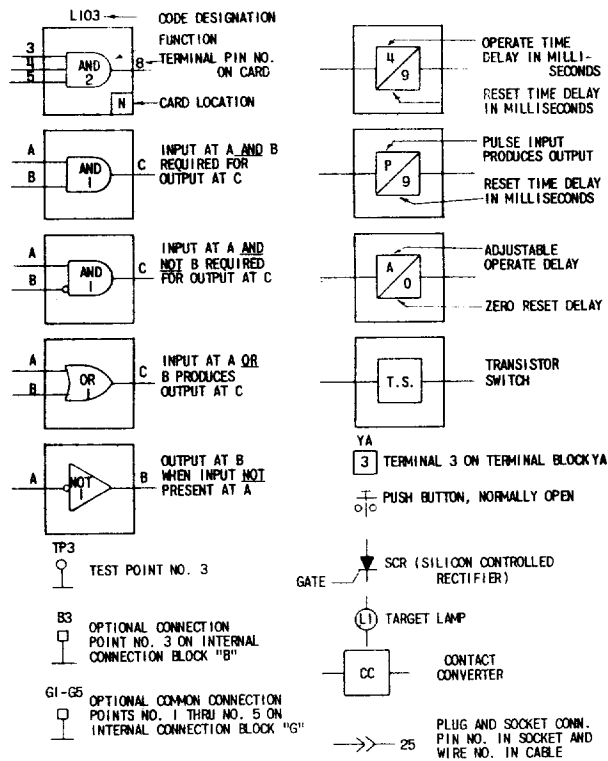

FIG. 4 (0227A2047-0) Logic And Internal Connection Diagram Legend

THE FOLLOWING CONNECTIONS ARE TO BE MADE TO THE MATRIX BLOCKS INSIDE THE SLA LOGIC UNIT.



FROM	TO
B1	Y12
B2	Y11
B4	Y13
B5	Y14
B6	G6
B7	B8
B9	B10
R7	B15
B14	Y15

FROM	TO
411	Y16
412	R1
413	R3
414	R5
415	R13
416	R19
417	R11
418	R17
419	Y19
420	Y20

FIG. 5 (0227A2050-3 SH. 1) Sample Option Chart For The Type SLA51A Relay

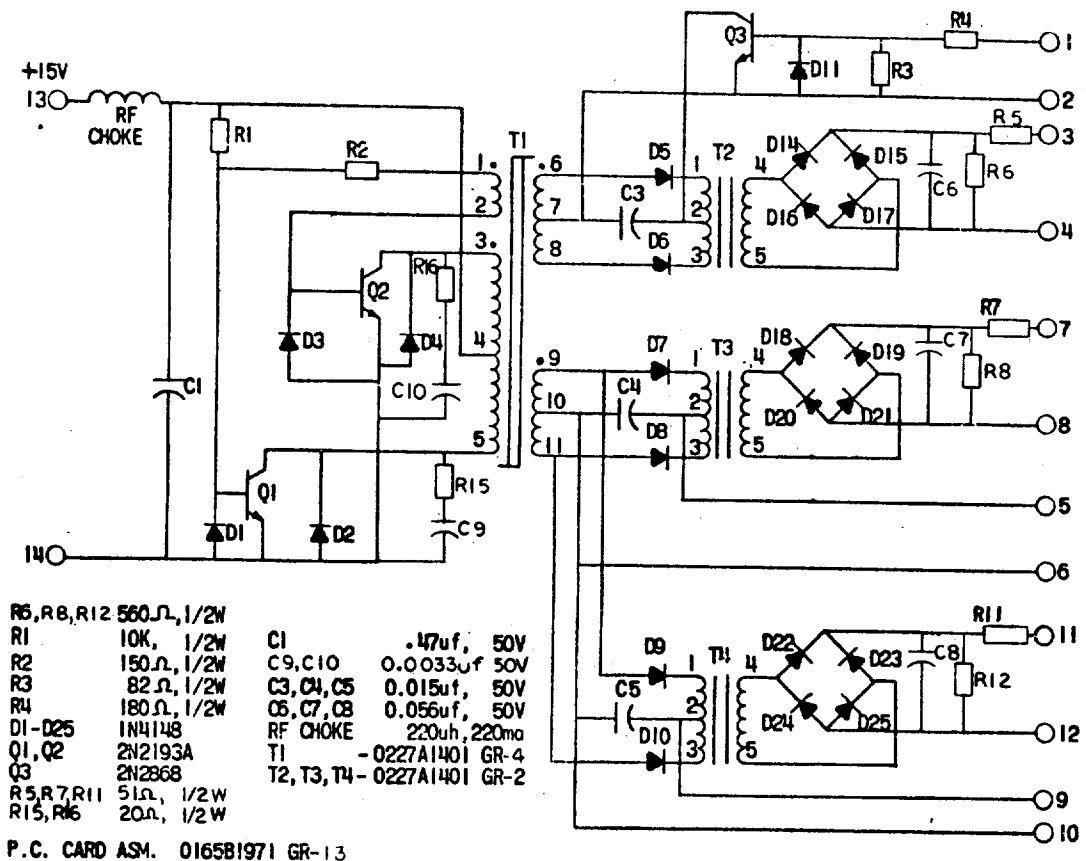
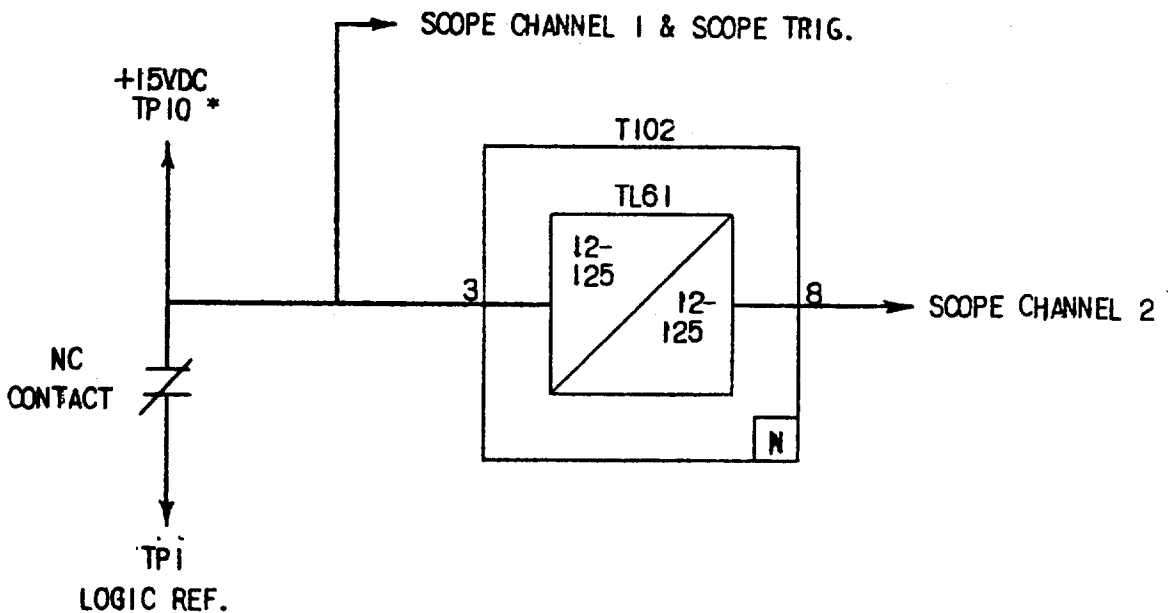

FIG. 6 (0208A5504AJ-1) Isolation Interface Circuit



* THE 15VDC SIGNAL AT PIN 10 HAS A CURRENT LIMITING RESISTOR MOUNTED ON THE TEST CARD.

FIG. 7 (0246A7987-0) Logic Timer Test Circuit