



INSTRUCTIONS

GEK-41994

TYPE SLA54A AUXILIARY
LOGIC RELAY

POWER SYSTEMS MANAGEMENT DEPARTMENT

GENERAL  ELECTRIC

PHILADELPHIA, PA.

C O N T E N T S

DESCRIPTION.....3

APPLICATION.....3

RATINGS.....4

BURDENS.....4

OPERATING PRINCIPLES.....4

 A. LOGIC CIRCUIT.....4

 B. CONTACT CONVERTERS.....4

 C. MONITORING POINTS.....4

 D. CHANNEL INTERFACE.....5

SETTINGS.....5

CONSTRUCTION.....5

RECEIVING, HANDLING & STORAGE.....6

INSTALLATION TESTS.....6

 CAUTION.....6

 A. GENERAL.....6

 B. OPERATIONAL CHECKS.....7

 C. TEST ADAPTER.....7

 D. TIMER ADJUSTMENTS & TEST.....7

 E. OVERALL EQUIPMENT TESTS.....7

MAINTENANCE.....7

 A. PERIODIC TESTS.....7

 B. TROUBLE SHOOTING.....8

 C. SPARE PARTS.....8

DESCRIPTION

The SLA54A relay is an auxiliary logic relay designed to be used in permissive overreaching transferred trip schemes. The relay contains the necessary logic to interpret output signals from associated measuring functions and translate them to an appropriate auxiliary output and tripping relay. In addition to the SLA54A relay, proper phase and ground relays, a power supply, and auxiliary tripping relay are required to complete a particular relaying scheme.

The type SLA54A relay is packaged in a four rack unit enclosed metal case. The relay is suitable for mounting in a 19 inch rack; the outline and mounting dimensions are shown in Figure 1. Internal connections for the SLA54A relay are shown in Figure 2, and the component location drawing is shown in Figure 3.

APPLICATION

The type SLA54A auxiliary logic relay is designed to operate in conjunction with appropriate phase and ground relays and a suitable communication channel to provide a permissive overreaching transferred tripping scheme for transmission line protection. For complete information on this scheme refer to the overall logic diagram and the accompanying logic description in which this relay is used.

Protection features required in a relay scheme often vary with the particular application. It is sometimes desirable to initially provide certain features in a relaying scheme and simultaneously to make provisions for adding or changing features should it later become necessary. To this end this relay design has incorporated circuit flexibility to permit implementation of certain optional features. To implement these features the relay is equipped with matrix connection blocks designated R, Y, G, B, and V. Appropriate jumper connections are made between the various points to modify the logic. The specific optional features available in this relay are as follows:

1. The choice of out-of-step blocking of either tripping or reclosing; matrix points G6, B5 and B6 are provided.
2. Overcurrent supervision of phase MT functions may be bypassed by using matrix point B7 connected to (+) at matrix point Y1.
3. The addition of I_W and I_{OW} overcurrent detectors for weak source terminal applications uses matrix points B1 to R1 and B2 to R3.
4. Inclusion of PH4 phase and/or G4 direct trip overcurrent functions uses matrix point connections B3 to R5 or B4 to R7 respectively.

Various points in the logic can be monitored by connecting jumpers from the cable plug 411-420 to the selected matrix points. This option is further described under the heading "Data Monitoring Points" in the section headed OPERATING PRINCIPLES.

For the specific options and the logic arrangement supplied for a particular relaying scheme refer to the logic diagram and the logic description supplied with that scheme. If it is desired to make logic changes, the diagrams and instruction books supplied with the equipment should be studied to determine the means for implementing the changes. If further assistance is required, contact the nearest General Electric District Sales Office.

There are no measuring functions to be set in this relay but there are certain timers included that must be set in accordance with the demands of the particular protection scheme being employed and the power system on which it is being used. Refer to the section of this book headed SETTINGS for a description of these timers and for suggestions to be used in making appropriate settings.

These instructions do not purport to cover all details or variations in equipment nor to provide for every possible contingency to be met in connection with installation, operation or maintenance. Should further information be desired or should particular problems arise which are not covered sufficiently for the purchaser's purposes, the matter should be referred to the General Electric Company.

RATINGS

The Type SLA54A relay is designed for use in an environment where the air temperature outside the relay case does not exceed -20°C or +65°C.

The Type SLA54A relay requires +15 VDC power source which can be obtained from a Type SSA power supply.

Each contact converter in this relay has a link for selecting the proper voltage for the coil circuit on the contact converter. The three possible voltages are 48 VDC, 125 VDC and 250 VDC.

BURDENS

The SLA54A relay presents a burden of 220 ma to the +15 VDC supply of the Type SSA power supply.

Each contact converter, when energized, will draw approximately 10 ma. from the station battery, regardless of tap setting.

OPERATING PRINCIPLESA. LOGIC CIRCUIT

The functions of the Type SLA54A relay involve basic logic (AND, OR, AND NOT) where the presence or absence of signals, rather than their magnitude, controls the operation. Signals are measured with respect to a reference bus accessible at TP1. In general, a signal below 1 VDC represents an OFF or LOGIC ZERO condition; an ON or LOGIC ONE condition is represented by a signal of approximately +15 VDC.

The symbols used on the internal connection diagram (Figure 2) are explained by the legend shown in Figure 4.

The matrix block options shown in the internal connections of the SLA54A relay are connected at the factory. The connections are shown on the associated overall logic and are listed on the associated option chart. A sample option chart for the Type SLA54A relay is shown in Figure 5.

B. CONTACT CONVERTERS

Three contact converters are provided in the SLA54A relay. Their functions are as follows:

- CC1 - Provides a means of keying the tone transmitter from an external contact. This is frequently used in conjunction with breaker failure schemes.
- CC2 - To block pilot relay tripping upon closure of an external contact. This is usually used in connection with the channel cut off or channel test functions in the equipment.
- CC3 - Provides a means of keying the tone channel to TRIP by means of the breaker "b" auxiliary switch when the breaker is open. This will provide the remote terminal relays with a permissive signal so as to accomplish tripping if a fault should occur while the one breaker is open. It will also provide for primary relay tripping when energizing a faulted line.

C. MONITORING POINTS

Various points within the relay logic are brought out to a cable plug mounted on the back of the SLA54A relay. This plug provides nine monitoring points plus one point for a voltage reference. Specific points that have been preselected are shown on the logic diagram marked with a number series of 411 to 420. These points may be augmented or readily changed at the matrix boards located inside the SLA relay. To monitor these points, an additional piece of equipment called a Data Logging Amplifier, DLA, is required. The outputs of the DLA are normally fed into an oscillograph which is automatically started upon the occurrence of a system disturbance. A typical selection of monitoring points is as follows:

- 413 - G4 Output
- 414 - Trip signal received
- 415 - Transmitter keying input

- 416 - Trip bus
- 417 - Ground relay trip
- 418 - Phase relay trip
- 419 - Compares output
- 420 - Out-of-step condition

D. CHANNEL INTERFACE

The logic of the Type SLA54A relay includes an isolation interface (Figure 6) between the relays in the scheme and the associated channel. The circuitry of the isolation interface provides a signal path but maintains metallic isolation. This feature makes it possible to maintain isolation between the DC supply used for the relays and that employed by the channel.

When pins 9 and 10 are both connected to relay reference, a metallicly separate positive logic signal appears at pin 11 with respect to 12. The output from the isolation interface is a 5 VDC, 20 ma. signal.

SETTINGS

The following timers in the SLA54A relay will probably require adjustment.

A/40 TIMER - The 2.5/16 timer found in the SLY51A and the A/40 timer are part of the out-of-step detection scheme. The 2.5/16 timer forms a "Tomato" (outer) characteristic; thus the distance a swing must travel before the MHO (inner) characteristic is encountered is determined by the pickup setting of this timer. The A/40 timer is used to measure the time of travel between the outer and inner characteristic. An out-of-step condition will be detected when both timers are adjusted properly. The setting of both timers should be based on the results of system swing studies. However, lower pickup settings on the 2.5/16 timer (larger tomato characteristic) in conjunction with short pickup settings on the A/40 timer will enable the out-of-step protection to detect faster swings. The pickup setting of the 2.5/16 timer should not be made so low though that it will operate on load or minor swings.

B/O - C/O - These timers are used to provide the necessary coordination to prevent relay false tripping which might otherwise result from a current reversal occurring during the clearing of a parallel line fault. An analysis of the conditions and the necessary timer settings will be found in the logic description for the particular relay scheme being used. If these timers are not needed, they should be removed and replaced with jumper cards.

D/D - The D/D timer is used to coordinate the operation of the circuit breaker "b" switch with the operation of the main poles of the breaker for keying the channel transmitter. Refer to the analysis of these conditions and the suggested timer settings discussed in the logic description for the particular relay scheme being used.

3/50 - The 3/50 timer is the trip integrating timer following the comparer. The 3 ms pickup delays tripping and is arbitrarily chosen to provide a security margin in the scheme against false tripping.

CONSTRUCTION

The SLA54A relay is packaged in an enclosed metal case with hinged front covers and removable top cover. The outline and mounting dimensions of the case and the physical location of the components are shown in Figures 1 and 3 respectively.

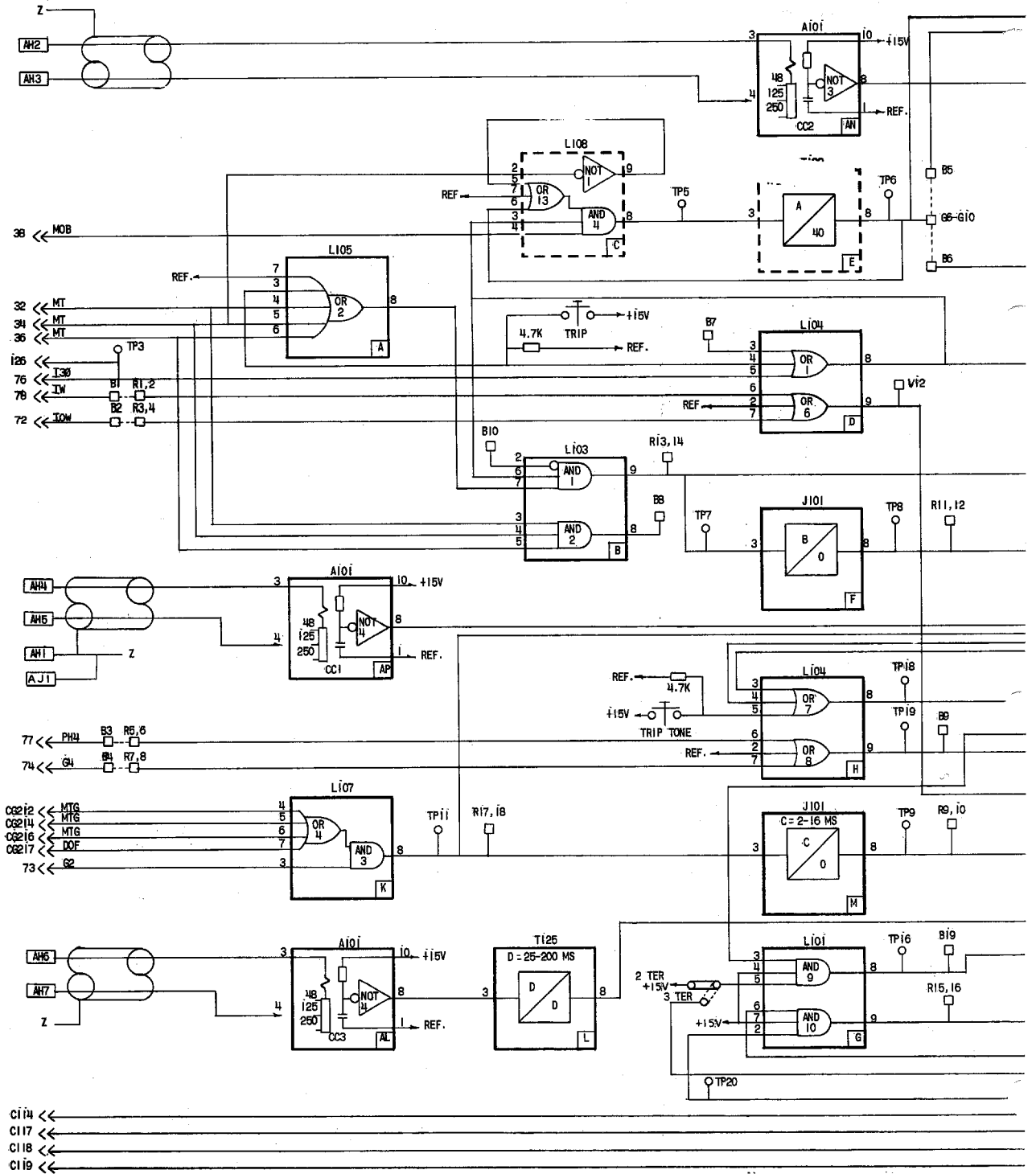

NOTE 1 "R" STANDS FOR RED CONNECTION BK.
 "Y" STANDS FOR YELLOW CONNECTION BK.
 "G" STANDS FOR GREEN CONNECTION BK.
 "B" STANDS FOR BLACK CONNECTION BK.
 NOTE 2 FOR JUMPER CONNECTIONS SUPPLIED WITH EQUIPMENT
 REFER TO OPTION CHART AND OVERALL LOGIC DIAGRAM.

MATRIX BLOCK
 CONNECTION
 PER OVERALL
 LOGIC
 SEE - OPTION
 CHART

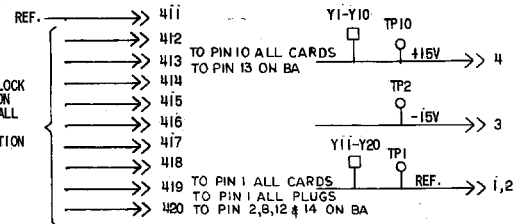
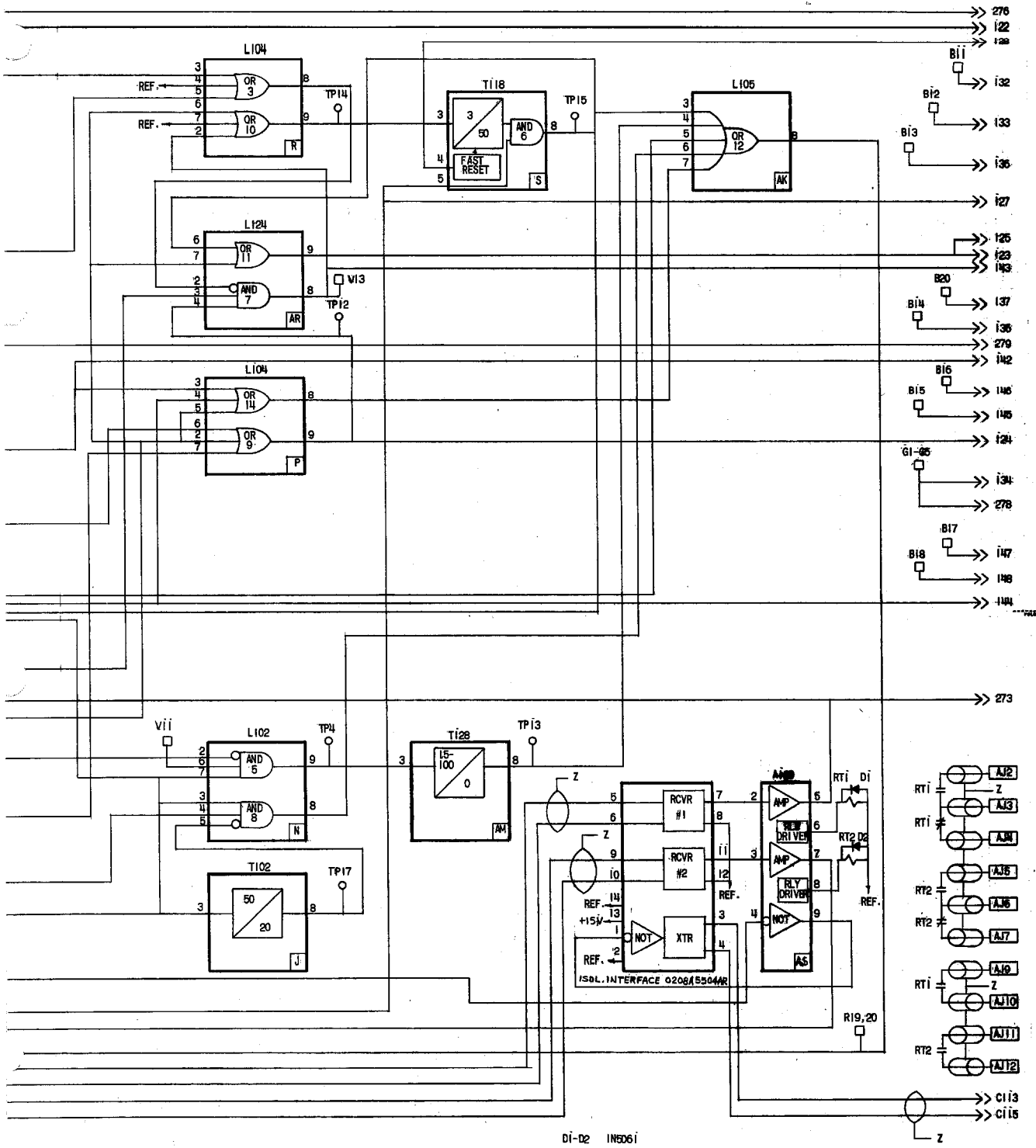

Figure 2 (0121D9491-0)



DI-D2 IN501

SLA54A FORM NO.	CARD POSITION		
	C	E	
I	X	X	

Connections for the Type SLA54A Relay

The SLA54A relay contains printed circuit cards identified by a code number such as A111, T102, L104 where A designates auxiliary function, T designates time delay function, and L designates logic function. The printed circuit cards plug in from the front of the unit. The sockets are marked with letter designations or "addresses" (D, E, F, etc.) which appear on the guide strips in front of each socket, on the component location drawing, on the internal connection diagram and on the printed circuit card. The test points (TP1, TP2, etc.) shown on the internal connection diagram are connected to instrument jacks on a test card in position T or AT with TP1 at the top of the AT card. *TP10 is tied to +15 VDC through a 1.5K resistor. This resistor limits the current when TP10 is used to supply a logic signal to a card.

Other logic options are selected by means of taper tip jumpers and matrix blocks. These matrix blocks are located inside of the unit as shown in Figure 3. The green (G) matrix block has ten points in two 5 point common groups. The black (B) matrix block has 20 individual matrix points which are grouped in pairs. The yellow (Y) block has 20 points which are grouped in 10 common points: 1 to 10 are tied to +15 VDC; 11 to 20 are tied to reference. The violet (V) block has 20 individual points identical to the black (B) block. A tool for inserting and removing the taper tip jumpers is supplied with each relay.

RECEIVING, HANDLING AND STORAGE

These relays will normally be supplied as a part of a static relay equipment, mounted in a rack or cabinet with other static relays and test equipment. Immediately upon receipt of a static relay equipment, it should be unpacked and examined for any damage sustained in transit. If injury or damage resulting from rough handling is evident, file a damage claim at once with the transportation company and promptly notify the nearest General Electric Sales Office.

Reasonable care should be exercised in unpacking the equipment. If the equipment is not to be installed immediately, it should be stored indoors in a location that is free from moisture, dust, metallic chips, and severe atmospheric contaminants.

Just prior to final installation the shipping support bolt should be removed from each side of all relay units, to facilitate possible future unit removal for maintenance. These shipping support bolts are approximately 8 inches back from the relay front panel. Static relay equipment, when supplied in swing rack cabinets, should be securely anchored to the floor or to the shipping pallet to prevent the equipment from tipping over when the swing rack is opened.

INSTALLATION TESTS

CAUTION

THE LOGIC SYSTEM SIDE OF THE DC POWER SUPPLY USED WITH MOD III STATIC RELAY EQUIPMENT IS ISOLATED FROM GROUND. IT IS A DESIGN CHARACTERISTIC OF MOST ELECTRONIC INSTRUMENTS THAT ONE OF THE SIGNAL INPUT TERMINALS IS CONNECTED TO INSTRUMENT CHASSIS. IF THE INSTRUMENT USED TO TEST THE RELAY EQUIPMENT IS ISOLATED FROM GROUND, ITS CHASSIS MAY HAVE AN ELECTRICAL POTENTIAL WITH RESPECT TO GROUND. THE USE OF A TEST INSTRUMENT WITH A GROUNDED CHASSIS WILL NOT AFFECT THE TESTING OF THE EQUIPMENT. HOWEVER, A SECOND GROUND CONNECTION TO THE EQUIPMENT, SUCH AS A TEST LEAD INADVERTENTLY DROPPING AGAINST THE RELAY CASE, MAY CAUSE DAMAGE TO THE LOGIC CIRCUITRY. NO EXTERNAL TEST EQUIPMENT SHOULD BE LEFT CONNECTED TO THE STATIC RELAYS WHEN THEY ARE IN PROTECTIVE SERVICE, SINCE TEST EQUIPMENT GROUNDING REDUCES THE EFFECTIVENESS OF THE ISOLATION PROVIDED.

A. GENERAL

The SLA54A relay is supplied from the factory either mounted in a static relay equipment or as a separate unit associated with measuring relays, a Type SSA power supply, and some form of channel equipment. All relay units for a given terminal of static relaying equipment are tested together at the factory, and each unit will have the same summary number stamped on its nameplate.

In general, when a time range is indicated on the internal connection diagram, the timer has been factory set at a mid-range value. Timers should be set for the operating or reset times indicated on the associated overall logic diagram. When a time range is indicated on the overall logic diagram, the timer should be set for the value recommended for that function in the descriptive writeup accompanying the overall logic diagram. Where a setting depends upon conditions encountered on a specific application, this is so stated and the factors influencing the choice of setting are described. The procedure for checking and setting the timers is described in a later section.

B. OPERATIONAL CHECKS

Operation of the SLA54A unit can be checked by observing the signals at the twenty test points (TP1 to TP20) in the unit, by observing the operation of the associated channel equipment, or by observing the output functions in the associated Type SLAT tripping relay. The test points are located on two test cards in positions T and AT, and are numbered 1 to 20 from top to bottom. TP1 is the reference bus for the logic circuit; TP10 is at +15 VDC. The remaining points are located at various strategic points throughout the logic as shown on the internal connection diagram (Figure 2). Test point voltages can be monitored with a portable high impedance voltmeter, the voltmeter on the test panel of the associated equipment, or an oscilloscope.

C. TEST ADAPTER

The test card adapter provides a convenient means of gaining access to any pin of a particular card. Detailed information on the use of the test adapter card is included in the card instruction book GEK-34158.

D. TIMER ADJUSTMENTS AND TESTS

When the time delay cards are to be adjusted or checked, an oscilloscope that can display two traces simultaneously and that has a calibrated horizontal sweep should be used.

In order to test the time cards it is necessary to remove the card previous to the timer (see Table I) and to place the timer card in a card adapter. The card adapter allows access to the input and output of the timer if they are not brought out on test points. The timer test circuit is shown in Figure 1. Opening the N.C. contact causes the output to step up to +15 VDC after the pickup delay of the timer. To increase the pickup time turn the upper potentiometer on the timer card clockwise; to decrease the time turn it counter-clockwise. Closing the contact causes the timer output to drop out after the reset time delay setting of card. If the timer card is provided with a variable reset delay, it can be adjusted by the lower potentiometer on the timer card (CW increases reset time).

TABLE I

TIME UNDER TEST	POSITION	REMOVE CARD IN POSITION
TL /40	E	C
TL 4/0	F	D
TL 25/35	M	L
TL 3/50	S	R

E. OVERALL EQUIPMENT TESTS

After the SLA54A relay and the associated static relay units have been individually calibrated and tested for the desired settings, a series of overall operating circuit checks is advisable.

The elementary, overall logic, and logic description for the specific job will be useful for determining the overall operation of the scheme.

Overall equipment tests can be performed by applying AC current and voltages to the measuring units as specified in the instruction book for the measuring units and checking that proper outputs are obtained from the associated SLAT when the measuring units operate.

MAINTENANCE

A. PERIODIC TESTS

It should be sufficient to check the outputs produced at test points in the SLA54A when periodic calibration tests are made on the associated measuring units, for example, the phase and ground relays in line relaying scheme. No separate periodic tests on the SLA54A itself should be required.

B. TROUBLE SHOOTING

In any trouble shooting of a equipment, it should first be established which unit is functioning incorrectly. The overall logic diagram supplied with the equipment shows the combined logic of the complete equipment and the various test points in each unit. By signal tracing, using the overall logic diagram and the various test points, it should be possible to quickly isolate the trouble.

A test adapter card is supplied with each static relay equipment to supplement the prewired test points on the test cards. Use of the adapter card is described in the card instruction book GEK-34158.

A dual-trace oscilloscope is a valuable aid to detailed trouble shooting, since it can be used to determine phase shift, operate and reset times as well as input and output levels. A portable dual-trace oscilloscope with a calibrated sweep and trigger facility is recommended.

C. SPARE PARTS

To minimize possible outage time, it is recommended that a complete maintenance program should include the stocking of at least one spare card of each type. It is possible to replace damaged or defective components on the printed circuit cards, but great care should be taken in soldering so as not to damage or bridge-over the printed circuit busses, or overheat the semiconductor components. The repaired area should be recovered with a suitable high-dielectric plastic coating to prevent possible breakdowns across the printed busses due to moisture and dust. The wiring diagrams for the cards in the SLA54A relay are included in the card book GEK-34158.

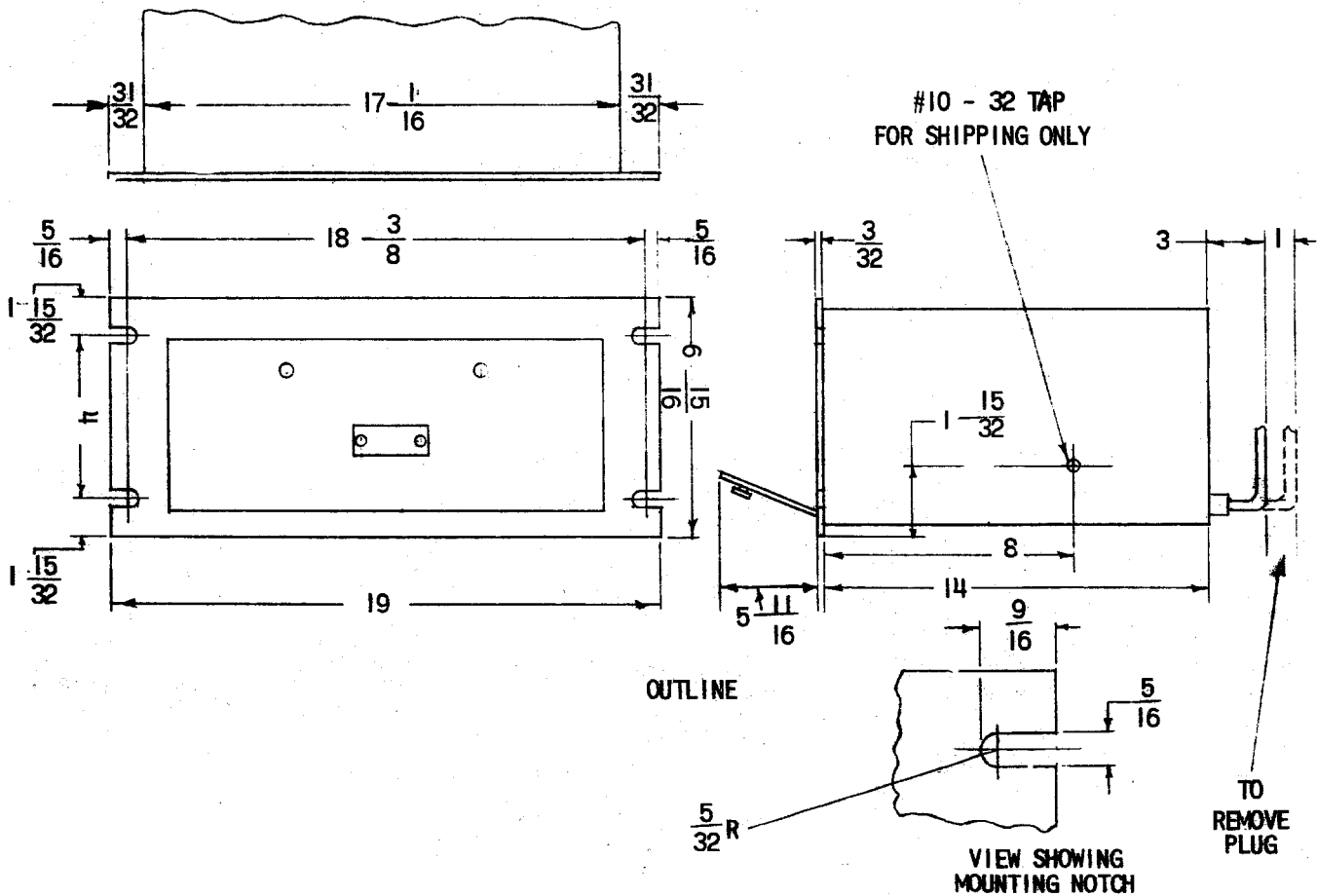

Figure 1 (0227A2037-0) Outline and Mounting Dimensions for the Type SLA54A Relay

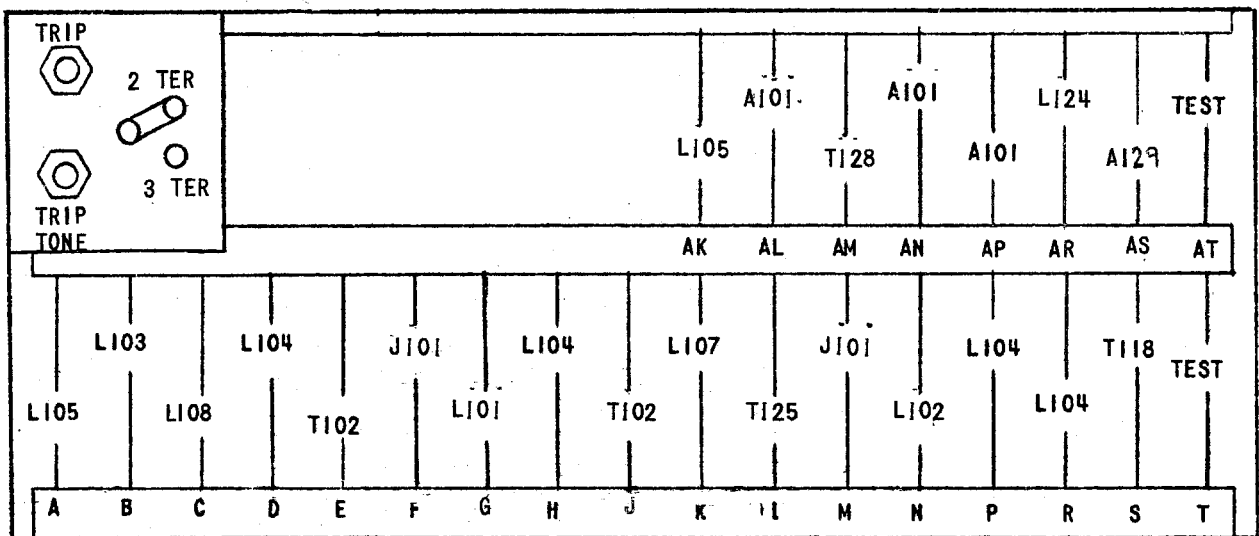
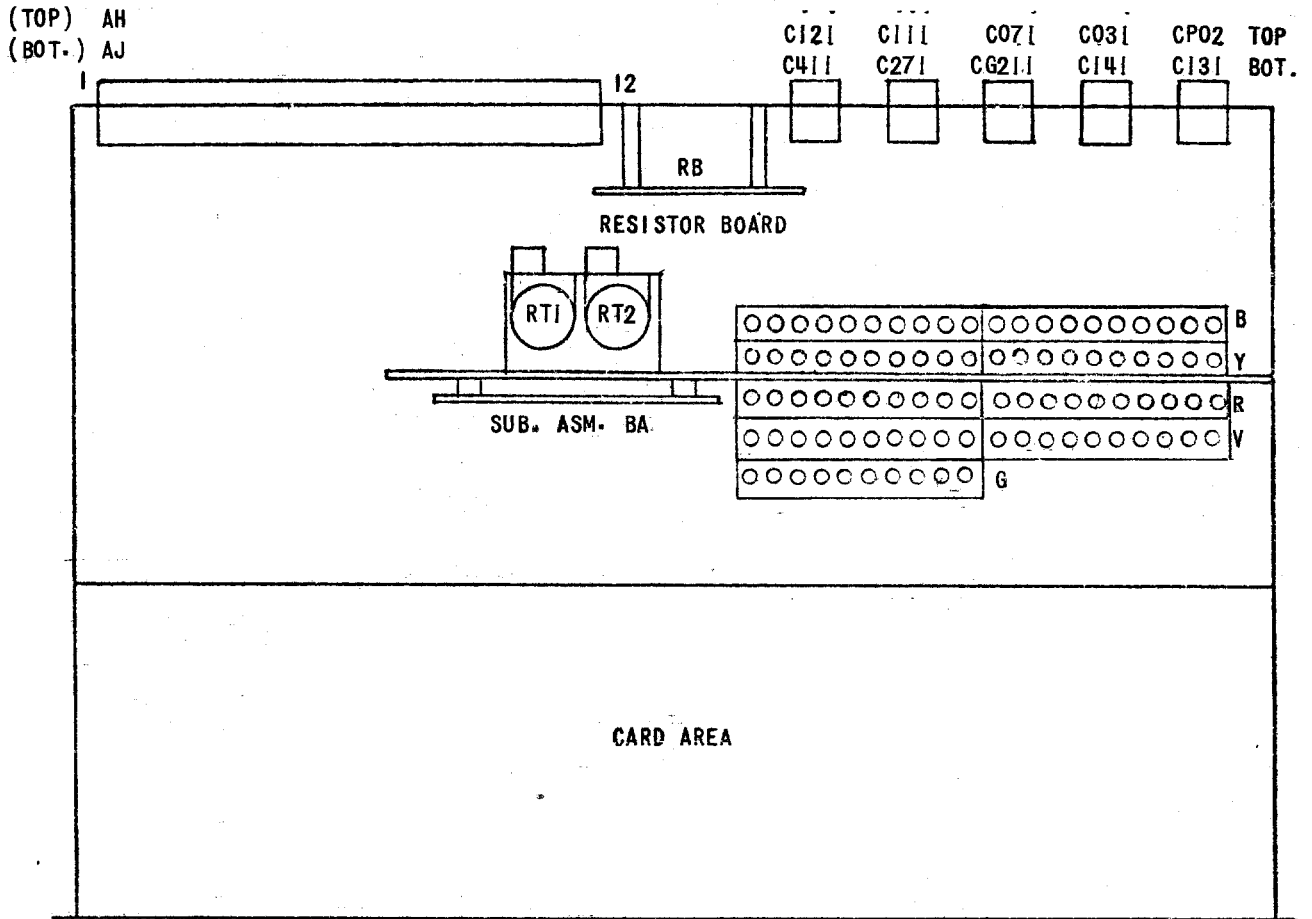

Figure 3 (0257A5725-0) Component Locations for the Type SLA54A Relay

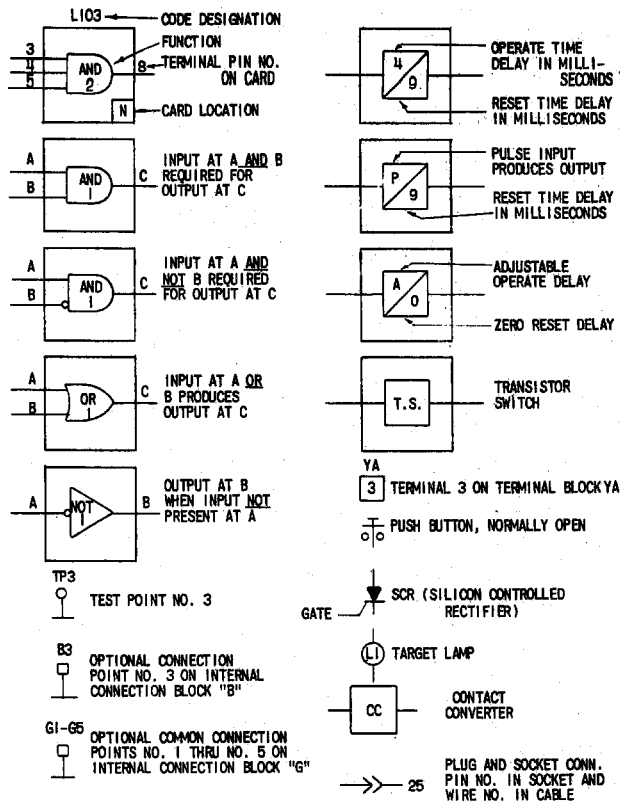

Figure 4 (0227A2047-0) Logic and Internal Connection Diagram Legend

THE FOLLOWING CONNECTIONS ARE TO BE MADE TO THE TERMINAL BLOCKS IN THE REAR OF THE SLA LOGIC UNIT 28

FROM	TO	FROM	TO	FROM	TO
PL412	V12	B1	R1		
413	R8	B2	R3		
414	B19	B4	R7		
415	R15	B9	B15		
416	G5	B7	Y11		
417	R9	B10	Y12		
418	R11	V11	Y1		
419	V13	R5	Y13		
420	G7	B5	Y14		
		B6	Y15		
		B14	Y16		

Figure 5 (0227A2050-1 Sh. 28) Sample Option Chart for the Type SLA54A Relay