



**INSTRUCTIONS**

**GEK-45412A**

*SUPERSEDES GEK-45412*

**AUXILIARY LOGIC UNIT**

**TYPE SLA52E**

---

**GENERAL  ELECTRIC**

TABLE OF CONTENTS

DESCRIPTION-----3  
 APPLICATION AND SETTINGS-----3  
 RATINGS-----3  
 BURDENS-----3  
 OPERATING PRINCIPLES-----3  
 CONSTRUCTION-----4  
 INSTALLATION TESTS-----4  
     CAUTION-----7  
     GENERAL-----7  
     OPERATIONAL CHECKS-----7  
     TEST CARD ADAPTER-----7  
     TIMER ADJUSTMENTS AND TESTS-----7  
     OVERALL EQUIPMENT TESTS-----7  
 MAINTENANCE-----8  
     PERIODIC TESTS-----8  
     TROUBLE SHOOTING-----8  
     SPARE PARTS-----8

AUXILIARY LOGIC UNITTYPE SLA52EDESCRIPTION

The SLA52E unit is an auxiliary logic unit in blocking or unblocking schemes using frequency shift channel equipment. It is usually used with a type SLYP positive sequence distance unit a type SLCW negative sequence directional overcurrent unit, a type SLAT output tripping unit, a type SSA power supply, and a test panel.

The SLA52E has appropriate interconnections for use with a type SLAT54B auxiliary and tripping unit when applied in single pole tripping and reclosing schemes.

The SLA52E is designed with considerable flexibility to accommodate various types of schemes such as blocking, unblocking, permissive transfer tripping, or combined schemes such as an unblocking scheme combined with a direct transfer trip scheme. Provision is made for various auxiliary tripping circuits which may be supplied initially or easily added later in the field. These optional circuits include direct tripping overcurrent and distance functions, line "pickup" circuitry, "weak infeed" trip circuitry, out-of-step tripping or blocking circuitry, and second zone backup timing circuitry.

APPLICATION AND SETTINGS

Because of the flexibility of the type SLA52E, the application and settings will vary with the particular type of scheme in which it is used. Refer to the overall logic diagram description for application and setting information for the particular scheme in which the SLA52E is used.

RATINGS

The Type SLA52E relay is designed for use in an environment where the ambient temperature outside the relay case is between  $-20^{\circ}\text{C}$  and  $+65^{\circ}\text{C}$ .

The Type SLA52E relay requires a  $\pm 15\text{VDC}$  power source which can be obtained from a type SSA50/51 power supply.

Each contact converter in this relay has a link for selecting the proper voltage for the coil circuit of the contact converter. The three available voltage taps are for 48, 125 or 250 VDC.

BURDENS

The SLA52E presents a burden of 350 milliamperes to the +15 VDC supply of the Type SSA power supply.

Each contact converter, when energized, will draw approximately 10 milliamperes from the station battery, regardless of the station battery voltage.

OPERATING PRINCIPLES

The functions included in the Type SLA52E relay involve basic logical operations (AND, OR, NOT) where the presence or absence of signals, rather than their magnitude, controls the operation. Signals are measured with respect to a reference bus accessible at TP1. In general, a signal below one VDC represents an OFF or LOGIC ZERO condition; an ON or LOGIC ONE condition is represented by a signal of approximately +15 VDC.

The symbols used on the internal connection diagram Figure 1 are explained by the legend shown in Figure 2.

The matrix blocks shown on the internal connections diagram of the SLA52E are connected by jumpers at the factory. These connections are used to implement the logic arrangement shown on the associated overall

*These instructions do not purport to cover all details or variations in equipment nor to provide for every possible contingency to be met in connection with installation, operation or maintenance. Should further information be desired or should particular problems arise which are not covered sufficiently for the purchaser's purposes, the matter should be referred to the General Electric Company.*

*To the extent required the products described herein meet applicable ANSI, IEEE and NEMA standards; but no such assurance is given with respect to local codes and ordinances because they vary greatly.*

logic diagram. These matrix jumpers are listed on the associated option chart. A typical option chart for the Type SLA52E relay is shown in Figure 3. Some of the matrix block connections may be customer options. These connections will then be shown as optional connections on the overall logic and must be selected by the user before the unit is placed in service.

The purpose of the contact converters (CC1, CC2, CC3) included in the Type SLA52E relay is to convert a contact operation into a signal that is compatible with the logic circuitry of the relay. When the external contact is closed a +15VDC signal is produced by the contact converter. The function of each contact converter depends upon the particular relaying scheme in which it is employed.

The Type SLA52E relay has provisions for up to 18 outputs suitable for driving a Type DLA data logging amplifier unit. Any matrix block point which is not used as a logic connection may be monitored by connecting a lead from the 411 or 421 socket to the block. If it is desired to monitor a matrix point which is used as a logic connection, wires 417 to 420 and 427 to 430 may be used. These points have two leads with taper tips which are used to replace the logic jumper. This provides the logic signal path and also a signal for the DLA unit. Any factory selected DLA points are listed on the option chart.

The Type SLA52E relay includes an isolation interface between the relaying equipment and the associated channel. The internal connections of the interface card are shown in Figure 4. The circuitry of the isolation interface provides a signal path, but maintains metallic isolation. This feature makes it possible to maintain isolation between the DC power supply used for the relays and that employed by the channel.

#### CONSTRUCTION

The SLA52E relay is packaged in an enclosed metal case with hinged front covers and removable top cover. The outline and mounting dimensions of the case and the physical location of the components are shown in Figures 5 and 6 respectively.

The SLA52E relay contains printed circuit cards identified by a code number such as A111, T102, L104 where A designates auxiliary function, T designates time delay function, and L designates logic function. The printed circuit cards plug in from the front of the unit. The sockets are marked with letter designations or "addresses" (D,E,F,etc.) which appear on the guide strips in front of each socket, on the component location drawing, on the internal connection diagram and on the printed circuit card. The test points (TP1, TP2, etc.) shown in the internal connection diagram are connected to instrument jacks on a test card in position T or AT with TP1 at the top of the AT card. TP10 is tied to +15 VDC through a 1.5K resistor. This resistor limits the current when TP10 is used to supply a logic signal.

Logic options in the SLA52E relay are selectable by means of jumper wires with taper tip pins on each end which are used to interconnect the matrix block points. These matrix blocks are located in the rear of the unit as shown in Figure 6. The top cover of the relay must be removed to make the blocks accessible. The taper tip jumpers should be inserted and removed using the special tools which are supplied with each equipment. The green (G), black (B), white (W), violet (V), orange (O) and brown (BR) matrix blocks have 20 individual matrix points. The red (R) block has 20 points which are grouped in 10 pairs. The yellow (Y) block has 20 points, which are grouped in 2 sets of 10 common points; Y1 to Y10 are connected to +15 VDC, Y11 to Y20 are connected to reference.

These relays will normally be supplied as a part of a static relay equipment, mounted in a rack or cabinet with other static relays and test equipment. Immediately upon receipt of a static relay equipment, it should be unpacked and examined for any damage sustained in transit. If injury or damage resulting from rough handling is evident, file a damage claim at once with the transportation company and promptly notify the nearest General Electric Sales Office.

Reasonable care should be exercised in unpacking the equipment. If the equipment is not to be installed immediately, it should be stored indoors in a location that is free from moisture, dust, metallic chips, and severe atmospheric contaminants.

Just prior to final installation the shipping support bolt should be removed from each side of all relay units, to facilitate possible future unit removal for maintenance. These shipping support bolts are approximately 8 inches back from the relay front panel. Static relay equipment, when supplied in swing rack cabinets, should be securely anchored to the floor or to the shipping pallet to prevent the equipment from tipping over when the swing rack is opened.

#### INSTALLATION TESTS

If the SLA52E relay that is to be tested is installed in an equipment which has already been connected to the power system, disconnect the outputs in the associated Type SLAT relay from the system.

CAUTION

THE LOGIC SYSTEM SIDE OF THE DC POWER SUPPLY USED WITH MOD III STATIC RELAY EQUIPMENT IS ISOLATED FROM GROUND. IT IS A DESIGN CHARACTERISTIC OF MOST ELECTRONIC INSTRUMENTS THAT ONE OF THE SIGNAL INPUT TERMINALS IS CONNECTED TO INSTRUMENT CHASSIS. IF THE INSTRUMENT USED TO TEST THE RELAY EQUIPMENT IS ISOLATED FROM GROUND, ITS CHASSIS MAY HAVE AN ELECTRICAL POTENTIAL WITH RESPECT TO GROUND. THE USE OF A TEST INSTRUMENT WITH A GROUNDED CHASSIS WILL NOT AFFECT THE TESTING OF THE EQUIPMENT. A SECOND GROUND CONNECTION TO THE EQUIPMENT, SUCH AS A TEST LEAD INADVERTENTLY DROPPING AGAINST THE RELAY CASE, MAY CAUSE DAMAGE TO THE LOGIC CIRCUITRY. NO EXTERNAL TEST EQUIPMENT SHOULD BE LEFT CONNECTED TO THE STATIC RELAYS WHEN THEY ARE IN PROTECTIVE SERVICE, SINCE TEST EQUIPMENT GROUNDING REDUCES THE EFFECTIVENESS OF THE ISOLATION PROVIDED.

GENERAL

The SLA52E relay is supplied from the factory either mounted in a static relay equipment or as a separate unit associated with measuring relays, a Type SSA power supply, and some form of channel equipment. All relay units for a given terminal of static relaying equipment are tested together at the factory, and each unit will have the same summary number stamped on its nameplate.

Timers should be set for the operating and reset times indicated on the associated overall logic diagram. Where a time range is indicated on the overall logic diagram, the timer should be set for the value recommended for that function in the descriptive writeup accompanying the overall logic diagram. Where a setting depends upon conditions encountered on a specific application, this is so stated and the factors influencing the choice of setting are described. The procedure for checking and setting the timers is described in a later section.

OPERATIONAL CHECKS

Operation of the SLA52E unit can be checked by observing the signals at the twenty test points (TP1 to TP20) in the SLA52E by observing the operation of the associated channel equipment, or by observing the output functions in the associated Type SLAT tripping relay. The test points are located on two test cards in positions T and AT, and are numbered 1 to 20 from top to bottom. TP1 is the reference bus for the logic circuit; TP10 is at +15 VDC. The remaining points are located at various strategic points throughout the logic as shown on the internal connection diagram Figure 1. Test point voltages can be monitored with a portable high impedance voltmeter, the voltmeter on the test panel of the associated equipment, or an oscilloscope.

Operation of any logic function may be checked by supplying the correct inputs to the card. This is accomplished by placing the card under test in a card extender, removing the cards which normally supply the input signals, and then connecting the card inputs to either TP10 or TP1. An output should be produced when the proper combination of inputs is supplied.

TEST CARD ADAPTER

The test card adapter provides a convenient means of gaining access to any pin of a particular card. Detailed information on the use of the test adapter card is included in the card instruction book GEK-34158.

TIMER ADJUSTMENTS AND TESTS

When the time delay cards are to be adjusted or checked, an oscilloscope that can display two traces simultaneously and that has a calibrated horizontal sweep should be used.

In order to test the timer cards it is necessary to remove the card which supplies the input to the timer and to place the timer card in a card adapter. The card adapter allows access to the input and output of the timer if they are not brought out on test points. The timer test circuit is shown in Figure 7. Opening the N.C. contact causes the output to step up to +15 VDC after the pickup delay of the timer. To increase the pickup time turn the upper potentiometer on the timer card clockwise; to decrease the time delay setting of card. If the timer card is provided with a variable reset delay, it can be adjusted by the lower potentiometer on the timer card (CW increases reset time).

OVERALL EQUIPMENT TESTS

After the SLA52E relay and the associated static relay units have been individually calibrated and tested for the desired settings, a series of overall operating circuit checks is advisable.

The elementary, overall logic, and logic description for the specific job will be useful for

determining the overall operation of the scheme.

Overall equipment tests can be performed by applying AC current and voltages to the measuring units as specific in the instruction book for the measuring units and checking that proper outputs are obtained from the associated SLAT when the measuring units operate.

## MAINTENANCE

### PERIODIC TESTS

It should be sufficient to check the outputs produced at test points in the SLA52E when periodic calibration tests are made on the associated measuring units, for example the phase and ground relay in line relaying scheme. No separate periodic tests on the SLA52E itself should be required.

### TROUBLE SHOOTING

In any trouble shooting of equipment, it should first be established which unit is functioning incorrectly. The overall logic diagram supplied with the equipment shows the combined logic of the complete equipment and the various test points in each unit. By signal tracing, using the overall logic diagram and the various test points, it should be possible to quickly isolate the trouble.

A test adapter card is supplied with each static relay equipment to supplement the prewired test points on the test cards. Use of the adapter card is described in the card instruction book GEK-34158.

A dual-trace oscilloscope is a valuable aid to detailed trouble shooting, since it can be used to determine phase shift, operate and reset times as well as input and output levels. A portable dual-trace oscilloscope with a calibrated sweep and trigger facility is recommended.

### SPARE PARTS

To minimize possible outage time, it is recommended that a complete maintenance program should include the stocking of at least one spare card of each type. It is possible to replace damaged or defective components on the printed circuit cards, but great care should be taken in soldering so as not to damage or bridge-over the printed circuit buses, or overheat the semi-conductor components. The repaired area should be recovered with a suitable high-dielectric plastic coating to prevent possible breakdowns across the printed buses due to moisture and dust. The wiring diagrams for the cards in the SLA52E relay are included in the card book GEK-34158.

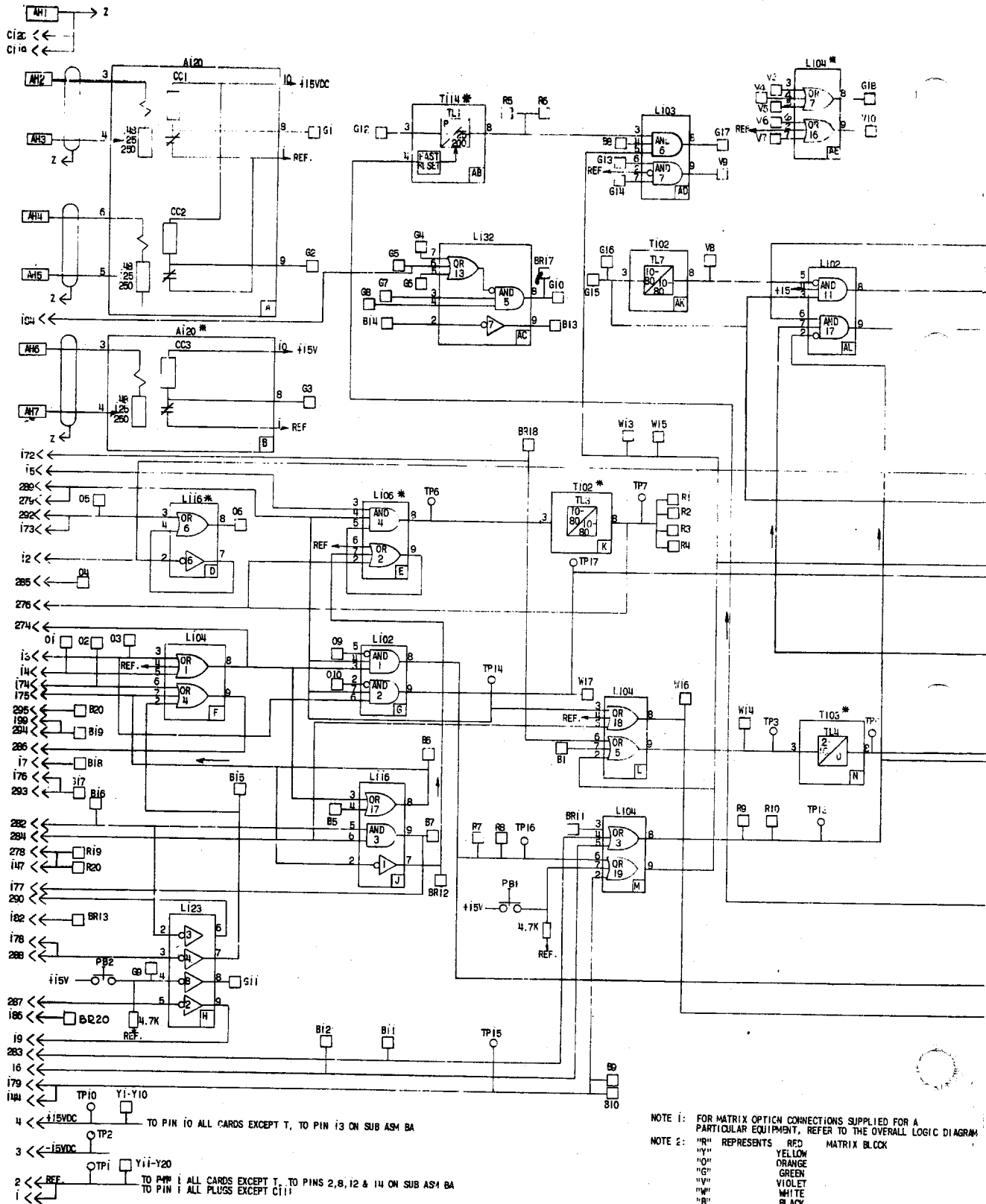

NOTE 1: FOR MATRIX OPTION CONNECTIONS SUPPLIED FOR A PARTICULAR EQUIPMENT, REFER TO THE OVERALL LOGIC DIAGRAM

NOTE 2: "R" REPRESENTS RED MATRIX BLOCK  
 "Y" REPRESENTS YELLOW MATRIX BLOCK  
 "O" REPRESENTS ORANGE MATRIX BLOCK  
 "G" REPRESENTS GREEN MATRIX BLOCK  
 "V" REPRESENTS VIOLET MATRIX BLOCK  
 "W" REPRESENTS WHITE MATRIX BLOCK  
 "B" REPRESENTS BLACK MATRIX BLOCK  
 "BR" REPRESENTS BROWN MATRIX BLOCK

C412-C416 - SINGLE OPTION LEADS } SEE MATRIX BLOCK  
 C417-C420 - DOUBLE OPTION LEADS } CONNECTION DIAGRAM  
 C421-C426 - SINGLE OPTION LEADS }  
 C427-C430 - DOUBLE OPTION LEADS }

\* Fig. 1 (0126D6277-13) Internal Cor

\* Indicates revision

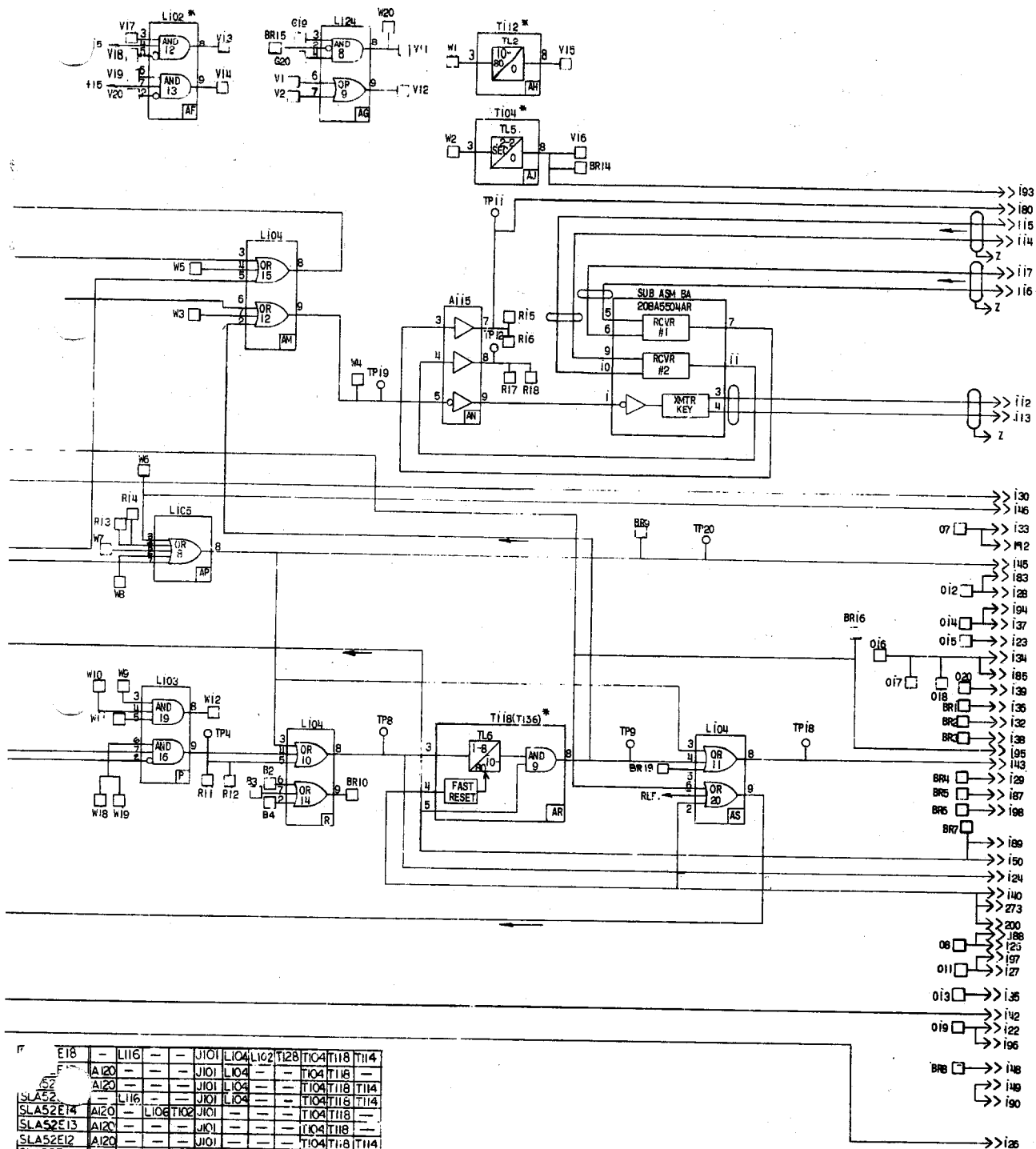

OPTION CARDS	B	D	E	K	N	IAE	IAF	IAH	IAJ	IAR	IAB
E18	-	-	-	-	-	-	-	-	-	-	-
F18	A120	-	-	-	-	-	-	-	-	-	-
G18	A120	-	-	-	-	-	-	-	-	-	-
SLA52E1	-	-	-	-	-	-	-	-	-	-	-
SLA52E14	A120	-	-	-	-	-	-	-	-	-	-
SLA52E13	A120	-	-	-	-	-	-	-	-	-	-
SLA52E12	A120	-	-	-	-	-	-	-	-	-	-
SLA52E11	A120	-	-	-	-	-	-	-	-	-	-
SLA52E10	A120	-	-	-	-	-	-	-	-	-	-
SLA52E9	-	-	-	-	-	-	-	-	-	-	-
SLA52E8	A120	-	-	-	-	-	-	-	-	-	-
SLA52E7	A120	-	-	-	-	-	-	-	-	-	-
SLA52E6	-	-	-	-	-	-	-	-	-	-	-
SLA52E5	-	-	-	-	-	-	-	-	-	-	-
SLA52E4	A120	-	-	-	-	-	-	-	-	-	-
SLA52E3	A120	-	-	-	-	-	-	-	-	-	-
SLA52E2	A120	-	-	-	-	-	-	-	-	-	-
SLA52E1	A120	-	-	-	-	-	-	-	-	-	-

Connections Diagram for the Type SLA52E



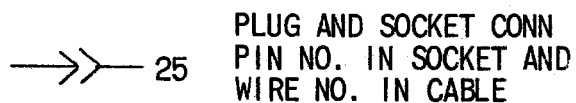
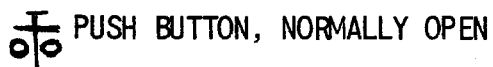
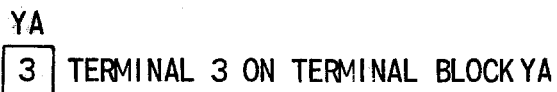
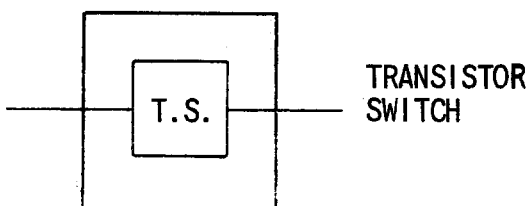
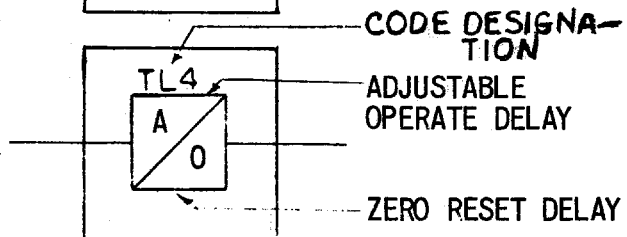
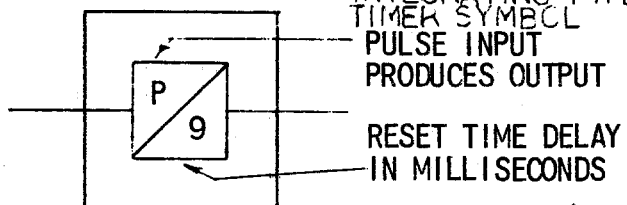
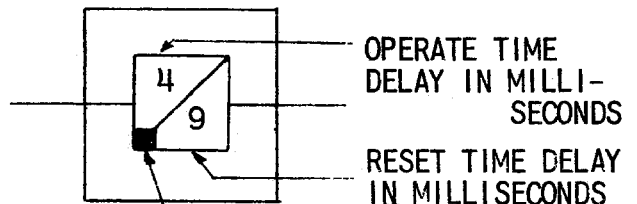
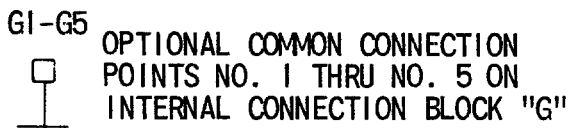
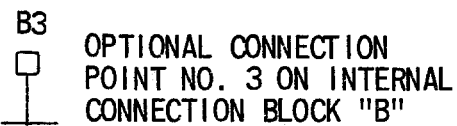
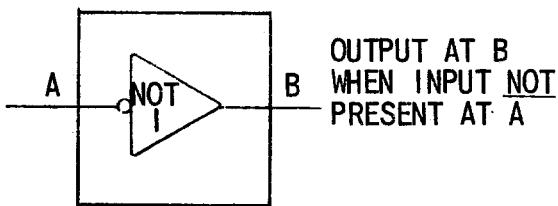
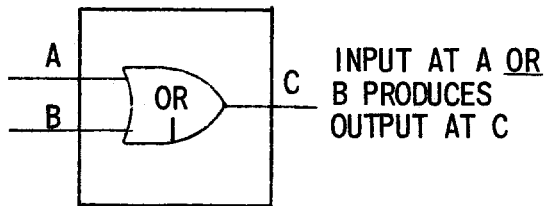
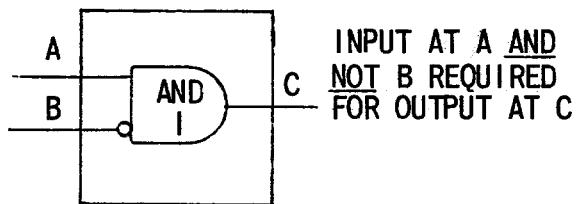
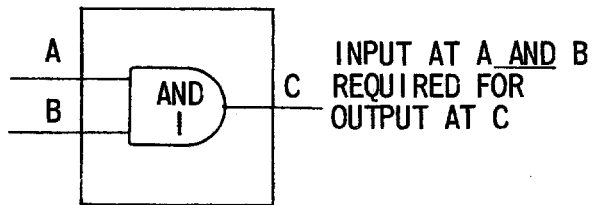
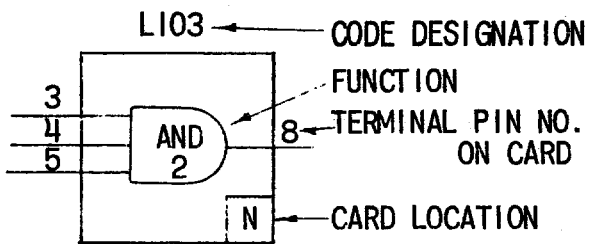

\* Fig. 2 (0227A2047-1) Internal Connection Diagram Legend

THE FOLLOWING CONNECTIONS ARE TO BE MADE TO THE  
TERMINAL BLOCKS IN THE REAR OF THE SLA LOGIC UNIT.

62

FROM	TO	FROM	TO	FROM	TO
BR12	B18	R11	REF		
B6	BR2	W3	REF		
B12	O10	W4	G19		
O4	W8	BR15	O8		
BR16	O15	G20	+15		
O6	G7	W20	BR3		
G8	+15	R15	V1		
G10	B1	R17	V2		
R1	O13	V12	G15		
R2	O19	G16	G4		
G1	G12	G5	REF		
R5	B5	G6	REF		
R6	G13	O14	O18		
W16	G14	BR19	REF		
V9	W1				
V15	V3				
G18	W6				
B7	B9				
W15	BR4				
G17	V4				
V5	REF				
W18	+15				
W14	BR1				
R10	O20				

Fig. 3 (0227A2050-1 Sh. 62) Typical Option Chart for the Type SLA52E

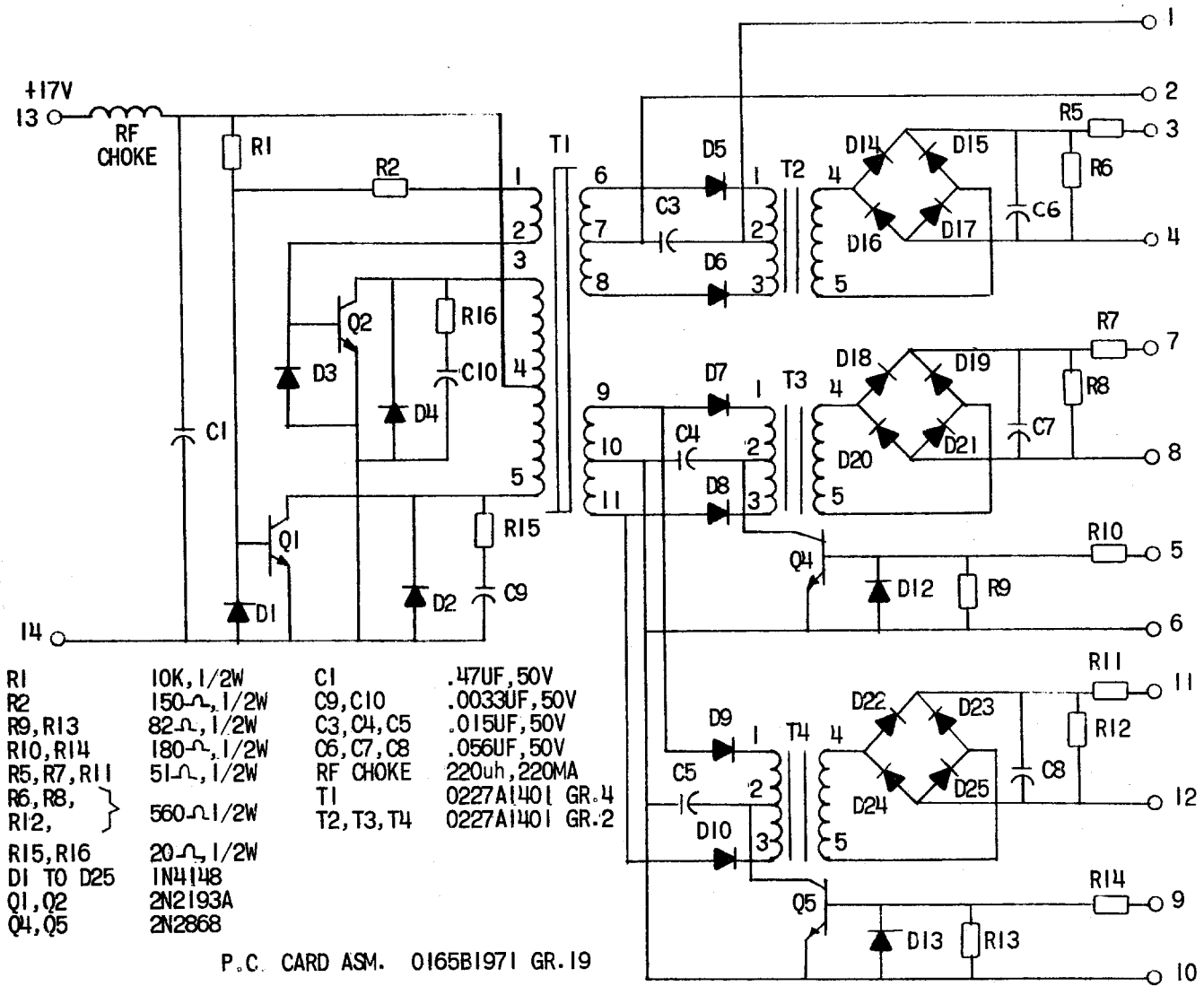
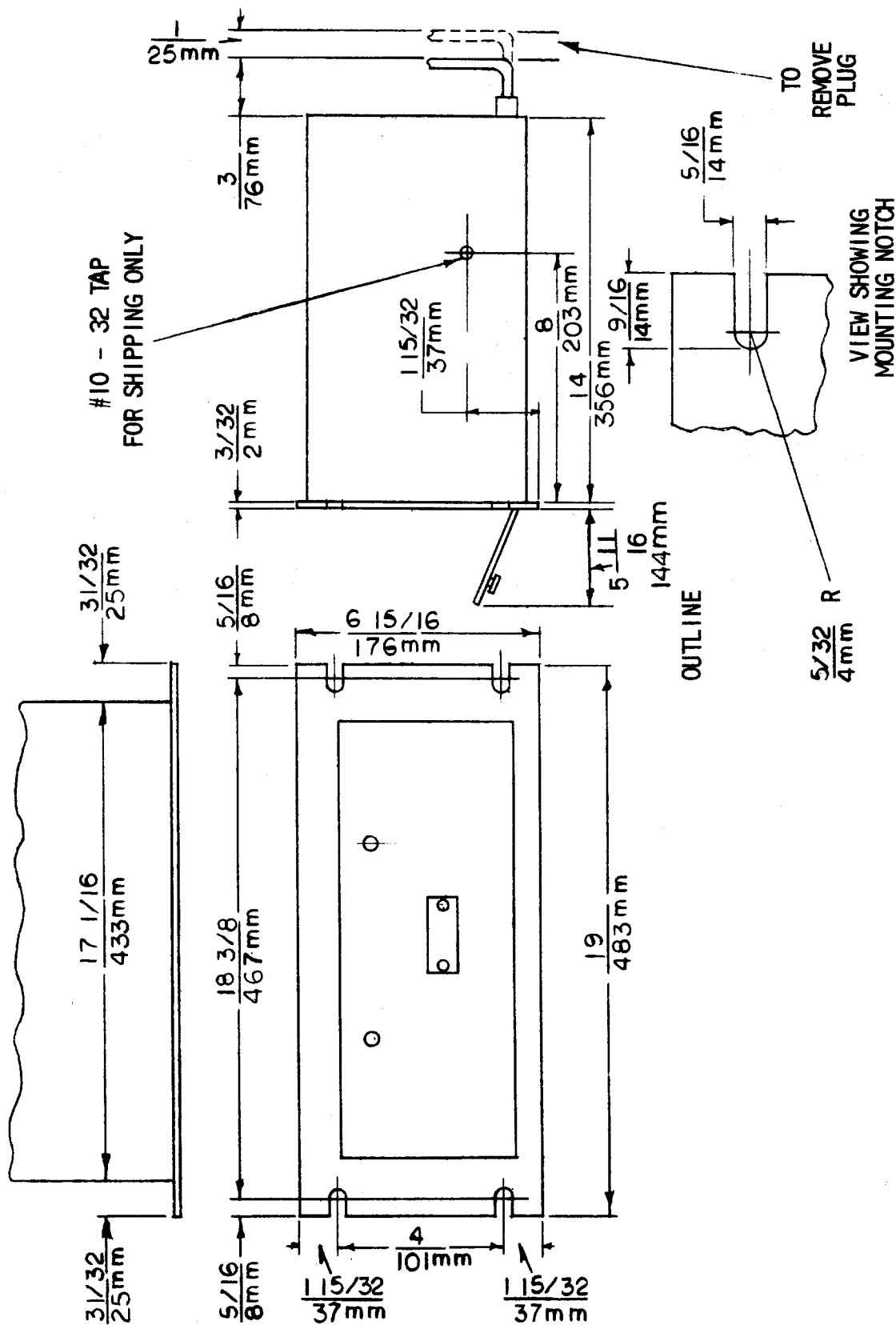
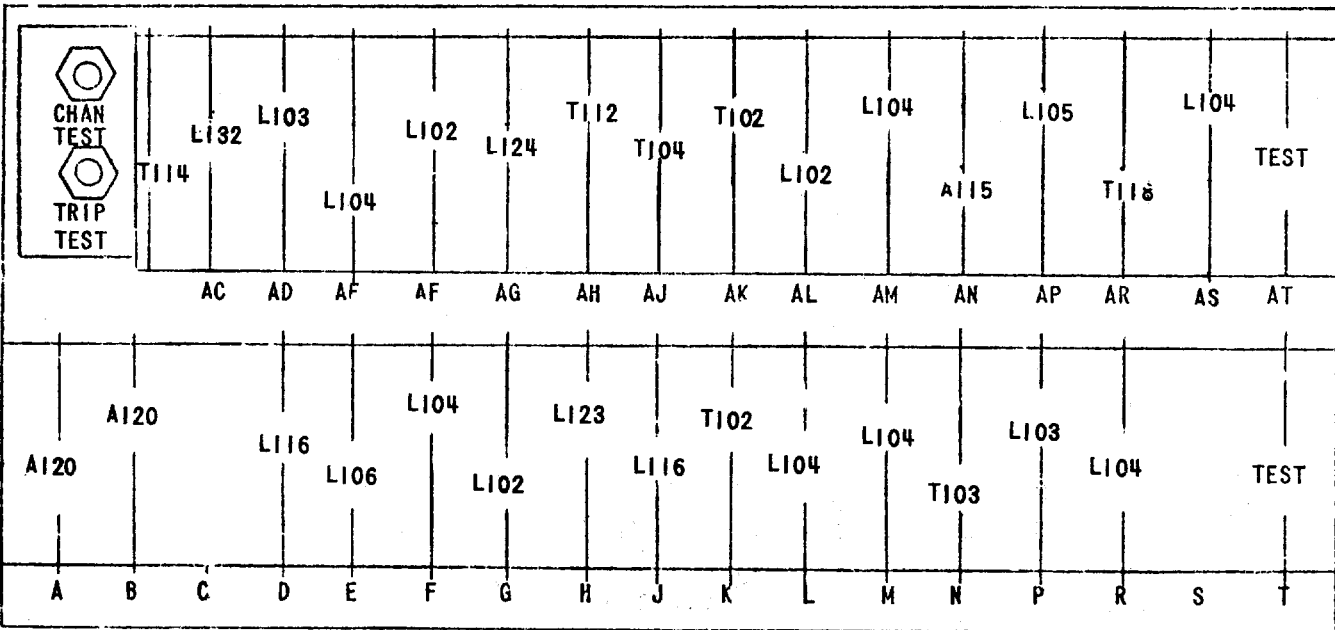
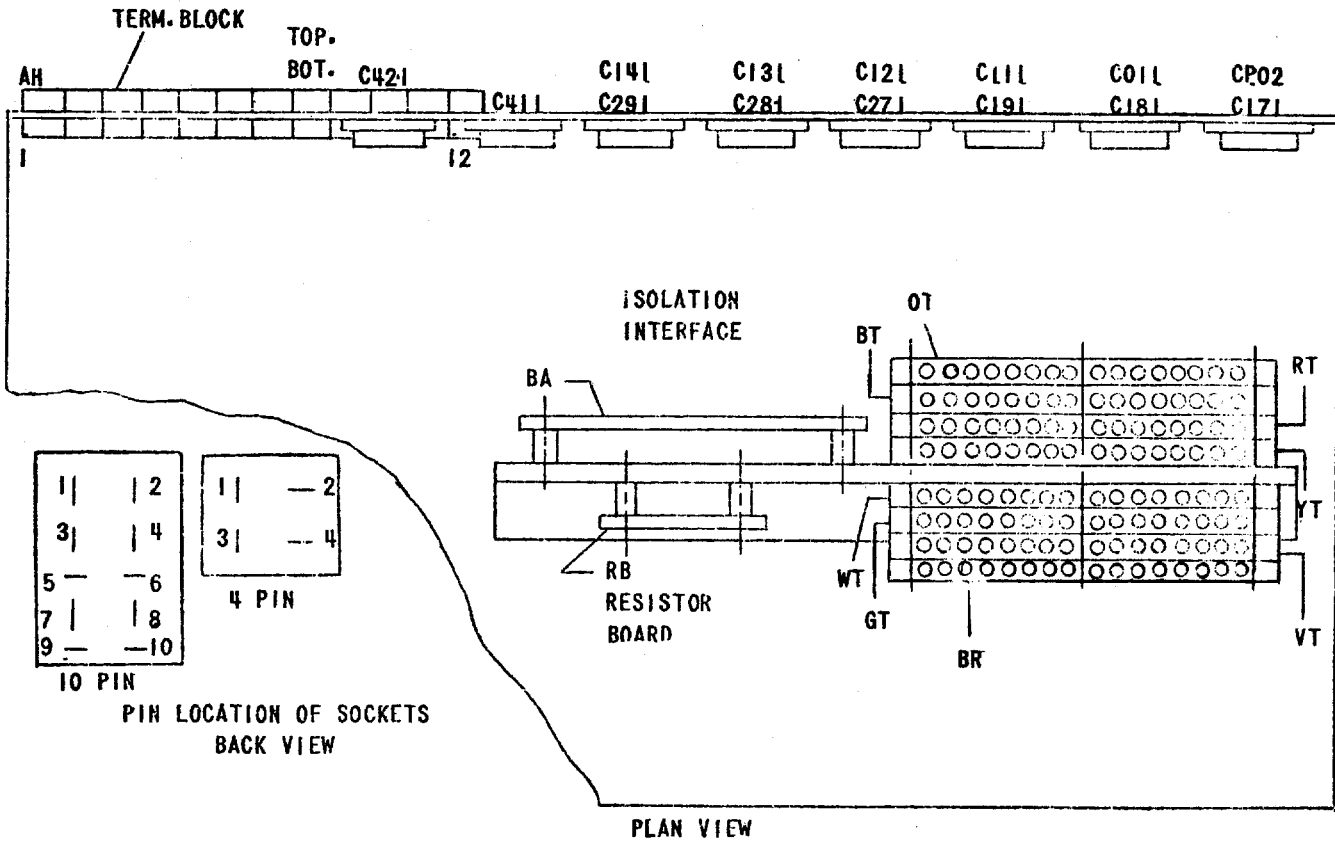

FIG. 4 (0208A5504AR-0) Isolation Interface Circuit



\* Fig. 5 (0227A2037-1) Outline and Mounting Dimensions for the Type SLA52E Relay

\* Indicates revision



\* - OPTION CARDS (SEE INTERNAL FOR CARD IDENTIFICATION-0121D9496)

Fig. 6 (0257A6256-0) Component and Card Locations for the SLA52E

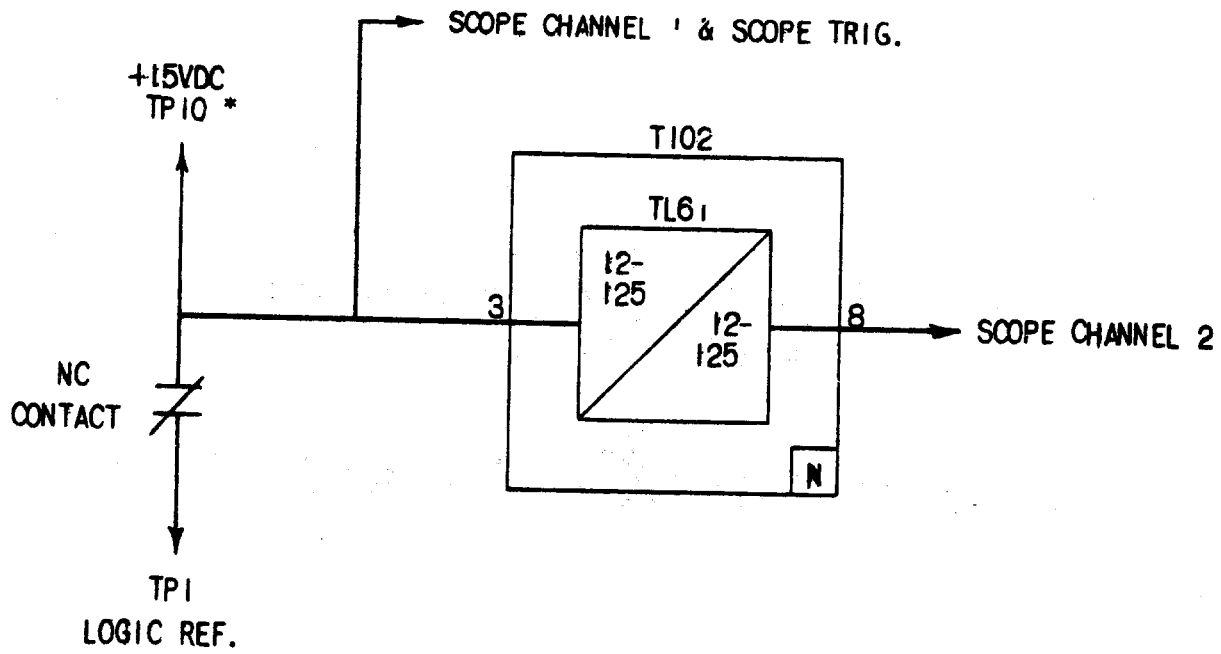

\* THE 15VDC SIGNAL AT PIN 10 HAS A CURRENT LIMITING RESISTOR MOUNTED ON THE TEST CARD.

Fig. 7 (0246A7987-0) Logic Timer Test Circuit

**GENERAL ELECTRIC COMPANY  
POWER SYSTEMS MANAGEMENT BUSINESS DEPT.  
MALVERN, PA 19355**

**GENERAL  ELECTRIC**