



INSTRUCTIONS

GEK-49920

AUXILIARY LOGIC RELAY

TYPE SLA54F

GENERAL  ELECTRIC

CONTENTS

DESCRIPTION.3
APPLICATION.3
RATINGS.3
BURDENS.4
OPERATING PRINCIPLES4
 LOGIC CIRCUIT4
 CONTACT CONVERTERS.4
 MONITORING POINTS4
 CHANNEL INTERFACE5
SETTINGS5
CONSTRUCTION5
RECEIVING, HANDLING AND STORAGE.6
INSTALLATION TESTS6
 CAUTION6
 GENERAL6
 OPERATIONAL CHECKS.6
 TEST ADAPTER.7
 TIMER ADJUSTMENTS AND TESTS7
 OVERALL EQUIPMENT TESTS7
MAINTENANCE.7
 PERIODIC TESTS.7
 TROUBLE SHOOTING.8
 SPARE PARTS8

AUXILIARY LOGIC RELAY
TYPE SLA54FDESCRIPTION

The SLA54F relay is an auxiliary logic relay designed to be used in permissive underreaching transferred trip schemes. The relay contains the necessary logic to interpret output signals from associated measuring functions and translate them to an appropriate auxiliary output and tripping relay. In addition to the SLA54F relay, proper phase and ground relays, a power supply, and auxiliary tripping relay are required to complete a particular relaying scheme.

The Type SLA54F relay is packaged in a four rack unit enclosed metal case. The relay is suitable for mounting in a 19 inch rack; the outline and mounting dimensions are shown in Fig. 1. Internal connections for the SLA54F relay are shown in Fig. 2, and the component location drawing is shown in Fig. 3.

APPLICATION

The Type SLA54F auxiliary logic relay is designed to operate in conjunction with appropriate phase and ground relays and a suitable communication channel to provide a permissive underreaching transferred tripping scheme for transmission line protection. For complete information on this scheme refer to the overall logic diagram and the accompanying logic description in which this relay is used.

Protection features required in a relay scheme often vary with the particular application. It is sometimes desirable to initially provide certain features in a relaying scheme and simultaneously to make provisions for adding or changing features should it later become necessary. To this end this relay design has incorporated circuit flexibility to permit implementation of certain optional features. To implement these features the relay is equipped with matrix connection blocks designated R, Y, OR, and B. Appropriate jumper connections are made between the various points to modify the logic.

Various points in the logic can be monitored by connecting jumpers from the cable plug 411-420 to the selected matrix points. This option is further described under the heading DATA MONITORING POINTS in the section headed OPERATING PRINCIPLES.

For the specific options and the logic arrangement supplied for a particular relaying scheme refer to the logic diagram and the logic description supplied with that scheme. If it is desired to make logic changes, the diagrams and instruction books supplied with the equipment should be studied to determine the means for implementing the changes. If further assistance is required, contact the nearest General Electric District Sales Office.

There are no measuring functions to be set in this relay but there are certain timers included that must be set in accordance with the demands of the particular protection scheme being employed and the power system on which it is being used. Refer to the section of this book headed SETTINGS for a description of these timers and for suggestions to be used in making appropriate settings.

RATINGS

The Type SLA54F relay is designed for use in an environment where the air temperature outside the relay case does not fall below -20°C or exceed $+65^{\circ}\text{C}$.

The Type SLA54F relay requires ± 15 VDC power source which can be obtained from a Type SSA power supply.

These instructions do not purport to cover all details or variations in equipment nor to provide for every possible contingency to be met in connection with installation, operation or maintenance. Should further information be desired or should particular problems arise which are not covered sufficiently for the purchaser's purposes, the matter should be referred to the General Electric Company.

To the extent required the products described herein meet applicable ANSI, IEEE and NEMA standards; but no such assurance is given with respect to local codes and ordinances because they vary greatly.

Each contact converter in this relay has a link for selecting the proper voltage for the coil circuit on the contact converter. The three possible voltages are 48 VDC, 125 VDC and 250 VDC.

BURDENS

The SLA54F relay presents a burden of 230 milliamperes to the +15 VDC supply of the Type SSA power supply.

Each contact converter, when energized, will draw approximately 10 milliamperes from the station battery, regardless of tap setting.

OPERATING PRINCIPLES

LOGIC CIRCUIT

The functions of the Type SLA54F relay involve basic logic (AND, OR, and NOT) where the presence or absence of signals, rather than their magnitudes, controls the operation. Signals are measured with respect to a reference bus accessible at TP1. In general, a signal below one VDC represents an OFF or LOGIC ZERO condition; an ON or LOGIC ONE condition is represented by a signal of approximately +15 VDC.

The symbols used on the internal connection diagram (Fig. 2) are explained by the legend shown in Fig. 4.

The matrix block options shown in the internal connections of the SLA54F relay are connected at the factory. The connections are shown on the associated overall logic and are listed on the associated option chart. A sample option chart for the Type SLA54F relay is shown in Fig. 5.

CONTACT CONVERTERS

Four contact converters are provided in the SLA54F relay. Typical functions are as follows:

- CC1 - Provides a means of keying the tone transmitter from an external contact. This is frequently used in conjunction with breaker failure schemes; matrix point B19.
- CC2 - To block pilot relay tripping upon closure of an external contact. This is usually used in connection with the channel cutoff or channel test functions in the equipment.
- CC3 - Provides a means of supervising a direct trip due to an output from the PH4 function. Through the use of an external contact, the period of time when PH-4 phase tripping will be allowed can be controlled; matrix point OR6.
- CC4 - Contact converter number four is connected to option point V2. It is typically used to provide an additional means of keying the tone transmitter from an external contact.

MONITORING POINTS

Various points within the relay logic are brought out to a cable plug mounted on the back of the SLA54F relay. This plug provides nine monitoring points plus one point for a voltage reference. Specific points that have been preselected are shown on the logic diagram marked with a number series of 411 to 420. These points may be augmented or readily changed at the matrix boards located inside the SLA relay. To monitor these points, an additional piece of equipment called a Data Logging Amplifier, DLA, is required. The outputs of the DLA are normally fed into an oscillograph which is automatically started upon the occurrence of a system disturbance. A typical selection of monitoring points is as follows:

- 412 - Phase Overcurrent
- 413 - Ground Overcurrent
- 414 - PH4
- 415 - Phase Distance
- 416 - Ground Distance
- 417 - Local Comparer Input
- 418 - Remote Comparer Input
- 419 - Comparer Output

CHANNEL INTERFACE

The logic of the Type SLA54F relay includes an isolation interface (Fig. 6) between the relays in the scheme and the associated channel. The circuitry of the isolation interface provides a signal path but maintains metallic isolation. This feature makes it possible to maintain isolation between the DC supply used for the relays and that employed by the channel.

When pins 9 and 10 are both connected to relay reference, a metallicly separate positive logic signal appears at pin 11 with respect to 12. The output from the isolation interface is a five VDC, 20 milliampere signal.

SETTINGS

The following timers in the SLA54F relay will probably require adjustment.

A/40 TIMER - The 2.5/16 timer found in the SLY62A and the A/40 timer are part of the out-of-step detection scheme. The 2.5/16 timer forms a "Tomato" (outer) characteristic; thus the distance a swing must travel before the mho (inner) characteristic is encountered is determined by the pickup setting of this timer. The A/40 timer is used to measure the time of travel between the outer and inner characteristic. An out-of-step condition will be detected when both timers are adjusted properly. The setting of both timers should be based on the results of system swing studies. However, lower pickup settings on the 2.5/16 timer (larger tomato characteristic) in conjunction with short pickup settings on the A/40 timer will enable the out-of-step protection to detect faster swings. The pickup setting of the 2.5/16 timer should not be made so low though that it will operate on load or minor swings.

B/O - C/O - These timers are used to provide the necessary coordination to prevent relay false tripping which might otherwise result from a current reversal occurring during the clearing of a parallel line fault. An analysis of the conditions and the necessary timer settings will be found in the logic description for the particular relay scheme being used. If these timers are not needed, they should be removed and replaced with jumper cards.

D/D - The D/D timer is used to coordinate the operation of the circuit breaker "b" switch with the operation of the main poles of the breaker for keying the channel transmitter. Refer to the analysis of these conditions and the suggested timer settings discussed in the logic description for the particular relay scheme being used.

3/50 - The 3/50 timer is the trip integrating timer following the comparator. The three millisecond pickup delays tripping and is arbitrarily chosen to provide a security margin in the scheme against false tripping.

CONSTRUCTION

The SLA54F relay is packaged in an enclosed metal case with hinged front covers and removable top cover. The outline and mounting dimensions of the case and the physical location of the components are shown in Figs. 1 and 3 respectively.

The SLA54F relay contains printed circuit cards identified by a code number such as A120, T102, L104 where A designates auxiliary function, T designates time-delay function, and L designates logic function. The printed circuit cards plug in from the front of the unit. The sockets are marked with letter designations or "addresses" (D,E,F, etc.) which appear on the guide strips in front of each socket, on the component location drawing, on the internal connection diagram and on the printed circuit card. The test points (TP1, TP2, etc.) shown on the internal connection diagram are connected to instrument jacks on a test card in position T or AT with TP1 at the top of the AT card. TP10 is tied to +15 VDC through a 1.5K resistor. This resistor limits the current when TP10 is used to supply a logic signal to a card.

Other logic options are selected by means of taper tip jumpers and matrix blocks. These matrix blocks are located inside the unit as shown in Fig. 3. The red (R) matrix block has ten points in five two-point common groups. The black (B) matrix block has 20 individual matrix points. The yellow (Y) block has 20 points which are grouped in ten common points: 1 to 10 are tied to +15 VDC; 11 to 20 are tied to reference. The orange (OR) block has 20 individual points identical to the black (B). The violet (V) is also identical to the black (B). A tool for inserting and removing the taper tip jumper is supplied with each relay.

RECEIVING, HANDLING AND STORAGE

These relays will normally be supplied as a part of a static relay equipment, mounted in a rack or cabinet with other static relays and test equipment. Immediately upon receipt of a static relay equipment, it should be unpacked and examined for any damage sustained in transit. If injury or damage resulting from rough handling is evident, file a damage claim at once with the transportation company and promptly notify the nearest General Electric Sales Office.

Reasonable care should be exercised in unpacking the equipment. If the equipment is not to be installed immediately, it should be stored indoors in a location that is free from moisture, dust, metallic chips, and severe atmospheric contaminants.

Just prior to final installation the shipping support bolt should be removed from each side of all relay units, to facilitate possible future unit removal for maintenance. These shipping support bolts are approximately eight inches back from the relay front panel. Static relay equipment, when supplied in swing rack cabinets, should be securely anchored to the floor or to the shipping pallet to prevent the equipment from tipping over when the swing rack is opened.

INSTALLATION TESTSCAUTION

THE LOGIC SYSTEM SIDE OF THE DC POWER SUPPLY USED WITH MOD III STATIC RELAY EQUIPMENT IS ISOLATED FROM GROUND. IT IS A DESIGN CHARACTERISTIC OF MOST ELECTRONIC INSTRUMENTS THAT ONE OF THE SIGNAL INPUT TERMINALS IS CONNECTED TO THE INSTRUMENT CHASSIS. IF THE INSTRUMENT USED TO TEST THE RELAY EQUIPMENT IS ISOLATED FROM GROUND, ITS CHASSIS MAY HAVE AN ELECTRICAL POTENTIAL WITH RESPECT TO GROUND. THE USE OF A TEST INSTRUMENT WITH A GROUNDED CHASSIS WILL NOT AFFECT THE TESTING OF THE EQUIPMENT. HOWEVER, A SECOND GROUND CONNECTION TO THE EQUIPMENT, SUCH AS A TEST LEAD INADVERTENTLY DROPPING AGAINST THE RELAY CASE, MAY CAUSE DAMAGE TO THE LOGIC CIRCUITRY. NO EXTERNAL TEST EQUIPMENT SHOULD BE LEFT CONNECTED TO THE STATIC RELAYS WHEN THEY ARE IN PROTECTIVE SERVICE, SINCE TEST EQUIPMENT GROUNDING REDUCES THE EFFECTIVENESS OF THE ISOLATION PROVIDED.

GENERAL

The SLA54F relay is supplied from the factory either mounted in a static relay equipment or as a separate unit associated with measuring relays, a Type SSA power supply, and some form of channel equipment. All relay units for a given terminal of static relaying equipment are tested together at the factory, and each unit will have the same summary number stamped on its nameplate.

In general, when a time range is indicated on the internal connection diagram, the timer has been factory set at a mid-range value. Timers should be set for the operating or reset times indicated on the associated overall logic diagram. When a time range is indicated on the overall logic diagram, the timer should be set for the value recommended for that function in the descriptive writeup accompanying the overall logic diagram. When a setting depends upon conditions encountered on a specific application, this is so stated and the factors influencing the choice of setting are described. The procedure for checking and setting the timers is described in a later section.

OPERATIONAL CHECKS

Operation of the SLA54F unit can be checked by observing the signals at the twenty test points (TP1 to TP20) in the unit, by observing the operation of the associated channel equipment, or by observing the output functions in the associated Type SLAT tripping relay. The test points are located on two test cards in positions T and AT, and are numbered 1 to 20 from top to bottom. TP1 is the reference bus for the logic circuit; TP10 is at +15 VDC. The remaining points are located at various strategic points throughout the logic as shown on the internal connection diagram, Fig. 2. Test point voltages can be monitored with a portable high impedance voltmeter, the voltmeter on the test panel of the associated equipment, or an oscilloscope.

TEST ADAPTER

The test card adapter provides a convenient means of gaining access to any pin of a particular card. Detailed information on the use of the test adapter card is included in the card instruction book GEK-34158.

TIMER ADJUSTMENTS AND TESTS

When the time-delay cards are to be adjusted or checked, an oscilloscope that can display two traces simultaneously and that has a calibrated horizontal sweep should be used.

In order to test the timer cards it is necessary to remove the card previous to the timer (see Table I) and to place the timer card in a card adapter. The card adapter allows access to the input and output of the timer if the input and output are not brought out on test points. The timer test circuit is shown in Fig. 1. Opening the normally closed contact causes the output to step up to +15 VDC after the pickup delay of the timer. To increase the pickup time turn the upper potentiometer on the timer card clockwise; to decrease the time turn it counterclockwise. Closing the contact causes the timer output to drop out after the reset time-delay setting of card. If the timer card is provided with a variable reset delay, it can be adjusted by the lower potentiometer on the timer card (clockwise increases reset time).

TABLE I

Time Under Test	Position	Remove Card in Position
TL1-2-16/0	D	B
TL2-2-16/0	G	F
TL3-32-64/40	AH	AG
TL4-2/50	P	N
TL5-.1-2 sec/0	L	K
TL6-15-100/0	AN	AM
TL7-25-100/25-100	AK	AE

OVERALL EQUIPMENT TESTS

After the SLA54F relay and the associated static relay units have been individually calibrated and tested for the desired settings, a series of overall operating circuit checks is advisable.

The elementary, overall logic, and logic description for the specific job will be useful for determining the overall operation of the scheme.

Overall equipment tests can be performed by applying AC current and voltages to the measuring units as specified in the instruction book for the measuring units and checking that proper outputs are obtained from the associated SLAT when the measuring units operate.

MAINTENANCEPERIODIC TESTS

It should be sufficient to check the outputs produced at test points in the SLA54F when periodic calibration tests are made on the associated measuring units, for example, the phase and ground relays in line relaying scheme. No separate tests on the SLA54F itself should be required.

TROUBLE SHOOTING

In any trouble shooting of an equipment, it should first be established which unit is functioning incorrectly. The overall logic diagram supplied with the equipment shows the combined logic of the complete equipment and the various test points in each unit. By signal tracing, using the overall logic diagram and the various test points, it should be possible to quickly isolate the trouble.

A test adapter card is supplied with each static relay equipment to supplement the prewired test points on the test cards. Use of the adapter card is described in the card instruction book GEK-34158.

A dual-trace oscilloscope is a valuable aid to detailed trouble shooting, since it can be used to determine phase shift, operate and reset times as well as input and output levels. A portable dual-trace oscilloscope with a calibrated sweep and trigger facility is recommended.

SPARE PARTS

To minimize possible outage time, it is recommended that a complete maintenance program should include the stocking of at least one spare card of each type. It is possible to replace damaged or defective components on the printed circuit cards, but great care should be taken in soldering so as not to damage or bridge-over the printed circuit buses, or overheat the semiconductor components. The repaired area should be recovered with a suitable high-dielectric plastic coating to prevent possible breakdowns across the printed buses due to moisture and dust. The wiring diagrams for the cards in the SLA54F relay are included in the card book GEK-34158.

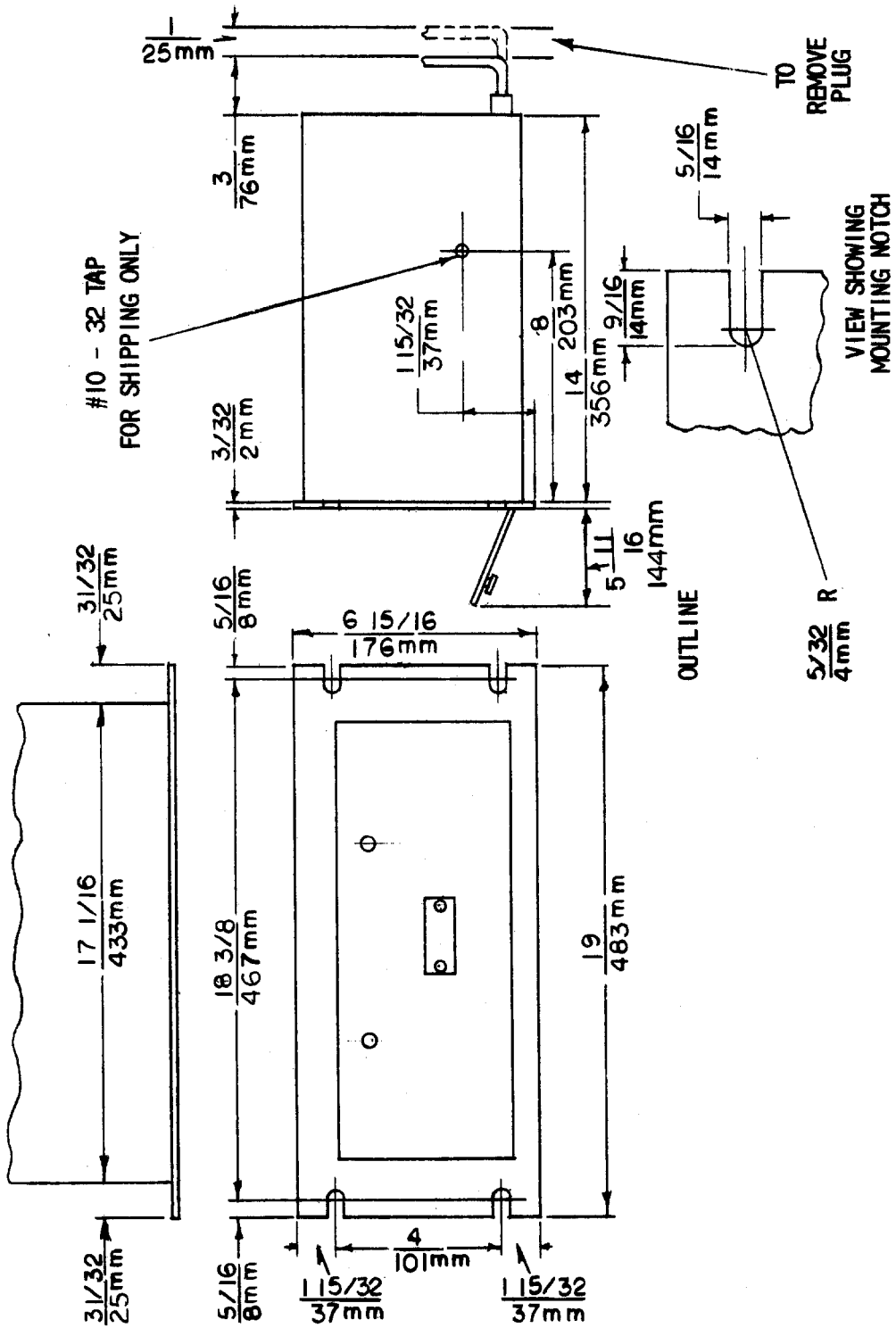

Fig. 1 (0227A2037-0) Outline and Mounting Dimensions for the Type SLA54F Relay

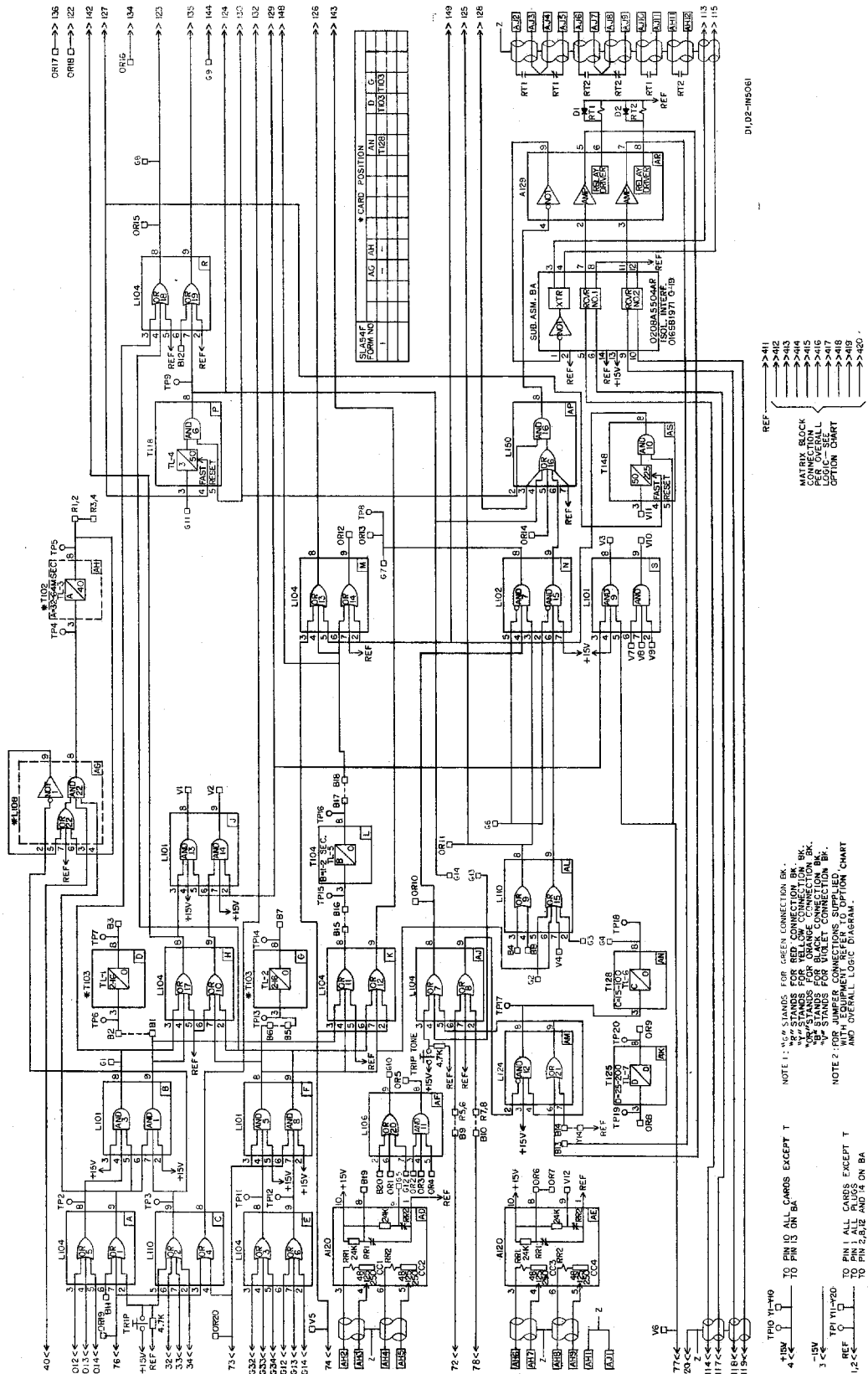
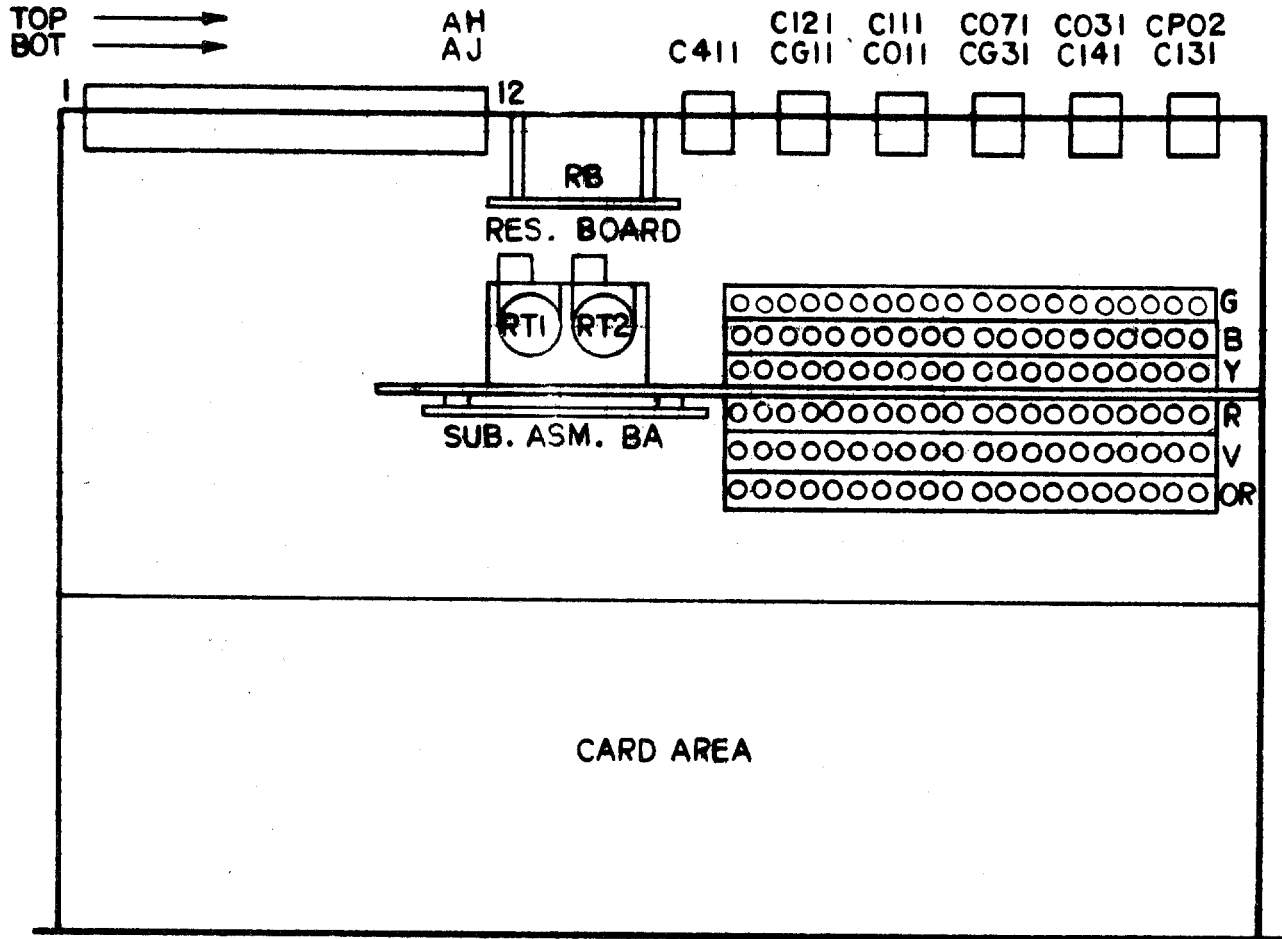
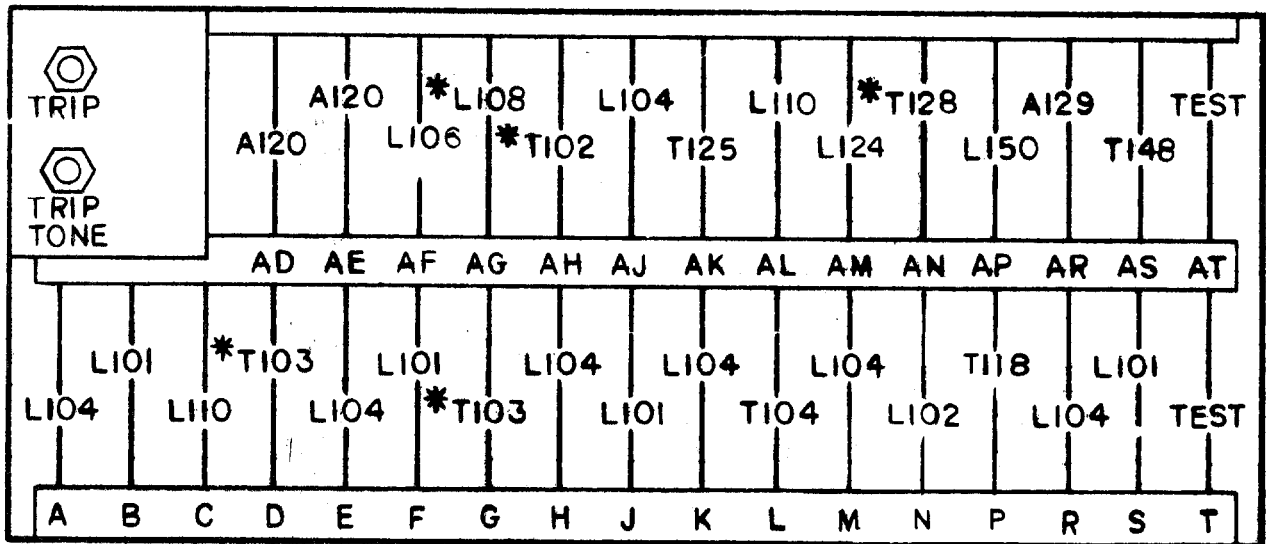

Fig. 2 (0138D2453-0) Internal Connections for the SLA54F Relay



PLAN VIEW



* WHEN REQUIRED

FRONT VIEW

Fig. 3 (0273A9118-0) Component Locations for the Type SLA54F Relay

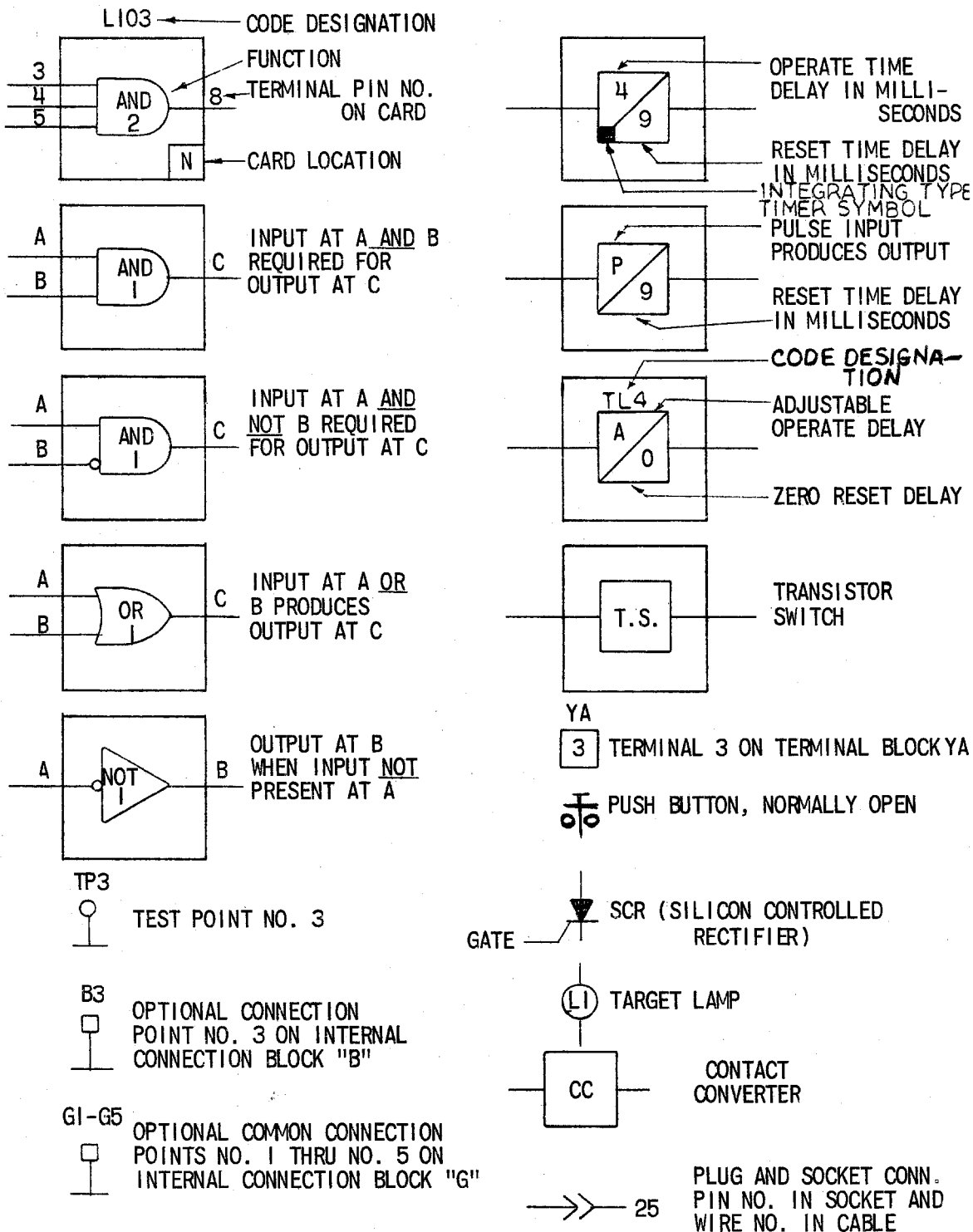
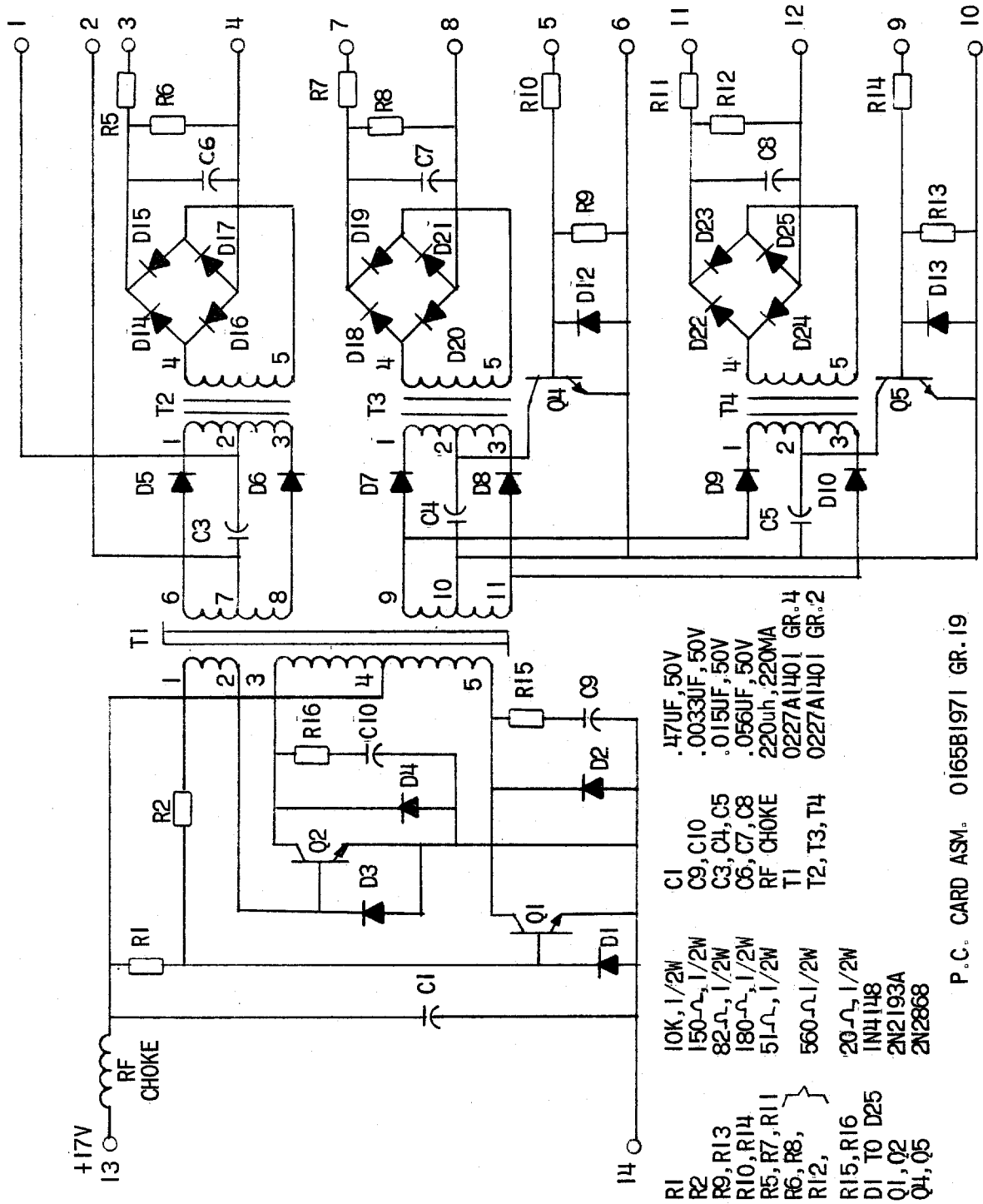

Fig. 4 (0227A2047-1) Logic and Internal Connection Diagram Legend



- R1 10K, 1/2W
- R2 150Ω, 1/2W
- R9, R13 82Ω, 1/2W
- R10, R14 180Ω, 1/2W
- R5, R7, R11 51Ω, 1/2W
- R6, R8, R12, R15 560Ω, 1/2W
- R15, R16 20Ω, 1/2W
- D1 TO D25 1N4148
- Q1, Q2 2N2193A
- Q4, Q5 2N2868
- C1 .47UF, 50V
- C9, C10 .0033UF, 50V
- C3, C4, C5 .015UF, 50V
- C6, C7, C8 .056UF, 50V
- RF CHOKE 220uh, 220MA
- T1 0227A1401 GR.4
- T2, T3, T4 0227A1401 GR.2

P.C. CARD ASM. 0165B1971 GR.19

Fig. 6 (0208A5504-0 AR) Internal Connections for Isolation Interface Used in the SLA54F Relay

**GENERAL ELECTRIC COMPANY
POWER SYSTEMS MANAGEMENT BUSINESS DEPT.**

GENERAL  ELECTRIC