



INSTRUCTIONS

GEK-86041

**SOLID STATE AUXILIARY LOGIC RELAY
FOR TRANSMISSION LINE PROTECTION
TYPE SLA51U**

GENERAL  ELECTRIC

CONTENTS

	<u>PAGE</u>
DESCRIPTION	3
APPLICATION	3
RATINGS	4
BURDENS	4
OPERATING PRINCIPLES	4
LOGIC CIRCUITS	4
CONTACT CONVERTERS	4
DATA MONITORING POINTS	5
CHANNEL INTERFACE	5
SETTINGS	5
CONSTRUCTION	5
RECEIVING, HANDLING AND STORAGE	6
INSTALLATION TESTS	6
CAUTION	6
GENERAL	6
OPERATIONAL CHECKS	7
TEST CARD ADAPTER	7
TIMER ADJUSTMENTS AND TESTS	7
TABLE I	8
CONTACT CONVERTER TESTS	8
ISOLATION INTERFACE TESTS	8
OVERALL EQUIPMENT TESTS	9
MAINTENANCE	9
PERIODIC TESTS	9
TROUBLESHOOTING	9
SPARE PARTS	9

**SOLID STATE AUXILIARY LOGIC RELAY
FOR TRANSMISSION LINE PROTECTION
TYPE SLA51U**

DESCRIPTION

The Type SLA51U relay is an auxiliary logic relay designed to be used in a directional comparison ON-OFF carrier scheme. The relay contains the necessary logic to interpret output signals from associated measuring functions and translate them to an appropriate auxiliary output and tripping relay. In addition to the SLA51U relay, appropriate ground and phase relays, plus a power supply and auxiliary tripping relay, are required to complete a particular relaying scheme.

The Type SLA51U relay is packaged in a four-rack unit enclosed metal case. The relay is suitable for mounting in a 19-inch rack, and the mounting and outline dimensions are shown in Fig. 3. Internal connections for the SLA51U relay are shown in Fig. 1, and the component and card locations are shown in Fig. 2.

APPLICATION

The SLA51U relay is designed to operate in conjunction with appropriate phase and ground relays in a directional comparison ON-OFF blocking scheme, using a Type CS26B power line carrier as the pilot channel. The SLA51U includes circuits to accommodate the use of first and second zone phase and ground distance back-up protection with the blocking directional comparison scheme. An isolation interface provides the interconnection between the SLA51U logic and the transmitter and receiver of the pilot channel.

Protection features required in a relaying scheme often vary from scheme to scheme, and it is sometimes desirable to provide certain features initially with the scheme or to provide features so that they may be added at a later date in the field. To this end, the SLA51U design has incorporated circuit flexibility to permit implementation of certain optional features.

For the specific options and the logic arrangement supplied with a particular scheme, refer to the logic diagram and logic descriptive write-up supplied with that scheme. If it is desired to make logic changes at a later date, the diagrams and instruction books supplied with a particular scheme should be studied to determine the means for implementing the changes. If further assistance is required after study of the diagrams, contact the nearest General Electric District Sales Office.

Various points in the logic can be monitored by providing jumpers from any of the available matrix points to plug 411 located on the rear of the SLA51U relay. This

These instructions do not purport to cover all details or variations in equipment nor to provide for every possible contingency to be met in connection with installation, operation or maintenance. Should further information be desired or should particular problems arise which are not covered sufficiently for the purchaser's purposes, the matter should be referred to the General Electric Company.

To the extent required the products described herein meet applicable ANSI, IEEE and NEMA standards; but no such assurance is given with respect to local codes and ordinances because they vary greatly.

option is further described in the paragraph, DATA MONITORING POINTS, under the section headed **OPERATING PRINCIPLES**.

RATINGS

The Type SLA51U relay is designed for use in an environment where the air temperature outside the relay case does not exceed minus 20°C or plus 65°C.

The Type SLA51U relay requires a plus or minus 15 volt DC power source which can be obtained from a Type SSA power supply.

Each contact converter in this relay has a link for selecting the proper voltage for the coil circuit of the contact converter. The three possible voltages are 48, 125 and 250 volts DC.

BURDENS

The SLA51U relay presents a maximum burden of 400 milliamperes to the plus 15 volt DC supply of the Type SSA power supply.

Each contact converter, when energized, will draw approximately ten milliamperes from the station battery, regardless of tap setting.

OPERATING PRINCIPLES

LOGIC CIRCUITS

The functions of the Type SLA51U involve basic logic (AND, OR, and NOT) where the presence or absence of signals, rather than their magnitude, controls the operation. Signals are measured with respect to a reference bus accessible at TP1. In general, a signal below one VDC represents an OFF or LOGIC ZERO condition; an ON or LOGIC ONE condition is represented by a signal of approximately plus 15 volts DC.

The symbols used on the internal connection diagram (Fig. 1) are explained by the legend shown in Fig. 4.

The matrix block options shown on the internal connections diagram of the SLA51U are provided at the factory. These connections are shown on the associated overall logic diagram, and are listed on the associated option chart. A sample option chart for the Type SLA51U relay is shown in Fig. 5.

CONTACT CONVERTERS

The purpose of this function is to convert a contact operation into a signal that is compatible with the logic circuitry of the relay. These contact converters, labeled CC1 through CC6, have a non-adjustable four millisecond pickup delay. Refer to the logic description for the particular scheme for information concerning the use of each contact converter.

DATA MONITORING POINTS

The Type SLA51U relay has provision for data monitoring outputs. The data monitoring (DLA) points are selected on the matrix blocks and are listed on the option chart. Any matrix block points which are not used for logic connections may be monitored. Key points in the logic have more than one matrix point to allow both logic and monitoring connections. A data logging amplifier (Type DLA) relay is used to translate the logic signals into usable outputs.

CHANNEL INTERFACE

The logic of the Type SLA51U relay includes an isolation interface (Fig. 6) between the relays in the scheme and the associated channel. The circuitry of the isolation interface provides a signal path but maintains metallic isolation. This feature makes it possible to maintain isolation between the DC supply used for the relays and that employed by the channel.

When pins 9 and 10 are both connected to relay reference, a metallically separate positive logic signal appears at pin 11 with respect to pin 12. The output from the isolation interface is a five volt DC, 20 milliamperes signal.

SETTINGS

There are certain timers in the SLA51U relay that may require field adjustment. Refer to the logic description supplied with each scheme for the settings to be made on these timers.

CONSTRUCTION

The SLA51U relay is packaged in an enclosed metal case with hinged front covers and removable top cover. The outline and mounting dimensions of the case and the physical location of the components are shown in Fig. 3 and 2, respectively.

The SLA51U relay contains printed circuit cards identified by a code number, such as A102, T102, L104; where A designates auxiliary function, T designates time-delay function, and L designates logic function. The printed circuit cards plug in from the front of the unit. The sockets are marked with letter designations or "addresses" (D, E, F, etc.) which appear on the guide strips in front of each socket, on the component location drawing, on the unit internal connection diagram, and on the printed circuit card. The test points (TP1, TP2, etc.) shown on the internal connection diagram are connected to instrument jacks on a test card in position T or AT with TP1 at the top of the AT card. TP10 is tied to plus 15 volts DC through a 1.5K resistor. This resistor limits the current when TP10 is used to supply a logic signal to a card.

Other logic options are selected by means of taper tip jumpers and matrix blocks. These matrix blocks are located in the rear of the unit as shown in Fig. 2. The green (G), red (R), black (B), orange (OR), white (W), and violet (V) matrix blocks have 20 individual matrix points. The yellow (Y) block has 20 points, which are grouped in ten common points; 1 to 10 are tied to plus 15 volts DC, 11 to 20 are tied to reference. Tools for inserting and removing taper tip jumpers are supplied with each relay.

RECEIVING, HANDLING AND STORAGE

These relays will normally be supplied as part of a static relay equipment, mounted in a rack or cabinet with other static relays and test equipment. Immediately upon receipt of a static relay equipment, it should be unpacked and examined for any damage sustained in transit. If injury or damage resulting from rough handling is evident, file a damage claim at once with the transportation company and promptly notify the nearest General Electric Sales Office.

Reasonable care should be exercised in unpacking the equipment. If the equipment is not to be installed immediately, it should be stored indoors in a location that is free from moisture, dust, metallic chips, and severe atmospheric contaminants.

Just prior to final installation the shipping support bolt should be removed from each side of all relay units, to facilitate possible future unit removal for maintenance. These shipping support bolts are approximately eight inches back from the relay front panel. STATIC RELAY EQUIPMENT, WHEN SUPPLIED IN SWING RACK CABINETS, SHOULD BE SECURELY ANCHORED TO THE FLOOR OR TO THE SHIPPING PALLET TO PREVENT THE EQUIPMENT FROM TIPPING OVER WHEN THE SWING RACK IS OPENED.

INSTALLATION TESTS

CAUTION

THE LOGIC SYSTEM SIDE OF THE DC POWER SUPPLY USED WITH MOD III STATIC RELAY EQUIPMENT IS ISOLATED FROM GROUND. IT IS A DESIGN CHARACTERISTIC OF MOST ELECTRONIC INSTRUMENTS THAT ONE OF THE SIGNAL INPUT TERMINALS IS CONNECTED TO THE INSTRUMENT CHASSIS. IF THE INSTRUMENT USED TO TEST THE RELAY EQUIPMENT IS ISOLATED FROM GROUND, ITS CHASSIS MAY HAVE AN ELECTRICAL POTENTIAL WITH RESPECT TO GROUND. THE USE OF A TEST INSTRUMENT WITH A GROUNDED CHASSIS WILL NOT AFFECT THE TESTING OF THE EQUIPMENT. HOWEVER, A SECOND GROUND CONNECTION TO THE EQUIPMENT, SUCH AS A TEST LEAD INADVERTENTLY DROPPING AGAINST THE RELAY CASE, MAY CAUSE DAMAGE TO THE LOGIC CIRCUITRY. NO EXTERNAL TEST EQUIPMENT SHOULD BE LEFT CONNECTED TO THE STATIC RELAYS WHEN THEY ARE IN PROTECTIVE SERVICE, SINCE TEST EQUIPMENT GROUNDING REDUCES THE EFFECTIVENESS OF THE ISOLATION PROVIDED.

GENERAL

If the SLA51U relay that is to be tested is installed in an equipment which has already been connected to the power system, disconnect the outputs in the associated Type SLAT relay from the system.

The SLA51U relay is supplied from the factory either mounted in a static relay equipment or as a separate unit associated with measuring relays, a Type SSA power supply, and some form of channel equipment. All relay units for a given terminal of static relaying equipment are tested together at the factory, and each unit will have the same summary number stamped on its nameplate.

In general, when a time range is indicated on the internal connection diagram, the timer has been factory set at a mid-range value. Timers should be set for the operating or reset times indicated on the associated overall logic diagram. Where a time range is indicated on the overall logic diagram, the timer should be set for the value recommended for that function in the descriptive write-up accompanying the overall logic diagram. Where a setting depends upon conditions encountered on a specific application, this is so stated and the factors influencing the choice of setting are described. The procedure for checking and setting the timers is described in a later section.

OPERATIONAL CHECKS

Operation of the SLA51U unit can be checked by observing the signals at the twenty test points (TP1 to TP20) in the SLA51U, or by observing the output functions in the associated Type SLAT tripping relay. The test points are located on two test cards in positions T and AT, and are numbered 1 to 20 from top to bottom. TP1 is the reference bus for the logic circuit; TP10 is at plus 15 volts DC and TP2 is at minus 15 volts DC. The remaining points are located at various strategic points throughout the logic as shown on the internal connection diagram (Fig. 1). Test point voltages can be monitored with a portable high impedance voltmeter, the voltmeter on the test panel of the associated equipment, or an oscilloscope.

TEST CARD ADAPTER

The test card adapter provides a convenient means of gaining access to any pin of a particular card. Detailed information on the use of the test adapter card is included in the card instruction book, GEK-34158.

TIMER ADJUSTMENTS AND TESTS

When the time-delay cards are to be adjusted or checked, an oscilloscope that can display two traces simultaneously, and that has a calibrated horizontal sweep, should be used.

In order to test the timer cards it is necessary to remove the card previous to the timer (see Table I) and to place the timer card in a card adapter. The card adapter allows access to the input and output of the timer if they are not brought out on test points. The timer test circuit is shown in Fig. 7. Opening the normally closed contact causes the output to step up to plus 15 volts DC after the pickup delay of the timer. To increase the pickup time, turn the upper potentiometer on the timer card clockwise; to decrease the time, turn it counterclockwise. Closing the contact causes the timer output to drop out after the reset time-delay setting of the card. If the timer card is provided with a variable reset delay, it can be adjusted by the lower potentiometer on the timer card (clockwise increases reset time).

TABLE I

TIMER UNDER TEST	POSITION	REMOVE CARD IN POSITION
TL1, T122 (10-80/10-80)	R	P
TL2, T111 OR T141 (1-8/0) OR (P/150-1000)	AH	**
TL3, T118 (1-8/10-80)	G	H
TL4, T102 OR T153 (10-80/10-80) OR (15-100/50-400)	L	**
TL5, T104 (0.1-2 SEC/0)	AF	**
TL6, T104 (0.1-2 SEC/0)	AG	**
TL7, T104 (0.1-2 SEC/0)	AD	**
TL8, T118 (1-8/10-80)	N	AM

** Refer to scheme logic diagram and Fig. 1 to determine card to remove.

CONTACT CONVERTER TESTS

Operation of the contact converters can be checked by placing the contact converter card in a card adapter, after checking that the voltage tap selected agrees with the station battery voltage. Connect the station direct current through a switch to the appropriate pair of terminals of the terminal strip, AH or AJ, mounted on the rear of the relay. The terminal numbers and polarity of connections for each of the contact converters are shown in the internal connection diagram, Fig. 1. Output of the contact converter card may be monitored between pins 8 or 9 and pin 1 (reference) on the card adapter with either a scope or meter. Closure of the switch in the test source will provide a plus 15 volt DC signal at pin 8 or pin 9 of the card adapter.

ISOLATION INTERFACE TESTS

Operation of the three functions (received carrier, transmitter control, and transmitter auxiliary stop) of the isolation interface can be checked without direct connections to the subassembly. External test connections are made to the pins of the C111 socket mounted on the rear of the unit, see Fig. 1. Logic circuit test connections are made at the socket pins of the channel control card in position C.

Received carrier operation test connections are shown in Fig. 8A. Do not remove the channel control card in position C for this test. Closure of the normally open contact will simulate a received carrier signal and the scope display will go from a LOGIC ZERO to a LOGIC ONE.

For the transmitter control and transmitter auxiliary stop checks, remove the channel control card, C, from its socket and replace it with a test card adapter and test card to gain access to the C socket pins. Transmitter control test connections are shown in Fig. 8B. The test contact in the open position simulates a LOGIC ONE condition which holds off the transmitter control output of the isolation interface. Closure of the normally open contact generates a LOGIC ZERO condition, initiating a

transmitter control output producing a five to six volt DC signal across the output loading resistor. The transmitter auxiliary stop function can be tested in a similar manner using the test connections of Fig. 8C, and the output again will provide a five to six volt DC signal across the output loading resistor.

OVERALL EQUIPMENT TESTS

After the SLA51U relay and the associated static relay units have been individually calibrated and tested for the desired settings, a series of overall operating circuit checks is advisable.

The elementary, overall logic and logic description for the specific job will be useful for determining the overall operation of the scheme.

Overall equipment tests can be performed by applying alternating current and voltages to the measuring units as specified in the instruction book for the measuring units and checking that proper outputs are obtained from the associated SLAT when measuring units operate.

MAINTENANCE

PERIODIC TESTS

It should be sufficient to check the outputs produced at test points in the SLA51U when periodic calibration tests are made on the associated measuring units, for example, the phase and ground relays in line-relaying scheme. No separate periodic tests on the SLA51U itself should be required.

TROUBLESHOOTING

In any troubleshooting of equipment, it should first be established which unit is functioning incorrectly. The overall logic diagram supplied with the equipment shows the combined logic of the complete equipment and the various test points in each unit. By signal tracing, using the overall logic diagram and the various test points, it should be possible to quickly isolate the trouble.

SPARE PARTS

To minimize possible outage time, it is recommended that a complete maintenance program should include the stocking of at least one spare card of each type. It is possible to replace damaged or defective components on the printed circuit cards, but great care should be taken in soldering so as not to damage or bridge-over the printed circuit buses, or overheat the semiconductor components. The repaired area should be recovered with a suitable high-dielectric plastic coating to prevent possible breakdowns across the printed buses due to moisture and dust. The wiring diagrams for the cards in the SLA51U relay are included in the card instruction book, GEK-34158.

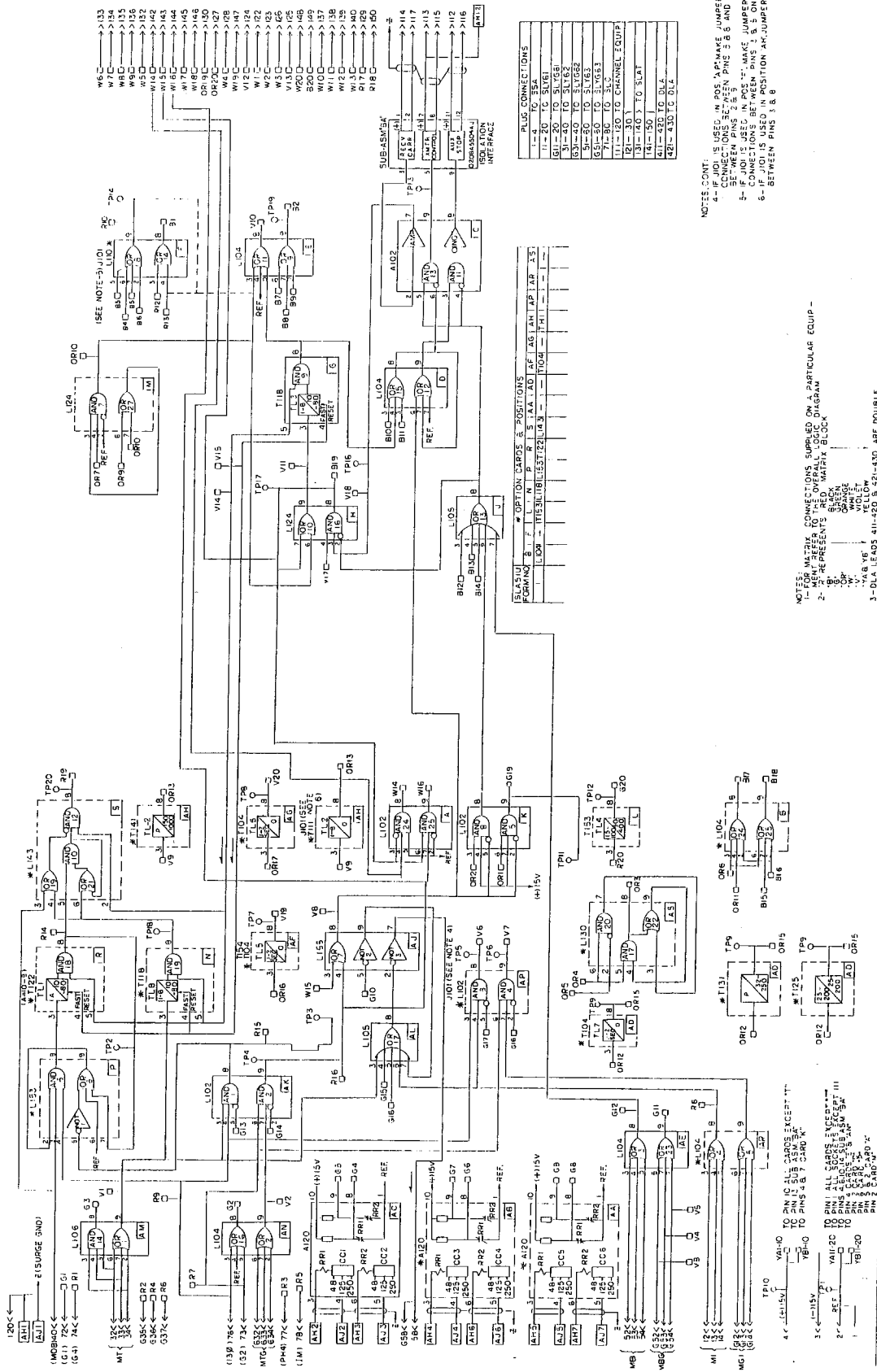
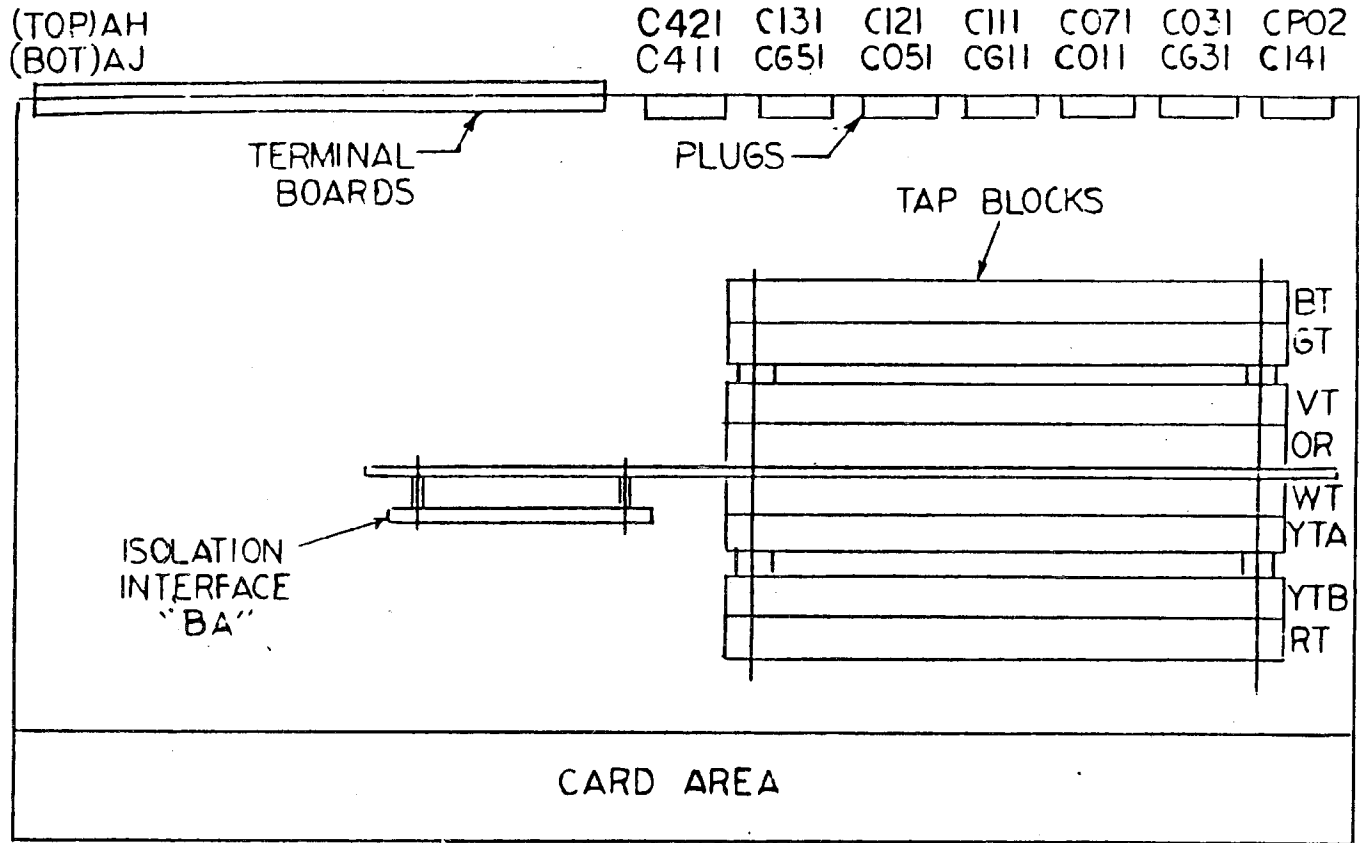

Fig. 1 (0145D8648-0) Internal Connection Diagram for the SLA51U Relay



PLAN VIEW

* OPTICNAL CARDS

	*A120	*T131 *T125	*T104 T154	*T111 J101	LI02	LI06	*LI02 J101	*LI30								
*A120	A120		LI04	T104	LI55	LI05	LI04	*LIC4	TEST							
AA	AB	AC	AD	AE	AF	AG	AH	AJ	AK	AL	AM	AN	AP	AR	AS	AT
	*LI04		LI04	*LI10 J101		LI24		LI02	LI24		*LI53		*LI43			
LI02		A102		LI04		T118		LI05	*T153	*T118		*T122				TEST
A	B	C	D	E	F	G	H	J	K	L	M	N	P	R	S	T

FRONT VIEW

Fig. 2 (0285A6212) Component Location Diagram for the SLA51U Relay

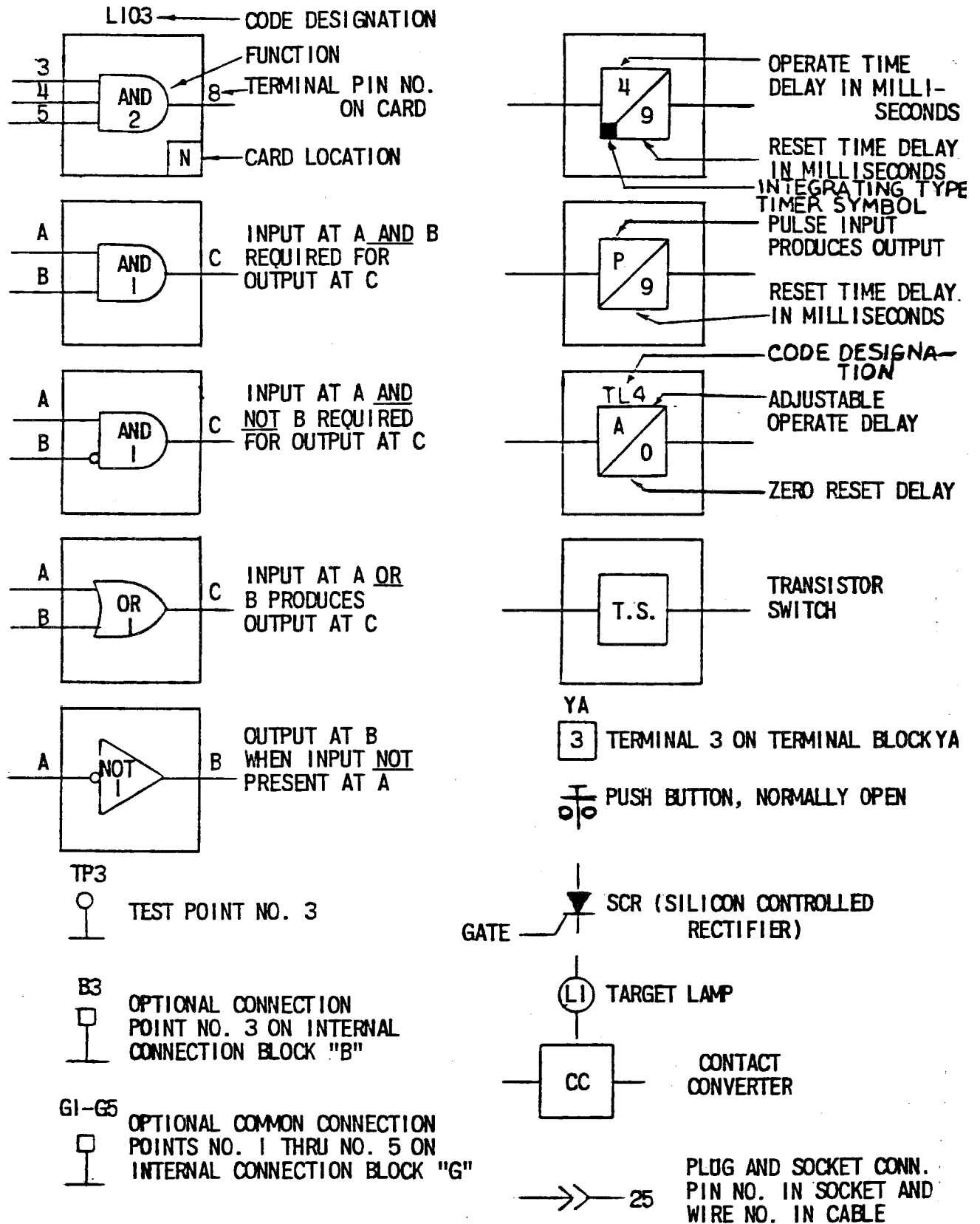

Fig. 4 (0227A2047-1) Logic And Internal Connection Diagram Legend

THE FOLLOWING ARE FACTORY CONNECTIONS MADE AT THE MATRIX BLOCKS INSIDE OF THE SLA RELAY ASSOCIATED WITH THIS EQUIPMENT.
 SYMBOLS LISTED: PL=RELAY INTERCONNECTING CABLE LEAD
 (5)=LOGIC FUNCTION CARD PIN NUMBER
 ‡=3-WAY CONNECTION
 * =DLA MONITOR CONNECTION AVAILABLE BUT NOT USED
 Δ=4-WAY CONNECTION

262

MATRIX BLOCK JUMPERS		LOGIC FUNCTION		MATRIX BLOCK JUMPERS		LOGIC FUNCTION	
FROM	TO	FROM	TO	FROM	TO	FROM	TO
OR20	V14	C127	AND18(5)	ΔR19	OR6	AND12(8)	OR24(3)
R2	PL412	CG35	DLA	ΔR19	B8	AND12(8)	OR9(7)
PL412	B12	DLA	OR13(3)	ΔR19	W5	AND12(8)	C132
R6	G19	CG37	AND5(9)	W7	PL416	C134	DLA
‡G1	OR1	C72	AND5(6)	V10	OR11	OR11(8)	OR24(4)
‡G1	R4	C72	CG36	ΔV19	R11	TL5(8)	OR25(2)
G2	W3	OR16(8)	PL126	ΔV19	B9	TL5(8)	OR9(2)
R15	V9	AND1(8)	TL2(3)	ΔV19	W20	TL5(8)	C148
‡OR13	W15	TL2(8)	OR7(3)	B2	W6	OR9(9)	C133
‡OR13	OR16	TL2(8)	TL5(3)	OR18	V13	OR24(8)	C125
V8	PL414	OR7(8)	DLA	OR14	V12	OR25(9)	C124
PL414	V17	DLA	AND16(4)				
R5	G10	C078	NOT2(5)				
R3	OR9	C077	OR27(6)				
R1	OR10	C074	OR27(7)				
G7	R20	CC4(9)	TL4(3)				
G20	OR7	TL4(8)	AND7(4)				
OR18	B7	AND7(8)	OR9(6)				
G6	OR2	CC3(8)	AND8(3)				
‡G5	B13	CC2(9)	OR13(4)				
‡G5	B10	CC2(9)	OR15(3)				
G4	B11	CC1(8)	OR15(5)				
V18	PL415	AND16(3)	DLA				
B19	W2	AND16(8)	C123				
W14	PL417	AND24(8)	DLA				
W16	PL418	AND25(9)	DLA				
G13	YA11	AND1(5)	REF.				
G14	YA12	AND2(2)	REF.				
R8	YA13	OR17(6)	REF.				
G16	YA14	OR17(4)	REF.				
G15	YA15	OR17(5)	REF.				
B14	YA16	OR13(5)	REF.				
W1	YA17	C122	REF.				
G12	PL413	OR3(8)	DLA				
V11	OR14	OR10(9)	OR25(7)				
R14	PL419	AND18(8)	DLA				

Fig. 5 (0227A2050-0, Sh. 262) Sample Option Chart for the SLA51U Relay

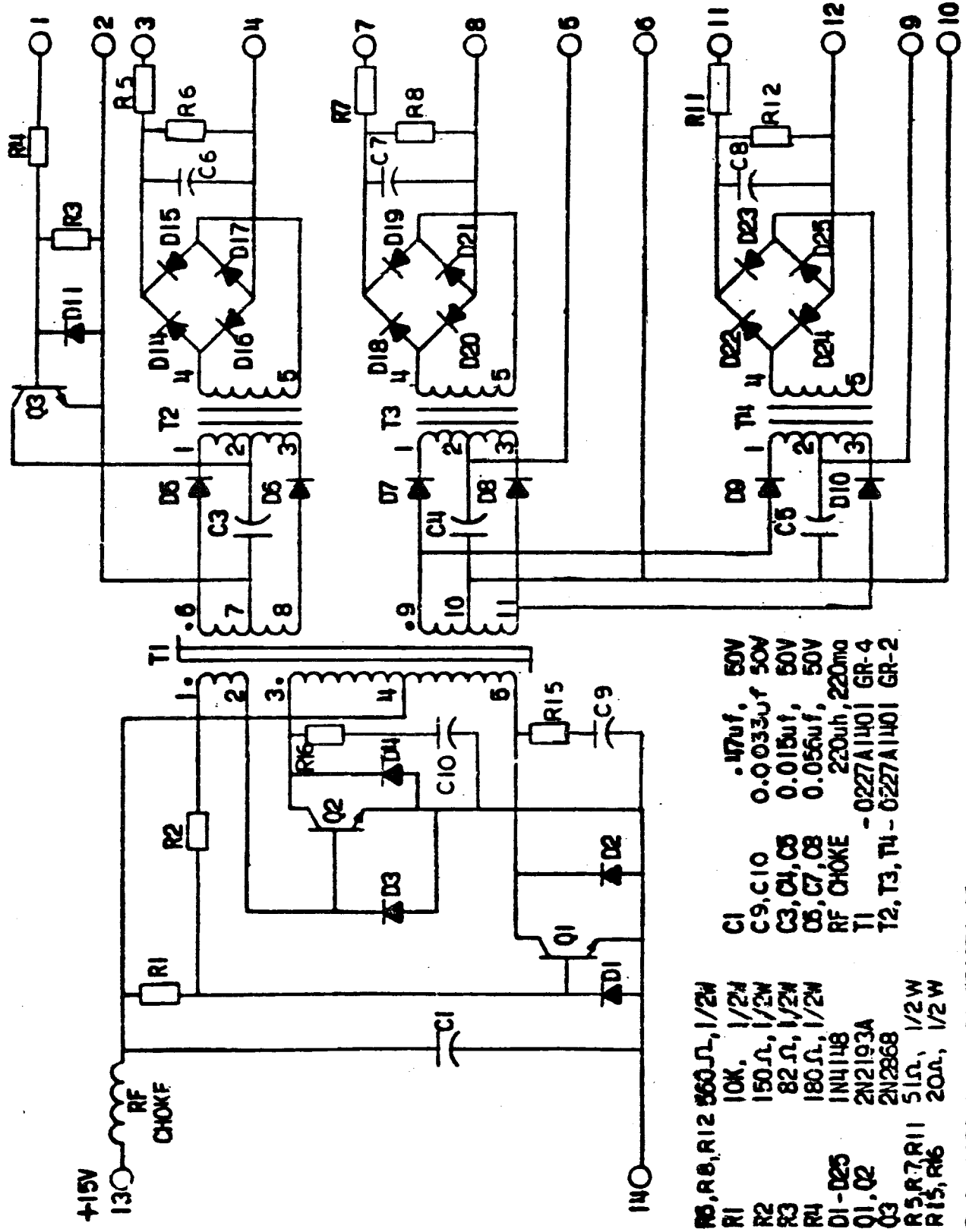

- R5, R6, R12 560Ω, 1/2W
- R1 10K, 1/2W
- R2 150Ω, 1/2W
- R3 82Ω, 1/2W
- R4 180Ω, 1/2W
- D1 - D25 1N4148
- Q1, Q2 2N2193A
- Q3 2N2868
- R5, R7, R11 51Ω, 1/2 W
- R15, R16 20Ω, 1/2 W
- C1 .17uF, 50V
- C9, C10 0.0033uF 50V
- C3, C4, C8 0.015uF, 50V
- C5, C7, C8 0.056uF, 50V
- RF CHOKE 220uH, 220ma
- T1 - 0227A1401 GR-4
- T2, T3, T4 - 0227A1401 GR-2

P.C. CARD ASM. 0165B197; GR-13

Fig. 6 (0208A5504AJ-1) Isolation Interface Circuit

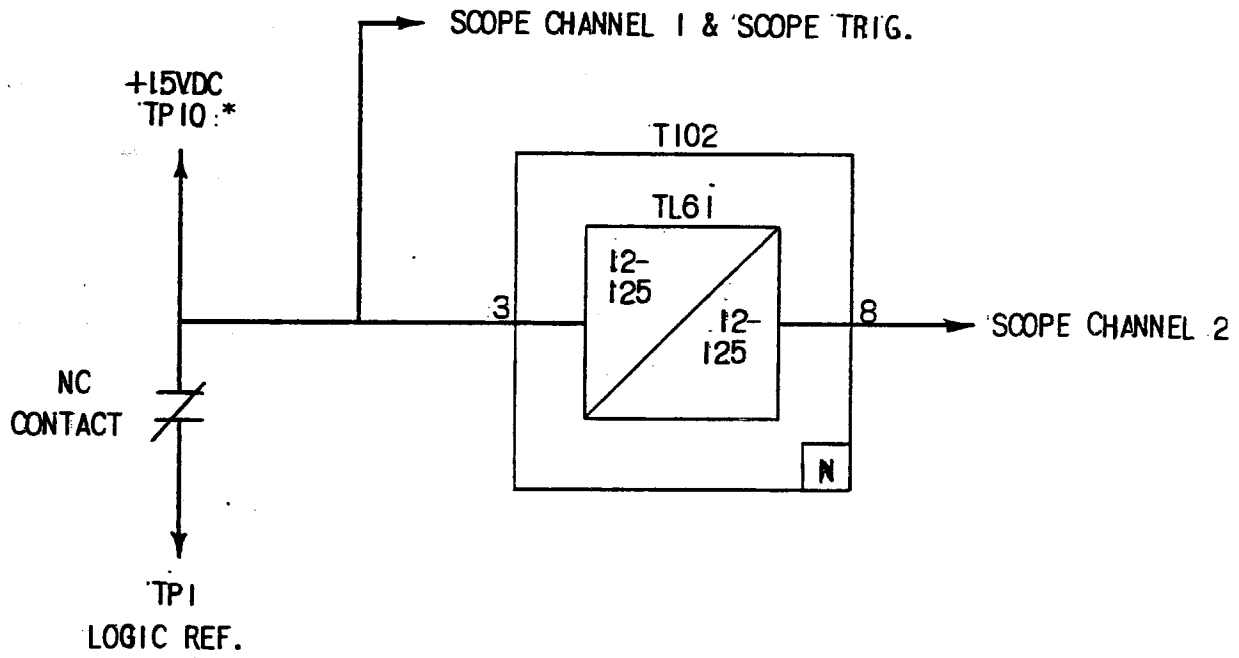

* THE 15VDC SIGNAL AT PIN 10 HAS A CURRENT LIMITING RESISTOR MOUNTED ON THE TEST CARD.

Fig. 7 (0246A7987-0) Logic Timer Test Circuits

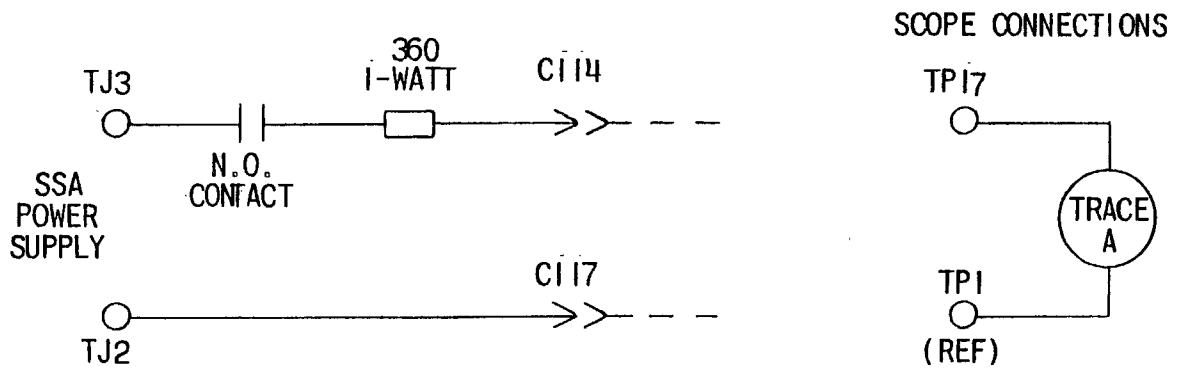

A-RECEIVED CARRIER TEST CONNECTIONS

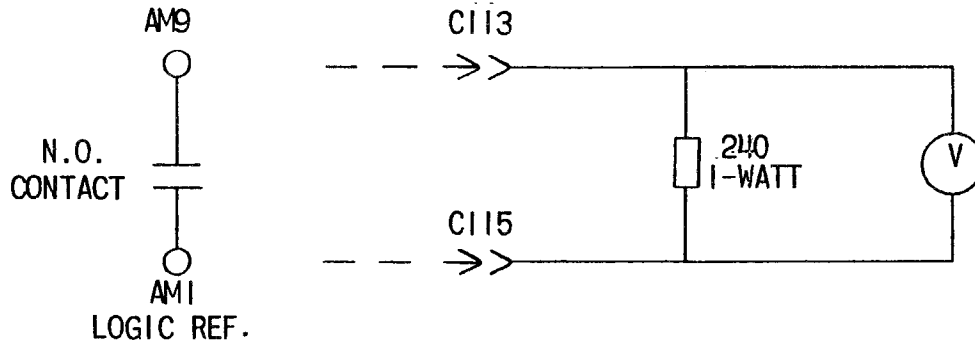

B-TRANSMITTER CONTROL TEST CONNECTIONS

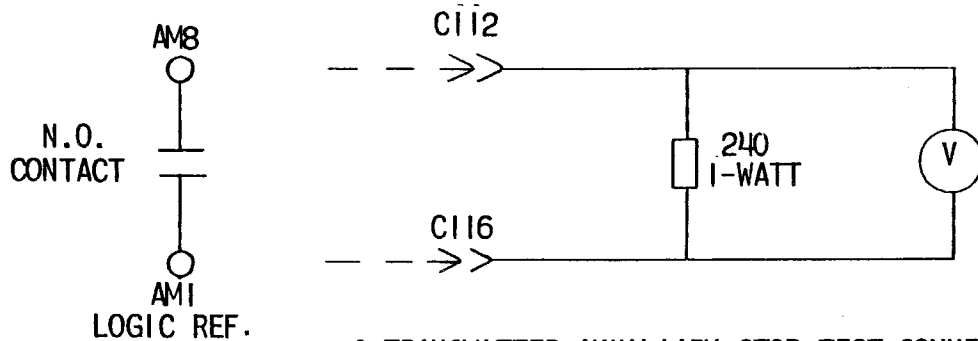

C-TRANSMITTER AUXILIARY STOP TEST CONNECTIONS

Fig. 8 (0257A6244-0) Isolation Interface Test Circuits

**GENERAL ELECTRIC COMPANY
POWER SYSTEMS MANAGEMENT BUSINESS DEPT.
MALVERN, PA. 19355**

GENERAL  ELECTRIC