



**INSTRUCTIONS**

**GEK-36779A**  
Supersedes GEK-36779

AUXILIARY LOGIC AND TRIPPING UNIT

TYPE SLAT61A

---

**GENERAL  ELECTRIC**

CONTENTS

	<u>PAGE</u>
DESCRIPTION.....	3
APPLICATION.....	3
RATINGS.....	3
BURDENS.....	4
FUNCTIONS.....	4
SCR TRIP CIRCUIT.....	4
RI RECLOSE INITIATE CIRCUIT.....	4
BFI BREAKER FAILURE INITIATE CIRCUIT.....	4
CONTACT CONVERTERS.....	4
CC41.....	4
CHANNEL INTERFACE.....	4
CALCULATIONS OF SETTINGS.....	4
SYMMETRY ADJUSTMENT.....	5
PHASE DELAY ADJUSTMENT.....	5
DATA MONITORING POINTS.....	5
TARGETS.....	5
LOGIC CIRCUITS.....	5
CONSTRUCTION.....	5
RECEIVING, HANDLING AND STORAGE.....	6
TEST INSTRUCTIONS.....	6
CAUTION.....	6
OPERATIONAL CHECKS.....	6
TEST CARD ADAPTER.....	6
TIMER ADJUSTMENTS AND TESTS.....	6
TABLE I.....	7
TRIP CIRCUIT TESTS.....	7
OVERALL EQUIPMENT TESTS.....	7
SYMMETRY AND PHASE TIMER ADJUSTMENTS.....	7
MAINTENANCE.....	8
PERIODIC TESTS.....	8
TROUBLE SHOOTING.....	8
SPARE PARTS.....	8

AUXILIARY LOGIC AND TRIPPING UNITSLAT61ADESCRIPTION

The SLAT61A relay is a static logic, output and tripping unit for use in phase comparison schemes utilizing an ON-OFF blocking carrier channel. In addition to the SLAT61A relay, the appropriate phase comparison measuring unit, a power supply and the appropriate ON-OFF channel equipment are required to complete a particular relaying scheme.

The outputs of the SLAT61A include two electrically separate SCR trip outputs each with an electro-mechanical target; two electrically separate reclose initiating contacts (RI); and two electrically separate breaker failure timer initiating contacts. The inputs to the SLAT61A are the associated relays and channel equipment and a contact converter that may be energized by an external contact to stop all carrier transmission.

The SLAT61A relay is packaged in a two rack unit enclosed metal case suitable for mounting on a 19 inch rack. The outline and mounting dimensions are shown in Figure 1. The internal connections for the SLAT61A relay are shown in Figure 2. The component and card locations are shown in Figure 3.

There are two DC ratings available. One for 250 volts and the other for 48/125 volts.

APPLICATION

The SLAT61A relay is designed to operate in conjunction with appropriate phase comparison measuring units and a ON-OFF carrier equipment in a phase comparison blocking scheme.

There are nine points which may be monitored from Data Monitoring Points on the rear of the SLAT61A relay. These points are indicated in Figure 2. If these points are to be monitored, a separate data logging amplifier (DLA) is required.

There are no measuring functions to be set in the SLAT61A, but there are included two timers that need to be field adjusted. These are the symmetry adjustment and the phase delay adjustment. Refer to the section titled "CALCULATION OF SETTINGS" for a discussion regarding the considerations pertaining to the required settings.

The (BFI) contacts are reed relay contacts and are not applicable for use in trip circuits. See the ratings section for contact duty capability.

For the complete description of the overall scheme in which the relay is employed, refer to the overall logic diagram and its associated logic description that is supplied with each terminal equipment.

RATINGS

The Type SLAT61A relay is designed for use in an environment where the air temperature outside the relay case does not exceed  $-20^{\circ}\text{C}$  and  $+65^{\circ}\text{C}$ .

The Type SLAT61A relay requires a  $\pm 15$  VDC power source which can be obtained from a Type SSA power supply.

The SCR tripping circuits are rated for 48/125 or 250 VDC. Each has a 1.0 ampere series target. The tripping circuits are designed to carry 30 amperes for one second.

The contacts of the telephone type relays that are used for RI will make and carry three amperes continuously and will interrupt up to 0.5 amperes (inductive) at 125 VDC or 0.25 ampere (inductive) at 250 VDC.

The contacts of the reed relays that are used for BFI are rated for 100 watts DC. They will make and carry three amperes continuously.

*These instructions do not purport to cover all details or variations in equipment nor to provide for every possible contingency to be met in connection with installation, operation or maintenance. Should further information be desired or should particular problems arise which are not covered sufficiently for the purchaser's purposes, the matter should be referred to the General Electric Company.*

*To the extent required the products described herein meet applicable ANSI, IEEE and NEMA standards; but no such assurance is given with respect to local codes and ordinances because they vary greatly.*

Refer to the unit nameplate for the ratings of a particular relay.

#### BURDENS

The SLAT61A relay presents a maximum burden to the Type SSA power supply of:

200 ma (standby) 280 ma (operated) from the +15 VDC supply  
 10 ma (standby) 125 ma (operated) from the -15 VDC supply

Each contact converter, when energized, will draw approximately 10 milliamperes, from the station battery, regardless of the tap setting.

#### FUNCTIONS

##### SCR TRIP CIRCUIT

Two electrically separate, isolated SCR trip circuits are provided to trip two breakers. Each circuit is capable of carrying 30 amperes for one second.

The internal connections for the SCR trip and isolator subassemblies are shown in Figure 4. The isolator card, by means of a DC-to-DC converter, provides a signal path but maintains metallic isolation. This feature makes it possible to isolate the relay power from the trip circuit power supply.

##### RI RECLOSE INITIATE CIRCUIT

Two electrically separate normally open contacts are provided. These contacts close within 17 milliseconds from the time the associated coil is energized by the logic. The contacts open within 170 milliseconds from the time the coil is deenergized. The RI function uses a telephone-type relay with contact ratings stated under RATINGS.

##### BFI BREAKER FAILURE INITIATE CIRCUIT

Two electrically separate normally open contacts are provided. These contacts close within two milliseconds from the time the associated coil is energized by the logic. These contacts open within two milliseconds from the time the coil is deenergized. The BFI function uses a reed relay with contact ratings stated under RATINGS.

##### CONTACT CONVERTERS

The purpose of this function is to convert a contact operation into a signal that is compatible with the logic circuit of the Type SLAT61A relay. The contact converter is labeled CC41. This contact converter has a non-adjustable four millisecond pickup delay.

##### CC41

Contact converter 41 is energized by an external contact to stop carrier transmission.

##### CHANNEL INTERFACE

The logic of the Type SLAT61A relay includes an isolation interface (Figure 6) between the relays in the scheme and the associated channel. The circuitry of the isolation interface provides a signal path but maintains metallic isolation. This feature makes it possible to maintain isolation between the DC supply used for the relays and that employed by the channel.

When pins 9 and 10 are both connected to relay reference, a metallicly separate positive logic signal appears at pin 11 with respect to 12. The output from the isolation interface is a 5 VDC, 20 milliamperes signal.

#### CALCULATIONS OF SETTINGS

The SLAT61A contains five timers. Three of the timers are factory set and do not generally need field adjustment. The two timers that require field adjustment are the symmetry and phase delay timers. The symmetry adjustment should be set first. However, before either setting is made, the communication equipment should be completely tested and have its final settings made.

SYMMETRY ADJUSTMENT

This 0-3/0 timer is included to compensate for any assymetry that may exist in the pickup and dropout of the channel equipment. The purpose of this setting is to assure that the near end comparer receives equal on and off half cycles when the transmitter at the remote end is keyed for equal on and off half cycles. See the section titled SYMMETRY AND PHASE-DELAY TIMER ADJUSTMENTS for instructions for making this setting in the field.

PHASE DELAY ADJUSTMENT

This 1-8/1-8 timer is intended to delay the local input to the comparer by exactly the same amount of time that it takes for the remote signal to arrive. This time is equal to the channel delay in the communication equipment plus the propogation time of the signal. This setting should be made after the symmetry adjustment setting discussed above.

Because both of the above timer settings are affected by service conditions, the settings cannot be made at the factory. For instructions relating to the method of adjustment, see the SYMMETRY AND PHASE-DELAY TIMER ADJUSTMENTS section of this book.

DATA MONITORING POINTS

Data monitoring points are brought out on a plug at the rear of the SLAT61A relay. The plug contains nine monitoring points and reference as shown on the overall logic diagram for the scheme. To monitor these points an additional piece of equipment termed a Data Logging Amplifier is required.

TARGETS

Two electromechanical target coils are included, one in series with each SCR. These targets operate on one ampere of trip current when the associated SCR passes current. The trip circuit resistance in the relay is 0.40 ohm.

LOGIC CIRCUITS

The functions of the Type SLAT61A involves basic logic (AND, OR, and NOT) where the presence or absence of signals, rather than their magnitude, controls the operation. Signals are measured with respect to a reference bus accessible at TP1. In general a signal below one VDC represents an OFF or LOGIC ZERO condition, an ON or LOGIC ONE is represented by a signal of approximately +15 VDC.

The symbols used on the internal connection diagram (Fig. 2) are explained by the legend shown in Fig. 5.

CONSTRUCTION

The SLAT61A relay is packaged in an enclosed metal case with hinged front cover and removable top cover. The outline and mounting dimensions of the case and the physical location of the components are shown in Figures 1 and 3 respectively.

The SLAT61A relay contains printed circuit cards identified by a code number such as: A104, T106, L109 where A designates an auxiliary function, T designates a time delay function, and L designates a logical function. The printed circuit cards plug in from the front of the unit. The sockets are marked with letter designations or "addresses" (D, E, F, etc.) which appear on the guide strips in front of each socket, on the component location drawing, on the unit internal connection diagram, and on the printed circuit card. The test points (TP1, TP2, etc.) shown on the internal connection diagram are connected to instrument jacks on a test card in position T with TP1 at the top of the T card. TP1 is tied to reference; TP10 is tied to +15 VDC through a 1.5K resistor. This resistor limits the current when TP10 is used to supply a logic signal to a card.

The SLAT61A relay receives its inputs from the associated Type SLD relay. These units are interconnected by ten conductor shielded cables. The sockets for these cables are located on the rear panel of the unit. The SLAT61A output functions are connected to 12-point terminal strips, which are also located on the rear of the unit.

A window is provided in the hinged cover of the relay to allow the mechanical targets to be seen. Push buttons are also provided to reset the targets without opening the cover.

RECEIVING, HANDLING AND STORAGE

These relays will normally be supplied as a part of a static relay equipment, mounted in a rack or cabinet with other static relays and test equipment. Immediately upon receipt of a static relay equipment, it should be unpacked and examined for any damage sustained in transit. If injury or damage resulting from rough handling is evident, file a damage claim at once with the transportation company and promptly notify the nearest General Electric Sales Office.

Reasonable care should be exercised in unpacking the equipment. If the equipment is not to be installed immediately, it should be stored indoors in a location that is free from moisture, dust, metallic chips, and severe atmospheric contaminants.

Just prior to final installation the shipping bolt should be removed from each side of all relay units, to facilitate possible future unit removal for maintenance. These shipping bolts are approximately eight inches back from the relay front panel. Static relay equipment, when supplied in swing rack cabinets, should be securely anchored to the floor or to the shipping pallet to prevent the equipment from tipping over when the swing rack is opened.

CAUTION

THE LOGIC SYSTEM SIDE OF THE DC POWER SUPPLY USED WITH MOD III STATIC RELAY EQUIPMENT IS ISOLATED FROM GROUND. IT IS A DESIGN CHARACTERISTIC OF MOST ELECTRONIC INSTRUMENTS THAT ONE OF THE SIGNAL INPUT TERMINALS IS CONNECTED TO THE INSTRUMENT CHASSIS. IF THE INSTRUMENT USED TO TEST THE RELAY EQUIPMENT IS ISOLATED FROM GROUND, ITS CHASSIS MAY HAVE AN ELECTRICAL POTENTIAL WITH RESPECT TO GROUND. THE USE OF A TEST INSTRUMENT WITH AGROUND CHASSIS WILL NOT AFFECT THE TESTING OF THE EQUIPMENT. A SECOND GROUND CONNECTION TO THE EQUIPMENT, SUCH AS A TEST LEAD INADVERTENTLY DROPPING AGAINST THE RELAY CASE, MAY CAUSE DAMAGE TO THE LOGIC CIRCUITRY. NO EXTERNAL TEST EQUIPMENT SHOULD BE LEFT CONNECTED TO THE STATIC RELAYS WHEN THEY ARE IN PROTECTIVE SERVICE, SINCE TEST EQUIPMENT GROUNDING REDUCES THE EFFECTIVENESS OF THE ISOLATION PROVIDED. IF THE RELAY IS INSTALLED IN AN EQUIPMENT IN SERVICE DISCONNECT ITS OUTPUTS BEFORE CONDUCTING ANY TESTS.

GENERAL

The SLAT61A relay is supplied from the factory either mounted in a static relay equipment or as a separate unit associated with measuring relays, a Type SSA power supply, and some form of channel equipment. All relay units for a given terminal of static relaying equipment are tested together at the factory, and each will have the same summary number stamped on its nameplate.

In general, when a time range is indicated on the internal connections diagram, the timer has been factory set at a mid-range value. Timers should be set for the operating or reset times indicated on the associated overall logic diagram. Where a time range is indicated on the overall logic diagram, the timer should be set for the value recommended for that function in the descriptive write-up accompanying the overall logic diagram. Where a setting depends upon conditions encountered on a specific application, this is so stated and the factors influencing the choice of setting are described. The procedure for checking and setting the timers is described in a later section.

OPERATIONAL CHECKS

Operation of the SLAT61A unit can be checked by observing the signals at the ten test points (TP1 to TP10) in the SLAT61A by observing the operation of the associated channel equipment, or by observing the output functions. The test points are located on a test card in positions T, and are numbered 1 to 10 from top to bottom. TP1 is the reference bus for the logic circuit, TP10 is at +15 VDC. The remaining points are located at various strategic points throughout the logic as shown in the internal connection diagram (Figure 2). Test point voltages can be monitored with a portable high impedance voltmeter, the voltmeter on the test panel of the associated equipment, or an oscilloscope.

TEST CARD ADAPTER

The test card adapter provides a convenient means of gaining access to any pin of a particular card. Detailed information on the use of the test adapter card is included in the card instruction book GEK-34158.

TIME ADJUSTMENTS AND TESTS

When the time delay cards are to be adjusted or checked, an oscilloscope that can display two traces simultaneously and that has a calibrated horizontal sweep should be used.

In order to test the timer cards it is necessary to remove the card previous to the timer (see Table I) and to place the timer card in a card adapter. The card adapter allows access to the input and out put of the timer if they are not bought out on test points. The timer test circuit is shown in Figure 7. Opening the normally closed contact causes the output to step up to +15 VDC after the pickup delay of the timer. To increase the pickup time, turn the upper potentiometer on the timer card clockwise; to decrease the timer turn it counter clockwise. Closing the contact causes the timer output to drop out after the reset time-delay setting of the card. If the timer card is provided with a variable reset delay, it can be adjusted by the lower potentiometer on the timer card clockwise increases reset time).

TABLE I

TIME UNDER TEST	POSITION	REMOVE CARD IN POSITION
TL41	J	E
TL42	H	G
TL43	N	C
TL44	M	NONE *
TL45	L	K

\* Turn power supply switch on and off.

#### TRIP CIRCUIT TESTS

The SCR trip circuits and the series mechanical targets may be checked by connecting an auxiliary lockout relay, such as the Type HEA relay, in series with the SCR circuit. A typical circuit is shown in Figure 8. The HEA relay should have the same DC ratings as the SCR trip circuit of the SLAT61A. If an auxiliary lockout relay is not available, it can be replaced by a resistive load which limits the trip circuit current to three amperes. In most equipments, the SCR can be gated by operating a test push button in the associated units.

Prior to final installation, a check of the overall trip circuit should be made with the SCR outputs connected to trip the circuit breakers.

#### OVERALL EQUIPMENT TESTS

After the SLAT61A relay and the associated static relay units have been individually calibrated and tested for the desired settings and ranges, a series of overall operating circuit checks is advisable. The elementary, overall logic and logic description for the specific job will be useful for determining the overall operation of the scheme.

Overall equipment tests can be performed by applying AC current and voltages to the measuring units as specified in the instruction book for the measuring units and checking that proper outputs are obtained when the measuring units operate.

#### SYMMETRY AND PHASE-DELAY TIMER ADJUSTMENTS

The symmetry timer (TL42, "H" position) and phase-delay timer (TL41, "J" position) final settings must be made in the field after the transmitters, receivers and coupling equipment have been tuned and adjusted for proper sensitivity per the channel instructions. Operation of the squaring amplifier and fault detectors, FDL and FDH, are required for accomplishment of the final symmetry and phase delay adjustments; refer to the measuring unit instruction book for the recommended procedure.

The symmetry adjustment must be accomplished prior to phase-delay adjustments as described in the measuring unit instructions. The transient blocking timer (TL43, "N" position) should be removed to prevent continuous channel keying when the logic trip bus is energized. Clockwise adjustment of P1 and P2 on TL42, "H" position card, increases the pickup delay or dropout delay respectively. Conversely, counterclockwise adjustment reduces the respective operate times. The minimum delay on pickup which allows equal half cycle block and trip output as measured at TP8 is the recommended final setting.

After the symmetry adjustment has been accomplished, the phase-delay adjustment is made to obtain the proper alignment of the local signal with the received signal; refer to the measuring unit instructions. Clockwise adjustment of P1 or P2 on TL41, "S" position card, increases the pickup or dropout delay respectively. The final setting is the alignment of the trip attempt signal monitored at TP4 compared to the trip or block signal monitored at TP8 which is dependent upon internal or external fault simulation during the adjustment.

## MAINTENANCE

### PERIODIC TESTS

It should be sufficient to check the outputs produced at test points in the SLAT61A when periodic calibration tests are made on the associated measuring units, for example, the phase and ground relays in line relaying scheme. No separate periodic tests on the SLAT61A itself should be required.

### TROUBLE SHOOTING

In any trouble shooting of equipment, it should first be established which unit is functioning incorrectly. The overall logic diagram supplied with the equipment shows the combined logic of the complete equipment and the various test points in each unit. By signal tracing, using the overall logic diagram and the various test points, it should be possible to quickly isolate the trouble.

A test adapter card is supplied with each static relay equipment to supplement the prewired test points on the test cards. Use of the adapter card is described in the card instruction book GEK-34258.

A dual trace oscilloscope is a valuable aid to detailed trouble shooting, since it can be used to determine phase shift, operate and reset times as well as input and output levels. A portable dual-trace oscilloscope with a calibrated sweep and trigger facility is recommended.

### SPARE PARTS

To minimize possible outage time, it is recommended that a complete maintenance program should include the stocking of at least one spare card of each type. It is possible to replace damaged or defective components on the printed circuit cards, but great care should be taken in soldering so as not to damage or bridge-over the printed circuit buses, or overheat the semi-conductor components. The repaired area should be recovered with a suitable high-dielectric plastic coating to prevent possible breakdowns across the printed buses due to moisture and dust. The wiring diagrams for the cards in the SLAT61A relay are included in the card book GEK-34158.



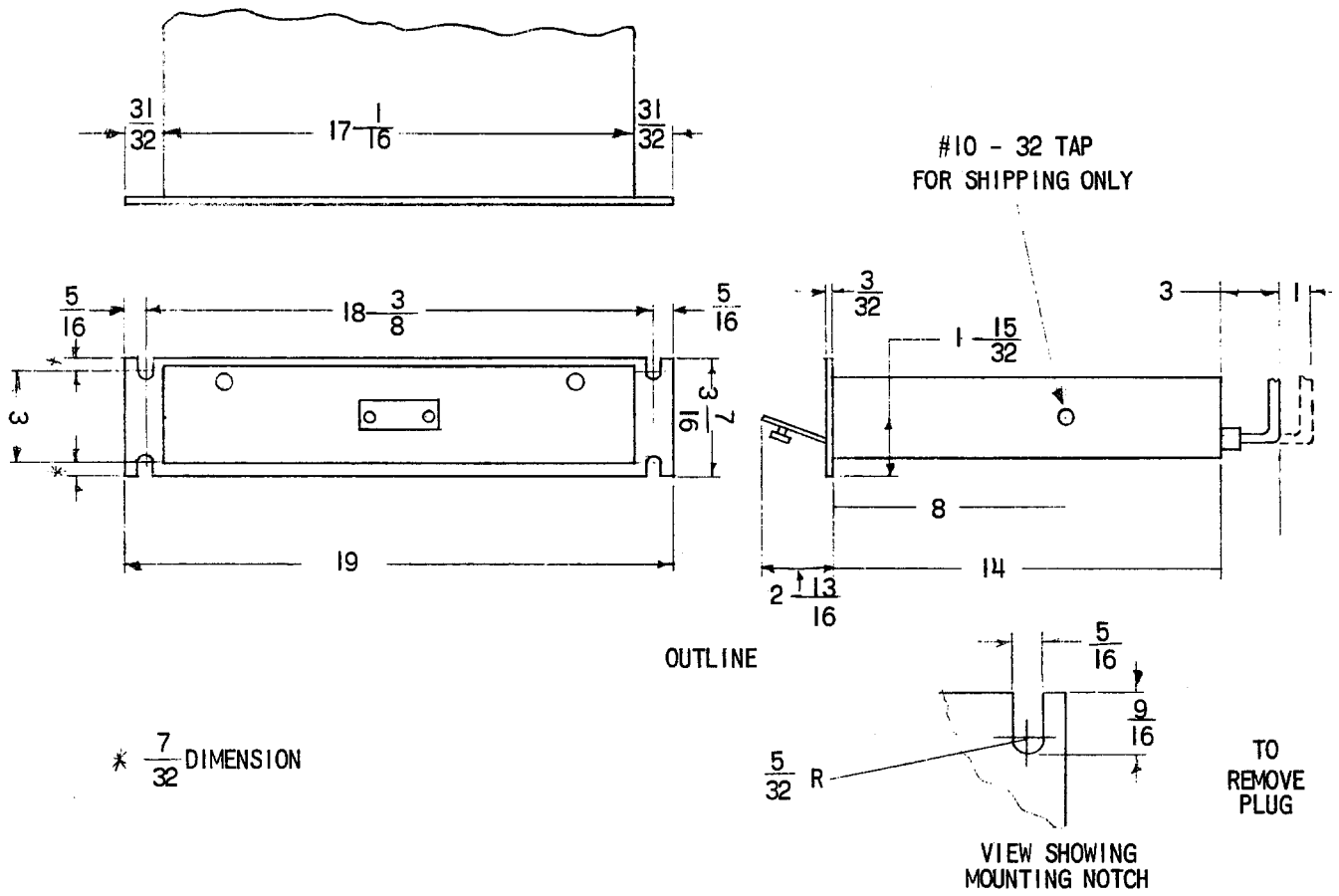

FIG. 1 (0227A2036-0) Outline And Mounting Dimensions For The Type SLAT61 Relay

NOTE 1: MODEL SLAT61A1,2 USES J101 CARD WHICH PUTS PIN 8 AT REFERENCE  
 MODEL SLAT61A3,4 USES T117 CARD

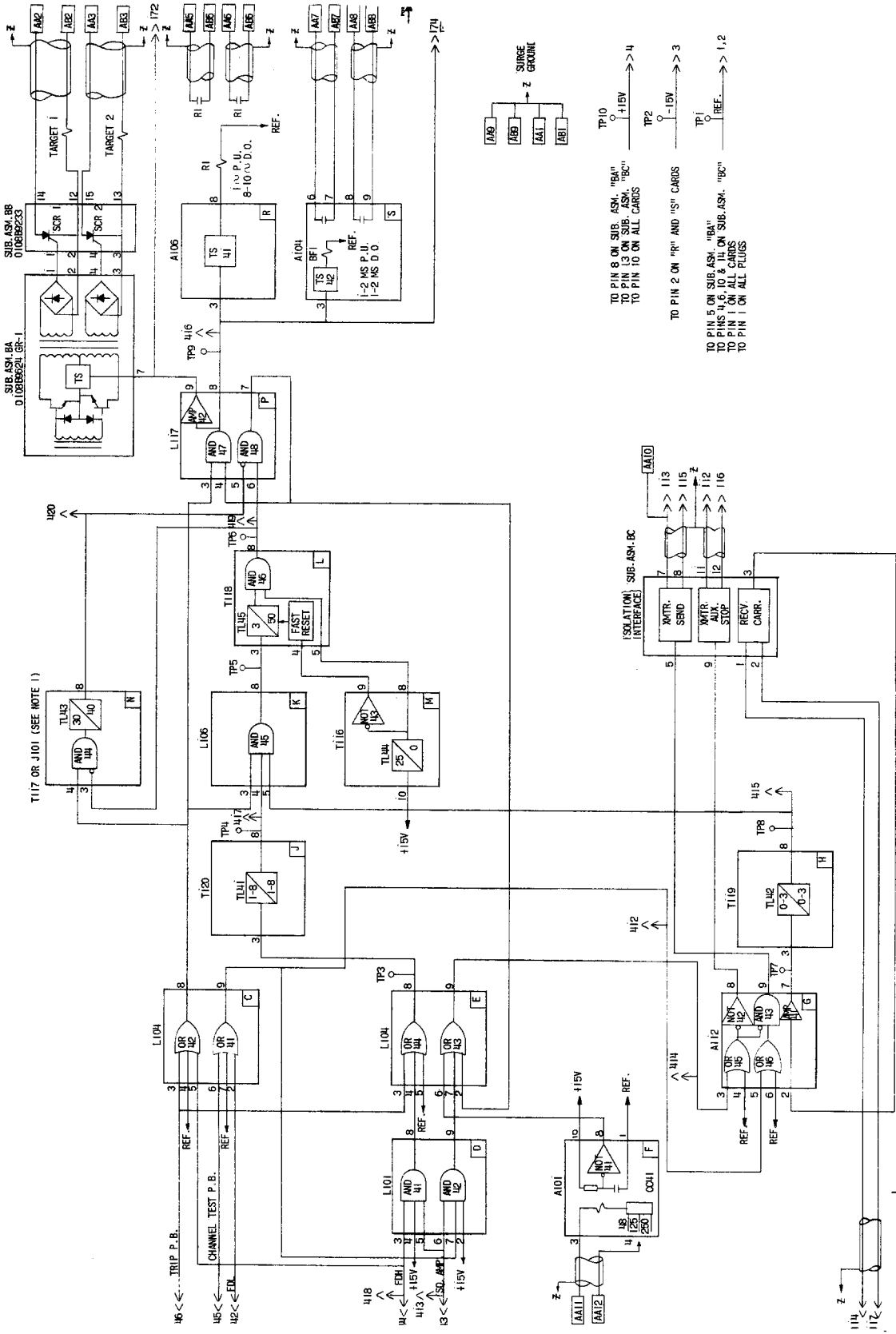
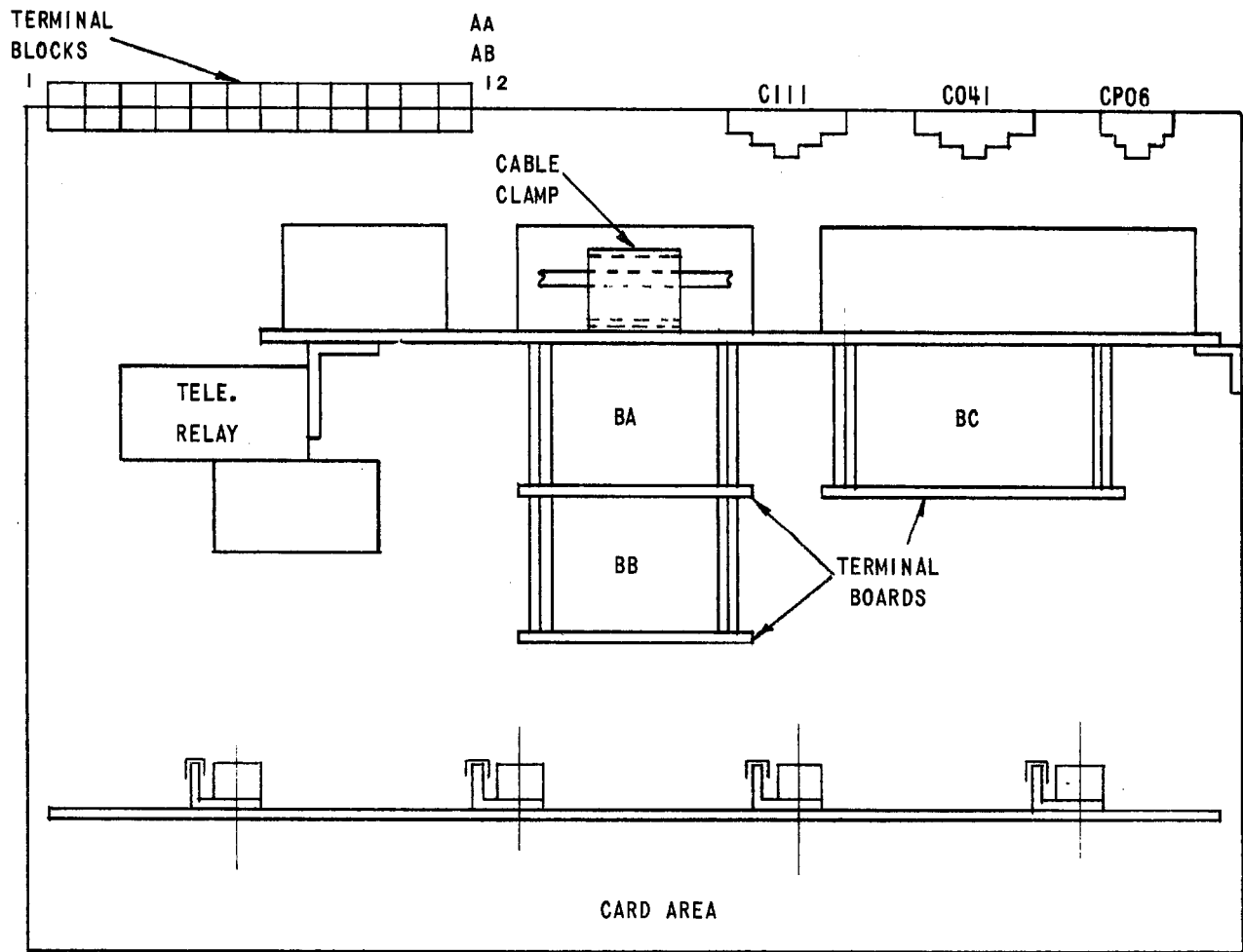

FIG. 2 (0149C7243-1) Internal Connections For The Type SLAT61A Relay



NOTE:  
 FOR SLAT61A1,2 USE P.C. CARD J101  
 FOR SLAT61A3,4 USE P.C. CARD T117

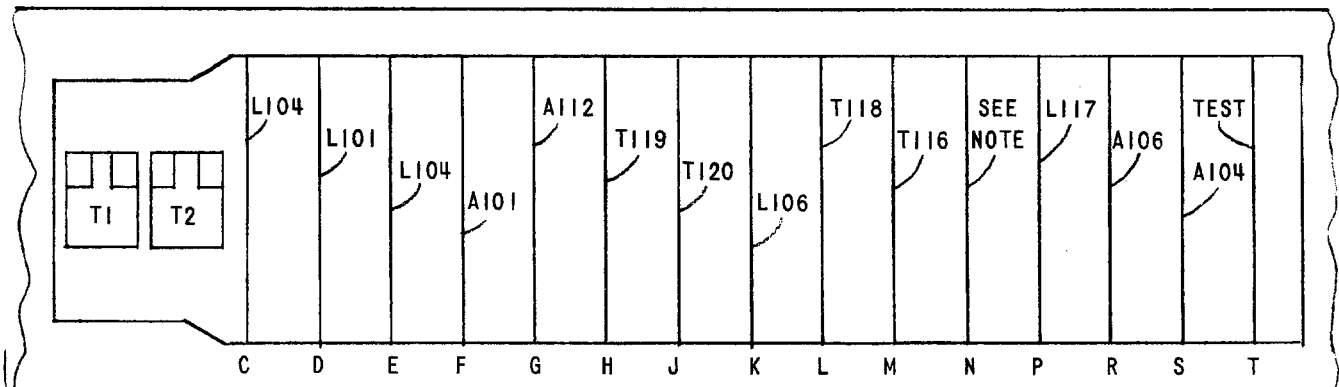
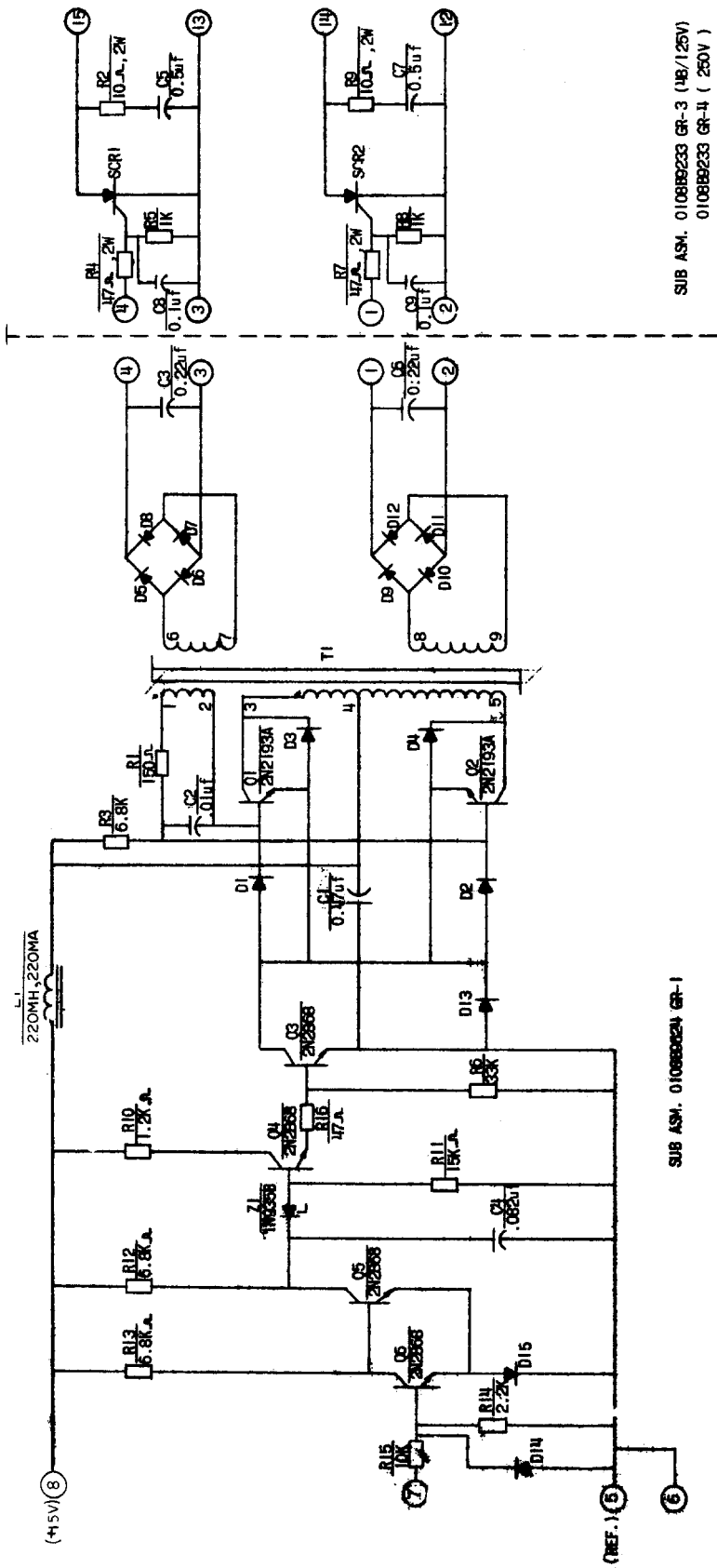

FIG. 3 (0246A6562-0) Component Locations For The Type SLAT61A Relay



SUB ASM. 0108B9610 GR-1

SUB ASM. 0108B9233 GR-3 (148/125V)  
0108B9233 GR-4 ( 250V )

ALL DIODES 1N4148 UNLESS NOTED  
ALL RES. 1/2 WATT ±5% UNLESS NOTED  
② = TERM. POST ON BOARD ASM  
1N4358 = 9.1V ±5%

FIG. 4 (0108B9610-0) Internal Connections For The SCR Trip And Isolator Subassemblies

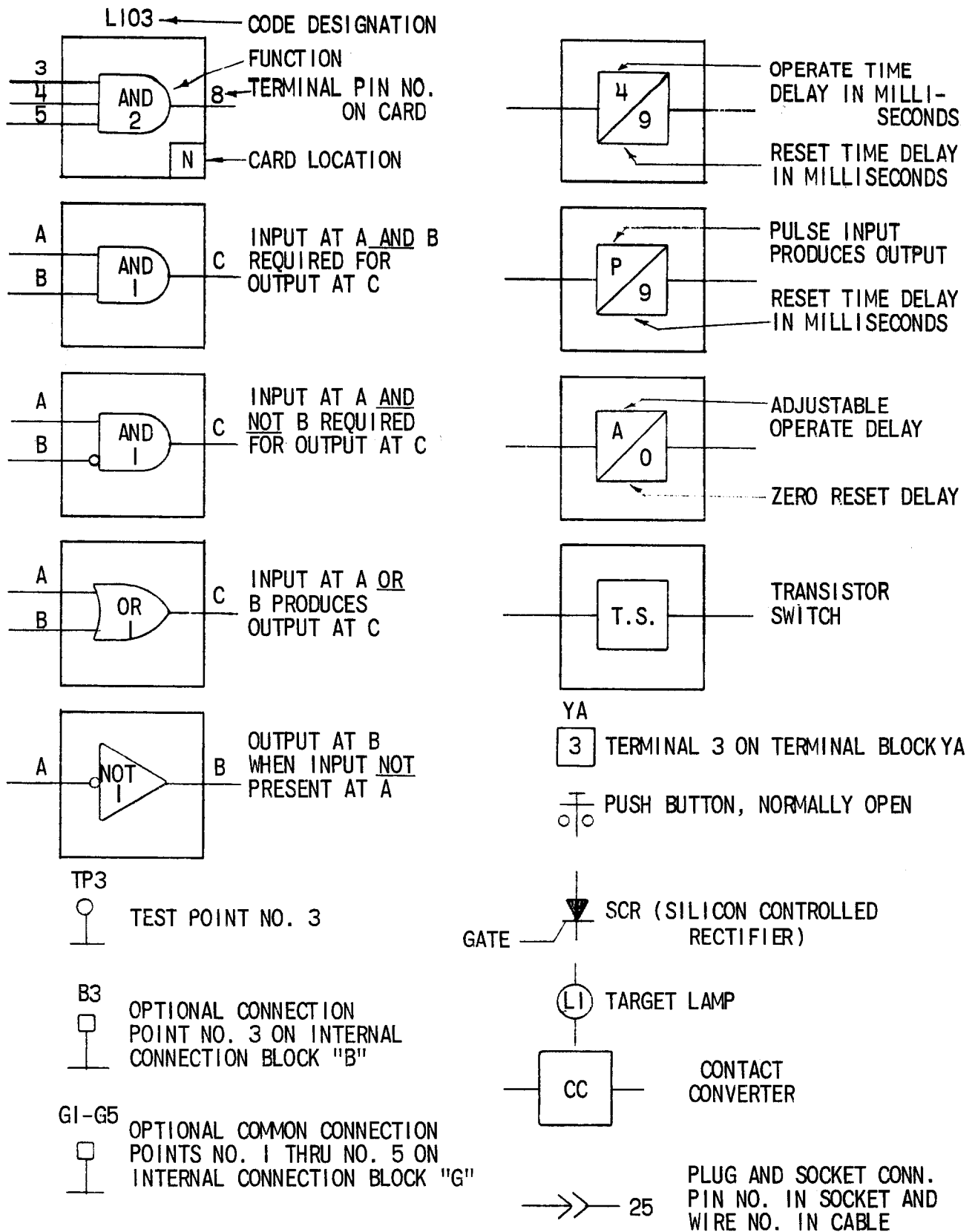

FIG. 5 (0227A2047-0) Logic And Internal Connection Diagram Legend

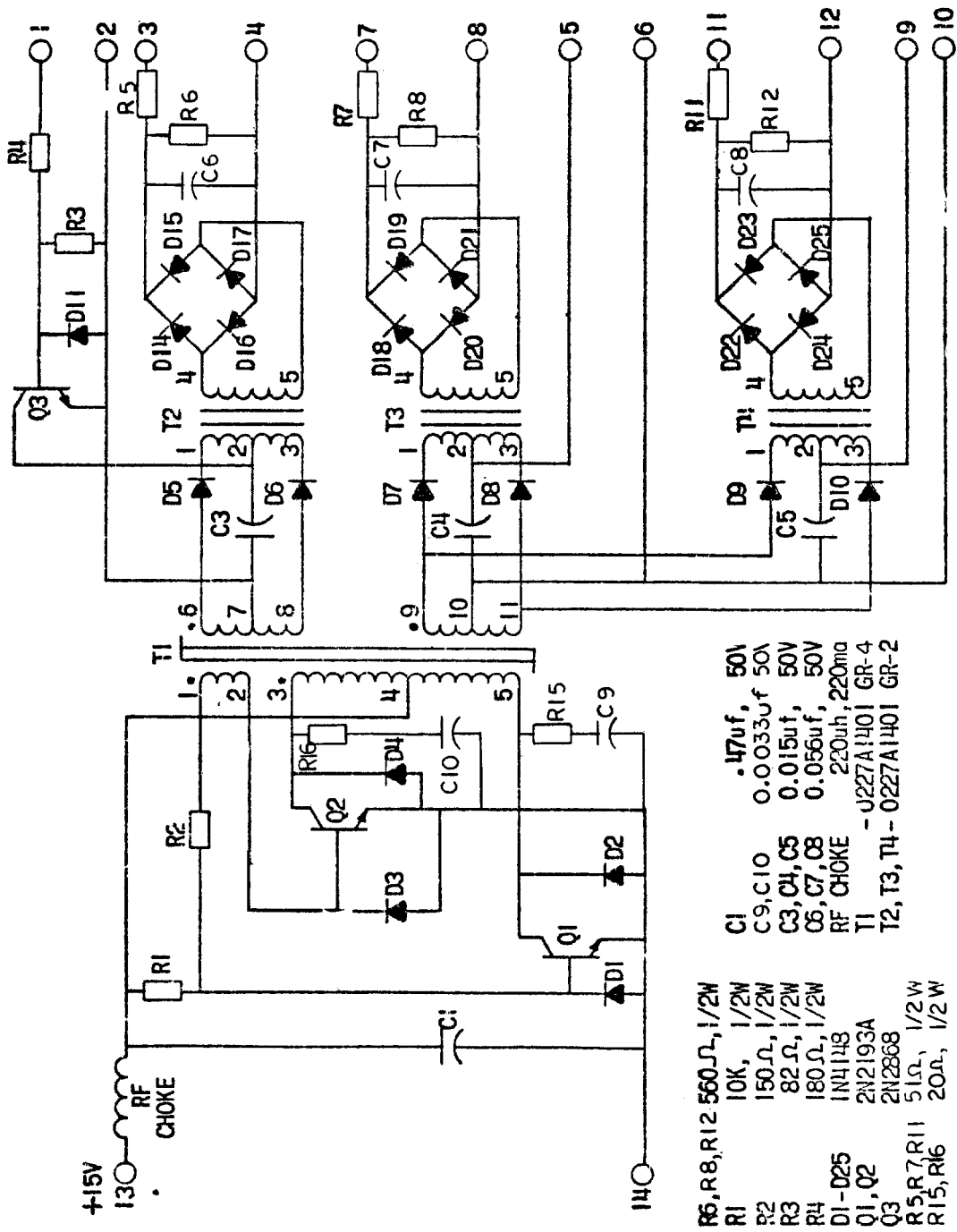
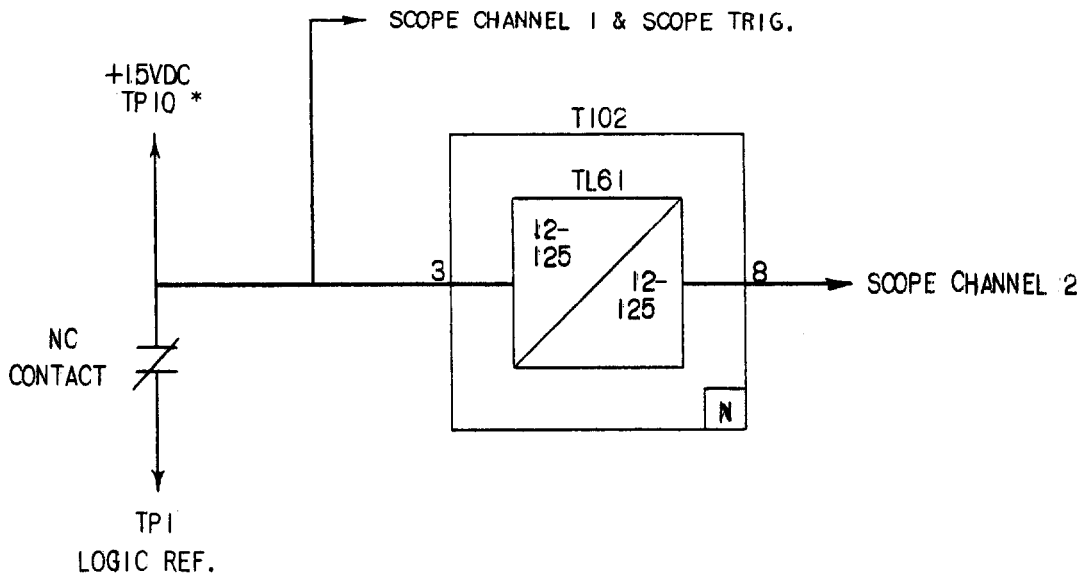

FIG. 6 (0208A5504AJ-1) Isolation Interface Circuit



\* THE 15VDC SIGNAL AT PIN 10 HAS A CURRENT LIMITING RESISTOR MOUNTED ON THE TEST CARD.

FIG. 7 (0246A7987-0) Logic Timer Test Circuit

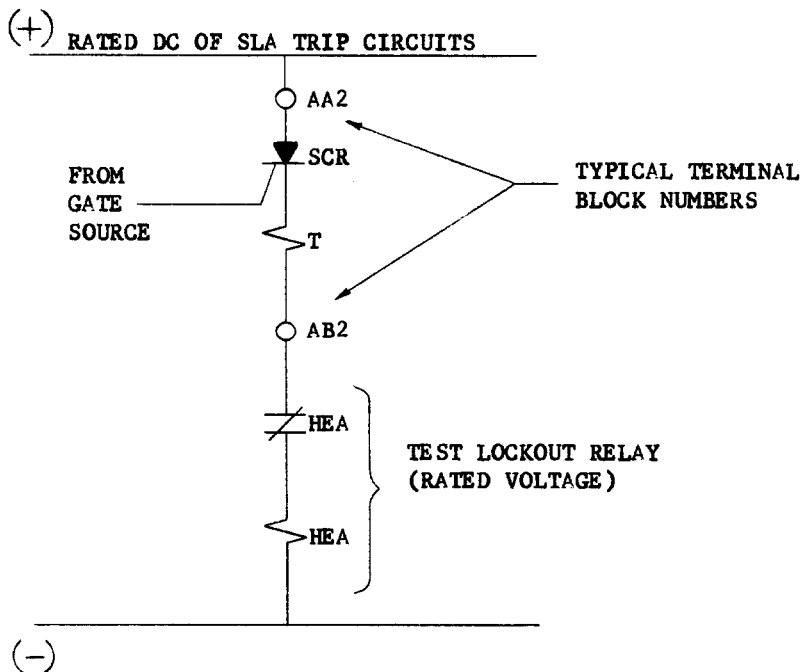

FIG. 7

TYPICAL SCR TEST CIRCUIT FOR TYPE SLA RELAYS

FIG. 8 (0208A2365-0) Typical SCR Trip Circuit Test Connections

**GENERAL ELECTRIC COMPANY  
POWER SYSTEMS MANAGEMENT BUSINESS DEPT.  
MALVERN, PA 19355**

**GENERAL  ELECTRIC**