



INSTRUCTIONS

GEK-45479A

SUPERSEDES GEK-45479

STATIC AND TRIPPING UNIT

TYPE SLAT54E

POWER SYSTEMS MANAGEMENT DEPARTMENT

GENERAL  ELECTRIC

PHILADELPHIA, PA.

CONTENTS

	<u>PAGE</u>
DESCRIPTION.....	3
APPLICATION.....	3
SETTINGS.....	3
RATINGS.....	3
BURDENS.....	4
FUNCTIONS.....	4
TRIP CIRCUIT.....	4
RI RECLOSE INITIATE CIRCUIT.....	4
RR32.....	4
RR33.....	4
RR34.....	4
VI - POSITIVE SEQUENCE VOLTAGE DETECTOR CIRCUIT.....	4
RR31.....	4
AUXILIARY REED RELAY OUTPUTS.....	4
CONTACT CONVERTERS.....	4
TL31 DC SUPERVISION TIMER.....	5
TARGETS.....	5
LOGIC CIRCUITS.....	5
CONSTRUCTION.....	5
RECEIVING, HANDLING AND STORAGE.....	5
TEST INSTRUCTIONS.....	6
GENERAL.....	6
OPERATIONAL CHECKS.....	6
TEST CARD ADAPTER.....	6
TIMER ADJUSTMENTS AND TESTS.....	6
OVERALL EQUIPMENT TESTS.....	6
MAINTENANCE.....	7
PERIODIC TESTS.....	7
TROUBLE SHOOTING.....	7
SPARE PARTS.....	7

STATIC OUTPUT AND TRIPPING UNITTYPE SLAT54EDESCRIPTION

The Type SLAT54E is a tripping and output unit providing two contact outputs for tripping either a single pole or three poles depending on the type of scheme in which it is used.

The target circuitry provides control output for control of lamps external to the unit. Provision is made for 7 double contact (isolated) outputs, 2 single contact outputs, and one three contact output. When supplied these contacts are normally used for reclosing initiation, breaker failure initiation, keying direct transfer trip channels, out-of-step trip keying, positive sequence voltage indication, and various data logging indications.

APPLICATION

When the SLAT54A is used with the type SLA52G auxiliary logic unit, the output contact can often be connected to various points in the logic circuit; thereby often providing the opportunity for bringing out the status of a point in the logic for special control or indication purposes.

SETTINGS

The setting of the TL32 timer when the TT contacts are used for keying a direct transfer trip channel should be sufficiently long to override the high noise levels generated when tripping the local breakers but sufficiently short so as not to interfere with high speed reclosing at the remote terminal. A typical setting would be 100 to 125 ms.

RATINGS

The Type SLAT54E relay is designed for use in an environment where the ambient temperature around the relay case is between -20°C and +65°C.

The Type SLAT54E relay requires a +15VDC power source which can be obtained from a Type SSA50/51 power supply.

The tripping contacts will make and carry 3 amperes continuously or short time. The contacts will interrupt 100 VA resistive (35 VA inductive). Each has a 1.0 ampere series target.

The contacts of the telephone type relays will make and carry 3 amperes continuously and will interrupt up to 180 volt-amperes resistive (60 VA inductive). The contacts will make and carry 30 amperes for 1 second.

The contacts of the OST, RC&BFI reed relays will make and carry 3 amperes for tripping duty and is continuously rated for 3 amperes. The contacts will interrupt 100 volt-amperes resistive (35 VA inductive).

The contacts of the reed relays that are used for TT, RR38, RR39, RR40 & RR41 relays are rated for 10 volt-amperes. They will carry 0.5 ampere continuously.

Each contact converter in this relay has a link for selecting the proper voltage for the coil circuit of the contact converter. The available voltage taps are for 48, 125, or 250 VDC.

Refer to the unit nameplate for the trip circuit rating of a particular relay.

These instructions do not purport to cover all details or variations in equipment nor to provide for every possible contingency to be met in connection with installation, operation or maintenance. Should further information be desired or should particular problems arise which are not covered sufficiently for the purchaser's purposes, the matter should be referred to the General Electric Company.

To the extent required the products herein meet applicable ANSI, IEEE and NEMA standards; but no such assurance is given with respect to local codes and ordinances because they vary greatly.

BURDENS

The SLAT54E relay presents a maximum burden to the Type SSA power supply of:

100 ma from the + 15 VDC supply

400 ma from the - 15 VDC supply

FUNCTIONSA. TRIP CIRCUIT

Electrically separate, isolated trip contacts are provided to trip two breakers. Each circuit is capable of carrying 3 amperes. These contacts operate within 2 ms of the time the associated coil is energized.

B. RI RECLOSE INITIATE CIRCUIT

Two electrically separate normally open contacts are provided. These contacts close within 17 ms from the time the associated coil is energized by the logic. The contacts open within 170 ms from the time, the coil is deenergized. The RI functions use a telephone type relay with contact ratings stated under RATINGS.

C. RR32

Two electrically separate normally open contacts are provided. These contacts close within 2 ms from the time the associated coil is energized by the logic. These contacts open within 2 ms from the time the coil is deenergized. RR32 uses a reed relay with contact ratings stated under RATINGS.

D. RR33

Two electrically separate normally open contact are provided. These contacts close within 2 ms from the time the associated coil is energized by the logic. They open within 2 ms from the time the coil is deenergized. RR33 uses a reed relay with contact ratings stated under RATINGS.

E. RR34

Two electrically separate normally open contacts are provided. These contacts operate within 2 ms from the time the associated coil is energized by the logic. They reset within 2 ms. from the time the coil is deenergized. RR34 uses a reed relay with contact ratings stated under RATINGS.

F. VI - POSITIVE SEQUENCE VOLTAGE DETECTOR CIRCUIT

Three electrically separate contacts are provided, two normally open and one normally closed. These contacts operate within 17 ms from the time the associated coil is energized by the logic. They reset within 17 ms from the time the coil is deenergized. The VI function uses a telephone type relay with contact ratings stated under RATINGS.

G. RR31

Two electrically separate normally open contacts are provided. These contacts close within 0.5 ms from the time the associated coil is energized by the logic. They open within 0.5 ms from the time the coil is deenergized. RR31 uses a reed relay with contact ratings stated under RATINGS.

H. AUXILIARY REED RELAY OUTPUTS

The usage of these reed relay outputs is determined by the particular scheme in which the SLAT54E is employed. RR38 and RR41 each have two electrically separate contacts. RR39 and RR40 each have one contact. The ratings of the contacts of these reeds are stated under RATINGS.

I. CONTACT CONVERTERS

The purpose of the contact converters (CC31, CC32) included in the Type SLAT54E relay is to convert a contact operation into a signal that is compatible with the logic circuitry of the relay.

When the external contact associated with CC31 operates, the seal-in circuit of the target contacts is interrupted

When the external contact associated with CC32 operates, the output relays are blocked from operation.

J. TL31 DC SUPERVISION TIMER

TL31 is a non-adjustable timer (25/0) that provides DC supervision of relay logic circuits. When DC is removed, TL31 will prevent any trip outputs until 25 ms after DC has been reestablished. NOT 31 provides a fast reset signal to all timers with reset times longer than 25 ms that could produce a spurious trip output upon removal of DC.

TARGETS

Two electromechanical target coils are included, one in series with each trip contact. These targets operate on one ampere of trip current. The trip circuit resistance in the relay is 0.40 ohm.

Six contacts are included in the SLAT54E for remote target indication. These contacts are all supervised by the trip bus and can be used to indicate what functions in the relaying scheme operated to cause the trip. The inputs which drive the target contacts will be shown on the associated overall logic. These contacts have the same ratings as RR38-RR41.

LOGIC CIRCUITS

The functions of the Type SLAT54E relay involve basic logic (AND, OR AND NOT) where the presence or absence of signals, rather than their magnitude, controls the operation. Signals are measured with respect to a reference bus accessible at TP1. In general a signal below 1 VDC represents an OFF or LOGIC ZERO condition, an ON or LOGIC ONE state is represented by a signal of approximately ± 15 VDC.

The symbols used on the internal connection diagram (Fig. 1) are explained by the legend shown in Figure 2.

CONSTRUCTION

The SLAT54E relay is packaged in an enclosed metal case with hinged front cover and removable top cover. The outline and mounting dimensions of the case and the physical location of the components are shown in Figures 3 and 4 respectively.

The SLAT54E relay contains printed circuit cards identified by a code number such as: A110, T114, L102, where A designated an auxiliary function, T designated a time delay function, and L designated a logical function. The printed circuit cards plug in from the front of the unit. The sockets are marked with letter designations or "addresses" (D, E, F, etc.) which appear on the guide strips in front of each socket, on the component location drawing, on the unit internal connection diagram and on the printed circuit card. The test points (TP1, TP2, etc.) shown on the internal connection diagram are connected to instrument jacks on a test card in position T or AT with TP1 at the top of the AT card. TP1 and TP11 are tied to reference; TP10 and TP20 are tied to +15 VDC through a 1.5K resistor. This resistor limits the current when TP10 or TP20 is used to supply a logic signal to a card.

The SLAT54E relay receives its inputs from the associated Type SLA relay. These units are interconnected by ten conductor shielded cables. The sockets for these cables are located on the rear panel of the unit. The SLAT54E output functions are connected to 12 point terminal strips, which are also located on the rear of the unit.

A window is provided in the hinged cover of the relay to allow the mechanical targets to be seen. A push button is also provided to reset the EM targets and the target contacts without opening the cover.

RECEIVING, HANDLING AND STORAGE

These relays will normally be supplied as a part of a static relay equipment, mounted in a rack or cabinet with other static relays and test equipment. Immediately upon receipt of a static relay equipment, it should be unpacked and examined for any damage sustained in transit. If injury or damage resulting from rough handling is evident, file a damage claim at once with the transportation company and promptly notify the nearest General Electric Sales Office.

Reasonable care should be exercised in unpacking the equipment. If the equipment is not to be installed immediately, it should be stored indoors in a location that is free from moisture, dust, metallic chips, and severe atmospheric contaminants.

Just prior to final installation the shipping support bolt should be removed from each side of all relay units, to facilitate possible future unit removal for maintenance. These shipping support bolts are approximately 8 inches back from the relay front panel. Static relay equipment, when supplied in swing rack cabinets, should be securely anchored to the floor or to the shipping pallet to prevent the equipment from tipping over when the swing rack is opened.

TEST INSTRUCTIONS

If the SLAT54E relay that is to be tested is installed in an equipment which has already been connected to the power system, disconnect the outputs to the system.

CAUTION

THE LOGIC SYSTEM SIDE OF THE DC POWER SUPPLY USED WITH MOD III STATIC RELAY EQUIPMENT IS ISOLATED FROM GROUND. IT IS A DESIGN CHARACTERISTIC OF MOST ELECTRONIC INSTRUMENTS THAT ONE OF THE SIGNAL INPUT TERMINALS IS CONNECTED TO INSTRUMENT CHASSIS. IF THE INSTRUMENT USED TO TEST THE RELAY EQUIPMENT IS ISOLATED FROM GROUND, ITS CHASSIS MAY HAVE AN ELECTRICAL POTENTIAL WITH RESPECT TO GROUND. THE USE OF A TEST INSTRUMENT WITH A GROUNDED CHASSIS WILL NOT AFFECT THE TESTING OF THE EQUIPMENT. A SECOND GROUND CONNECTION TO THE EQUIPMENT, SUCH AS A TEST LEAD INADVERTENTLY DROPPING AGAINST THE RELAY CASE, MAY CAUSE DAMAGE TO THE LOGIC CIRCUITRY. NO EXTERNAL TEST EQUIPMENT SHOULD BE LEFT CONNECTED TO THE STATIC RELAYS WHEN THEY ARE IN PROTECTIVE SERVICE, SINCE TEST EQUIPMENT GROUNDING REDUCES THE EFFECTIVENESS OF THE ISOLATION PROVIDED.

A. GENERAL

The SLAT54E relay is supplied from the factory either mounted in a static relay equipment or as a separate unit associated with measuring relays, a Type SSA power supply, and some form of channel equipment. All relay units for a given terminal of static relaying equipment are tested together at the factory, and each unit will have the same summary number stamped on its nameplate.

Timers should be set for the operating and reset times indicated on the associated overall logic diagram. Where a time range is indicated on the overall logic diagram, the timer should be set for the value recommended for that function in the descriptive writeup accompanying the overall logic diagram. Where a setting depends upon conditions encountered on a specific application, this is so stated and the factors influencing the choice of setting are described. The procedure for checking and setting the timers is described in a later section.

B. OPERATIONAL CHECKS

Operation of the SLAT54E unit can be checked by observing the signals at the twenty test points (TP1 to TP20) in the SLAT54E by observing the operation of the associated channel equipment, or by observing the output functions. The test points are located on two test cards in positions T and AT, and are numbered 1 to 20 from top to bottom. TP1 is the reference bus for the logic circuit, TP10 is at +15 VDC. The remaining points are located at various strategic points throughout the logic as shown on the internal connection diagram (Figure 1). Test point voltages can be monitored with a portable high impedance voltmeter, the voltmeter on the test panel of the associated equipment, or an oscilloscope.

Operation of any logic function may be checked by supplying the correct inputs to the card. This is accomplished by placing the card under test in a card extender, removing the cards which normally supply the input signals, and then connecting the card inputs to either TP10 or TP1. An output should be produced when the proper combination of inputs is supplied to the card.

C. TEST CARD ADAPTER

The test card adapter provides a convenient means of gaining access to any pin of a particular card. Detailed information on the use of the test adapter card is included in the card instruction book GEK-34158.

D. TIMER ADJUSTMENTS AND TESTS

When the time delay cards are to be adjusted or checked, an oscilloscope that can display two traces simultaneously and that has a calibrated horizontal sweep should be used.

In order to test the timer cards it is necessary to remove the card which supplied the input to the timer and to place the timer card in a card adapter. The card adapter allows access to the input and output of the timer if they are not brought out on test points. The timer test circuit is shown on Fig. 6. Opening the N.C. contact causes the output to step up to +15 VDC after the pickup delay of the timer. To increase the pickup time, turn the upper potentiometer on the timer card clockwise; to decrease the time turn it counterclockwise. Closing the contact causes the timer output to drop out after the reset time delay, it can be adjusted by the lower potentiometer on the timer card (CW increases reset time).

E. OVERALL EQUIPMENT TESTS

After the SLAT54E relay and the associated static relay units have been individually calibrated and tested for the desired settings, a series of overall operating circuit checks is advisable.

The elementary overall logic, and logic description for the specific job will be useful for determining the overall operation of the scheme.

Overall equipment tests can be performed by applying AC current and voltages to the measuring units as specified in the instruction book for the measuring units and checking that proper outputs are obtained when the measuring units operate.

MAINTENANCE

A. PERIODIC TESTS

It should be sufficient to check the outputs produced at test points in the SLAT54E where periodic calibration tests are made on the associated measuring units, for example, the phase and ground relays in line relaying scheme. No separate periodic tests on the SLAT54E itself should be required.

B. TROUBLE SHOOTING

In any trouble shooting of equipment, it should first be established which unit is functioning incorrectly. The overall logic diagram supplied with the equipment shows the combined logic of the complete equipment and the various test points in each unit. By signal tracing, using the overall logic diagram and the various test points, it should be possible to quickly isolate the trouble.

A test adapter card is supplied with each static relay equipment to supplement the prewired test points on the test cards. Use of the adapter card is described in the card instruction book GEK-34158.

A dual-trace oscilloscope is a valuable aid to detailed trouble shooting, since it can be used to determine phase shift, operate and reset times as well as input and output levels. A portable dual-trace oscilloscope with a calibrated sweep and trigger facility is recommended.

C. SPARE PARTS

To minimize possible outage time, it is recommended that a complete maintenance program should include the stocking of at least one spare card of each type. It is possible to replace damaged or defective components on the printed circuit cards, but great care should be taken in soldering so as not to damage or bridge-over the printed circuit busses, or overheat the semi-conductor components. The repaired area should be recovered with a suitable high-dielectric plastic coating to prevent possible breakdowns across the printed busses due to moisture and dust. The wiring diagrams for the cards in the SLAT54E relay are included in the card book GEK-34158.

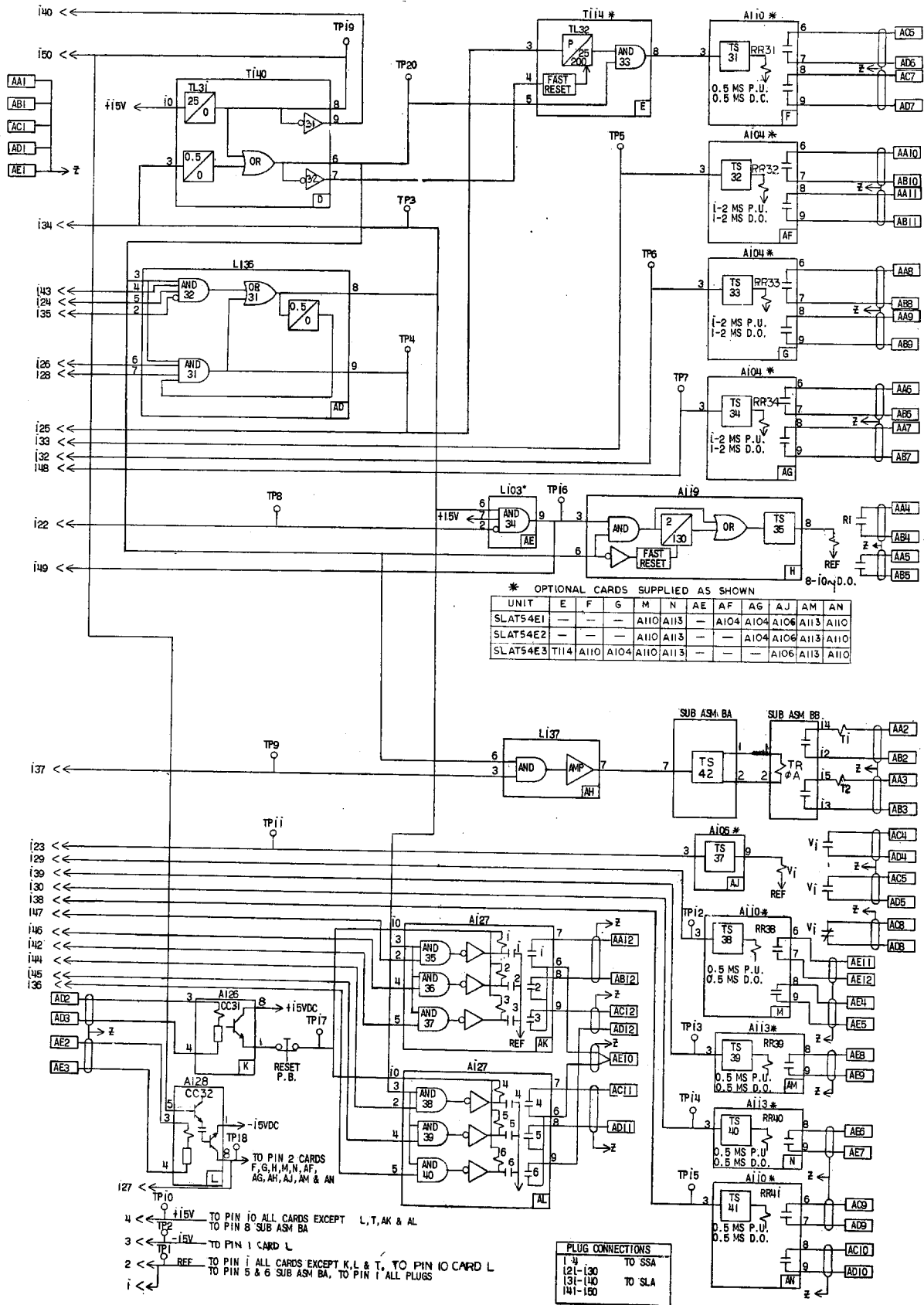

Fig. 1 (0171C7852-2) Internal Connections Diagrams for the Type SLAT54E Relay

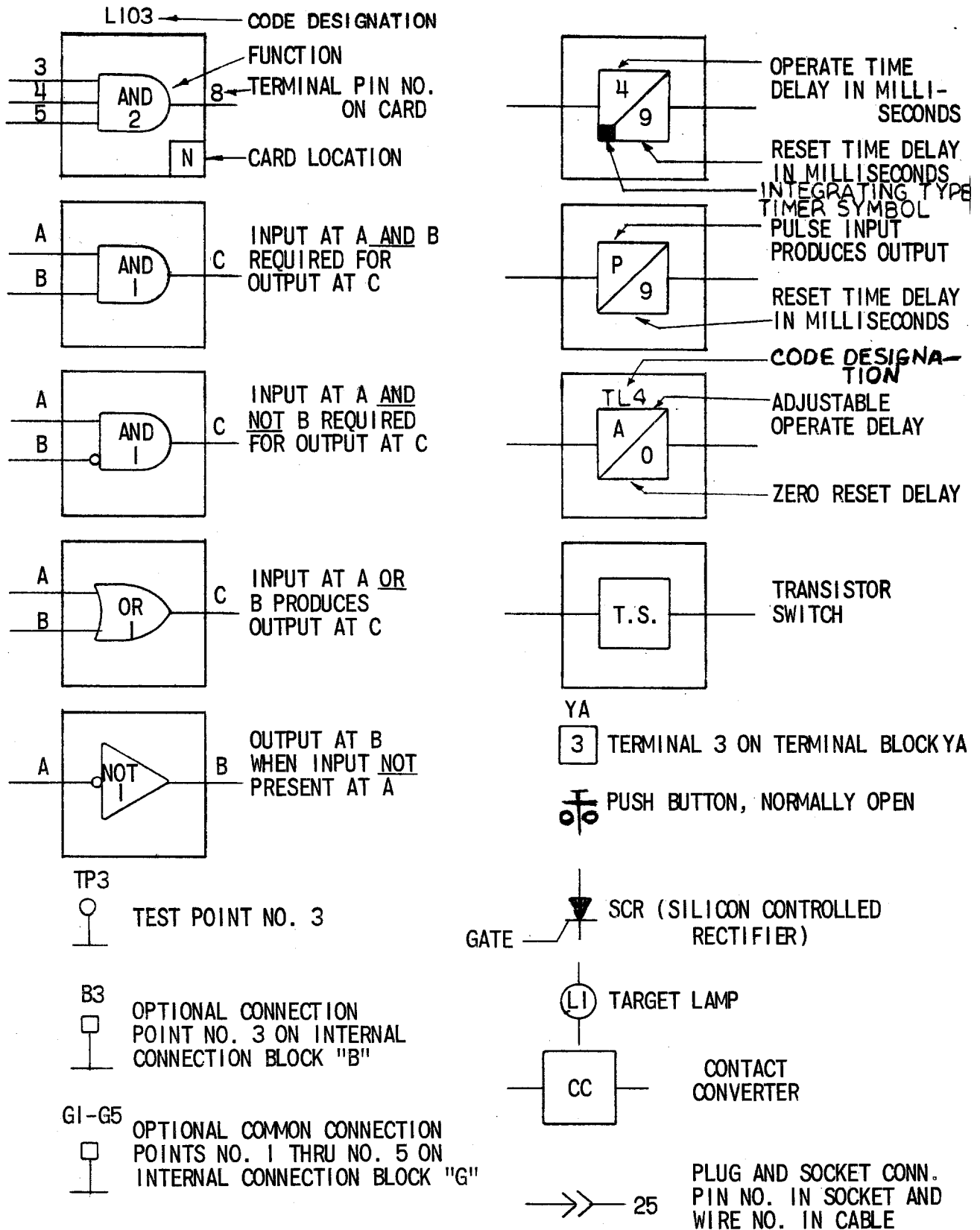

Figure 2 (0227A2047-0) Internal Connection Diagram Legend

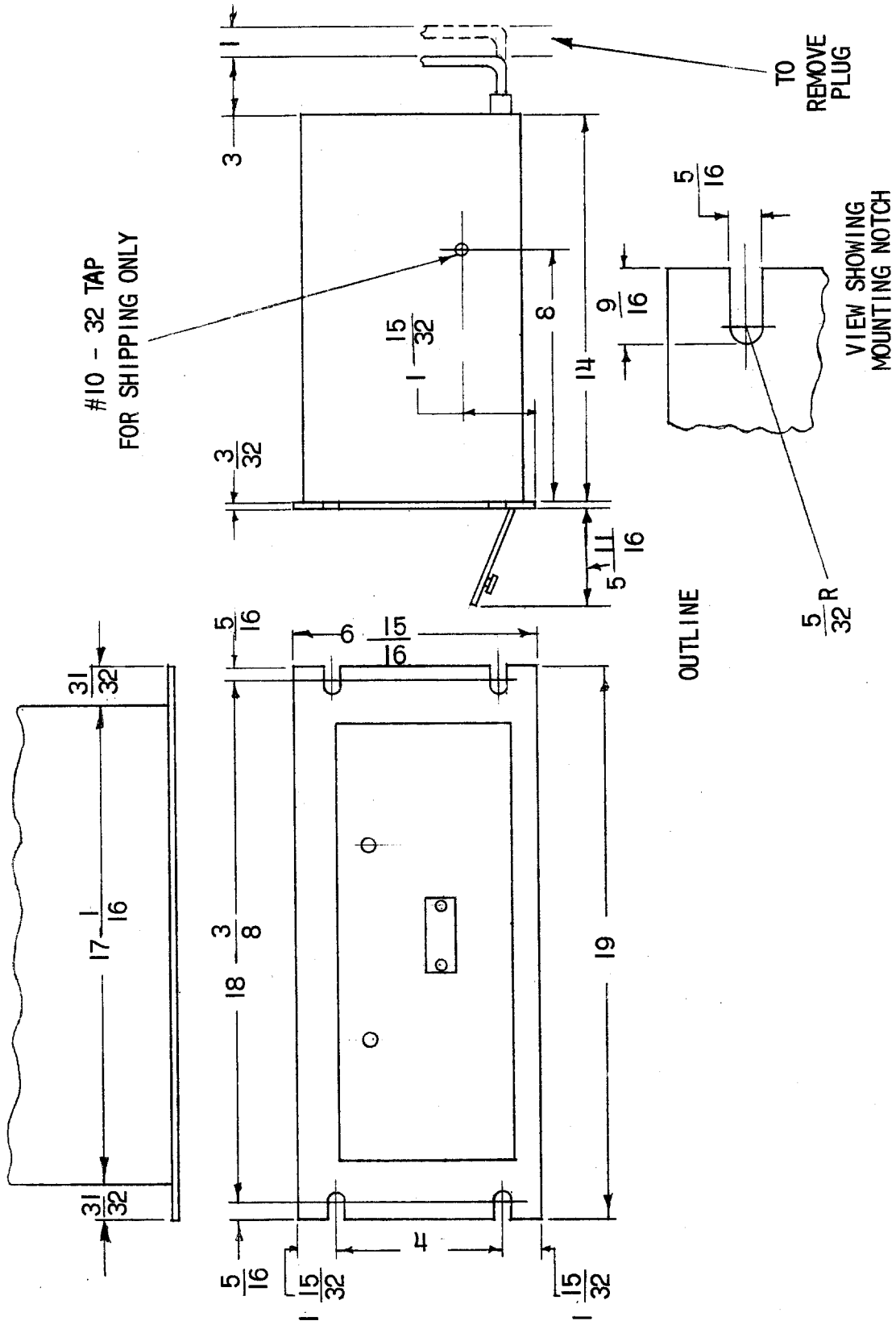
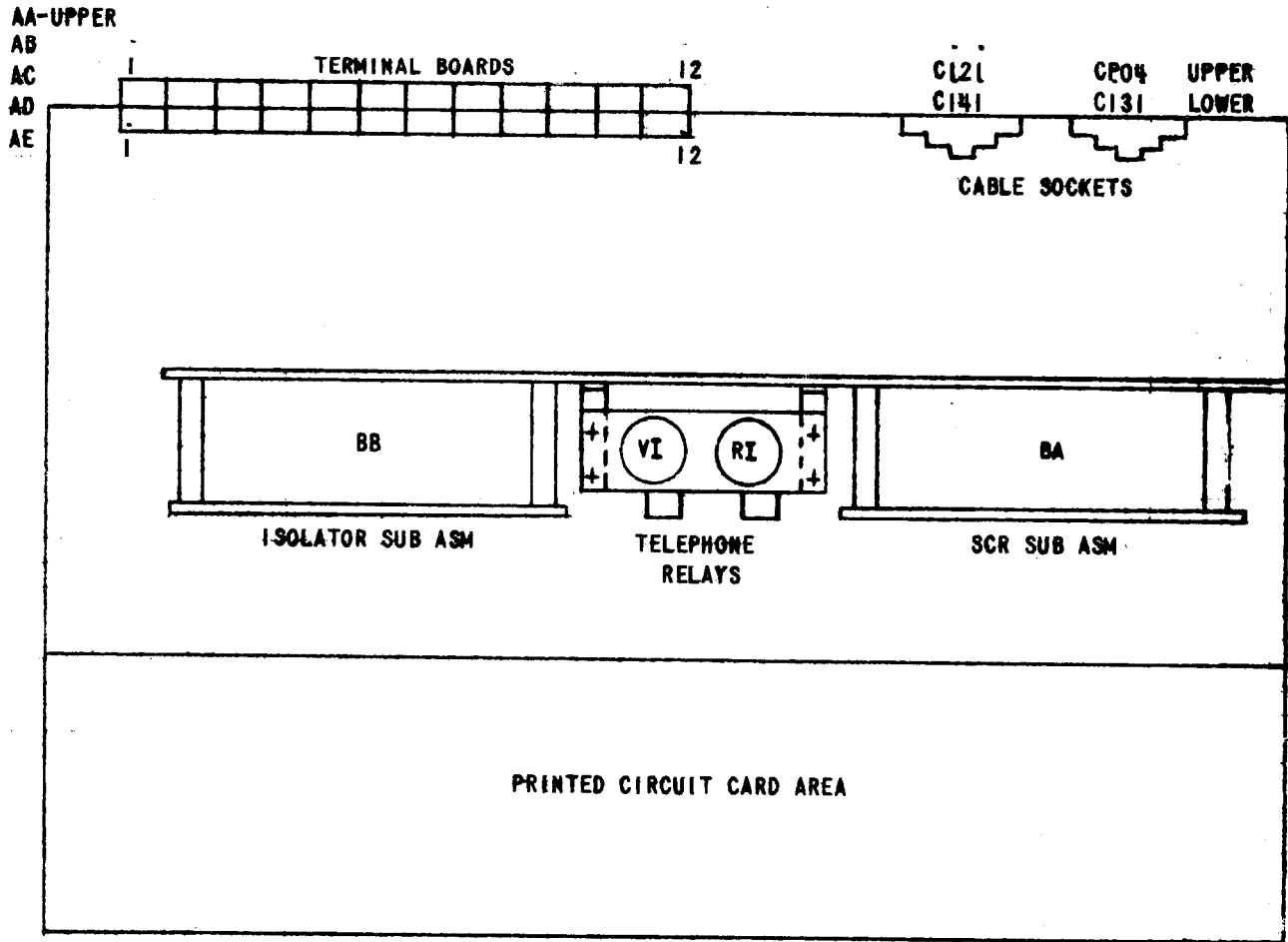

Figure 3 (0227A2037-0) Outline and Mounting Dimensions for the Type SLAT54E Relay



TOP VIEW

(COVER REMOVED)

FRONT

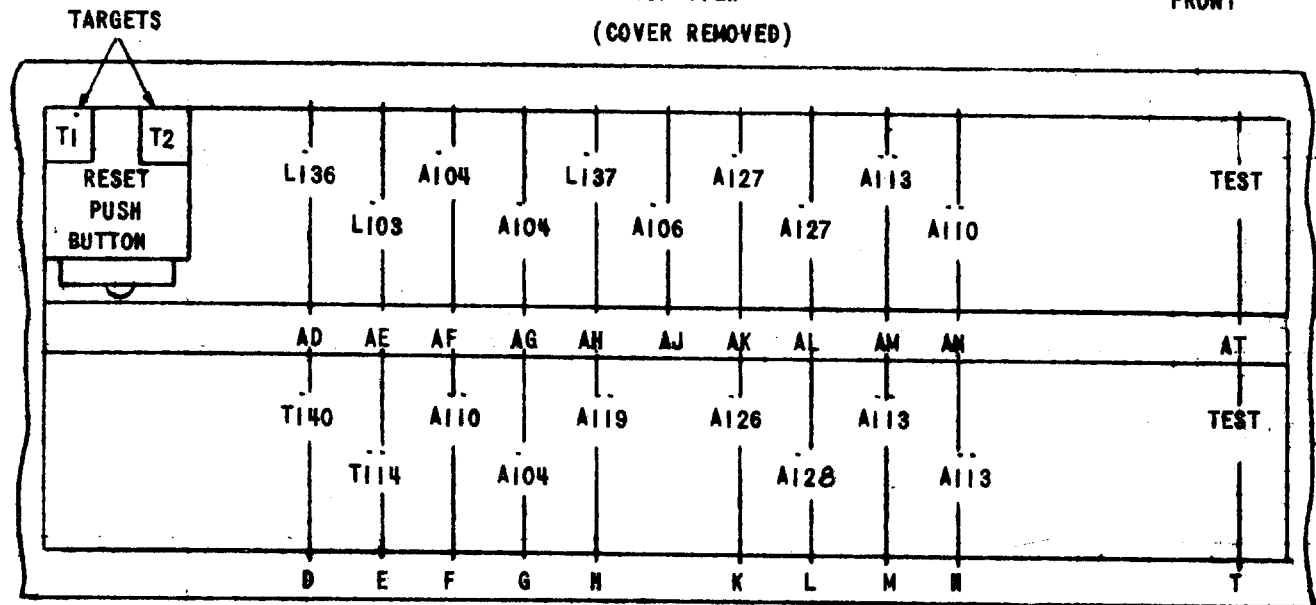

FRONT VIEW

(COVER REMOVED)

Fig. 4 (0257A8775-0) Component and Card Locations for the Type SLAT54E Relay

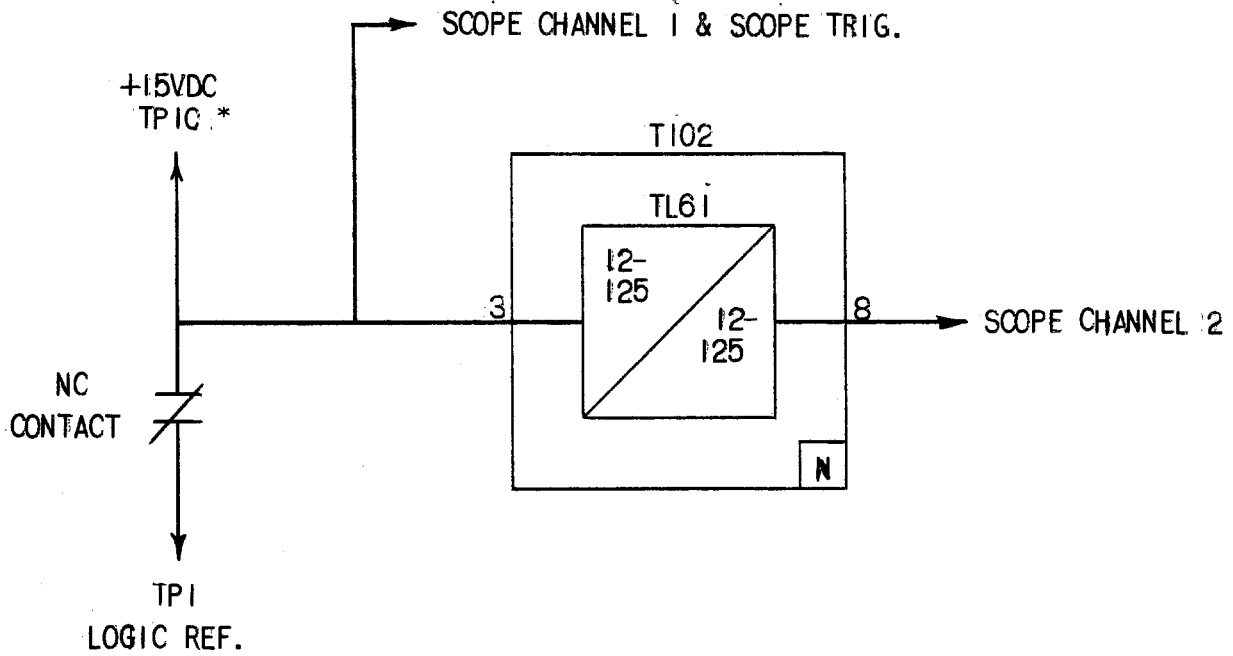

* THE 15VDC SIGNAL AT PIN 10 HAS A CURRENT LIMITING RESISTOR MOUNTED ON THE TEST CARD.

Fig. 5 (0246A7987-0) Logic Timer Test Circuit