



# INSTRUCTIONS

GEK-49783

---

STATIC OUTPUT AND TRIPPING UNIT

TYPE SLAT54G

---

**POWER SYSTEMS MANAGEMENT DEPARTMENT**

**GENERAL  ELECTRIC**

**PHILADELPHIA PA**

CONTENTS

	PAGE
DESCRIPTION .....	3
APPLICATION .....	3
RATINGS .....	3
BURDENS .....	4
FUNCTIONS .....	4
A. TRIP CIRCUIT .....	4
B. RI RECLOSE INITIATE CIRCUIT .....	4
C. BFI BREAKER FAILURE INITIATE CIRCUIT .....	4
D. OST OUT-OF-STEP TRIP CIRCUIT .....	4
E. RC RECLOSE CANCELLATION CIRCUIT .....	4
F. VI-POSITIVE SEQUENCE VOLTAGE DETECTOR CIRCUIT .....	5
G. TT-TRANSFER TRIP CIRCUIT .....	5
H. TXA-TRANSMITTER KEYING AUXILIARY .....	5
I. DLA-DATA LOGGING AMPLIFIER CONTACTS .....	5
TARGETS .....	5
LOGIC CIRCUITS .....	5
CALCULATION OF SETTINGS .....	5
CONSTRUCTION .....	6
RECEIVING, HANDLING AND STORAGE .....	6
TEST INSTRUCTIONS .....	6
CAUTION .....	6
A. GENERAL .....	7
B. OPERATIONAL CHECKS .....	7
C. TEST CARD ADAPTER .....	7
D. TIMER ADJUSTMENTS AND TESTS .....	7
TABLE I .....	7
E. TRIP CIRCUIT TESTS .....	7
TABLE II .....	8
F. OVERALL EQUIPMENT TESTS .....	8
MAINTENANCE .....	8
A. PERIODIC TESTS .....	8
B. TROUBLESHOOTING .....	8
C. SPARE PARTS .....	8

## STATIC OUTPUT AND TRIPPING UNIT

## TYPE SLAT 54G

DESCRIPTION

The Type SLAT54G relay is a static output and tripping unit. This relay is not intended to be used by itself, but rather as part of a complement of equipment that forms a protective relaying scheme. For a complete description of the overall scheme in which this relay is employed, refer to the overall logic diagram and its associated logic description that is supplied with each terminal of equipment.

The Type SLAT54G relay is packaged in a four rack unit (1 R.U. = 1 3/4 inches) enclosed metal case suitable for mounting on a 19 inch rack. The outline and mounting dimensions are shown in Fig. 1. The internal connections for the relay are shown in Fig. 2. The component and card locations are shown in Fig. 3.

APPLICATION

The Type SLAT54G relay was originally designed to operate in conjunction with Type SLYP, Type SLCN, Type SLC, Type SLA, and Type SSA relays in a directional comparison scheme for series compensated lines. The following is a listing of the various output functions together with a general description of their intended uses.

- TR - The tripping circuit includes a single relay with two separate normally open contacts which are in series with mechanical target coils.
- RI - The reclose initiation outputs are provided to initiate automatic reclosing after a high speed trip-out.
- RC - The reclose cancellation outputs are provided to prevent high speed reclosing following a severe internal fault.
- BFI - The breaker failure initiation outputs are provided for breaker failure protection.
- OST - The out-of-step tripping outputs provide isolated trip capability following detection of an out-of-step condition.
- VI - The positive sequence voltage detector outputs are provided to permit bypassing the RC contacts to allow sequential reclosing.
- TT - The transfer trip outputs are provided to key a transfer trip transmitter when an output is present at the trip bus.
- TXA - The transmitter keying auxiliary outputs are provided for use in supervising a channel check-back circuit used with the associated direct transfer trip channel.
- DLA - Three data logging amplifier outputs are provided to monitor the trip, block and receiver output signals from within the associated SLA.

If any of these functions are not required, the outputs may be used for whatever purposes their characteristics are suited. All of these functions may not be included in all applications. Refer to the overall logic diagram supplied with each terminal to determine which functions have been included.

RATINGS

The Type SLAT54G relay is designed for use in an environment where the air temperature outside the relay case is between -20°C and +65°C.

This relay requires a ±15 VDC power source which can be obtained from a Type SSA power supply.

*These instructions do not purport to cover all details or variations in equipment nor to provide for every possible contingency to be met in connection with installation, operation or maintenance. Should further information be desired or should particular problems arise which are not covered sufficiently for the purchaser's purposes, the matter should be referred to the General Electric Company.*

*To the extent required the products described herein meet applicable ANSI, IEEE and NEMA standards; but no such assurance is given with respect to local codes and ordinances because they vary greatly.*

The contracts of the telephone-type relays that are used for TR, VI, and RI will make and carry three amperes continuously and will interrupt up to 0.5 ampere (inductive) at 125 VDC or 0.25 ampere (inductive) at 250 VDC. See Table II for additional ratings.

The contacts of the reed relays that are used for BFI, OST, and RC are rated for 100 watts direct current. They will make and carry 3.0 amperes continuously.

The contacts of the reed relays that are used for the TT, TXA, and DLA functions are rated for 10 volt amperes. They will carry 0.5 ampere (resistive) continuously.

Refer to the unit nameplate for the ratings of a particular relay.

#### BURDENS

The SLAT54G relay presents a maximum burden to the Type SSA power supply of:

90 ma from the +15 VDC supply  
350 ma from the -15 VDC supply

In addition, each target lamp draws 80 milliamperes from the -15 VDC supply.

#### FUNCTIONS

##### A. TRIP CIRCUIT

There are two electrically separate, normally open trip circuits. In addition, there is an electro-mechanical target which indicates trip current was passed by the associated trip contact. The contact outputs permit isolating the relay power supply from the trip circuit power supply.

##### B. RI RECLOSE INITIATE CIRCUIT

Two electrically separate normally open contacts are provided. These contacts close within 17 milliseconds from the time the associated coil is energized by the logic. The contacts open within 170 milliseconds from the time the coil is deenergized. The RI function uses a telephone-type relay with contact ratings stated under RATINGS.

##### C. BFI BREAKER FAILURE INITIATE CIRCUIT

Two electrically separate normally open contacts are provided. These contacts close within 2 milliseconds from the time the associated coil is energized by the logic. These contacts open within 2 milliseconds from the time the coil is deenergized. The BFI function uses a reed relay with contact ratings stated under RATINGS.

##### D. OST OUT-OF-STEP TRIP CIRCUIT

Two electrically separate normally open contacts are provided. These contacts close within 2 milliseconds from the time the associated coil is energized by the logic. They open within 2 milliseconds from the time the coil is deenergized. The OST function uses a reed relay with contact ratings stated under RATINGS.

##### E. RC RECLOSE CANCELLATION CIRCUIT

Four electrically separate contacts are provided, two normally open and two normally closed. These contacts operate within 2 milliseconds from the time the associated coil is energized by the logic. They reset within 2 milliseconds from the time the coil is deenergized. The RC function uses a reed relay with contact ratings stated under RATINGS.

##### F. VI - POSITIVE SEQUENCE VOLTAGE DETECTOR CIRCUIT

Three electrically separate contacts are provided, two normally open and one normally closed. These contacts operate within 17 milliseconds from the time the associated coil is energized by the logic. They reset within 17 milliseconds from the time the coil is deenergized. The VI function uses a telephone-type relay with contact ratings stated under RATINGS.

##### G. TT - TRANSFER TRIP CIRCUIT

Four electrically separate normally open contacts are provided. These contacts close within 0.5 milliseconds from the time the associated coil is energized by the logic. They open within 0.5 milliseconds from the time the coil is deenergized. The TT function uses a reed relay with contact ratings stated under RATINGS.

H. TXA - TRANSMITTER KEYING AUXILIARY

One normally open contact is provided. This contact closes within 0.5 milliseconds from the time the associated coil is energized by the logic. It opens within 0.5 milliseconds from the time the coils is de-energized. The TXA function uses a reed relay with contact ratings as stated under RATINGS. The transistor switch which drives the TXA coil is preceded by a NOT. The relay is normally energized.

I. DLA - DATA LOGGING AMPLIFIER CONTACTS

Three normally open contacts are provided; one each for received carrier, blocking and tripping. These contacts open within 0.5 milliseconds from the time the associated coil is energized by the logic. They open within 0.5 milliseconds from the time the coil is deenergized. The DLA function uses a reed relay with contact ratings as stated under RATINGS.

TARGETS

Two electromechanical target coils are included; one in series with each output contact. These targets operate on one (1) ampere of trip current. The trip circuit resistance in the relay is 0.35 ohm.

Six target lamps are included in the SLAT54G. These are designated as indicated on the internal connection diagram of Fig. 2. An output from TL32 will prevent the target lamps from turning on. A long pickup setting on this timer will permit all functions that operate to light their associated lamps. A short time setting will allow only those functions that operate initially to be indicated.

LOGIC CIRCUITS

The functions of the Type SLAT54G relay involve basic logic (AND, OR, and NOT) where the presence or absence of signals, rather than their magnitude, controls the operation. Signals are measured with respect to a reference bus accessible at TP1. In general a signal below one VDC represents an OFF or LOGIC ZERO condition, an ON or LOGIC ONE state is represented by a signal of approximately  $\pm 15$  VDC.

The symbols used on the internal connection diagram (Fig. 2) are explained by the legend shown in Fig. 4.

CALCULATION OF SETTINGS

There are two timer functions in the SLAT54G that require field adjustment.

- 1) The 5-30/40 timer enables the user to control the number of lamps that will light under certain fault conditions. With a short pickup setting (5-10 milliseconds) only lamp(s) associated with those units which first sensed the fault will light. Increased pickup settings will cause the lamps associated with all units that operate to light. The timer setting should not exceed the minimum breaker clearing time in order to avoid targets which may result from breaker unequal pole opening times.
- 2) The P/25-200 timer insures an adequate duration of the transfer trip signal for dependable tripping at the remote terminal. A setting of six cycles is suggested. This allows a total duration of approximately eight cycles, if two-cycle breakers are used. However, if the channel is also used for direct transfer trip protection of shunt reactors and the line is equipped with reclosing the lock-out of the remote terminal should be delayed until the line protection transfer trip has reset. In this case, the reset delay on P/25-200 should be set to coordinate with the timer which delays lock-out of the remote terminal on shunt reactor faults.

CONSTRUCTION

The SLAT54G relay is packaged in an enclosed metal case with hinged front cover and removable top cover. The outline and mounting dimensions of the case and the physical location of the components are shown in Figs. 1 and 3 respectively.

The SLAT54G relay contains printed circuit cards identified by a code number such as: A110, T114, L102 where A designated an auxiliary function, T designated a time-delay function, and L designated a logical function. The printed circuit cards plug in from the front of the unit. The sockets are marked with letter designations or "addresses" (D,E,F, etc.) which appear on the guide strips in front of each socket, on the component location drawing, on the unit internal connection diagram, and on the printed circuit card. The test points (TP1, TP2, etc.) shown on the internal connection diagram are connected to instrument jacks on a test card in position T or AT with TP1 at the top of the AT card. TP1 and TP11 are tied to reference; TP10 and TP20 are tied to +15 VDC through a 1.5K resistor. This resistor limits the current when TP10 or TP20 is used to supply a logic signal to a card.

The link shown on the internal connection diagram is used to select certain logic options as explained in the logic description. The link is located on the A109 printed circuit card.

This relay receives its inputs from the associated Type SLA relay. These units are interconnected by ten-conductor shielded cables. The sockets for these cables are located on the rear panel of the unit. The output functions are connected to 12-point terminal strips, which are also located on the rear of the unit.

A window is provided in the hinged cover of the relay to allow target lamps and the mechanical targets to be seen. Push buttons are also provided to reset the targets and lamps without opening the cover.

#### RECEIVING, HANDLING AND STORAGE

These relays will normally be supplied as a part of a static relay equipment, mounted in a rack or cabinet with other static relays and test equipment. Immediately upon receipt, the static relay equipment should be unpacked and examined for any damage sustained in transit. If injury or damage resulting from rough handling is evident, file a damage claim at once with the transportation company and promptly notify the nearest General Electric Sales Office.

Reasonable care should be exercised in unpacking the equipment. If the equipment is not to be installed immediately, it should be stored indoors in a location that is free from moisture, dust, metallic chips, and severe atmospheric contaminants.

Just prior to final installation the shipping support bolt should be removed from each side of all relay units, to facilitate possible future unit removal for maintenance. These shipping support bolts are approximately eight inches back from the relay front panel. Static relay equipment, when supplied in swing rack cabinets, should be securely anchored to the floor or to the shipping pallet to prevent the equipment from tipping over when the swing rack is opened.

#### TEST INSTRUCTIONS

If the SLAT54G relay that is to be tested is installed in an equipment which has already been connected to the power system, disconnect the outputs to the system.

#### CAUTION

THE LOGIC SYSTEM SIDE OF THE DC POWER SUPPLY USED WITH MOD III STATIC RELAY EQUIPMENT IS ISOLATED FROM GROUND. IT IS A DESIGN CHARACTERISTIC OF MOST ELECTRONIC INSTRUMENTS THAT ONE OF THE SIGNAL INPUT TERMINALS IS CONNECTED TO THE INSTRUMENT CHASSIS. IF THE INSTRUMENT USED TO TEST THE RELAY EQUIPMENT IS ISOLATED FROM GROUND, ITS CHASSIS MAY HAVE AN ELECTRICAL POTENTIAL WITH RESPECT TO GROUND. THE USE OF A TEST INSTRUMENT WITH A GROUNDED CHASSIS WILL NOT AFFECT THE TESTING OF THE EQUIPMENT. A SECOND GROUND CONNECTION TO THE EQUIPMENT, SUCH AS A TEST LEAD INADVERTENTLY DROPPING AGAINST THE RELAY CASE, MAY CAUSE DAMAGE TO THE LOGIC CIRCUITRY. NO EXTERNAL TEST EQUIPMENT SHOULD BE LEFT CONNECTED TO THE STATIC RELAYS WHEN THEY ARE IN PROTECTIVE SERVICE, SINCE TEST EQUIPMENT GROUNDING REDUCES THE EFFECTIVENESS OF THE ISOLATION PROVIDED.

#### A. GENERAL

The SLAT54G relay is supplied from the factory either mounted in a static relay equipment or as a separate unit associated with measuring relays, a Type SSA power supply, and some form of channel equipment. All relay units for a given terminal of static relaying equipment are tested together at the factory, and each unit will have the same summary number stamped on its nameplate.

Timers should be set for the operating on reset times indicated on the associated overall logic diagram. Where a time range is indicated on the overall logic diagram, the timer should be set for the value recommended for that function in the descriptive write-up accompanying the overall logic diagram. Where a setting depends upon conditions encountered on a specific application, this is so stated and the factors influencing the choice of setting are described. The procedure for checking and setting the timers is described in a later section.

#### B. OPERATIONAL CHECKS

Operation of the SLAT54G unit can be checked by observing the signals at the twenty test points (TP1 to TP20) in the relay by observing the operation of the associated channel equipment, or by observing the output functions. The test points are located on two test cards in positions T and AT, and are numbered 1 to 20 from top to bottom. TP1 is the reference bus for the logic circuit, TP10 is at +15 VDC. The remaining points are located at various strategic points throughout the logic as shown on the internal connection diagram (Fig. 2). Test point voltages can be monitored with a portable high impedance voltmeter, the voltmeter on the test panel of the associated equipment, or an oscilloscope.

C. TEST CARD ADAPTER

The test card adapter provides a convenient means of gaining access to any pin of a particular card. Detailed information on the use of the test adapter card is included in the card instruction book GEK-34158.

D. TIMER ADJUSTMENTS AND TESTS

When the time-delay cards are to be adjusted or checked, an oscilloscope that can display two traces simultaneously and that has a calibrated horizontal sweep should be used.

In order to test the timer cards it is necessary to remove the card which supplied the input to the timer (see Table I) and to place the timer card in a card adapter. The card adapter allows access to the input and output of the timer if they are not brought out on test points. The timer test circuit is shown on Fig. 5. Opening the normally closed contact causes the output to step up to +15 VDC after the pickup delay of the timer. To increase the pickup time, turn the upper potentiometer on the timer card clockwise; to decrease the time turn it counterclockwise. Closing the contact causes the timer output to drop out after the reset time-delay setting of the card. If the timer card is provided with a variable reset delay, it can be adjusted by the lower potentiometer on the timer card (clockwise increases reset time).

TABLE I

TIME UNDER TEST	POSITION	REMOVE E CARD IN POSITION
TL32	AP	AN
TL41	R	AN
TL42	N	NONE*

\*Turn d-c supply switch on and off

E. TRIP CIRCUIT TESTS

The trip circuits and series mechanical targets may be checked by connecting an auxiliary lock-out relay, such as the Type HEA relay, in series with the trip circuit. A typical circuit is shown in Fig. 6. The HEA relay should have the same d-c rating as the trip circuit of the relay. If an auxiliary lock-out relay is not available, it can be replaced by a resistive load which limits the trip circuit current to three amperes. In most equipments, the trip circuit can be energized by operating a test push button.

TABLE II

CONTACT RATING - TELEPHONE-TYPE RELAYS

VOLTS	INTERRUPTION CAPACITY INDUCTIVE* (AMPS)
48 DC	1.00
125 DC	0.50
250 DC	0.25
115 - 60 CYC	0.75
230 - 60 CYC	0.50
CONTINUOUS CURRENT RATING - 3.0	

\*The non-inductive interrupting ratings for repetitive protective duty are approximately 2-1/2 times the ratings shown above.

Prior to final installation, a check of the overall trip circuit should be made with the trip contacts connected to trip the circuit breakers.

F. OVERALL EQUIPMENT TESTS

After the SLAT54G relay and the associated static relay units have been individually calibrated and tested for the desired settings, a series of overall operating circuit checks is advisable.

The elementary overall logic, and logic description for the specific job will be useful for determining the overall operation of the scheme.

Overall equipment tests can be performed by applying alternating current and voltages to the measuring units as specified in the instruction book for the measuring units and checking that proper outputs are obtained when the measuring units operate.

## MAINTENANCE

### A. PERIODIC TESTS

It should be sufficient to check the outputs produced at test points in the SLAT54G where periodic calibration tests are made on the associated measuring units, for example, the phase and ground relays in a line-relaying scheme. No separate periodic tests on the relay itself should be required.

### B. TROUBLESHOOTING

In any troubleshooting of equipment, first establish which unit is functioning incorrectly. The overall logic diagram supplied with the equipment shows the combined logic of the complete equipment and the various test points in each unit. By signal tracing, using the overall logic diagram and the various test points, it should be possible to quickly isolate the trouble.

A test adapter card is supplied with each static relay equipment to supplement the prewired test points on the test cards. Use of the adapter card is described in the card instruction book GEK-34158.

A dual-trace oscilloscope is a valuable aid to detailed troubleshooting, since it can be used to determine phase shift, operate and reset times as well as input and output levels. A portable dual-trace oscilloscope with a calibrated sweep and trigger facility is recommended.

### C. SPARE PARTS

To minimize possible outage time, it is recommended that a complete maintenance program should include the stocking of at least one spare card of each type. It is possible to replace damaged or defective components on the printed circuit cards, but great care should be taken in soldering so as not to damage or bridge-over the printed circuit busses, or overheat the semi-conductor components. The repaired area should be recovered with a suitable high-dielectric plastic coating to prevent possible breakdowns across the printed busses due to moisture and dust. The wiring diagrams for the cards in the SLAT54G relay are included in the card book GEK-34158.



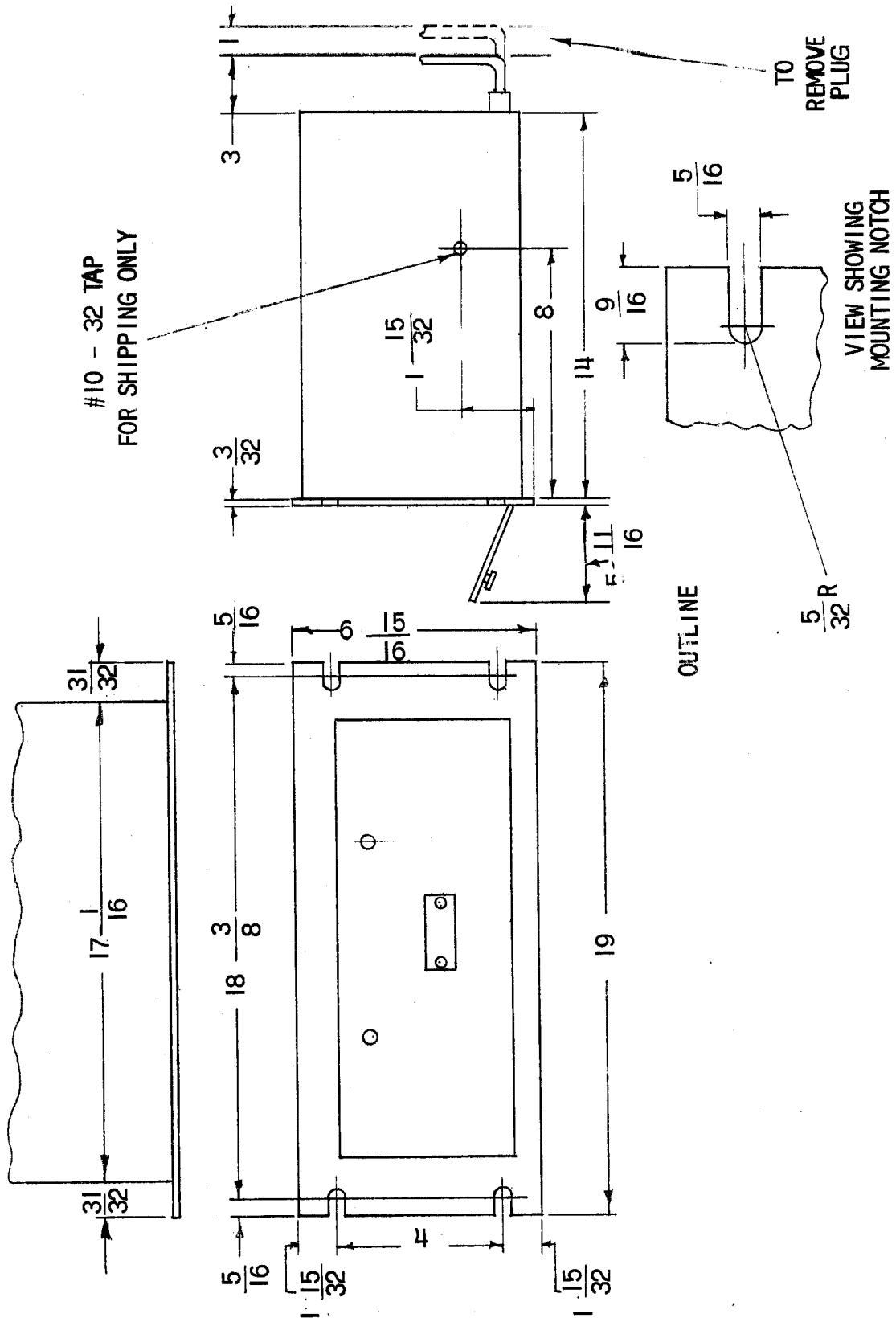

FIG. 1 (0227A2037-0) Outline and Mounting Dimensions for the Type SLAT54G Relay

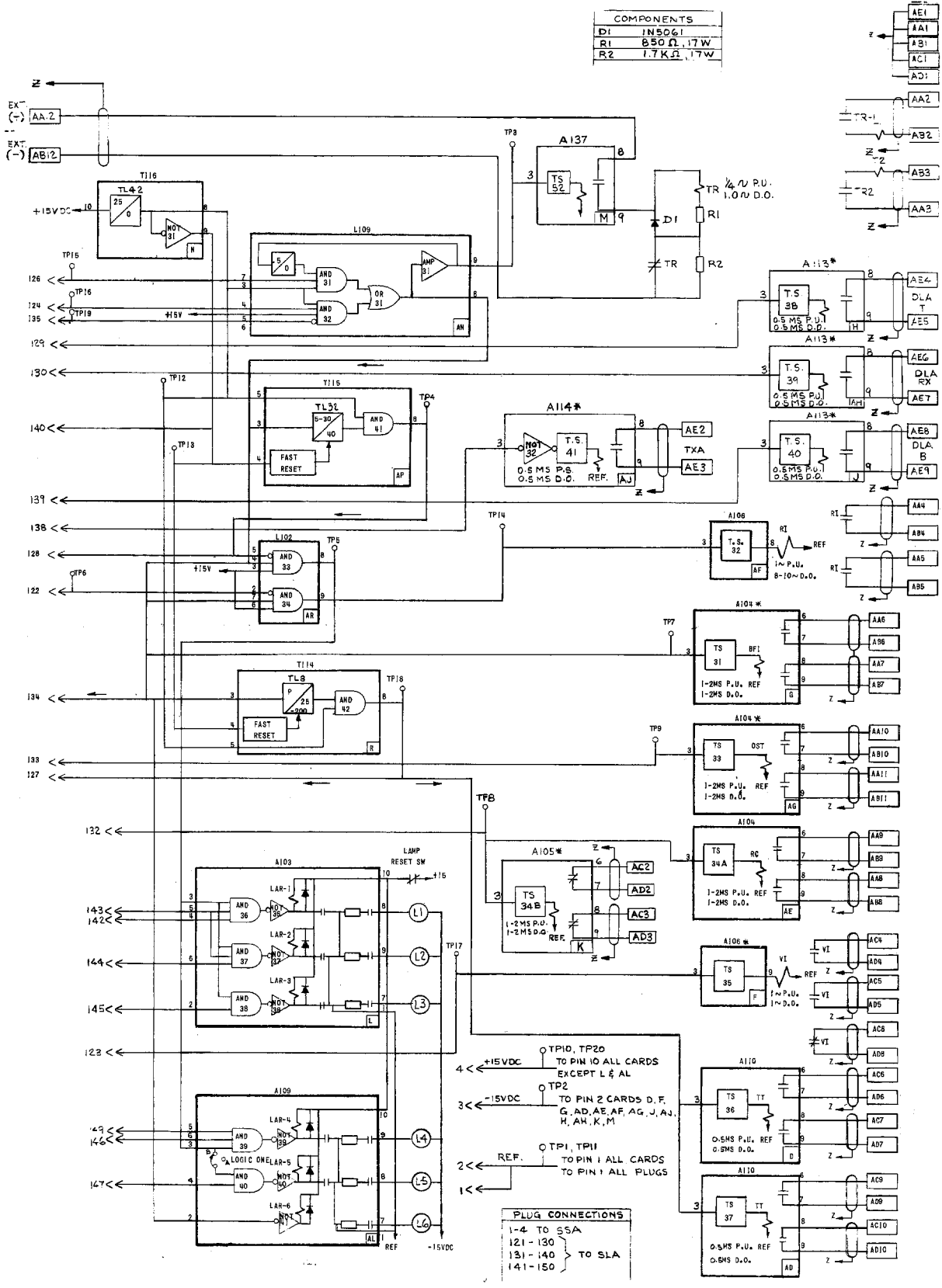
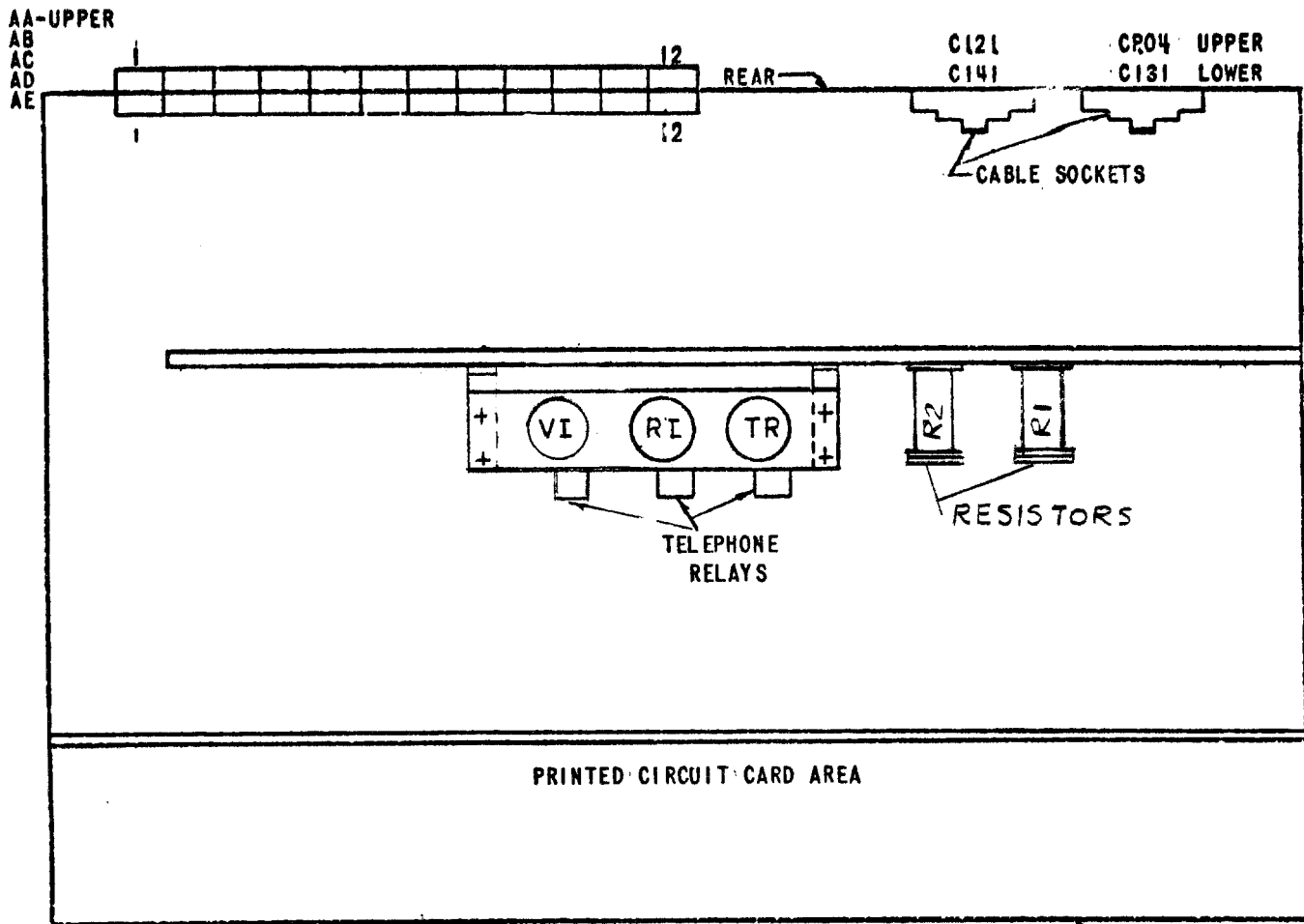
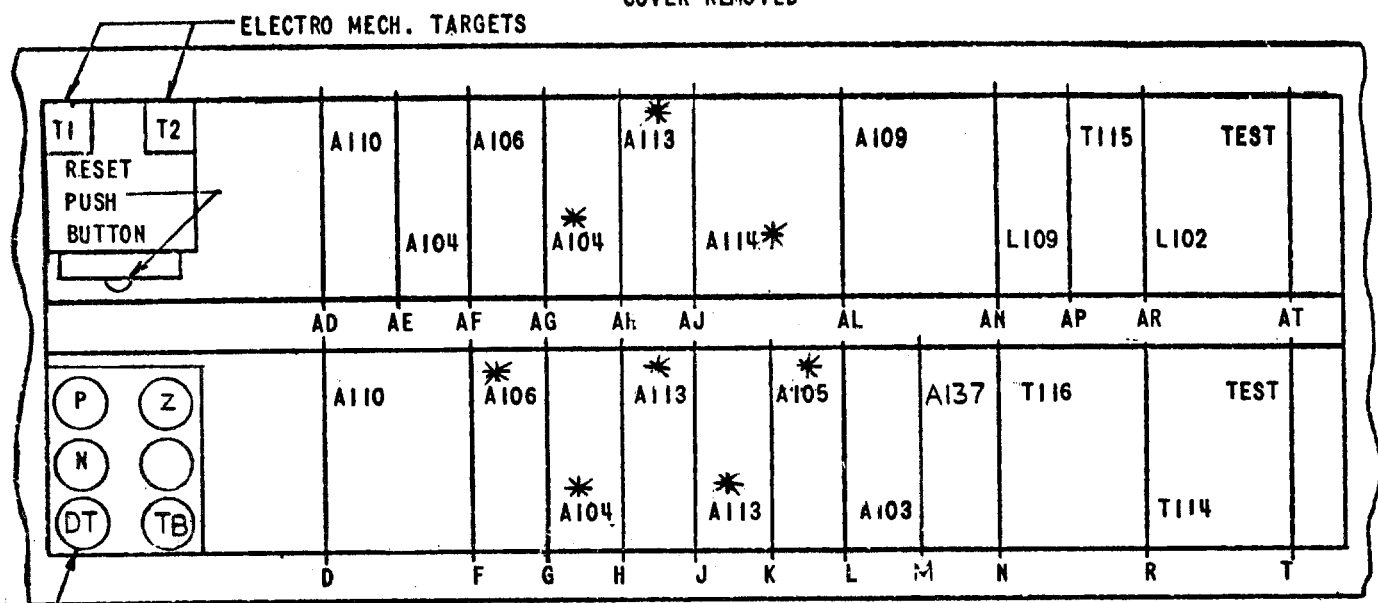

FIG. 2 (171C7887-1) Internal Connections for the Type SLAT54G Relay



TOP VIEW  
COVER REMOVED



FRONT VIEW  
COVER REMOVED

\* OPTIONAL CARDS - SEE INTERNAL CONNECTION DIAGRAM

FIG. 3 (257A8792-0) Component and Card Locations for the Type SLAT54G Relay

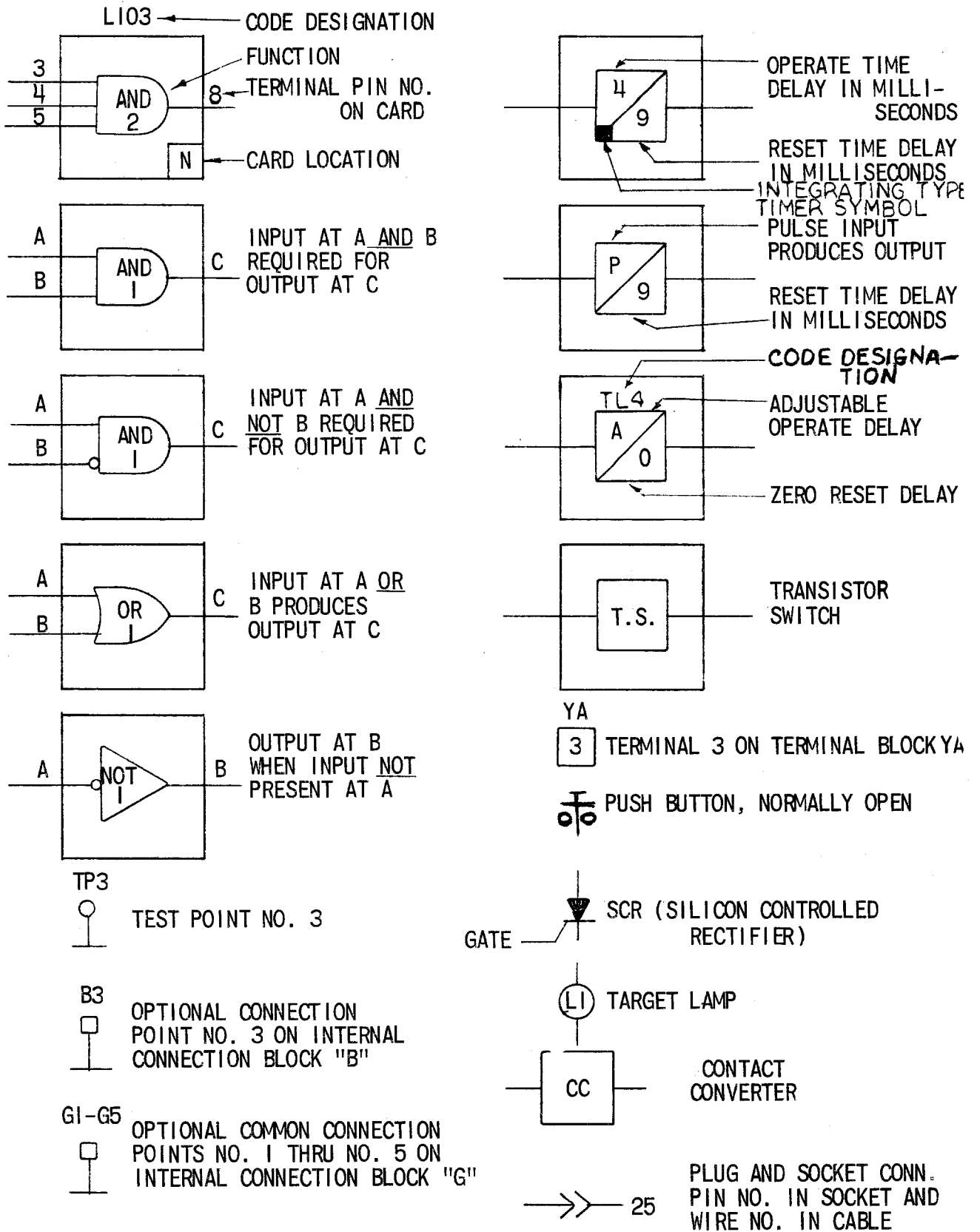
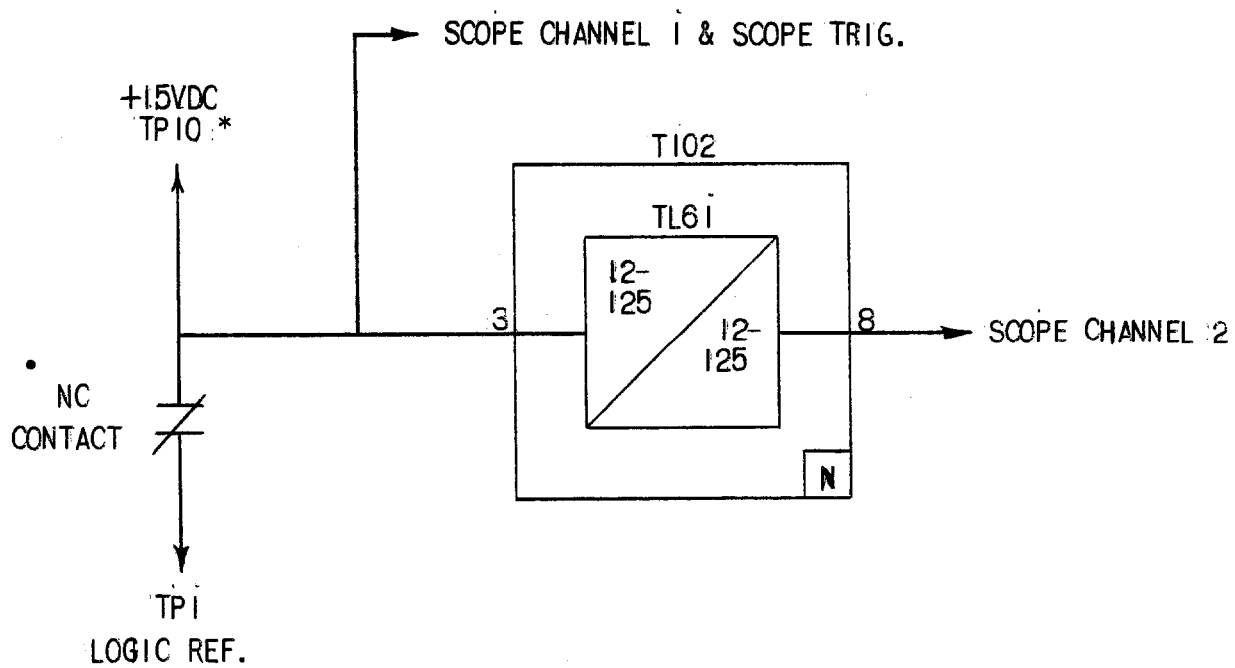

FIG. 4 (0227A2047-1) Internal Connection Diagram Legend



\* THE 15VDC SIGNAL AT PIN 10 HAS A CURRENT LIMITING RESISTOR MOUNTED ON THE TEST CARD.

FIG. 5 (0246A7987-0) Logic Timer Test Circuit

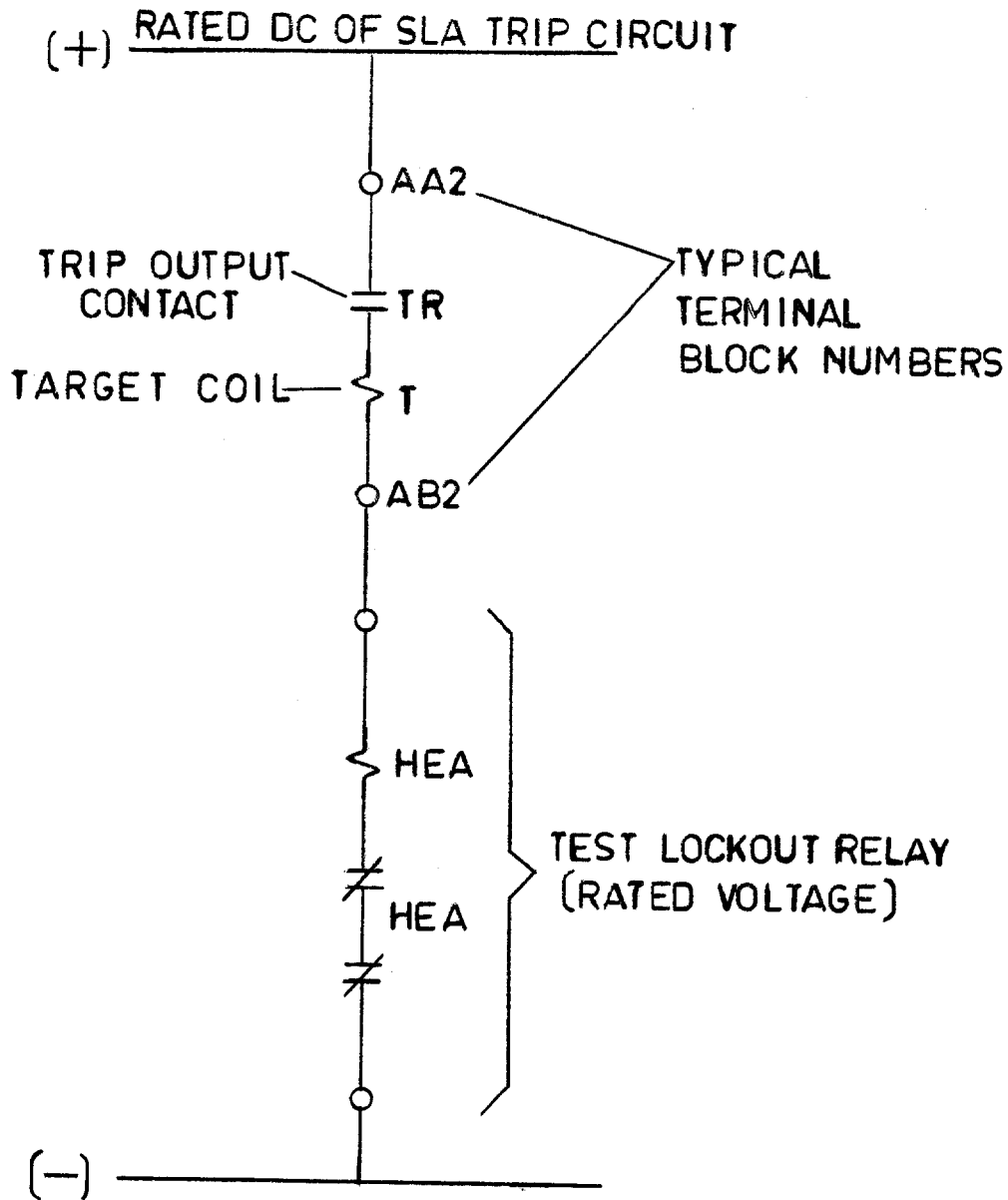

FIG. 6 (0275A1318-0) Typical Trip Circuit Test Connections for Relays with Trip Contacts