



Instructions

GEK-49785B
Supersedes GEK-49785A

STATIC OUTPUT TRIPPING UNIT

TYPE SLAT51J

These instructions do not purport to cover all details or variations in equipment nor to provide for every possible contingency to be met in connection with installation, operation or maintenance. Should further information be desired or should particular problems arise which are not covered sufficiently for the purchaser's purposes, the matter should be referred to the General Electric Company.

To the extent required the products described herein meet applicable ANSI, IEEE and NEMA standards; but no such assurance is given with respect to local codes and ordinances because they vary greatly.

CONTENTS

	<u>PAGE</u>
DESCRIPTION	3
APPLICATION	3
SETTINGS	3
RATINGS	3
BURDENS	4
FUNCTIONS	4
SCR TRIP CIRCUIT	4
RI RECLOSE INITIATE CIRCUIT	4
RR32, RR33 (A104)	4
RR32	5
V1 POSITIVE SEQUENCE VOLTAGE DETECTOR CIRCUIT	5
AUXILIARY REED RELAY OUTPUTS	5
CONTACT CONVERTERS	5
TL31 DC SUPERVISION	5
TARGETS	5
LOGIC CIRCUITS	6
CONSTRUCTION	6
RECEIVING, HANDLING AND STORAGE	6
TEST INSTRUCTIONS	7
CAUTION	7
GENERAL	7
OPERATIONAL CHECKS	8
TEST CARD ADAPTER	8
TIMER ADJUSTMENTS AND TESTS	8
TRIP CIRCUIT TESTS	8
OVERALL EQUIPMENT TESTS	9
MAINTENANCE	9
PERIODIC TESTS	9
TROUBLESHOOTING	9
SPARE PARTS	9

STATIC OUTPUT AND TRIPPING UNIT

TYPE SLAT51J

DESCRIPTION

The Type SLAT51J is a tripping and output unit providing two SCR tripping outputs for tripping either a single pole or three poles, depending on the type of scheme in which it is used.

The target circuitry provides six target lamps in the unit. Provision is made for seven double contact (isolated) outputs, two single contact outputs, and one three-contact output. When supplied, these contacts are normally used for reclosing initiation, breaker failure initiation, keying direct transfer trip channels, out-of-step trip keying, positive sequence voltage indication, and various data logging indications.

APPLICATION

When the SLAT51J is used with the Type SLA auxiliary logic unit, the output contacts can often be connected to various points in the logic circuit, thereby providing the opportunity for bringing out the status of a point in the logic for special control or indication purposes.

SETTINGS

When TT contacts are used for keying a direct transfer trip channel, the setting of the TL32 timer should be sufficiently long to override the high noise levels generated when tripping the local breakers, but sufficiently short so as not to interfere with high speed reclosing at the remote terminal. A typical setting would be 100 to 125 milliseconds.

RATINGS

The Type SLAT51J relay is designed for use in an environment where the ambient temperature around the relay case is between minus 20°C and plus 65°C.

The Type SLAT51J relay requires a plus or minus 15 volt DC power source which can be obtained from a Type SSA50/51 or other appropriate power supply.

The SCR tripping circuits are rated for 48/125 or 250 volt DC. Each has a 1.0 ampere series target. The tripping circuits are designed to carry 30 amperes for one second.

The contacts of the telephone-type relays will make and carry three amperes continuously and will interrupt up to 180 volt-amperes resistive (60 volt-amperes inductive). The contacts will make and carry 30 amperes for one second.

The contacts of the A104 and A105 reed relay cards will make and carry three amperes for tripping duty and are continuously rated for three amperes. The contacts will interrupt up to 100 volt-amperes resistive (35 volt-amperes inductive).

The contacts of the reed relays that are used for RR31, RR38, RR39, RR40 and RR41 relays are rated for ten volt-amperes. They will carry 0.5 ampere continuously.

Each contact converter in this relay has a link for selecting the proper voltage for the coil circuit of the contact converter. The available voltage taps are for 48, 125 or 250 volts DC.

Refer to the unit nameplate for the trip circuit rating of a particular relay.

BURDENS

The SLAT51J relay presents a maximum burden to the power supply of:

100 milliamperes from the plus 15 volt DC supply
400 milliamperes from the minus 15 volt DC supply

FUNCTIONS

SCR TRIP CIRCUIT

Electrically separate, isolated SCR trip circuits are provided to trip two breakers. Each circuit is capable of carrying 30 amperes for one second.

The internal connections for the SCR trip and isolator subassemblies are shown in Figure 1. The isolator card, by means of a DC-to-DC converter, provides a signal path but maintains metallic isolation. This feature makes it possible to isolate the relay power supply from the trip circuit power supply.

RI RECLOSE INITIATE CIRCUIT

Two electrically separate normally open contacts are provided. These contacts close within 17 milliseconds from the time the associated coil is energized by the logic. The contacts open within 17 milliseconds from the time the coil is de-energized. The RI functions use a telephone-type relay with contact ratings stated under **RATINGS**.

RR32, RR33 (A104)

Two electrically separate normally open contacts are provided. These contacts close within two milliseconds from the time the coil is energized. The functions use a reed relay with contact ratings stated under **RATINGS**.

RR32

Two electrically separate normally closed contacts are provided. These contacts operate within two milliseconds from the time the associated coil is energized by the logic. They reset within two milliseconds from the time the coil is de-energized. The function uses a reed relay with contact ratings stated under **RATINGS**.

V1 - POSITIVE SEQUENCE VOLTAGE DETECTOR CIRCUIT

Three electrically separate contacts are provided, two normally open and one normally closed. These contacts operate within 17 milliseconds from the time the associated coil is energized by the logic. They reset within 17 milliseconds from the time the coil is de-energized. The V1 function uses a telephone-type relay with contact ratings stated under **RATINGS**.

AUXILIARY REED RELAY OUTPUTS

The usage of these reed relay outputs is determined by the particular scheme in which the SLAT51J is employed. RR31, RR38 and RR41 each have two electrically separate contacts. RR39 and RR40 each have one contact. The ratings of the contacts of the reed relays are stated under **RATINGS**.

CONTACT CONVERTERS

The purpose of the contact converter (CC31) included in the Type SLAT51J relay is to convert a contact operation into a signal that is compatible with the logic circuitry of the relay.

When the external contact associated with CC31 operates, the output relays are blocked from operation.

TL31 DC SUPERVISION

TL31 is a non-adjustable timer (75/0) that provides DC supervision of relay logic circuits. When DC is removed, TL31 will prevent any trip outputs until 75 milliseconds after DC has been re-established. NOT31 provides a fast reset signal to all timers with reset times longer than 25 milliseconds that could produce a spurious trip output upon removal of DC.

TARGETS

Two electromechanical target coils are included, one in series with each SCR. These targets operate on one ampere of trip current when the associated SCR passes current. The trip circuit resistance in the relay is 0.40 ohm.

Six lamps are included in the SLAT51J for target indication. These lamps are all supervised by the trip bus and can be used to indicate what functions in the relaying scheme operated to cause the trip. The inputs which drive the target contacts will be shown on the associated overall logic.

LOGIC CIRCUITS

The functions of the Type SLAT51J relay involve basic logic (AND, OR, and NOT) where the presence or absence of signals, rather than their magnitude, controls the operation. Signals are measured with respect to a reference bus accessible at TP1. In general, a signal below one volt DC represents an OFF or LOGIC ZERO condition; an ON or LOGIC ONE state is represented by a signal of approximately plus or minus 15 volts DC.

The symbols used on the internal connection diagram (Figure 2) are explained by the legend shown in Figure 3.

CONSTRUCTION

The SLAT51J relay is packaged in an enclosed metal case with hinged front cover and removable top cover. The outline and mounting dimensions of the case and the physical location of the components are shown in Figure 4 and 5, respectively.

The SLAT51J relay contains printed circuit cards identified by a code number, such as A110, T114, L102; where A designates auxiliary function, T designates a time-delay function, and L designates a logic function. The printed circuit cards plug in from the front of the unit. The sockets are marked with letter designations or "addresses" (D, E, F, etc.) which appear on the guide strips in front of each socket, on the component location drawing, on the unit internal connection diagram, and on the printed circuit card. The test points (TP1, TP2, etc.) shown on the internal connection diagram are connected to instrument jacks on a test card in position T or AT with TP1 at the top of the AT card. TP1 is tied to reference; TP10 is tied to plus 15 volts DC through a 1.5K resistor. This resistor limits the current when TP10 is used to supply a logic signal to a card.

The SLAT51J relay receives its inputs from the associated Type SLA relay. These units are interconnected by ten conductor shielded cables. The sockets for these cables are located on the rear panel of the unit. The SLAT51J output functions are connected to 12-point terminal strips, which are also located on the rear of the unit.

A window is provided in the hinger cover of the relay to allow the mechanical targets to be seen. A pushbutton is also provided to reset the electromechanical targets and the target lamps without opening the cover.

RECEIVING, HANDLING AND STORAGE

These relays will normally be supplied as part of a static relay equipment, mounted in a rack or cabinet with other static relays and test equipment. Immediately upon receipt of a static relay equipment, it should be unpacked and examined for any damage sustained in transit. If injury or damage resulting from rough handling is evident, file a damage claim at once with the transportation company and promptly notify the nearest General Electric Sales Office.

Reasonable care should be exercised in unpacking the equipment. If the equipment is not to be installed immediately, it should be stored indoors in a location that is free from moisture, dust, metallic chips, and severe atmospheric contaminants.

Just prior to final installation the shipping support bolt should be removed from each side of all relay units, to facilitate possible future unit removal for maintenance. These shipping support bolts are approximately eight inches back from the relay front panel. STATIC RELAY EQUIPMENT, WHEN SUPPLIED IN SWING RACK CABINETS, SHOULD BE SECURELY ANCHORED TO THE FLOOR OR TO THE SHIPPING PALLET TO PREVENT THE EQUIPMENT FROM TIPPING OVER WHEN THE SWING RACK IS OPENED.

TEST INSTRUCTIONS

If the SLAT51J relay that is to be tested is installed in an equipment which has already been connected to the power system, disconnect the outputs from the system before testing.

CAUTION

THE LOGIC SYSTEM SIDE OF THE DC POWER SUPPLY USED WITH MOD III STATIC RELAY EQUIPMENT IS ISOLATED FROM GROUND. IT IS A DESIGN CHARACTERISTIC OF MOST ELECTRONIC INSTRUMENTS THAT ONE OF THE SIGNAL INPUT TERMINALS IS CONNECTED TO THE INSTRUMENT CHASSIS. IF THE INSTRUMENT USED TO TEST THE RELAY EQUIPMENT IS ISOLATED FROM GROUND, ITS CHASSIS MAY HAVE AN ELECTRICAL POTENTIAL WITH RESPECT TO GROUND. THE USE OF A TEST INSTRUMENT WITH A GROUNDED CHASSIS WILL NOT AFFECT THE TESTING OF THE EQUIPMENT. HOWEVER, A SECOND GROUND CONNECTION TO THE EQUIPMENT, SUCH AS A TEST LEAD INADVERTENTLY DROPPING AGAINST THE RELAY CASE, MAY CAUSE DAMAGE TO THE LOGIC CIRCUITRY. NO EXTERNAL TEST EQUIPMENT SHOULD BE LEFT CONNECTED TO THE STATIC RELAYS WHEN THEY ARE IN PROTECTIVE SERVICE, SINCE TEST EQUIPMENT GROUNDING REDUCES THE EFFECTIVENESS OF THE ISOLATION PROVIDED.

GENERAL

The SLAT51J relay is supplied from the factory either mounted in a static relay equipment or as a separate unit associated with measuring relays, a power supply, and some form of channel equipment. All relay units for a given terminal of static relaying equipment are tested together at the factory, and each unit will have the same summary number stamped on its nameplate.

Timers should be set for the operating and reset times indicated on the associated overall logic diagram. Where a time range is indicated on the overall logic diagram, the timer should be set for the value recommended for that function in the descriptive writeup accompanying the overall logic diagram. Where a setting depends upon conditions encountered on a specific application, this is so stated and the factors influencing the choice of setting are described. The procedure for checking and setting the timers is described in a later section.

OPERATIONAL CHECKS

Operation of the SLAT51J unit can be checked by observing the signals at the twenty test points (TP1 to TP20) in the SLAT51J, by observing the operation of the associated channel equipment, or by observing the output functions. The test points are located on two test cards in positions T and AT and are numbered 1 to 20 from top to bottom. TP1 is the reference bus for the logic circuit; TP10 is at plus 15 volts DC. The remaining points are at various strategic locations throughout the logic as shown on the internal connection diagram (Figure 2). Test point voltages can be monitored with a portable high impedance voltmeter, the voltmeter on the test panel of the associated equipment, or an oscilloscope.

Operation of any logic function may be checked by supplying the correct inputs to the card. This is accomplished by placing the card under test in a card extender, removing the cards which normally supply the input signals, and then connecting the card inputs to either TP10 or TP1. An output should be produced when the proper combination of inputs is supplied to the card.

TEST CARD ADAPTER

The test card adapter provides a convenient means of gaining access to any pin of a particular card. Detailed information on the use of the test adapter card is included in the printed circuit card instruction book, GEK-34158.

TIMER ADJUSTMENTS AND TESTS

When the time-delay cards are to be adjusted or checked, an oscilloscope that can display two traces simultaneously, and that has a calibrated horizontal sweep, should be used.

In order to test the timer cards it is necessary to remove the card which supplied the input to the timer and to place the timer card in a card adapter. The card adapter allows access to the input and output of the timer if they are not brought out on test points. The timer test circuit is shown in Figure 6. Opening the normally closed contact causes the output to step up to plus 15 volts DC after the pickup delay of the timer. To increase the pickup time, turn the upper potentiometer on the timer card clockwise; to decrease the time, turn it counterclockwise. Closing the contact causes the timer output to drop out after the reset time-delay; it can be adjusted by the lower potentiometer on the timer card (clockwise increases reset time).

TRIP CIRCUIT TESTS

The SCR trip circuits and the series mechanical targets may be checked by connecting an auxiliary lock-out relay, such as the Type HEA relay, in series with the SCR circuit. A typical circuit is shown in Figure 7. The HEA relay should have the same DC rating as the SCR trip circuit of the SLAT51J. If an auxiliary lock-out relay is not available, it can be replaced by a resistive load which limits the trip circuit current to three amperes. In most equipments, the SCR can be gated by operating a test push button in the associated units.

Prior to final installation, a check of the overall trip circuits should be made with the SCR outputs connected to trip the circuit breakers.

OVERALL EQUIPMENT TESTS

After the SLAT51J relay and the associated static relay units have been individually calibrated and tested for the desired settings, a series of overall operating circuit checks is advisable.

The elementary, overall logic and logic description for the specific job will be useful for determining the overall operation of the scheme.

Overall equipment tests can be performed by applying alternating current and voltages to the measuring units as specified in the instruction book for the measuring units and checking that proper outputs are obtained when the measuring units operate.

MAINTENANCE

PERIODIC TESTS

It should be sufficient to check the outputs produced at test points in the SLAT51J when periodic calibration tests are made on the associated measuring units, for example, the phase and ground relays in line-relaying scheme. No separate periodic tests on the SLAT51J itself should be required.

TROUBLESHOOTING

In any troubleshooting of equipment, it should first be established which unit is functioning incorrectly. The overall logic diagram supplied with the equipment shows the combined logic of the complete equipment and the various test points in each unit. By signal tracing, using the overall logic diagram and the various test points, it should be possible to quickly isolate the trouble.

A test adapter card is supplied with each static relay equipment to supplement the prewired test points on the test cards. Use of the adapter card is described in the printed circuit card instruction book, GEK-34158.

A dual trace oscilloscope is a valuable aid to detailed troubleshooting, since it can be used to determine phase shift, operate and reset times, as well as input and output levels. A portable dual-trace oscilloscope with a calibrated sweep and trigger facility is recommended.

SPARE PARTS

To minimize possible outage time, it is recommended that a complete maintenance program should include the stocking of a least one spare card of each type. It is possible to replace damaged or defective components on the printed circuit cards, but great care should be taken in soldering so as not to damage or bridge-over the printed circuit buses, or overheat the semiconductor components. The repaired area should be recovered with a suitable high-dielectric plastic coating to prevent possible breakdowns across the printed buses due to moisture and dust. The wiring diagrams for the cards in the SLAT51J relay are included in the printed circuit card instruction book, GEK-34158.

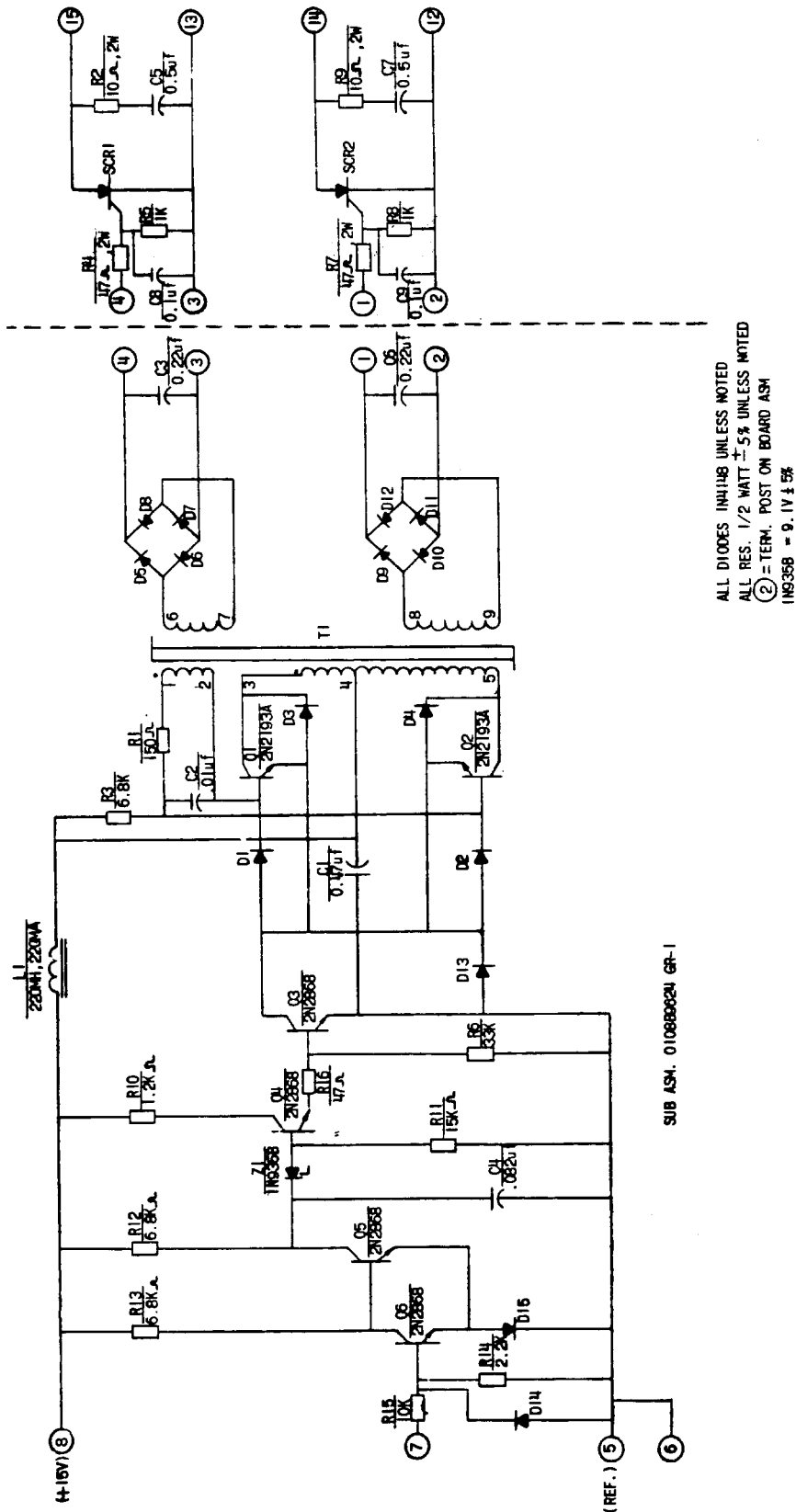

Figure 1 (0108B9610-0) Internal Connections for the SCR Trip and Isolation Subassemblies

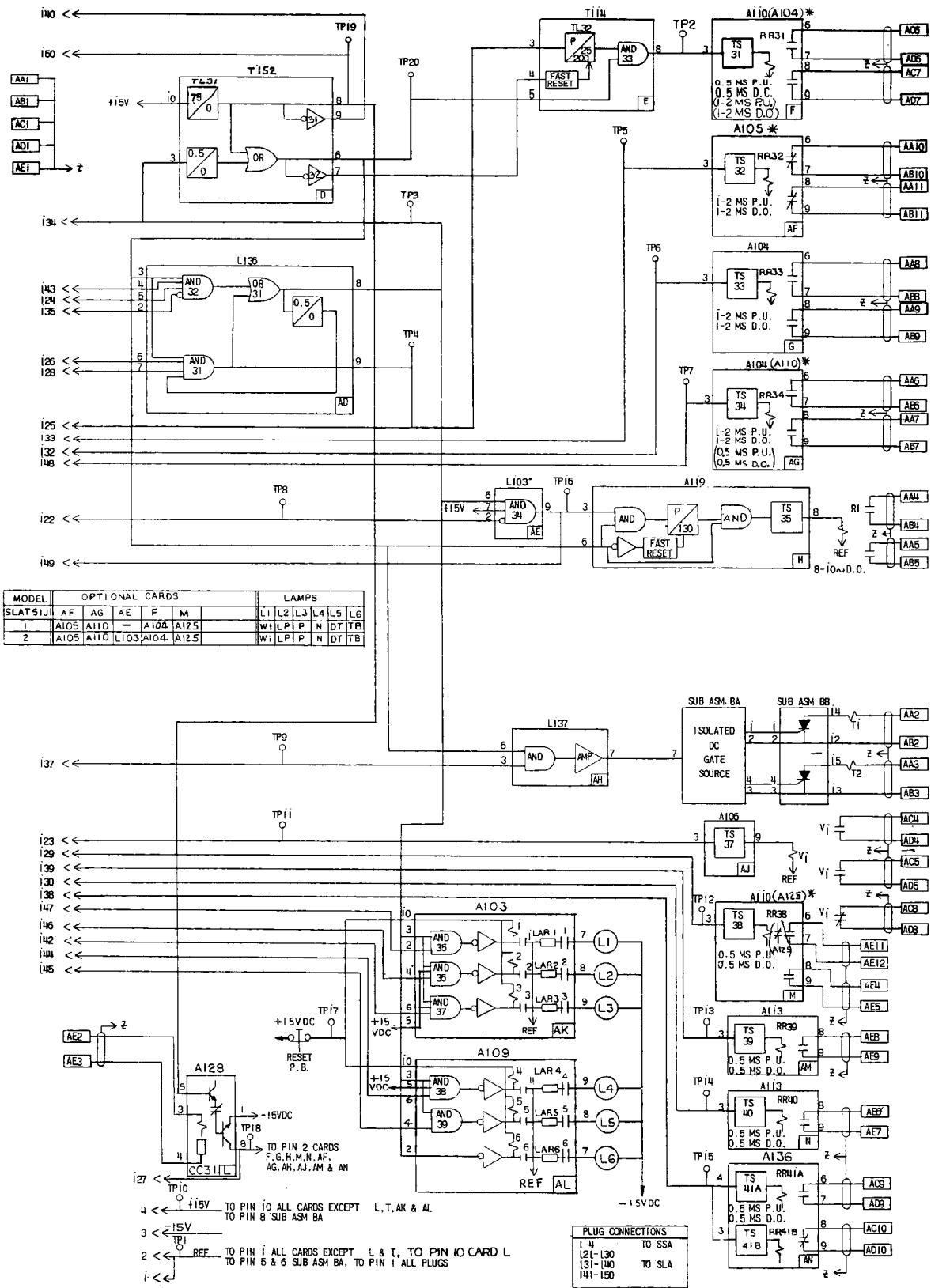

Figure 2A (0171C7886-3) Internal Connections Diagram for the Type SLAT51J (Forms 1 and 2)

*Indicates Revision

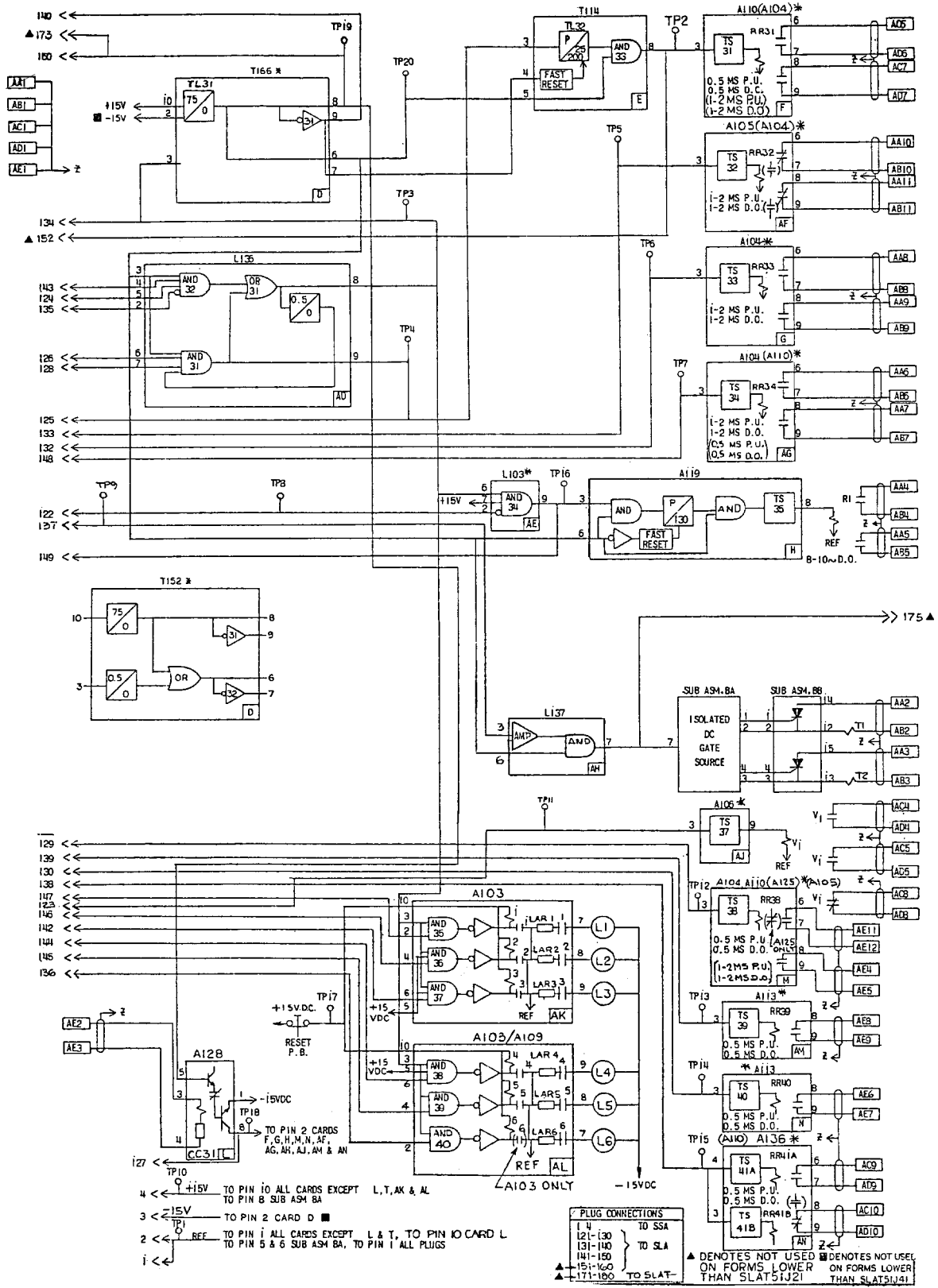

Figure 2B (0172C5115-13) Internal Connections Diagram for the Type SLAT51J (Forms 11 and up)

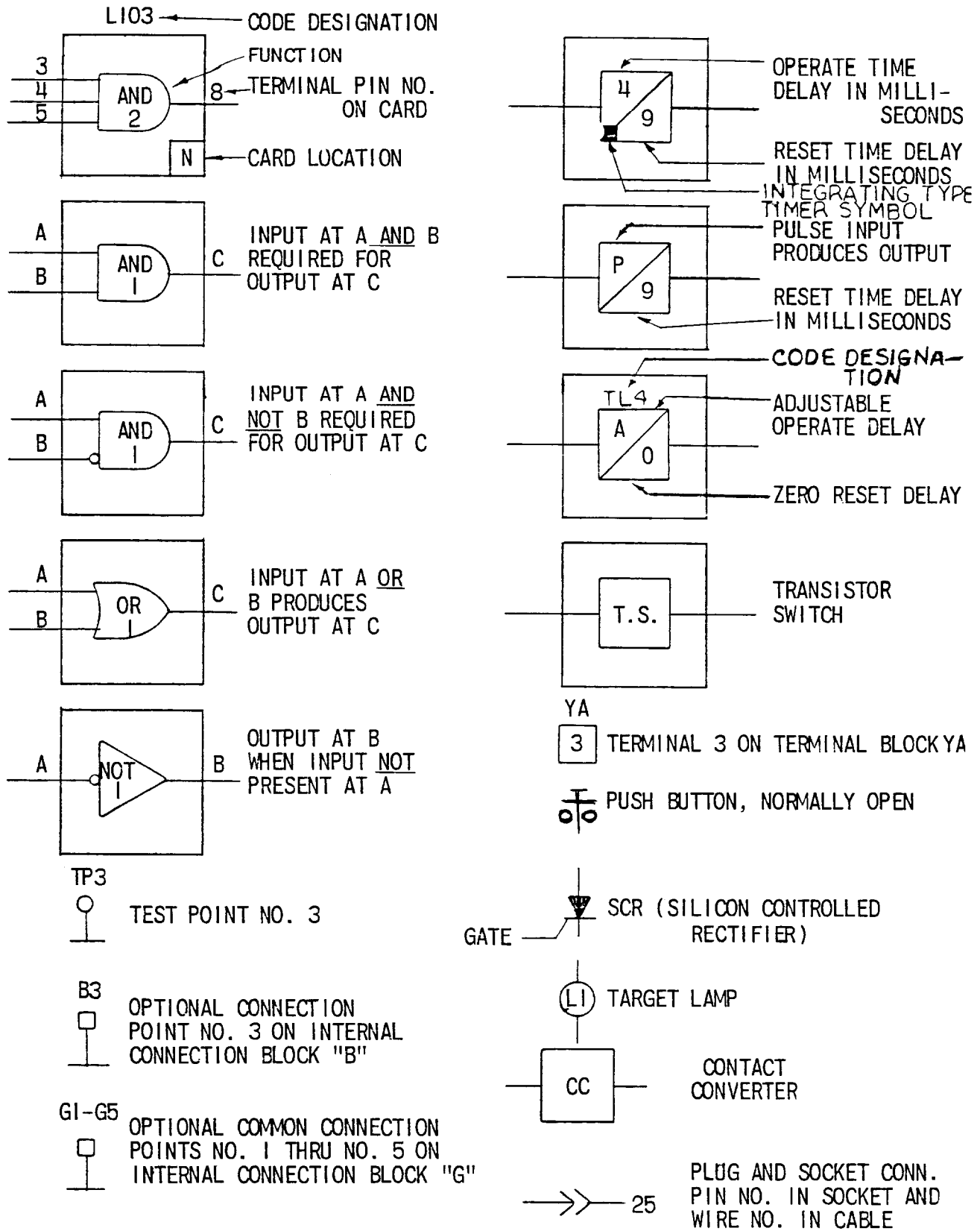

Figure 3 (0227A2047-1) Internal Connection Diagram Legend

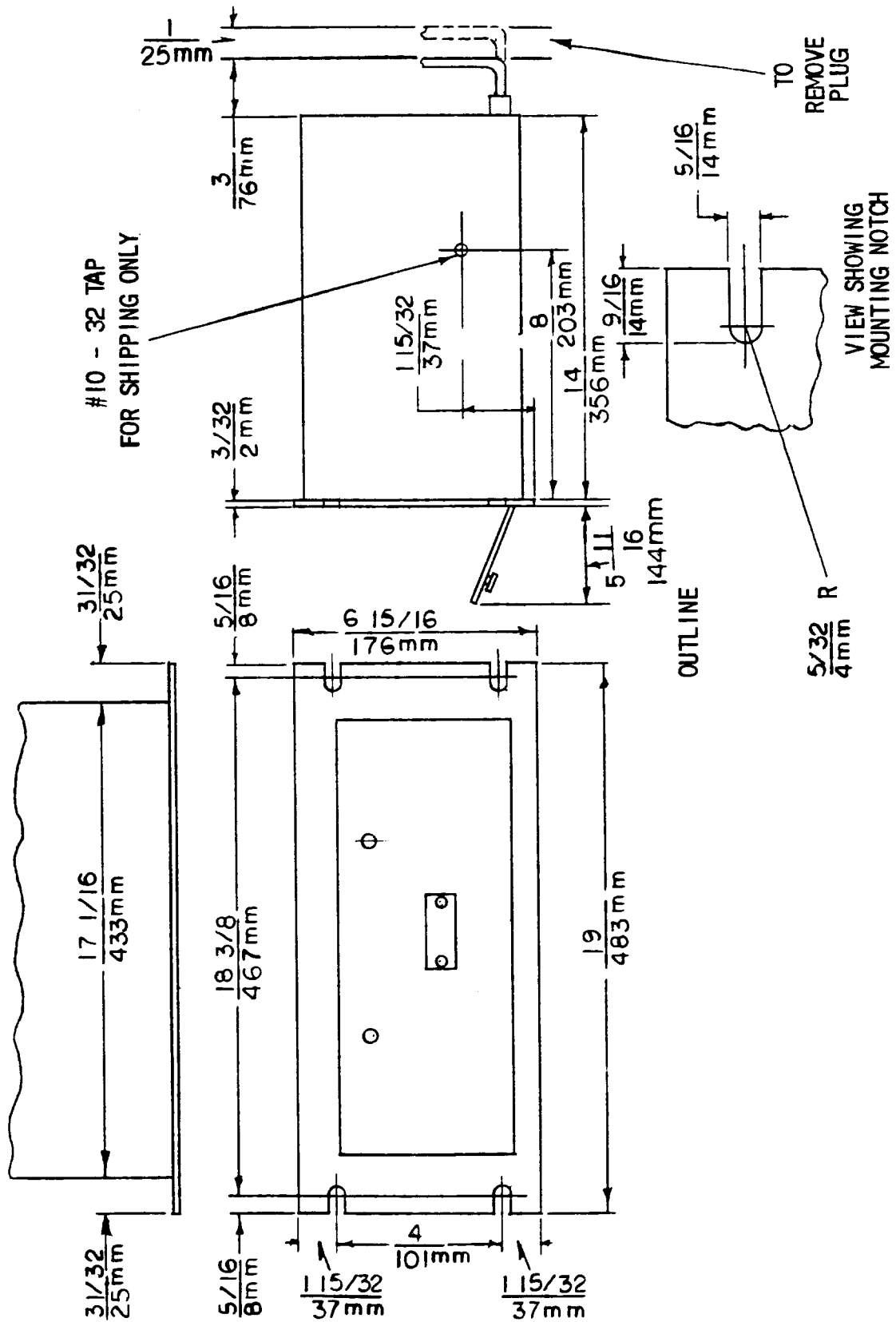
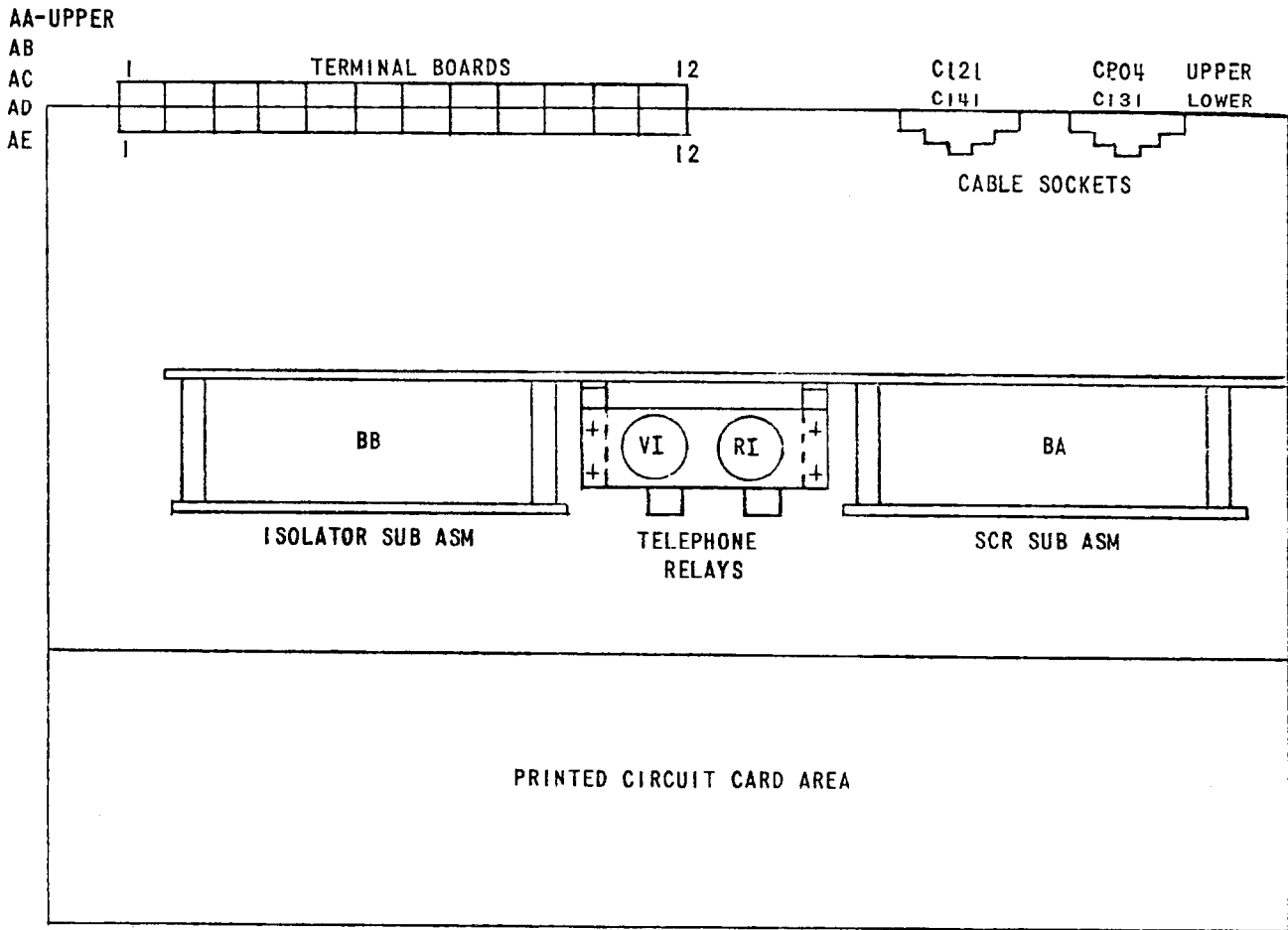

Figure 4 (0227A2037-1) Outline and Mounting Dimensions for the Type SLAT51J Relay

GEK-49785



TOP VIEW

(COVER REMOVED)

FRONT

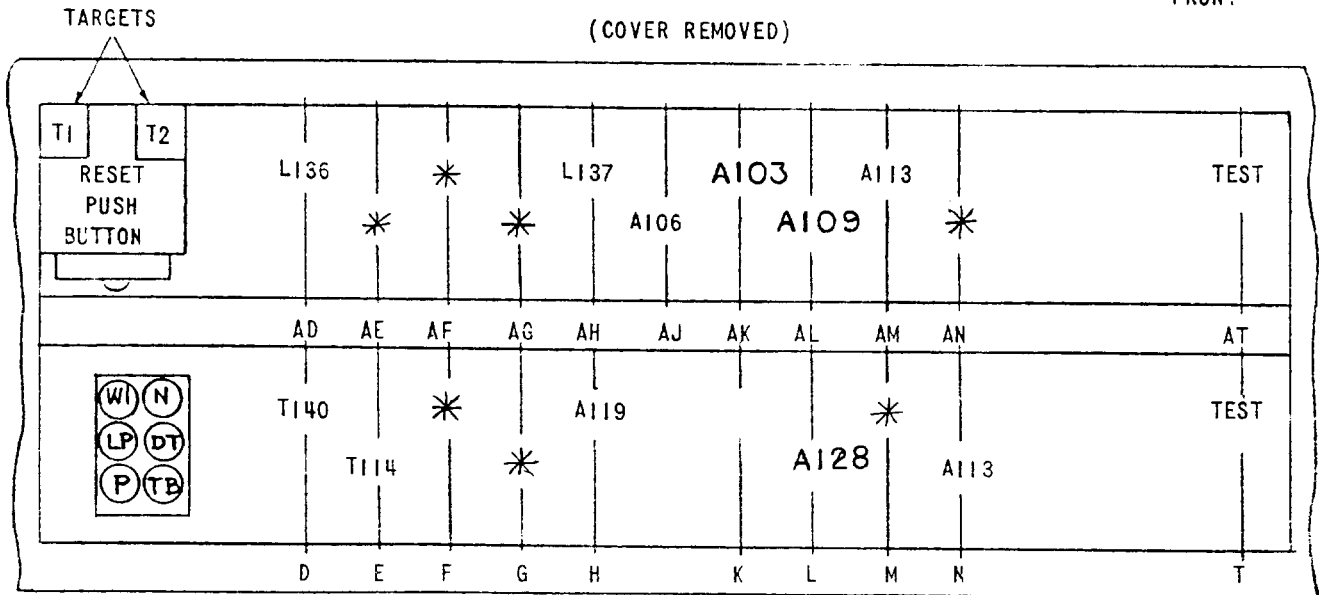

FRONT VIEW

(COVER REMOVED)

* = OPTIONAL CARD, SEE UNIT INTERNAL

Figure 5 (0257A8793-0) Component and Card Locations for the Type SLAT51J Relay

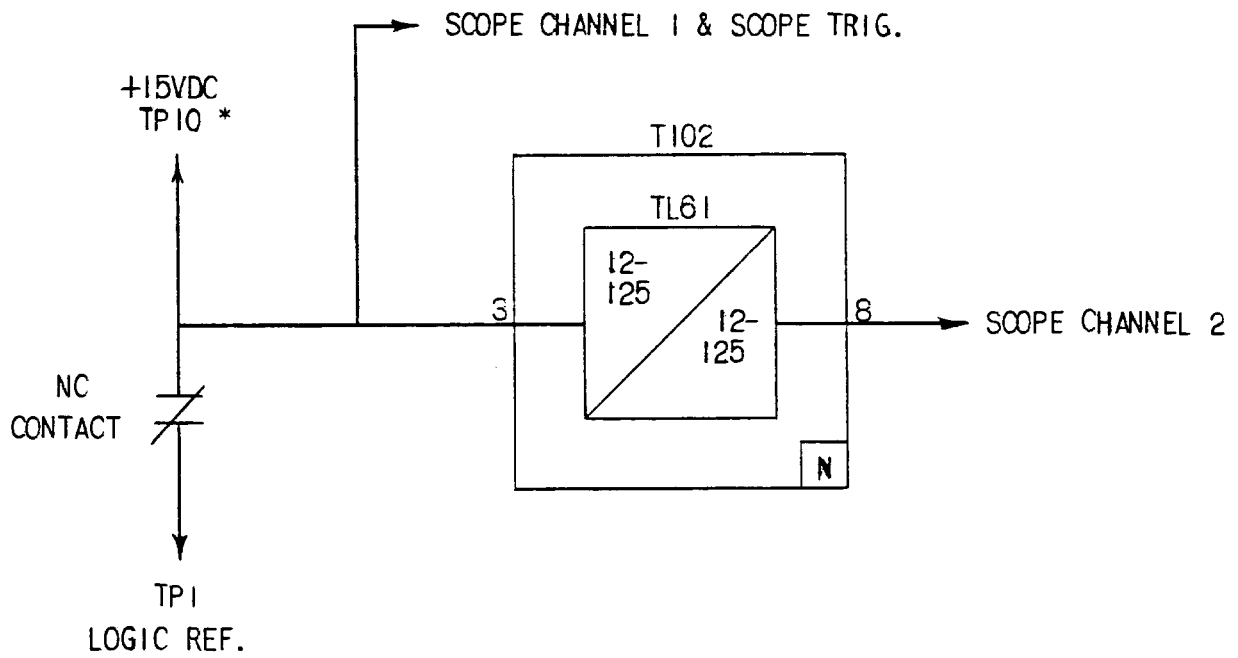

* THE 15VDC SIGNAL AT PIN 10 HAS A CURRENT LIMITING RESISTOR MOUNTED ON THE TEST CARD.

Figure 6 (0246A7987-0) Logic Timer Test Circuit

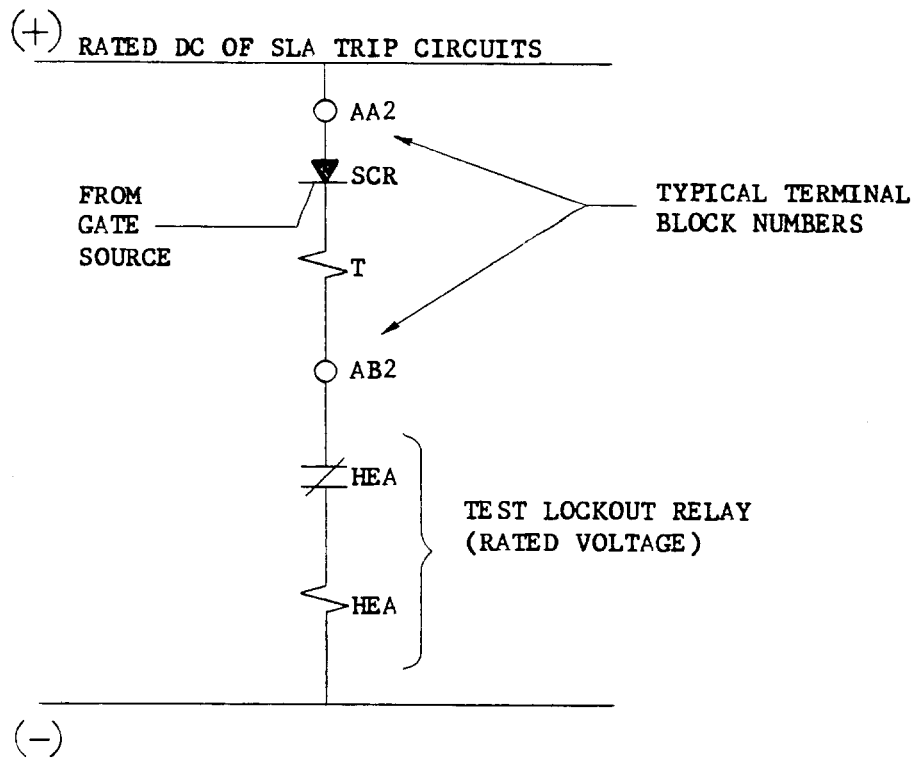

FIG. 7

TYPICAL SCR TEST CIRCUIT FOR TYPE SLA RELAYS

Figure 7 (0208A2365-0) Typical SCR Trip Circuit Test Connections



***Meter and Control
Business Department***

*General Electric Company
205 Great Valley Parkway
Malvern, PA 19355*