



# INSTRUCTIONS

GEK-65598

STATIC OUTPUT AND TRIPPING UNIT

TYPE SLAT51U

---

GENERAL  ELECTRIC

CONTENTS

	<u>PAGE</u>
DESCRIPTION .....	3
APPLICATION .....	3
RATINGS .....	4
BURDENS .....	4
SCR TRIP CIRCUIT .....	4
RI RECLOSE INITIATE CIRCUIT .....	4
BFI BREAKER FAILURE INITIATE CIRCUIT .....	5
V1 POSITIVE SEQUENCE VOLTAGE DETECTOR .....	5
OPTIONAL OUTPUTS .....	5
TARGETS .....	5
LOGIC CIRCUITS .....	5
CALCULATION OF SETTINGS .....	6
CONSTRUCTION .....	6
RECEIVING, HANDLING AND STORAGE .....	6
TEST INSTRUCTIONS .....	7
CAUTION .....	7
GENERAL .....	7
OPERATIONAL CHECKS .....	7
TEST CARD ADAPTER .....	7
TIMER ADJUSTMENTS AND TEST .....	7
TABLE I .....	8
TRIP CIRCUIT TESTS .....	8
OVERALL EQUIPMENT TESTS .....	8
MAINTENANCE .....	9
PERIODIC TESTS .....	9
TROUBLESHOOTING .....	9
SPARE PARTS .....	9

## STATIC OUTPUT AND TRIPPING UNIT

### TYPE SLAT51U

#### DESCRIPTION

The Type SLAT51U relay is a static output and tripping unit. The Type SLAT51U relay is not intended to be used by itself, but rather as part of a complement of equipment that forms a protective relaying scheme. For a complete description of the overall scheme in which this relay is employed, refer to the overall logic diagram and its associated logic description that is supplied with each terminal of equipment.

The Type SLAT51U relay is packaged in a two rack unit (one rack unit equals 1-3/4 inches) enclosed metal case suitable for mounting on a 19 inch rack. The outline and mounting dimensions are shown in Fig. 1. The internal connections for the SLAT51U relay are shown in Fig. 2. The component and card locations are shown in Fig. 3.

#### APPLICATION

The Type SLAT51U relay is a static output and tripping relay designed for use in various types of static relaying schemes. For example, the SLAT51U relay can be used in conjunction with types SLY, SLYG, SLC, SSA and SLA relays to make up a directional comparison pilot relaying scheme. Other schemes are also available in which the SLAT51U relay can be used. For a complete description of the particular scheme in which the SLAT51U relay is employed, refer to the overall logic diagram and description supplied with the scheme. The following is a listing of the various output functions included in the SLAT51U, together with a general description of their intended uses.

- SCR - Two silicon controlled rectifier trip circuits are provided to permit tripping of associated circuit breakers.
- RI - The reclose initiation outputs are provided to initiate automatic reclosing after a high speed trip.
- BFI - The breaker failure initiation outputs are provided for breaker failure protection.
- VI - The positive sequence voltage detector outputs are provided to permit voltage level monitoring or to provide an undervoltage alarm.
- RR1, RR2 - Optional reed relay contact outputs, the driving function of which may be selected from any of the number of logic points available in the associated SLA relay. The reed relay outputs are typically used for oscillograph start, data logging or other miscellaneous operations.

In addition to the above output functions, three target lamps are provided with each SLAT51U, and three more lamps can be provided as an option.

*These instructions do not purport to cover all details or variations in equipment nor to provide for every possible contingency to be met in connection with installation, operation or maintenance. Should further information be desired or should particular problems arise which are not covered sufficiently for the purchaser's purposes, the matter should be referred to the General Electric Company.*

*To the extent required the products described herein meet applicable ANSI, IEEE and NEMA standards; but no such assurance is given with respect to local codes and ordinances because they vary greatly.*

An adjustable timer, TL-32, can be provided as an option and it may be used to restrict target lamp indication in the function(s) that first operated. See the section under **CALCULATION OF SETTINGS** for further details and instructions for setting this timer.

### RATINGS

The Type SLAT51U relay is designed for use in an environment where the air temperature outside the relay case does not exceed minus 20°C and plus 65°C.

The Type SLAT51U relay requires a plus or minus 15 VDC power source which can be obtained from a Type SSA power supply.

The SCR tripping circuits are rated for 48/125 or 250 VDC. Each has a 1.0 ampere series target. The tripping circuits are designed to carry 30 amperes for one second.

The contacts of the telephone-type relays that are used for RI and V1 will make and carry three amperes continuously and will interrupt up to 0.5 ampere (inductive) at 125 VDC or 0.25 ampere (inductive) at 250 VDC.

The contacts of the reed relays that are used for BFI and options A and B are rated for 100 watts DC. They will make and carry three amperes continuously.

Refer to the unit nameplate for the ratings of a particular relay.

### BURDENS

The SLAT51U relay presents a maximum burden to the Type SSA power supply of:

335 ma from the +15 VDC supply  
75 ma from the -15 VDC supply

In addition, each target lamp draws 80 milliamperes from the minus 15 VDC power supply.

### SCR TRIP CIRCUIT

Two electrically separate, isolated SCR trip circuits are provided to trip two breakers. Each circuit is capable of carrying 30 amperes for one second.

The internal connections for the SCR trip and isolator subassemblies are shown in Fig. 4. The isolator card, by means of a DC-to-DC converter, provides a signal path, but maintains metallic isolation. This feature makes it possible to isolate the relay power supply from the trip circuit power supply.

### RI RECLOSE INITIATE CIRCUIT

Two electrically separate normally open contacts are provided. These contacts close within 17 milliseconds from the time the associated coil is energized by the logic. The contacts open within 170 milliseconds from the time the coil is de-energized. The RI function uses a telephone-type relay with contact ratings as stated under **RATINGS**.

### BFI BREAKER FAILURE INITIATE CIRCUIT

Two electrically separate normally open contacts are provided. These contacts close within two milliseconds from the time the associated coil is energized by the logic. These contacts open within two milliseconds from the time the coil is de-energized. The BFI function uses a reed relay with contact ratings stated under RATINGS.

### V1 - POSITIVE SEQUENCE VOLTAGE DETECTOR CIRCUIT

Three electrically separate contacts are provided, two normally open and one normally closed. These contacts operate within 17 milliseconds from the time the associated coil is energized by the logic. They reset within 17 milliseconds from the time the coil is de-energized. The V1 function uses a telephone-type relay with contact ratings stated under RATINGS.

### OPTIONAL OUTPUTS

Two optional reed relay contact outputs can be provided in either normally open or normally closed configuration. The contacts operate within two milliseconds from the time logic signals, available from the selected matrix points in the associated SLA, change state.

### TARGETS

Four electromechanical target coils are included, one in series with each SCR. These targets operate on one ampere of trip current when the associated SCR passes current. The trip circuit resistance in the relay is 0.40 ohm. Three target lamps are included and three additional lamps are available as options in the Type SLAT51U as shown on the internal connections diagram Fig. 2. Refer to the overall logic diagram for the scheme for the target lamps provided. When TL32 is provided, its output will prevent the target lamps from turning on. A long pickup setting on this timer will permit all functions that operate to light their associated lamps. A short time setting will allow only those functions that operate initially to be indicated.

### LOGIC CIRCUITS

The functions of the Type SLAT51U involve basic logic (AND, OR, and NOT) where the presence or absence of signals, rather than their magnitude, controls the operation. Signals are measured with respect to a reference bus accessible at TP1. In general, a signal below one VDC represents an OFF or LOGIC ZERO condition; an ON or LOGIC ONE is represented by a signal of approximately plus 15 VDC.

The symbols used on the internal connection diagram (Fig. 2) are explained by the legend shown in Fig. 5.

## CALCULATION OF SETTINGS

There is one optional timer function in the SLAT51U that requires field adjustment.

The 5-30/0 timer TL32 enables the user to control the number of lamps that will light under certain fault conditions. With a short pickup setting (five to ten milliseconds) only lamp(s) associated with those units which first sensed the fault will light. Increased pickup settings will cause the lamps associated with all units that operate to light. The timer setting should not exceed the minimum breaker clearing time in order to avoid targets which may result from breaker unequal pole opening times.

## CONSTRUCTION

The SLAT51U relay is packaged in an enclosed metal case with hinged front cover and removable top cover. The outline and mounting dimensions of the case and the physical location of the components are shown in Fig. 1 and 3, respectively.

The SLAT51U relay contains printed circuit cards identified by a code number, such as A104, T106, L109; where A designates auxiliary function, T designates a time-delay function, and L designates a logical function. The printed circuit cards plug in from the front of the unit. The sockets are marked with letter designations or "addresses" (D, E, F, etc.) which appear on the guide strips in front of each socket, on the component location drawing, on the unit internal connection diagram, and on the printed circuit card. The test points (TP1, TP2, etc.) shown on the internal connection diagram are connected to instrument jacks on a test card in position T with TP1 at the top of the T card. TP1 is tied to reference; TP10 is tied to plus 15 VDC through a 1.5K resistor. This resistor limits the current when TP10 is used to supply a logic signal to a card.

## RECEIVING, HANDLING AND STORAGE

These relays will normally be supplied as a part of a static relay equipment, mounted in a rack or cabinet with other static relays and test equipment. Immediately upon receipt of a static relay equipment, it should be unpacked and examined for any damage sustained in transit. If injury or damage resulting from rough handling is evident, file a damage claim at once with the transportation company and promptly notify the nearest General Electric Sales Office.

Reasonable care should be exercised in unpacking the equipment. If the equipment is not to be installed immediately, it should be stored indoors in a location that is free from moisture, dust, metallic chips, and severe atmospheric contaminants.

Just prior to final installation the shipping support bolt should be removed from each side of all relay units, to facilitate possible future unit removal for maintenance. These shipping support bolts are approximately eight inches back from the relay front panel. Static relay equipment, when supplied in swing rack cabinets, should be securely anchored to the floor or to the shipping pallet to prevent the equipment from tipping over when the swing rack is opened.

## TEST INSTRUCTIONS

### CAUTION

IF THE SLAT51U RELAY TO BE TESTED IS PART OF A COMPLETE RELAY TERMINAL EQUIPMENT IN SERVICE, THE VARIOUS OUTPUTS FROM THE SLAT51U MUST BE DISCONNECTED PRIOR TO ANY TEST.

### GENERAL

The SLAT51U relay is supplied from the factory either mounted in a static relay equipment or as a separate unit associated with measuring relays, a Type SSA power supply, and some form of channel equipment. All relay units for a given terminal of static relaying equipment are tested together at the factory, and each unit will have the same summary number stamped on its nameplate.

In general, when a time range is indicated on the internal connections diagram, the timer has been factory set at a mid-range value. Timers should be set for the operating or reset times indicated on the associated overall logic diagram. Where a time range is indicated on the overall logic diagram, the timer should be set for the value recommended for that function in the descriptive write-up accompanying the overall logic diagram. Where a setting depends upon conditions encountered on a specific application, this is so stated and the factors influencing the choice of setting are described. The procedure for checking and setting the timers is described in a later section.

### OPERATIONAL CHECKS

Operation of the SLAT51U unit can be checked by observing the signals at the ten test points (TP1 to TP10) in the SLAT51U, by observing the operation of the associated channel equipment, or by observing the output functions. The test points are located on one test card in position T, and are numbered 1 to 10 from top to bottom. TP1 is the reference bus for the logic circuit; TP10 is at plus 15 VDC. The remaining points are located at various strategic points throughout the logic as shown on the internal connection diagram (Fig. 2). Test point voltages can be monitored with a portable high impedance voltmeter, the voltmeter on the test panel of the associated equipment, or an oscilloscope.

### TEST CARD ADAPTER

The test card adapter provides a convenient means of gaining access to any pin of a particular card. Detailed information on the use of the test adapter card is included in the card instruction book, GEK-34158.

### TIMER ADJUSTMENTS AND TESTS

When the time-delay cards are to be adjusted or checked, an oscilloscope that can display two traces simultaneously, and that has a calibrated horizontal sweep, should be used.

In order to test the timer cards it is necessary to remove the card previous to the timer (see Table I) and to place the timer card in a card adapter. The card adapter allows access to the input and output of the timer if they are not brought out on test points. The timer test circuit is shown in Fig. 6. Opening the normally closed contact causes the output to step up to plus 15 VDC after the pickup delay of the timer. To increase the pickup time, turn the upper potentiometer on the timer card clockwise; to decrease the time, turn it counterclockwise. Closing the contact causes the timer output to drop out after the reset time-delay setting of the card. If the timer card is provided with a variable reset delay, it can be adjusted by the lower potentiometer on the timer card (clockwise increases reset time).

TABLE I

TIMER UNDER TEST	POSITION	REMOVE CARD IN POSITION
TL31	F	NONE **
TL32	H	G ***

\*\* Turn power supply switch on and off  
 \*\*\* Refer to overall logic diagram for functions in associated units which should be removed.

TRIP CIRCUIT TESTS

The SCR trip circuits and the series mechanical targets may be checked by connecting an auxiliary lock-out relay, such as the Type HEA relay, in series with the SCR circuit. A typical circuit is shown in Fig. 7. The HEA relay should have the same DC rating as the SCR trip circuit of the SLAT51U. If an auxiliary lock-out relay is not available, it can be replaced by a resistive load which limits the trip circuit current to three amperes. In most equipments, the SCR can be gated by operating a test push button in the associated units.

Prior to final installation, a check of the overall trip circuit should be made with the SCR outputs connected to trip the circuit breakers.

OVERALL EQUIPMENT TESTS

After the SLAT51U relay and the associated static relay units have been individually calibrated and tested for the desired settings, a series of overall operating circuit checks is advisable.

The elementary, overall logic and logic description for the specific job will be useful for determining the overall operation of the scheme.

Overall equipment tests can be performed by applying AC current and voltages to the measuring units as specified in the instruction book for the measuring units and checking that proper outputs are obtained when the measuring units operate.



## MAINTENANCE

### PERIODIC TESTS

It should be sufficient to check the outputs produced at test points in the SLAT51U when periodic calibration tests are made on the associated measuring units, for example, the phase and ground relays in line-relaying scheme. No separate periodic tests on the SLAT51U itself should be required.

### TROUBLESHOOTING

In any troubleshooting of equipment, it should first be established which unit is functioning incorrectly. The overall logic diagram supplied with the equipment shows the combined logic of the complete equipment and the various test points in each unit. By signal tracing, using the overall logic diagram and the various test points, it should be possible to quickly isolate the trouble.

A test adapter card is supplied with each static relay equipment to supplement the prewired test points on the test cards. Use of the adapter card is described in the card instruction book, GEK-34158.

A dual trace oscilloscope is a valuable aid to detailed troubleshooting, since it can be used to determine phase shift, operate and reset times, as well as input and output levels. A portable dual-trace oscilloscope with a calibrated sweep and trigger facility is recommended.

### SPARE PARTS

To minimize possible outage time, it is recommended that a complete maintenance program should include the stocking of a least one spare card of each type. It is possible to replace damaged or defective components on the printed circuit cards, but great care should be taken in soldering so as not to damage or bridge-over the printed circuit buses, or overheat the semiconductor components. The repaired area should be recovered with a suitable high-dielectric plastic coating to prevent possible breakdowns across the printed buses due to moisture and dust. The wiring diagrams for the cards in the SLAT51U relay are included in the card book, GEK-34158.



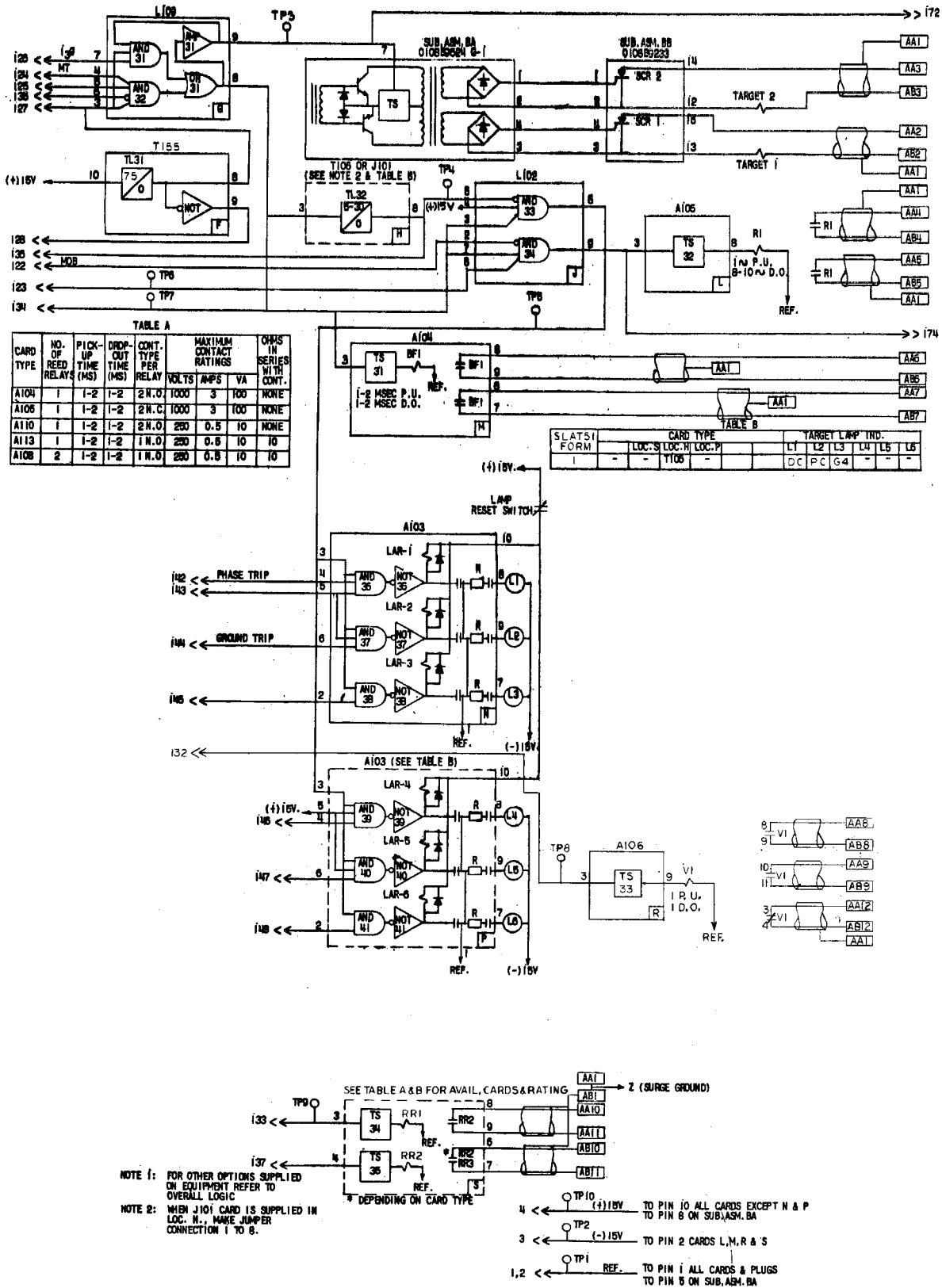
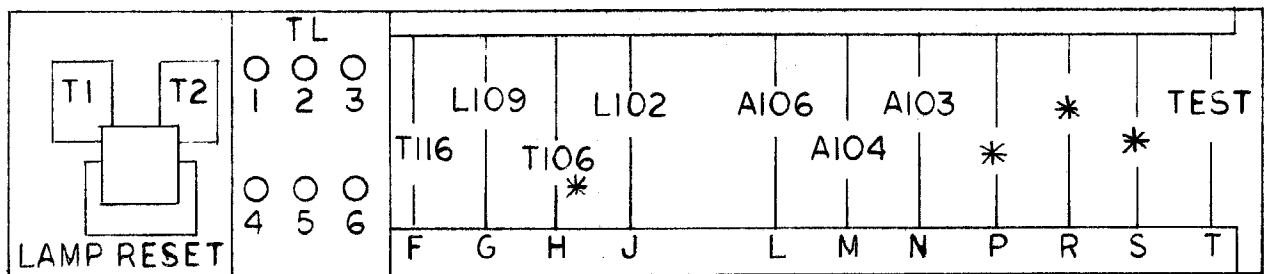
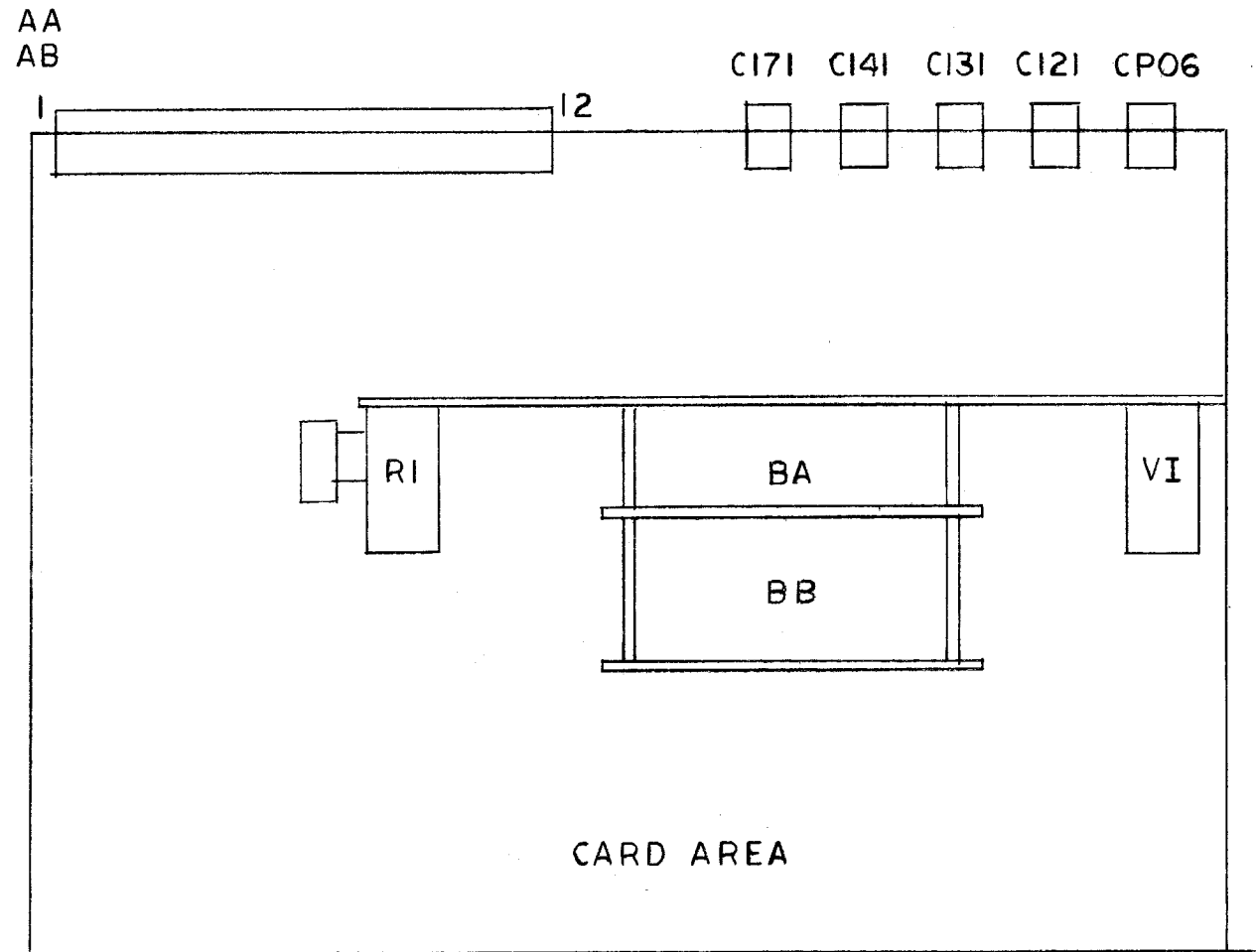
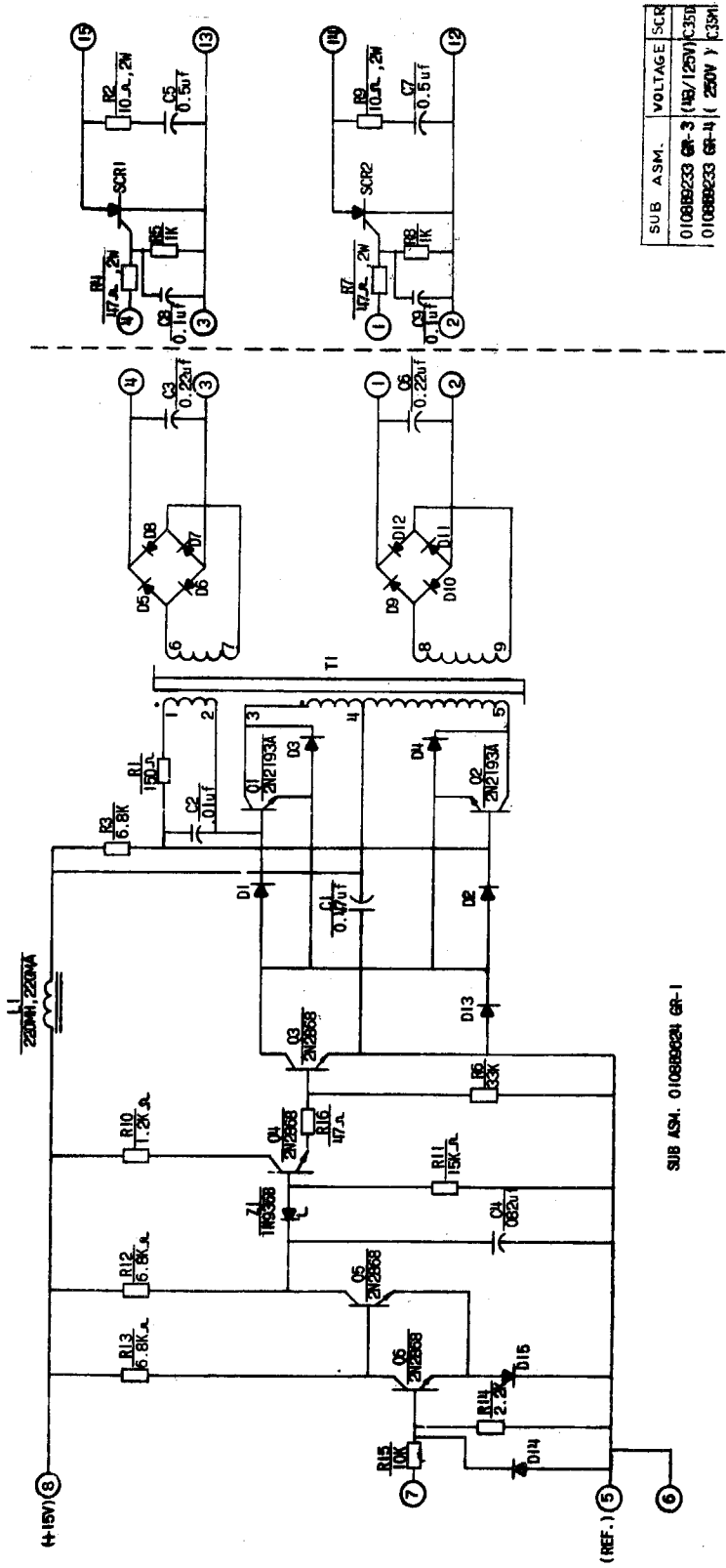

Fig. 2 (0179C6120-0) Internal Connections for the SLAT51U Relay



\* OPTIONAL, REFER TO UNIT INTERNAL CONNECTIONS

Fig. 3 (0285A5664-0) Component Locations for the SLAT51U Relay



SUB ASM.	VOLTAGE	SCR
0108B9233 GR-3	(18/125V)	C35H
0108B9233 GR-4	(250V)	J35H

ALL DIODES INH180 UNLESS NOTED  
 ALL RES. 1/2 WATT ±5% UNLESS NOTED  
 (2) = TERM. POST ON BOARD ASM  
 IN6358 = 9.1V ±5%

SUB ASM. 0108B9233 GR-1

Fig. 4 (0108B9610-0) Internal Connections for SCR Trip and Isolator Subassemblies

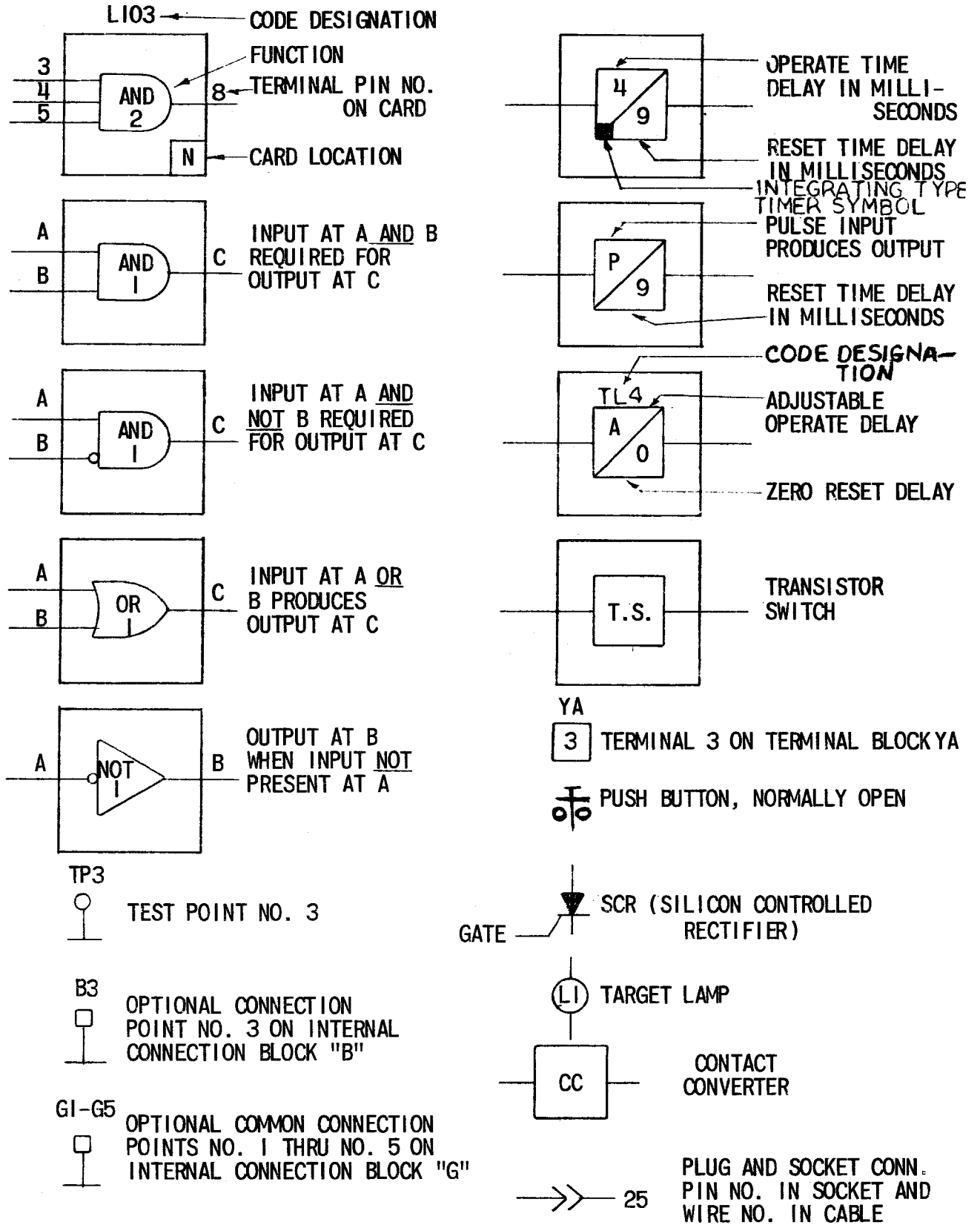
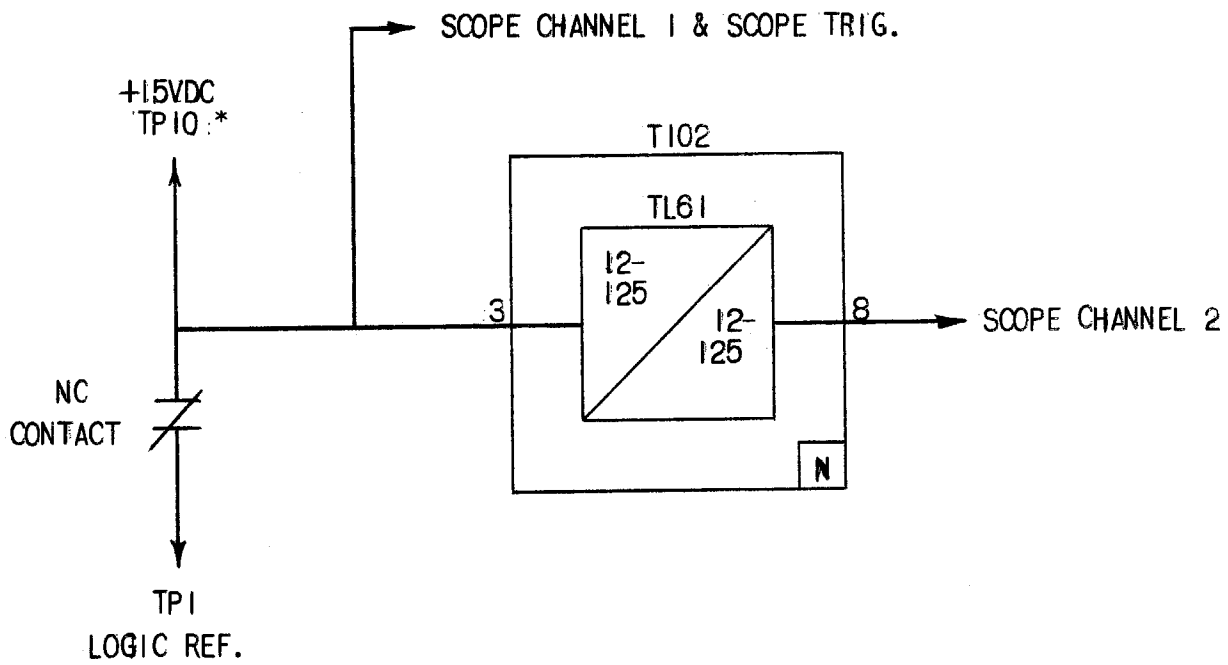
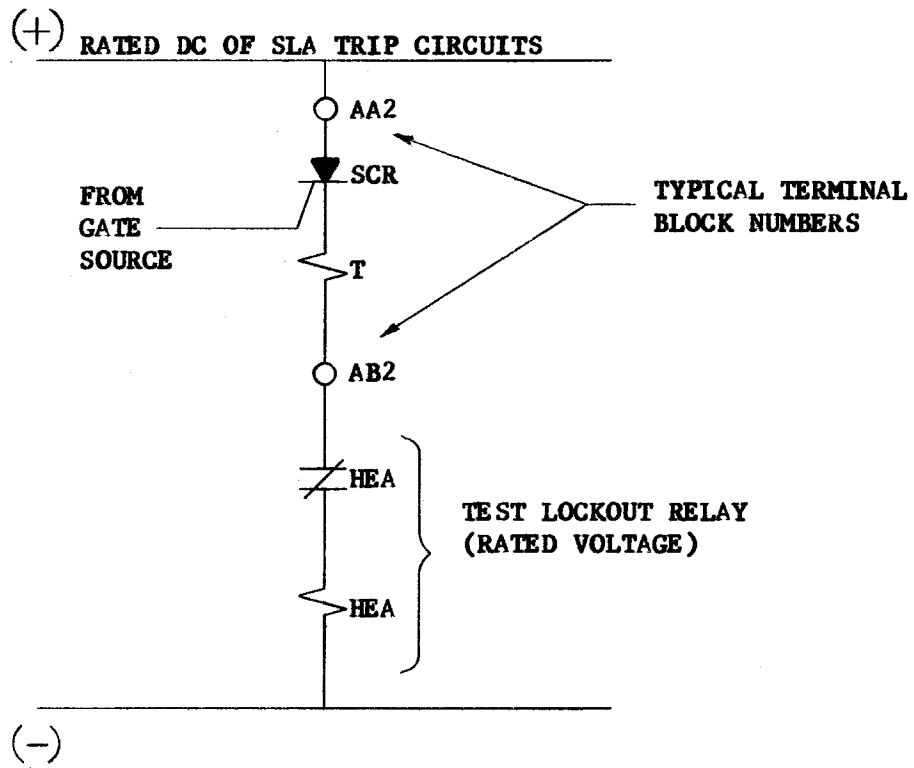

Fig. 5 (0227A2047-1) Logic and Internal Connection Legend



\* THE 15VDC SIGNAL AT PIN 10 HAS A CURRENT LIMITING RESISTOR MOUNTED ON THE TEST CARD.

Fig. 6 (0246A7987-0) Logic Timer Test Circuit



**FIG. 7**

**TYPICAL SCR TEST CIRCUIT FOR TYPE SLA RELAYS**

Fig. 7 (0208A2365-0) Typical SCR Trip Circuit Test Connections