



INSTRUCTIONS

GEK-86048

**STATIC OUTPUT AND TRIPPING UNIT
TYPE SLAT53K**

GENERAL  ELECTRIC

CONTENTS

	<u>PAGE</u>
DESCRIPTION	3
APPLICATION	3
SCR	3
RI-1Ø	3
TX	3
OSC	3
TARGETS	4
RATINGS	4
BURDENS	4
FUNCTIONS	4
SCR TRIP CIRCUIT (TA, TB, TC)	4
RI-1Ø SINGLE POLE RECLOSE INITIATE CIRCUIT	5
TX	5
OSC	5
TARGETS	5
LOGIC CIRCUITS	5
CONSTRUCTION	6
RECEIVING, HANDLING AND STORAGE	6
TEST INSTRUCTIONS	7
CAUTION	7
GENERAL	7
OPERATIONAL CHECKS	7
TEST CARD ADAPTER	7
TIMER ADJUSTMENTS AND TESTS	8
TRIP CIRCUIT TESTS	8
OVERALL EQUIPMENT TESTS	8
MAINTENANCE	8
PERIODIC TESTS	8
TROUBLESHOOTING	9
SPARE PARTS	9

STATIC OUTPUT AND TRIPPING UNIT

TYPE SLAT53K

DESCRIPTION

The SLAT53K relay is a static output and tripping unit for transmission line protection schemes utilizing single pole tripping and reclosing. The relay is packaged in a four rack unit (one rack unit equals 1-3/4 inches) enclosed metal case suitable for 19-inch wide rack mounting. The case outline and mounting dimensions are shown in Figure 1. The internal connections for the SLAT53K are shown in Figure 2. The component and printed circuit card locations are shown in Figure 3.

APPLICATION

The SLAT53K relay is designed to operate in conjunction with SLY, SLYG and SLC measuring relays in a single pole tripping directional comparison scheme. For a complete description of the overall scheme in which the relay is employed, refer to the logic diagram and its associated logic description supplied with a specific equipment.

The following is a listing of the various output functions and their intended uses:

SCR

There are two silicon controlled rectifier trip circuits per phase to permit tripping individual poles of the associated line breakers directly for single phase-to-ground faults.

RI-1Ø

Two normally open contact outputs are provided to initiate automatic reclosing after a single pole trip.

TX

Three normally open contacts are provided per phase to operate the reactor trip switch and early valving circuits. These contacts close five milliseconds after the trip bus for either phase is energized.

OSC

A high speed oscillograph start relay is included with two normally open and one normally closed contacts which operate within two milliseconds after any trip bus is energized.

These instructions do not purport to cover all details or variations in equipment nor to provide for every possible contingency to be met in connection with installation, operation or maintenance. Should further information be desired or should particular problems arise which are not covered sufficiently for the purchaser's purposes, the matter should be referred to the General Electric Company.

To the extent required the products described herein meet applicable ANSI, IEEE and NEMA standards; but no such assurance is given with respect to local codes and ordinances because they vary greatly.

TARGETS

A current-operated hand reset electromechanical target is included in each of the six SCR trip circuits and six TX output circuits.

RATINGS

The Type SLAT53K relay is designed for use in an environment where the air temperature outside the relay case is between minus 20°C and plus 65°C.

The Type SLAT53K relay requires a plus or minus 15 VDC power source which can be obtained from a Type SSA power supply.

The tripping circuits are rated for 48/125 or 250 VDC. Each has a 1.0 ampere series target. The tripping circuits are designed to carry 30 amperes for one second.

The contacts of the telephone-type relays that are used for RI-1Ø and TX will make and carry three amperes continuously. They will make and carry 30 amperes for tripping duty. The contacts will interrupt 180 volt-amperes resistive (60 volt-amperes inductive).

The contacts of the reed relays that are used for OSC will make and carry three amperes continuously or short time. The contacts will interrupt 100 volt-amperes resistive (35 volt-amperes inductive). These contacts will carry 15 amperes for one-half second if this loading is applied after closing the contacts on less than the rated closing current.

Refer to the unit nameplate for the ratings of a particular relay.

BURDENS

The SLAT53K relay presents a maximum burden to the Type SSA power supply of:

225 milliamperes from the plus 15 VDC supply
170 milliamperes from the minus 15 VDC supply

Each contact converter, when energized, will draw approximately ten milliamperes from the station battery, regardless of tap setting.

FUNCTIONS

SCR TRIP CIRCUIT (TA, TB, TC)

Electrically separate, isolated SCR trip circuits are provided. Each circuit is capable of carrying 30 amperes for one second.

The internal connections for the SCR trip and isolator subassemblies are shown in Figure 4. The isolator card, by means of a DC-to-DC converter, provides a signal path but maintains metallic isolation. This feature makes it possible to isolate the relay power supply from the trip circuit power supply.

RI-1Ø - SINGLE POLE RECLOSE INITIATE CIRCUIT

Two electrically separate Form C contacts are provided. These contacts close within eight milliseconds from the time the associated coil is energized by the logic. The contacts open within 16-32 milliseconds from the time the coil is de-energized. The RI-1Ø function uses a telephone-type relay with contact ratings stated under **RATINGS**.

TX

Three electrically separate normally open contacts are provided per phase. These contacts close five milliseconds after the associated trip bus is energized by the logic. The TX function uses a telephone-type relay with contact ratings stated under **RATINGS**.

OSC

Two electrically separate normally open contacts, and one normally closed contact are provided. These contacts close within two milliseconds from the time that the associated coil is energized by the logic. The contacts open within two milliseconds from the time the coil is de-energized. The OSC function uses reed relays with contact ratings stated under **RATINGS**.

TARGETS

Twelve electromechanical target coils are included. One target is in series with each SCR; these targets operate on one ampere of trip current when the associated SCR passes current. An electromechanical target coil is in series with two of the TX contacts for each phase.

LOGIC CIRCUITS

The functions of the Type SLAT53K relay involve basic logic (AND, OR, and NOT) where the presence or absence of signals, rather than their magnitude, controls the operation. Signals are measured with respect to a reference bus accessible at TP1. In general, a signal below one VDC represents an OFF or LOGIC ZERO condition, an ON or LOGIC ONE state is represented by a signal of approximately plus or minus 15 VDC.

The symbols used on the internal connection diagram (Figure 2) are explained by the legend shown in Figure 5.

CONSTRUCTION

The SLAT53K relay is packaged in an enclosed metal case with hinged front cover and removable top cover. The outline and mounting dimensions of the case and the physical location of the components are shown in Figure 1 and 3, respectively.

The SLAT53K relay contains printed circuit cards identified by a code number, such as: A104, T132, L105; where A designates an auxiliary function, T designates a timing function, and L designates a logic function. The printed circuit cards plug in from the front of the unit. The sockets are marked with letter designations or "addresses" (D, E, F, etc.) which appear on the guide strips in front of each socket, on the component location drawing, on the unit internal connection diagram, and on the printed circuit card. The test points (TP1, TP2, etc.) shown on the internal connection diagram are connected to instrument jacks on a test card in position T or AT with TP1 at the top of the AT card. TP1 is tied to reference; TP10 is tied to plus 15 VDC through a 22K resistor. This resistor limits the current when TP10 is used to supply a logic signal to a card.

The SLAT53K relay receives its inputs from the associated Type SLA and SLAT relays. These units are interconnected by ten-conductor shielded cables. The sockets for these cables are located on the rear panel of the unit. The SLAT53K output functions are connected to 12-point terminals strips, which are also located on the rear of the unit.

A window is provided in the hinged cover of the relay to allow the mechanical targets to be seen. Push buttons are also provided to reset the targets without opening the cover.

RECEIVING, HANDLING AND STORAGE

These relays will normally be supplied as part of a static relay equipment, mounted in a rack or cabinet with other static relays and test equipment. Immediately upon receipt of a static relay equipment, it should be unpacked and examined for any damage sustained in transit. If injury or damage resulting from rough handling is evident, file a damage claim at once with the transportation company and promptly notify the nearest General Electric Sales Office.

Reasonable care should be exercised in unpacking the equipment. If the equipment is not to be installed immediately, it should be stored indoors in a location that is free from moisture, dust, metallic chips, and severe atmospheric contaminants.

Just prior to final installation the shipping support bolt should be removed from each side of all relay units, to facilitate possible future unit removal for maintenance. These shipping support bolts are approximately eight inches back from the relay front panel.

WARNING: STATIC RELAY EQUIPMENT, WHEN SUPPLIED IN SWING RACK CABINETS, SHOULD BE SECURELY ANCHORED TO THE FLOOR OR TO THE SHIPPING PALLET TO PREVENT THE EQUIPMENT FROM TIPPING OVER WHEN THE SWING RACK IS OPENED.

TEST INSTRUCTIONS

If the SLAT53K relay that is to be tested is installed in an equipment which has already been connected to the power system, disconnect the outputs to the system.

CAUTION

THE LOGIC SYSTEM SIDE OF THE DC POWER SUPPLY USED WITH MOD III STATIC RELAY EQUIPMENT IS ISOLATED FROM GROUND. IT IS A DESIGN CHARACTERISTIC OF MOST ELECTRONIC INSTRUMENTS THAT ONE OF THE SIGNAL INPUT TERMINALS IS CONNECTED TO THE INSTRUMENT CHASSIS. IF THE INSTRUMENT USED TO TEST THE RELAY EQUIPMENT IS ISOLATED FROM GROUND, ITS CHASSIS MAY HAVE A ELECTRICAL POTENTIAL WITH RESPECT TO GROUND. THE USE OF A TEST INSTRUMENT WITH A GROUNDED CHASSIS WILL NOT AFFECT THE TESTING OF THE EQUIPMENT. HOWEVER, A SECOND GROUND CONNECTION TO THE EQUIPMENT, SUCH AS A TEST LEAD INADVERTENTLY DROPPING AGAINST THE RELAY CASE, MAY CAUSE DAMAGE TO THE LOGIC CIRCUITRY. NO EXTERNAL TEST EQUIPMENT SHOULD BE LEFT CONNECTED TO THE STATIC RELAYS WHEN THEY ARE IN PROTECTIVE SERVICE, SINCE TEST EQUIPMENT GROUNDING REDUCES THE EFFECTIVENESS OF THE ISOLATION PROVIDED.

GENERAL

The SLAT53K relay is supplied from the factory either mounted in a static relay equipment or as a separate unit associated with measuring relays, a Type SSA power supply, and some form of channel equipment. All relay units for a given terminal of static relaying equipment are tested together at the factory, and each unit will have the same summary number stamped on its nameplate.

Timers should be set for operating or reset times indicated on the associated overall logic diagram. Where a time range is indicated on the overall logic diagram, the timer should be set for the value recommended for that function in the descriptive writeup accompanying the overall logic diagram. Where a setting depends upon conditions encountered on a specific application, this is so stated and the factors influencing the choice of setting are described. The procedure for checking and setting the timers is described in a later section.

OPERATIONAL CHECKS

Operation of the SLAT53K unit can be checked by observing the signals at the twenty test points (TP1 to TP20) in the SLAT53K, by observing the operation of the associated channel equipment, or by observing the output functions. The test points are located on two test cards in positions T and AT and are numbered 1 to 20 from top to bottom. TP1 is the reference bus for the logic circuit; TP10 is at plus 15 VDC. The remaining points are located at various strategic points throughout the logic as shown on the internal connection diagram (Figure 2). Test point voltages can be monitored with a portable high impedance voltmeter, the voltmeter on the test panel of the associated equipment, or an oscilloscope.

TEST CARD ADAPTER

The test card adapter provides a convenient means of gaining access to any pin of a particular card. Detailed information on the use of the test card adapter is included in the card instruction book, GEK-34158.

TIMER ADJUSTMENTS AND TESTS

When the time-delay cards are to be adjusted or checked, an oscilloscope that can display two traces simultaneously and has a calibrated horizontal sweep, should be used.

In order to test the timer cards it is necessary to remove the card which supplied the input to the timer and to place the timer card in a card adapter. The card adapter allows access to the input and output of the timer if they are not brought out on test points. A typical timer test circuit is shown in Figure 6. Opening the normally closed contact causes the output to step up to plus 15 VDC after the pickup delay of the timer. To increase the pickup time, turn the upper potentiometer on the timer card clockwise; to decrease the time, turn it counterclockwise. Closing the contact causes the timer output to drop out after the reset time-delay setting of the card. If the timer card is provided with a variable reset delay, it can be adjusted by the lower potentiometer on the timer card (clockwise increases reset time).

TRIP CIRCUIT TESTS

The SCR trip circuits and the series mechanical targets may be checked by connecting an auxiliary lock-out relay, such as the Type HEA relay, in series with the SCR circuit. A typical circuit is shown in Figure 7. The HEA relay should have the same DC rating as the SCR trip circuit of the SLAT53K. If an auxiliary lock-out relay is not available, it can be replaced by a resistive load which limits the trip circuit current to three amperes.

Prior to final installation, a check of the overall trip circuit should be made with the SCR outputs connected to trip the circuit breakers.

OVERALL EQUIPMENT TESTS

After the SLAT53K relay and the associated static relay units have been individually calibrated and tested for the desired settings, a series of overall operating circuit checks is advisable.

The elementary, overall logic and logic description for the specific job will be useful for determining the overall operation of the scheme.

Overall equipment tests can be performed by applying alternating currents and voltages to the measuring units as specified in the instruction book for the measuring units and checking that proper outputs are obtained when the measuring units operate.

MAINTENANCEPERIODIC TESTS

It should be sufficient to check the outputs produced at test points in the SLAT53K when periodic calibration tests are made on the associated measuring units. For example, the phase and ground relays in line-relaying scheme. No separate periodic tests on the SLAT53K itself should be required.

TROUBLESHOOTING

In any troubleshooting of equipment, it should first be established which unit is functioning incorrectly. The overall logic diagram supplied with the equipment shows the combined logic of the complete equipment and the various test points in each unit. By signal tracing, using the overall logic diagram and the various test points, it should be possible to quickly isolate the trouble.

A test adapter card is supplied with each static relay equipment to supplement the prewired test points on the test cards. Use of the adapter card is described in the card instruction book, GEK-34158.

A dual trace oscilloscope is a valuable aid to detailed troubleshooting, since it can be used to determine phase shift, operate and reset times, as well as input and output levels. A portable dual-trace oscilloscope with a calibrated sweep and trigger facility is recommended.

SPARE PARTS

To minimize possible outage time, it is recommended that a complete maintenance program should include the stocking of a least one spare card of each type. It is possible to replace damaged or defective components on the printed circuit cards, but great care should be taken in soldering so as not to damage or bridge-over the printed circuit buses, or overheat the semiconductor components. The repaired area should be recovered with a suitable high-dielectric plastic coating to prevent possible breakdowns across the printed buses due to moisture and dust. The wiring diagrams for the cards in the SLAT53K relay are included in the card book, GEK-34158.

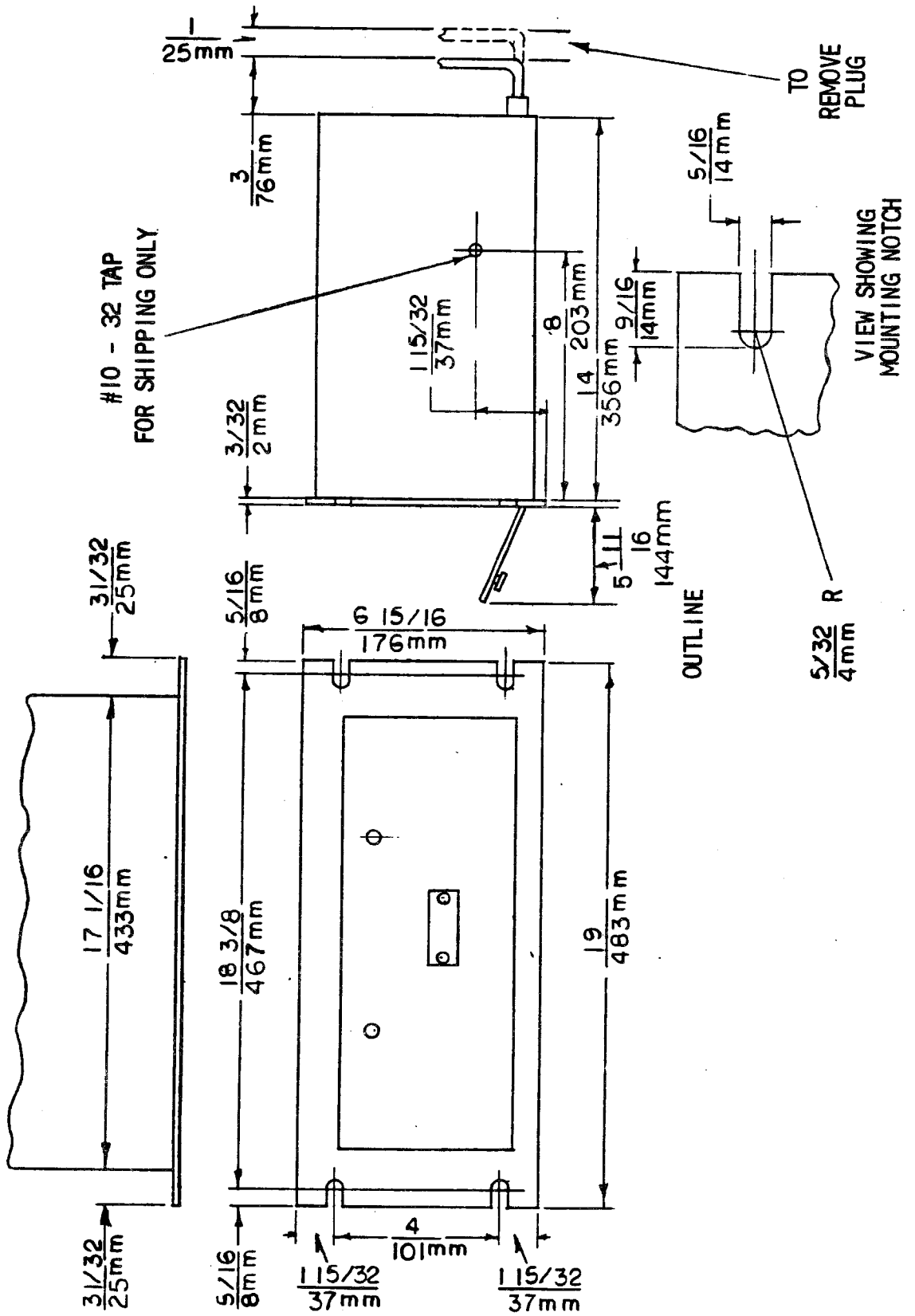
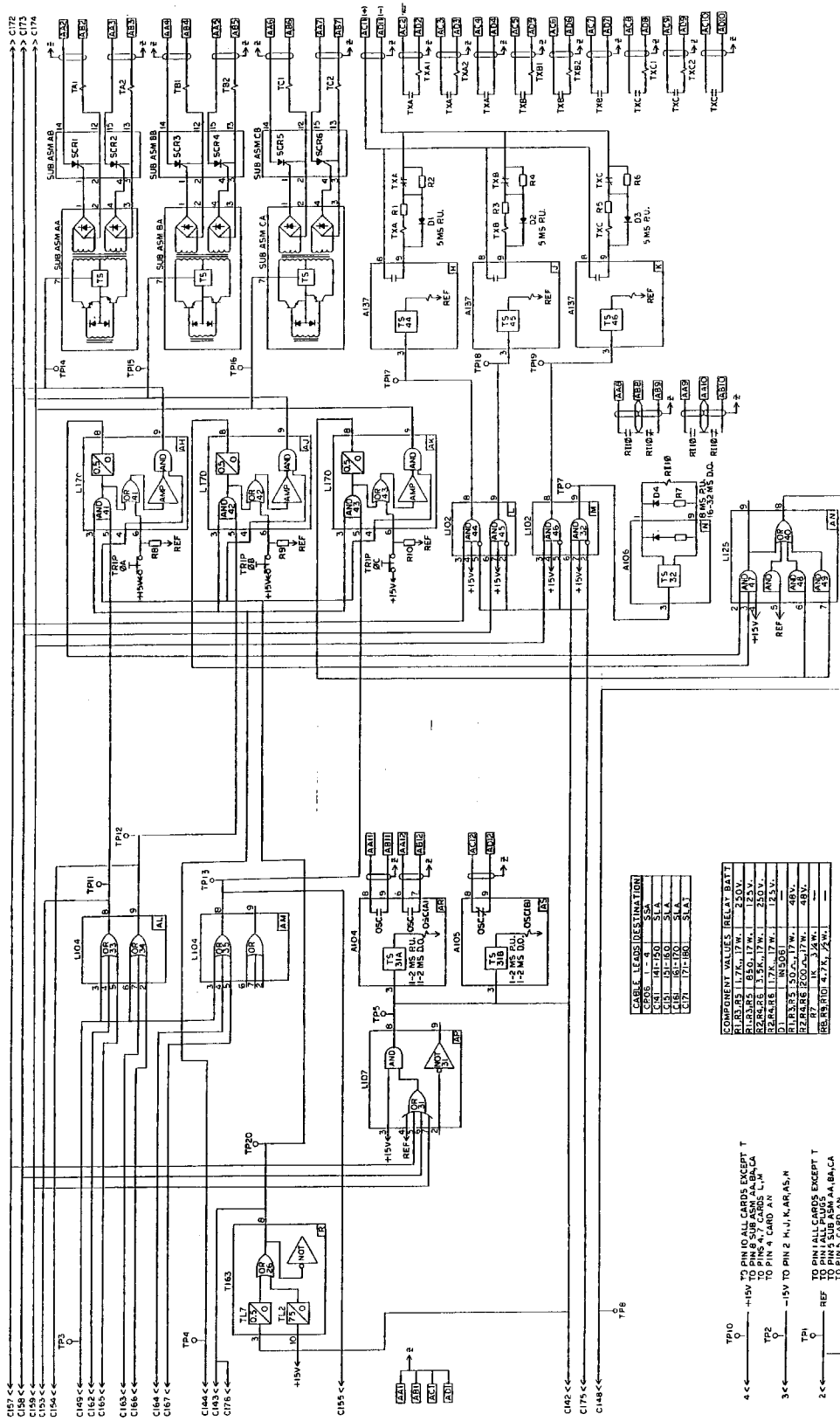

Figure 1 (0227A2037-0) Outline and Mounting Dimensions



CABLE LEADS DESTINATION

C198	1-4	SLA
C199	1-10	SLA
C200	1-10	SLA
C201	1-10	SLA
C202	1-10	SLA
C203	1-10	SLA
C204	1-10	SLA
C205	1-10	SLA
C206	1-10	SLA
C207	1-10	SLA
C208	1-10	SLA
C209	1-10	SLA
C210	1-10	SLA

COMPONENT VALUES RELAT BATT

R1, R2, R3	1.7K, 17W	250V
R4, R5, R6, R7, R8, R9, R10	1.5K, 17W	250V
R11, R12, R13, R14, R15, R16, R17, R18, R19, R20	1.7K, 17W	125V
R21, R22, R23, R24, R25, R26, R27, R28, R29, R30	1.5K, 17W	250V
R31, R32, R33, R34, R35, R36, R37, R38, R39, R40	1.7K, 17W	125V
R41, R42, R43, R44, R45, R46, R47, R48, R49, R50	1.5K, 17W	250V
R51, R52, R53, R54, R55, R56, R57, R58, R59, R60	1.7K, 17W	125V
R61, R62, R63, R64, R65, R66, R67, R68, R69, R70	1.5K, 17W	250V
R71, R72, R73, R74, R75, R76, R77, R78, R79, R80	1.7K, 17W	125V
R81, R82, R83, R84, R85, R86, R87, R88, R89, R90	1.5K, 17W	250V
R91, R92, R93, R94, R95, R96, R97, R98, R99, R100	1.7K, 17W	125V

- TP10 0 +15V TO PIN1 ALL CARDS EXCEPT T TO PINS 4, 5, 6, 7, 8, 9, 10
- TP2 1 -15V TO PIN 4 CARD AN
- TP1 0 REF TO PIN1 ALL CARDS EXCEPT T TO PINS 2, 3, 4, 5, 6, 7, 8, 9, 10
- TP3 0 REF TO PIN5 CARD AN TO PINS 5, 6, 7, 8, 9, 10
- TP4 0 REF TO PIN4 CARD AN TO PINS 4, 5, 6, 7, 8, 9, 10

Figure 2 (0145D8794-0) Internal Connections for the Type SLAT53K Relay

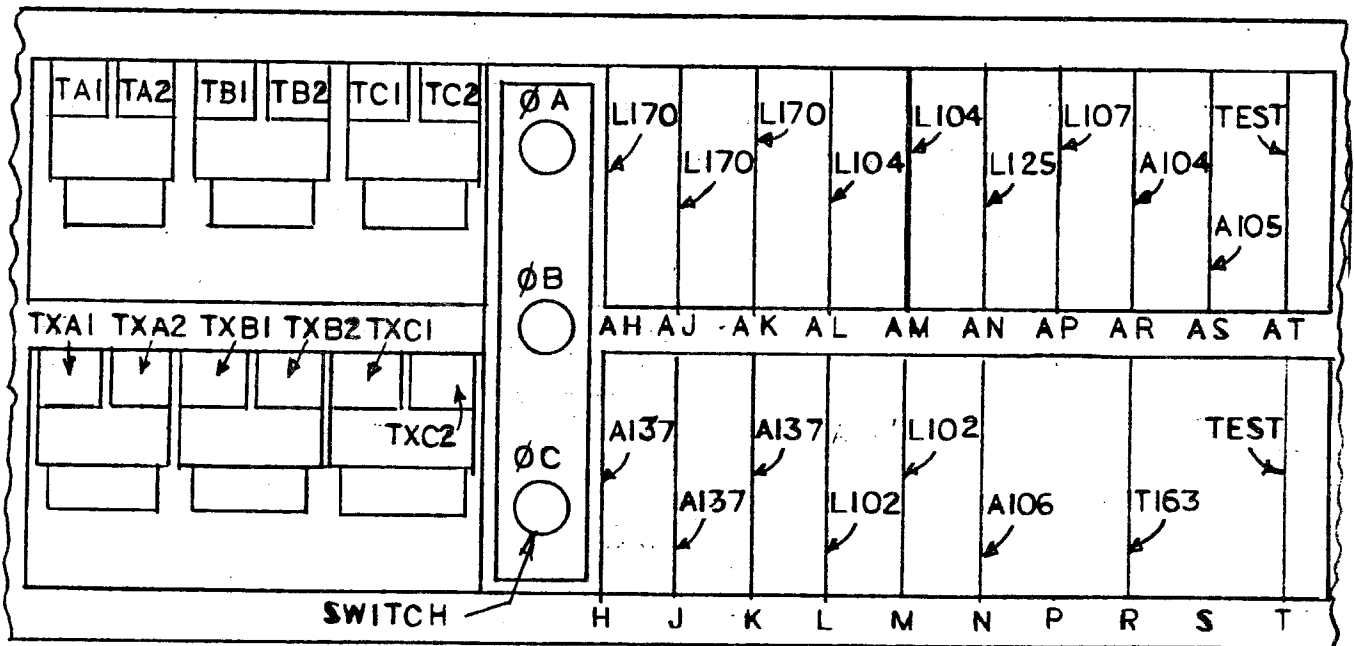
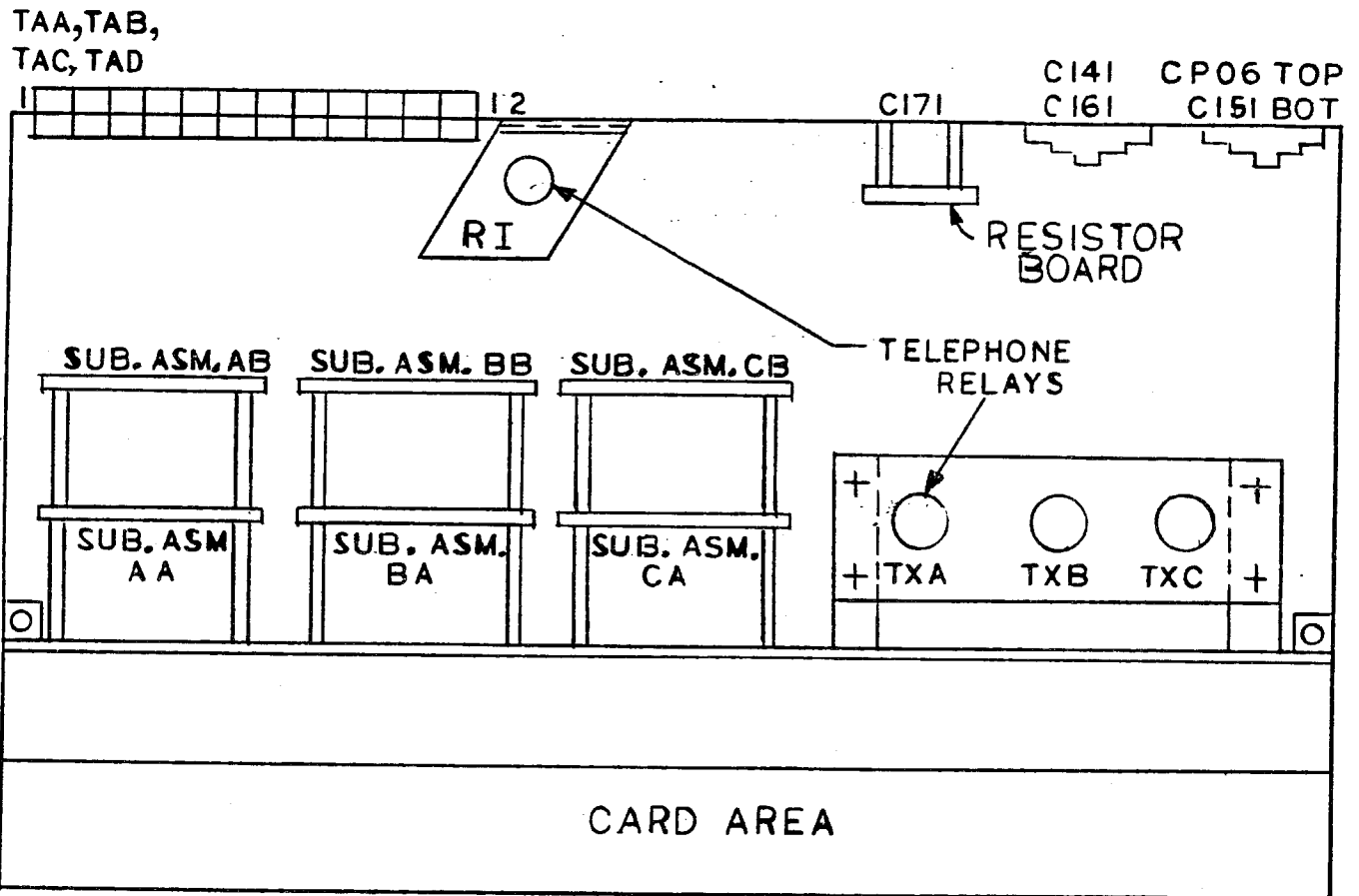
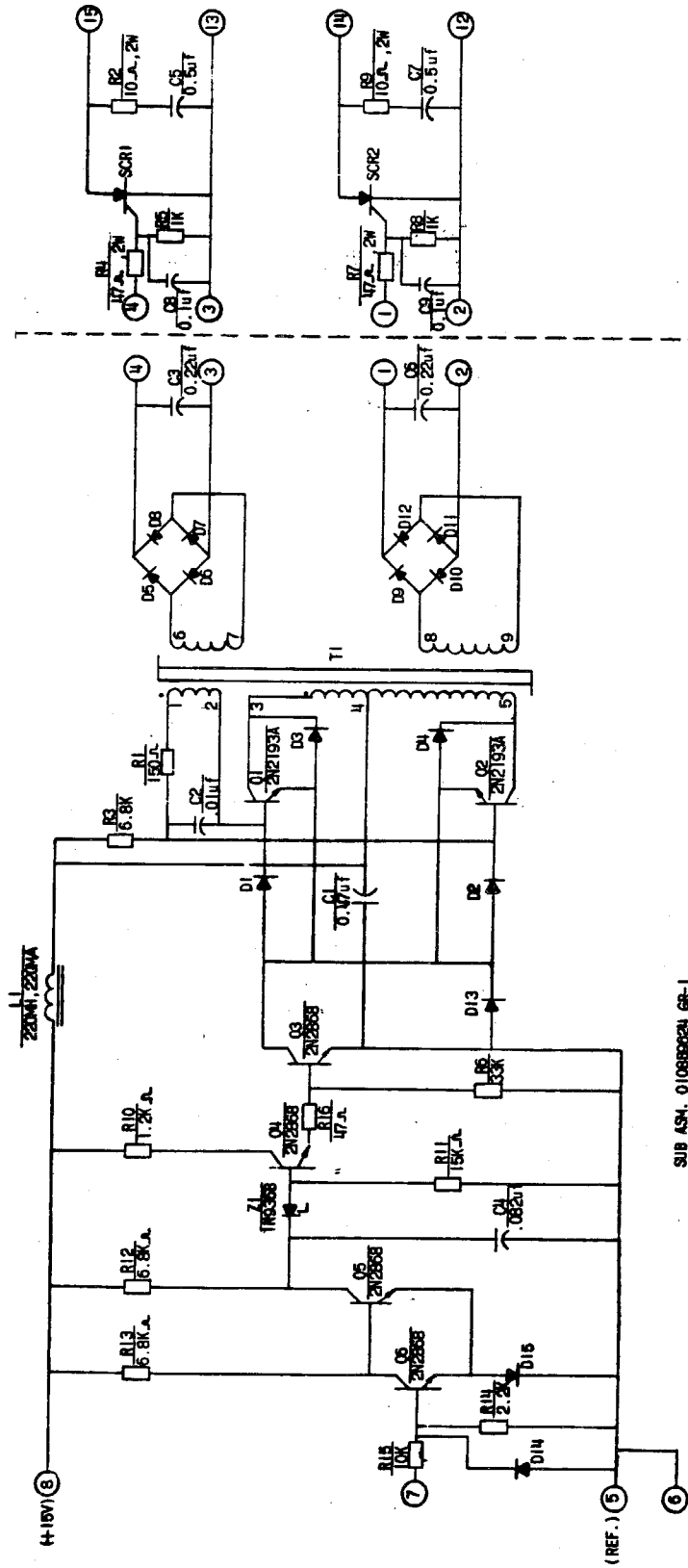

Figure 3 (0285A6644-0) Component Location Diagram for the Type SLAT53K Relay



ALL DIODES IN4148 UNLESS NOTED
 ALL RES. 1/2 WATT ± 5% UNLESS NOTED
 (2) = TERM. POST ON BOARD ASM
 IN9358 - 9.1V ± 1%

SUB ASM. 0108B9624 GR-1

Figure 4 (0108B9610-0) Internal Connections for the SCR Trip and Isolation Subassemblies

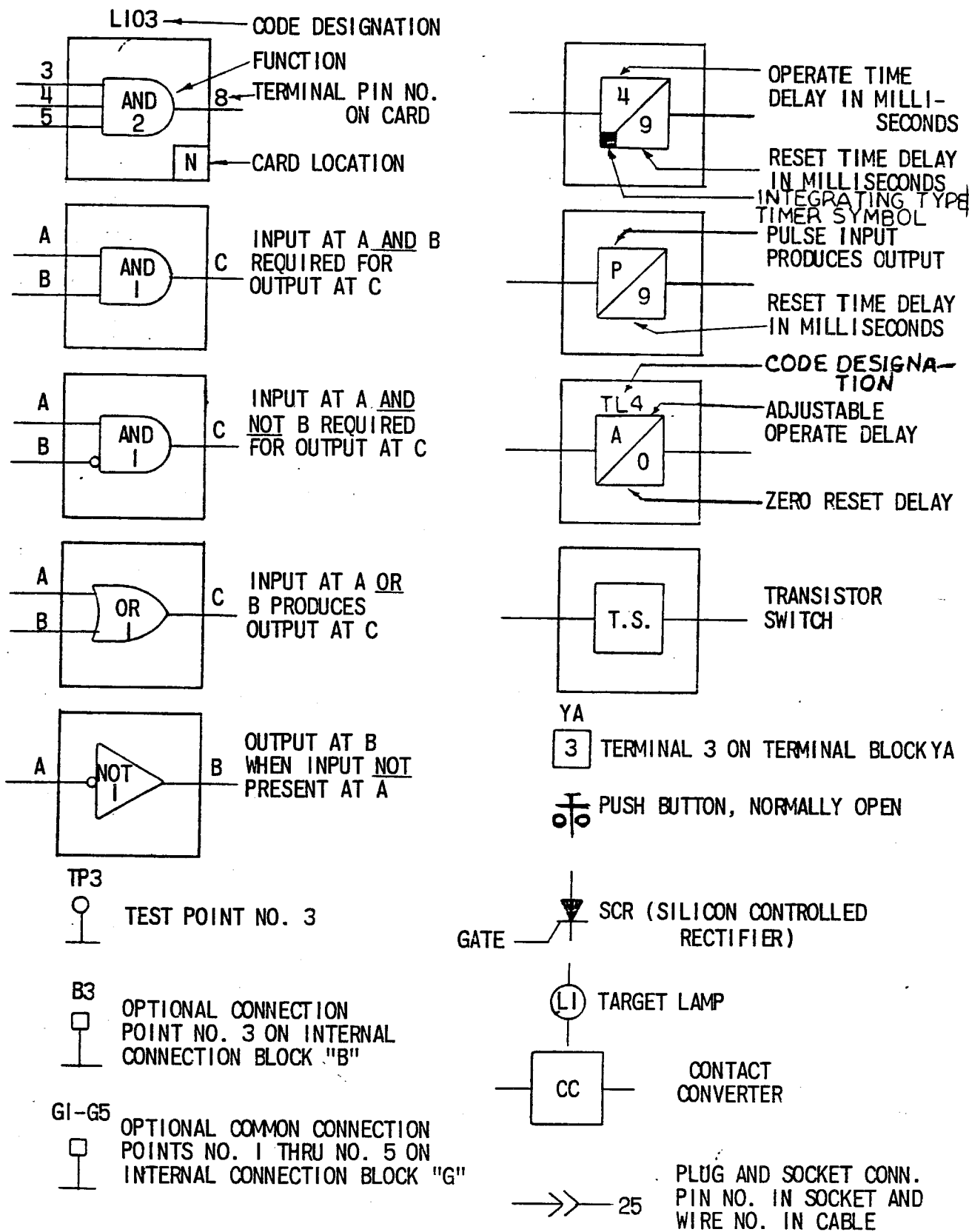
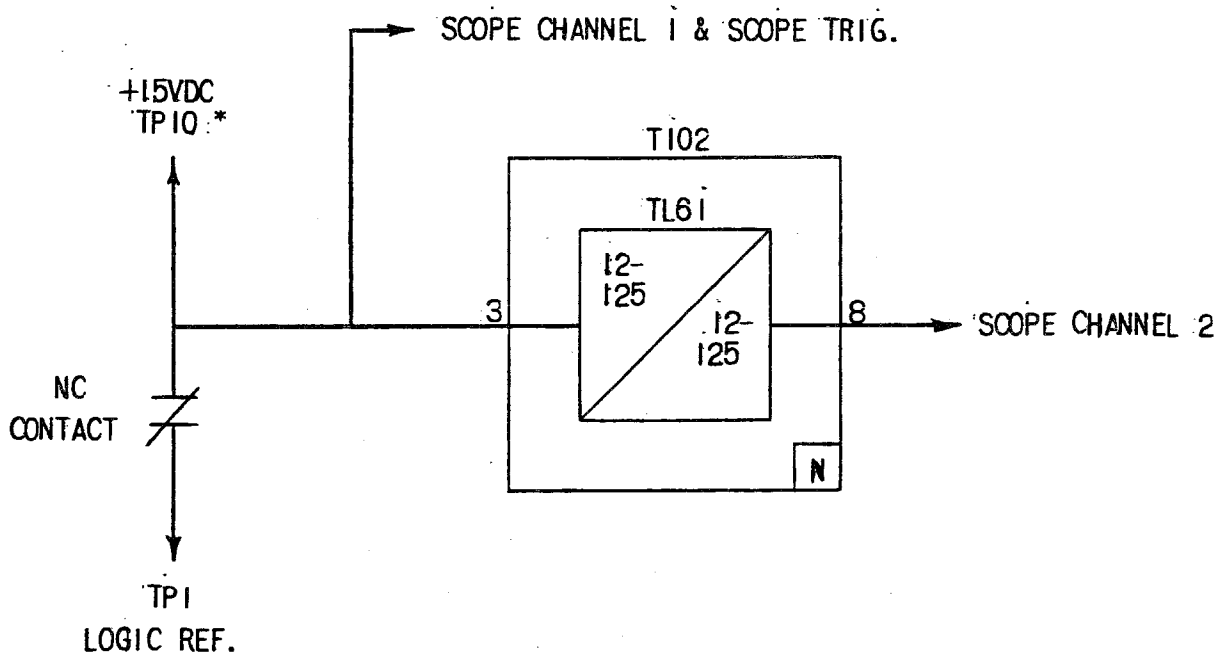

Figure 5 (0227A2047-1) Internal Connection Diagram Legend



* THE 15VDC SIGNAL AT PIN 10 HAS A CURRENT LIMITING RESISTOR MOUNTED ON THE TEST CARD.

Figure 6 (0246A7987-0) Logic Timer Test Circuit

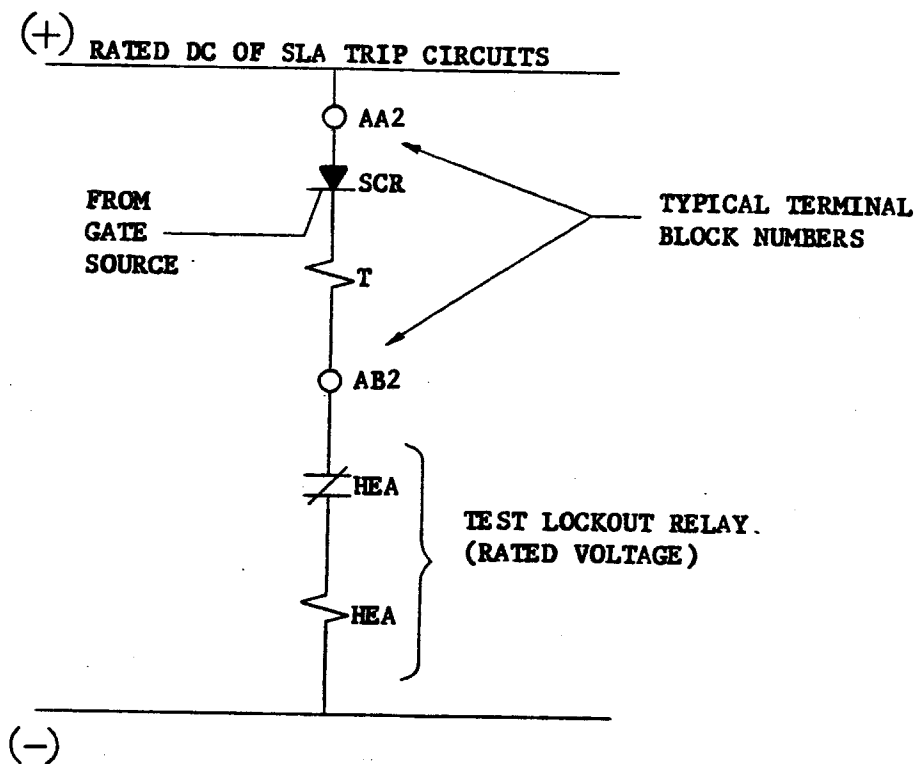

Figure 7 (0208A2365-0) Typical SCR Trip Circuit Test Connections