



**INSTRUCTIONS**

**GEK-86080**

**STATIC OUTPUT AND TRIPPING RELAY**

**TYPE SLAT53L**

---

**GENERAL  ELECTRIC**

CONTENTS

	<u>PAGE</u>
<b>DESCRIPTION</b> .....	3
<b>APPLICATION</b> .....	3
<b>RATINGS</b> .....	3
<b>BURDENS</b> .....	4
<b>FUNCTIONS</b> .....	4
SCR TRIP CIRCUITS (TA, TB, TC) .....	4
TELEPHONE RELAY CIRCUITS .....	4
AUXILIARY REED RELAY OUTPUTS .....	4
BFI BREAKER FAILURE INITIATE CIRCUIT .....	4
CONTACT CONVERTERS - CC31 AND CC31A .....	5
TARGETS .....	5
<b>LOGIC CIRCUITS</b> .....	5
<b>CONSTRUCTION</b> .....	5
<b>RECEIVING, HANDLING AND STORAGE</b> .....	6
<b>INSTALLATION TESTS</b> .....	6
CAUTION .....	6
GENERAL .....	6
OPERATIONAL CHECKS .....	7
TEST CARD ADAPTER .....	7
TRIP CIRCUIT TESTS .....	7
OVERALL EQUIPMENT TESTS .....	7
<b>MAINTENANCE</b> .....	8
PERIODIC TESTS .....	8
TROUBLESHOOTING .....	8
SPARE PARTS .....	8

## STATIC OUTPUT AND TRIPPING RELAY

### TYPE SLAT53L

#### DESCRIPTION

The Type SLAT53L relay is a rack mounted output and tripping unit containing both electromechanical relays, SCR tripping circuits and solid state circuitry. The SLAT53L provides the output circuits for a single pole tripping and reclosing scheme. Other solid state relays, a power supply, and a test panel are required for a complete protective system.

#### APPLICATION

Refer to the overall logic diagram and its associated logic description for specific information regarding the particular scheme in which this relay is employed.

#### RATINGS

The Type SLAT53L relay is designed for use in an environment where the ambient temperature around the relay case is between minus 20°C and plus 65°C.

The Type SLAT53L relay requires a plus and minus 15 VDC power source with zero volts DC reference, which can be obtained from a Type SSA power supply.

The tripping circuits are rated for 48/125 or 250 VDC. Each has a 1.0 ampere series target. The tripping circuits are designed to carry 30 amperes for one second.

The contacts of the telephone-type relays that are used for TR32, TR33 and TR37 will make and carry three amperes continuously and will interrupt up to 180 volt-amperes resistive (60 volt-amperes inductive).

The contacts of the reed relays RR35, RR36, RR42 and BFI will make and carry three amperes for tripping duty and are continuously rated for three amperes. The contacts will interrupt up to 100 volt-amperes resistive (35 volt-amperes inductive).

The contacts of reed relays RR31 and RR34 will make and carry 0.5 ampere. The contacts will interrupt ten volt-amperes resistive.

Contact converters CC31 and CC31A have a link for selecting the proper voltage for the coil circuit of the converter. The available taps are for 48, 125 and 250 VDC.

*These instructions do not purport to cover all details or variations in equipment nor to provide for every possible contingency to be met in connection with installation, operation or maintenance. Should further information be desired or should particular problems arise which are not covered sufficiently for the purchaser's purposes, the matter should be referred to the General Electric Company.*

*To the extent required the products described herein meet applicable ANSI, IEEE and NEMA standards; but no such assurance is given with respect to local codes and ordinances because they vary greatly.*

## BURDENS

The SLAT53L relay presents a maximum burden to the Type SSA power supply of:

200 milliamperes from the +15 VDC supply  
200 milliamperes from the -15 VDC supply

The contact converters, when energized, draw ten milliamperes each from the station battery.

Each target lamp draws 80 milliamperes from the minus 15 volt DC supply.

## FUNCTIONS

Not all of these functions will be supplied on every unit. Refer to the unit nameplate or associated overall logic diagram for the included functions.

### SCR TRIP CIRCUITS(TA, TB, TC)

Electrically separate, isolated SCR trip circuits are provided. Each circuit is capable of carrying 30 amperes for one second.

The internal connections for the SCR trip and isolator subassemblies are shown in Figure 6. The isolator card, by means of a DC-to-DC converter, provides a signal path but maintains metallic isolation. This feature makes it possible to isolate the relay power supply from the trip circuit power supply.

### TELEPHONE RELAY CIRCUITS

Two electrically separate, normally open contacts are provided per telephone relay circuit (TR32, TR33 and TR37). These contacts close within 17 milliseconds from the time the relay coil is energized by the logic. The contacts open within 170 milliseconds from the time the coil is de-energized. These functions use telephone-type relays with contact ratings as stated under **RATINGS**.

### AUXILIARY REED RELAY OUTPUTS

The usage of reed relays RR31, RR34, RR35, RR36 and RR42 is determined by the particular scheme in which the SLAT53L is employed. Each relay has two normally open contacts whose ratings are specified under **RATINGS**.

### BFI BREAKER FAILURE INITIATE CIRCUIT

Six electrically separate, normally open contacts are provided. These contacts close within two milliseconds from the time the associated coil is energized by the logic. These contacts open within two milliseconds from the time the coil is de-energized. The BFI function uses a reed relay with contact ratings stated under **RATINGS**.

CONTACT CONVERTERS - CC31 AND CC31A

When the contact associated with CC31 and CC31A is closed, all SCR trip circuit reed relays and telephone relays are prevented from operating. These contact converters are used to disable the relaying equipment.

TARGETS

Six electromechanical target coils are included, one in series with each tripping SCR. These targets operate on one ampere of trip current when the tripping circuit passes current. The target coil resistance is 0.40 ohm.

Nine target lamps are included in the SLAT53L. These are designated as indicated in the internal connections diagram (Figure 1).

**LOGIC CIRCUITS**

The functions of the Type SLAT53L relay involve basic logic (AND, OR, and NOT) where the presence or absence of signals, rather than their magnitude, controls the operation. Signals are measured with respect to a reference bus accessible at TP1. In general, a signal below one VDC represents an OFF or LOGIC ZERO condition; an ON or LOGIC ONE condition is represented by a signal of approximately plus 15 VDC.

The symbols used on the internal connection diagram (Figure 1) are explained by the legend shown in Figure 2.

**CONSTRUCTION**

The SLAT53L relay is packaged in an enclosed metal case with a hinged front cover and a removable top cover. The outline and mounting dimensions of the case and the physical location of the components are shown in Figure 4 and 5, respectively.

The SLAT53L relay contains printed circuit cards identified by a code number, such as A111, T102, L104; where A designates auxiliary function, T designates timer function, and L designates logic function. The printed circuit cards plug in from the front of the unit. The sockets are marked with letter designations or "addresses" (D, E, F, etc.) which appear on the guide strips in front of each socket, on the component location drawing, on the unit internal connection diagram, and on the printed circuit card. The test points (TP1, TP2, etc.) shown in the internal connection diagram are connected to instrument jacks on test cards in positions T and AT with TP1 at the top of the AT card. TP10 is tied to plus 15 VDC through a 1.5K resistor. This resistor limits the current when TP10 is used to supply a logic signal.

## RECEIVING, HANDLING AND STORAGE

These relays will normally be supplied as a part of a static relay equipment, mounted in a rack or cabinet with other static relays and test equipment. Immediately upon receipt of a static relay equipment, it should be unpacked and examined for any damage sustained in transit. If injury or damage resulting from rough handling is evident, file a damage claim at once with the transportation company and promptly notify the nearest General Electric Sales Office.

Reasonable care should be exercised in unpacking the equipment. If the equipment is not to be installed immediately, it should be stored indoors in a location that is free from moisture, dust, metallic chips, and severe atmospheric contaminants.

Just prior to final installation the shipping support bolt should be removed from each side of all relay units, to facilitate possible future unit removal for maintenance. These shipping support bolts are approximately eight inches back from the relay front panel. STATIC RELAY EQUIPMENT, WHEN SUPPLIED IN SWING RACK CABINETS, SHOULD BE SECURELY ANCHORED TO THE FLOOR OR TO THE SHIPPING PALLET TO PREVENT THE EQUIPMENT FROM TIPPING OVER WHEN THE SWING RACK IS OPENED.

## INSTALLATION TESTS

### CAUTION

THE LOGIC SYSTEM SIDE OF THE DC POWER SUPPLY USED WITH MOD III STATIC RELAY EQUIPMENT IS ISOLATED FROM GROUND. IT IS A DESIGN CHARACTERISTIC OF MOST ELECTRONIC INSTRUMENTS THAT ONE OF THE SIGNAL INPUT TERMINALS IS CONNECTED TO THE INSTRUMENT CHASSIS. IF THE INSTRUMENT USED TO TEST THE RELAY EQUIPMENT IS ISOLATED FROM GROUND, ITS CHASSIS MAY HAVE AN ELECTRICAL POTENTIAL WITH RESPECT TO GROUND. THE USE OF A TEST INSTRUMENT WITH A GROUNDED CHASSIS WILL NOT AFFECT THE TESTING OF THE EQUIPMENT. HOWEVER, A SECOND GROUND CONNECTION TO THE EQUIPMENT, SUCH AS A TEST LEAD INADVERTENTLY DROPPING AGAINST THE RELAY CASE, MAY CAUSE DAMAGE TO THE LOGIC CIRCUITRY. NO EXTERNAL TEST EQUIPMENT SHOULD BE LEFT CONNECTED TO THE STATIC RELAYS WHEN THEY ARE IN PROTECTIVE SERVICE, SINCE TEST EQUIPMENT GROUNDING REDUCES THE EFFECTIVENESS OF THE ISOLATION PROVIDED.

### GENERAL

If the SLAT53L relay that is to be tested is installed in an equipment which has already been connected to the power system, disconnect the outputs from the system before testing.

The SLAT53L relay is supplied from the factory either mounted in a static relay equipment or as a separate unit associated with measuring relays, a Type SSA power supply, and some form of channel equipment. All relay units for a given terminal of static relaying equipment are tested together at the factory, and each unit will have the same summary number stamped on its nameplate.

OPERATIONAL CHECKS

Operation of the SLAT53L unit can be checked by observing the signals at the twenty test points (TP1 to TP20) in the SLAT53L, or by observing the output functions. The test points are located on the test card in position T and AT and are numbered 1 to 20 from top to bottom. TP1 is the reference bus for the logic circuit; TP10 is plus 15 VDC. The remaining points are located at various strategic points throughout the logic as shown on the internal connection diagram (Figure 1). Test point voltages can be monitored with a portable high impedance voltmeter, the voltmeter on the test panel of the associated equipment, or an oscilloscope.

Operation of any logic function may be checked by supplying the correct inputs to the card. This is accomplished by placing the card under test in a card extender, removing the cards which normally supply the input signals, and then connecting the card inputs to either TP10 or TP1. An output should be produced when the proper combination of inputs is supplied to the card.

TEST CARD ADAPTER

The test card adapter provides a convenient means of gaining access to any pin of a particular card. Detailed information on the use of the test adapter card is included in the printed circuit card instruction book, GEK-34158.

TRIP CIRCUIT TESTS

The SCR trip circuits and the series mechanical targets may be checked by connecting an auxiliary lock-out relay, such as the Type HEA relay, in series with the SCR circuit. A typical circuit is shown in Figure 3. The HEA relay should have the same DC rating as the SCR trip circuit of the SLAT53L. If an auxiliary lock-out relay is not available, it can be replaced by a resistive load which limits the trip circuit current to three amperes.

Prior to final installation, a check of the overall trip circuit should be made with the SCR outputs connected to trip the circuit breakers.

OVERALL EQUIPMENT TESTS

After the SLAT53L relay and the associated static relay units have been individually calibrated and tested for the desired settings, a series of overall operating circuit checks is advisable.

The elementary, overall logic and logic description for the specific job will be useful for determining the overall operation of the scheme.

Overall equipment tests can be performed by applying alternating current and voltages to the measuring units as specified in the instruction book for the measuring units and checking that proper outputs are obtained.

## MAINTENANCE

### PERIODIC TESTS

It should be sufficient to check the outputs produced at test points in the SLAT53L when periodic calibration tests are made on the associated measuring units, for example, the phase and ground relays in a line-relaying scheme. No separate periodic tests on the SLAT53L itself should be required.

### TROUBLESHOOTING

In any troubleshooting of equipment, it should first be established which unit is functioning incorrectly. The overall logic diagram supplied with the equipment shows the combined logic of the complete equipment and the various test points in each unit. By signal tracing, using the overall logic diagram and the various test points, it should be possible to quickly isolate the trouble.

A test adapter card is supplied with each static relay equipment to supplement the prewired test points on the test cards. Use of the adapter card is described in the printed circuit card instruction book, GEK-34158.

A dual-trace oscilloscope is a valuable aid to detailed troubleshooting, since it can be used to determine phase shift, operate and reset times, as well as input and output levels. A portable dual-trace oscilloscope with a calibrated sweep and trigger facility is recommended.

### SPARE PARTS

To minimize possible outage time, it is recommended that a complete maintenance program should include the stocking of a least one spare card of each type. It is possible to replace damaged or defective components on the printed circuit cards, but great care should be taken in soldering so as not to damage or bridge-over the printed circuit buses, or overheat the semiconductor components. The repaired area should be recovered with a suitable high-dielectric plastic coating to prevent possible breakdowns across the printed buses due to moisture and dust. The wiring diagrams for the cards in the SLAT53L relay are included in the printed circuit card instruction book, GEK-34158.



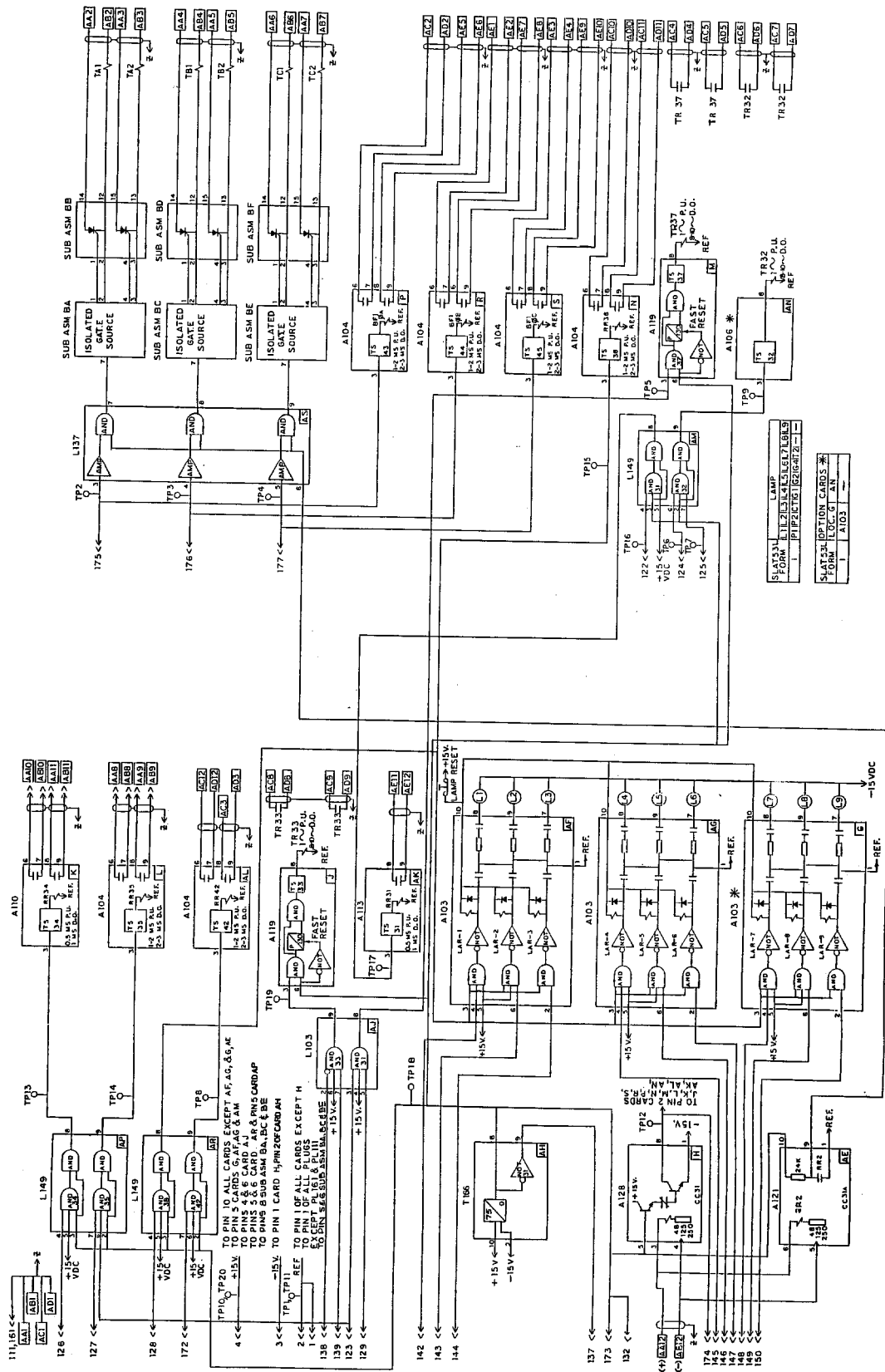

Figure 1 (0153D6032-0) Internal Connection Diagram for the SLAT53L Relay

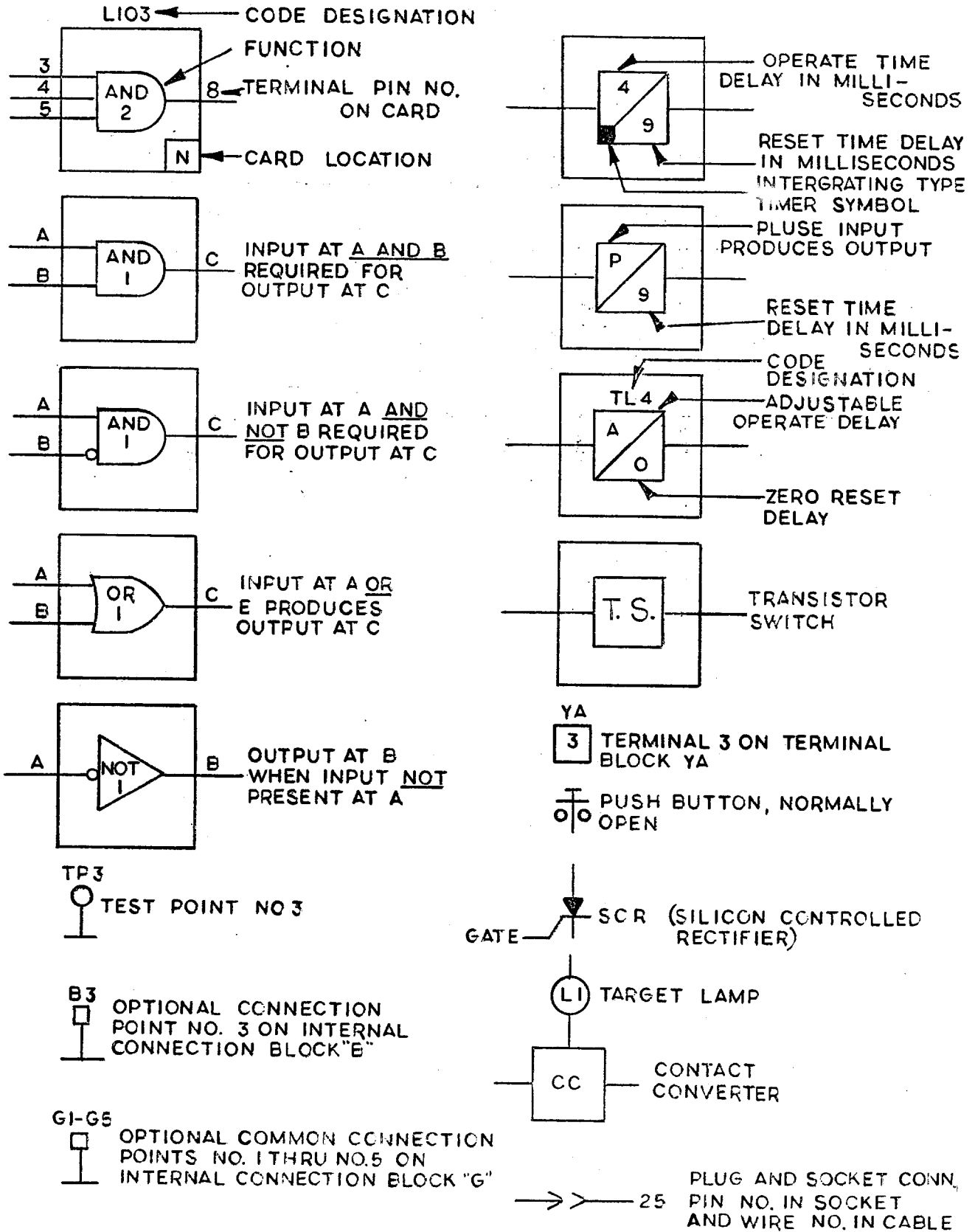

Figure 2 (0227A2047-1) Logic Legend for Internal Connection Diagram

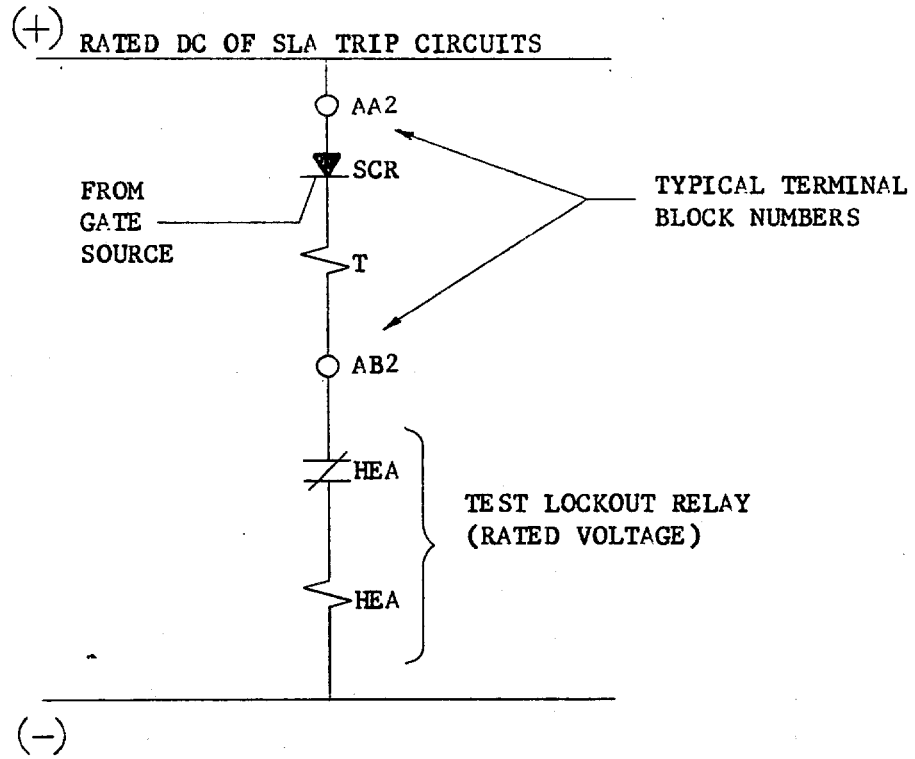

Figure 3 (0208A2365-0) Typical SCR Trip Circuit Test Connections

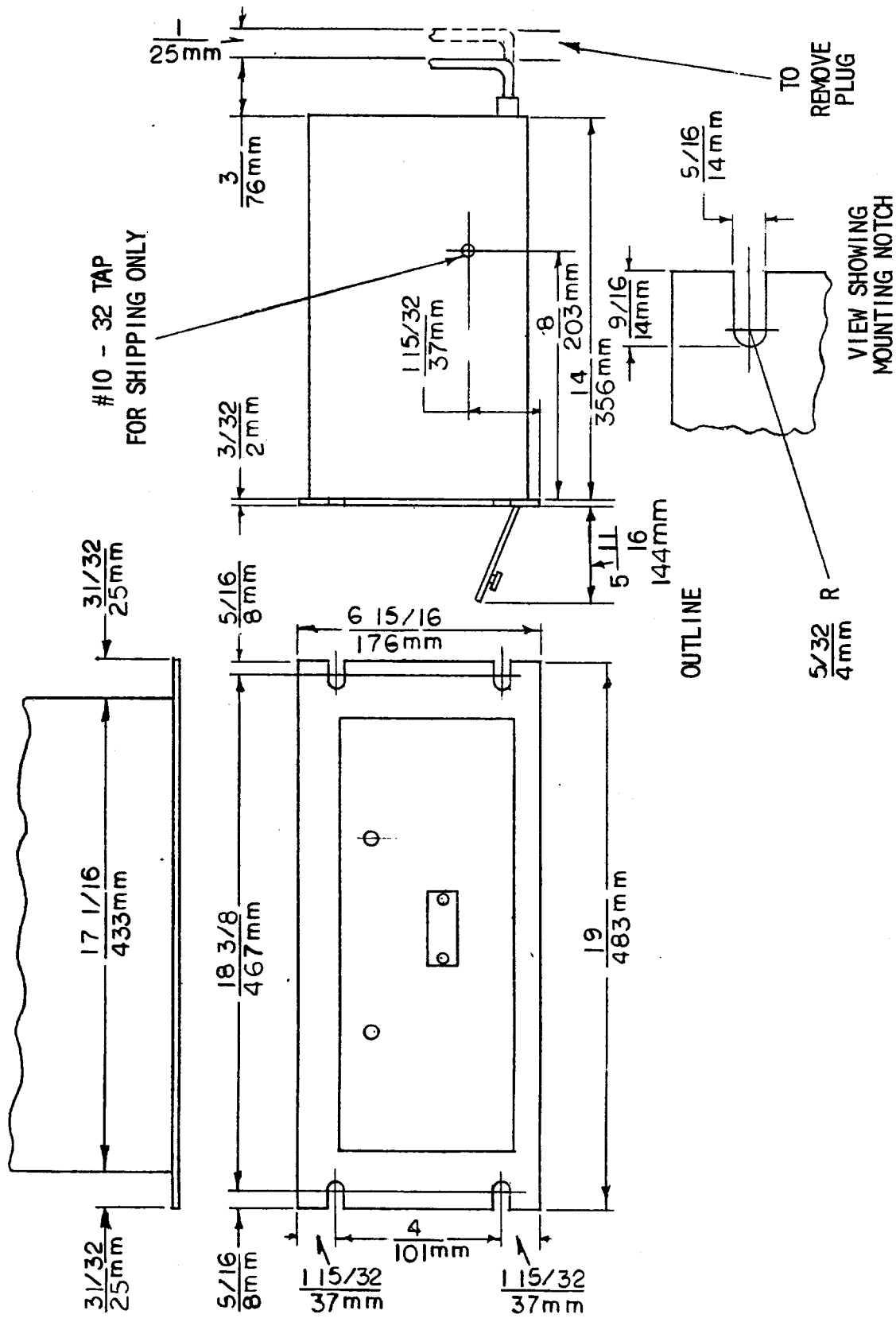
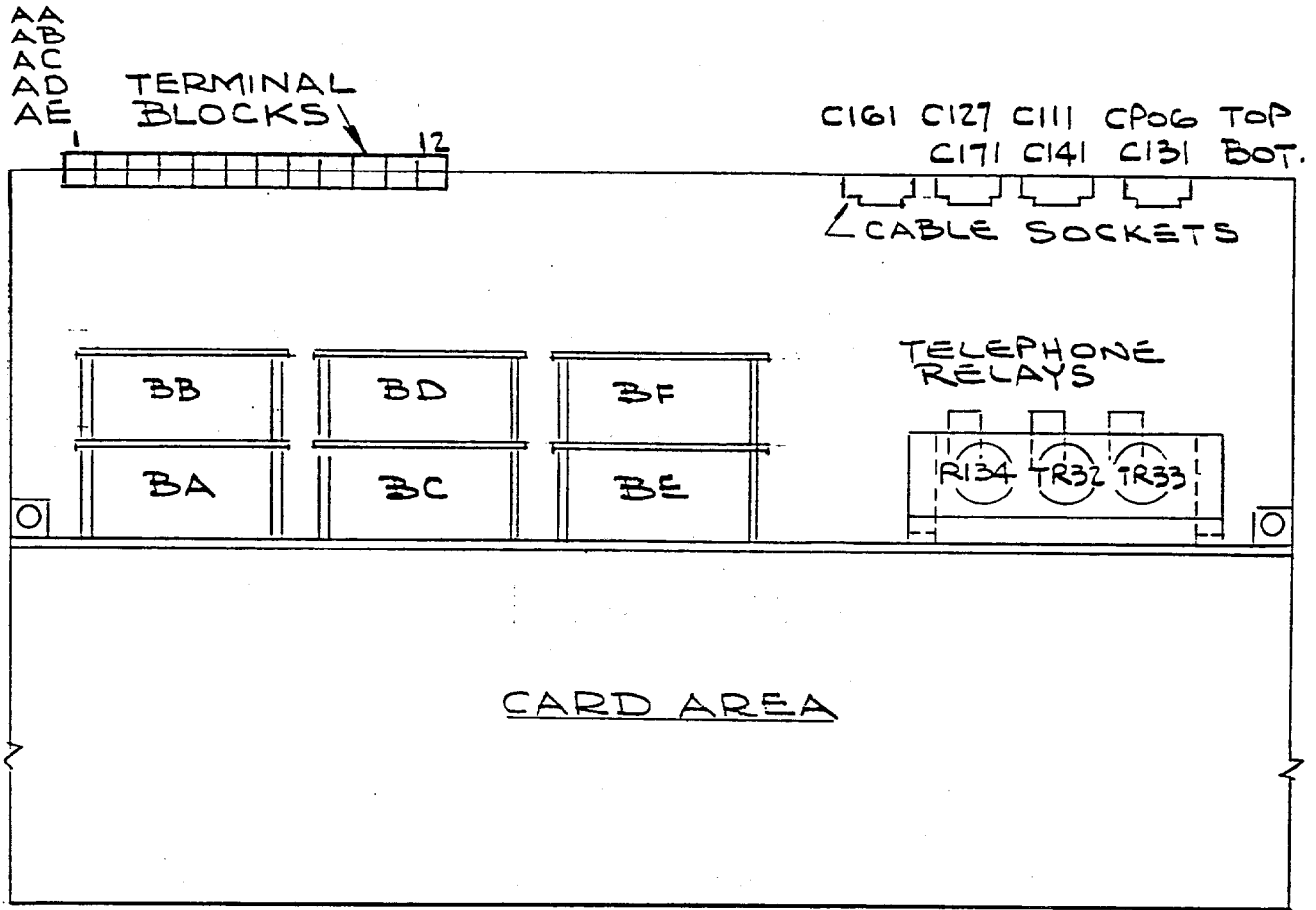

Figure 4 (0227A2037-0) Outline and Mounting Dimensions for the SLAT53L Relay



PLAN VIEW

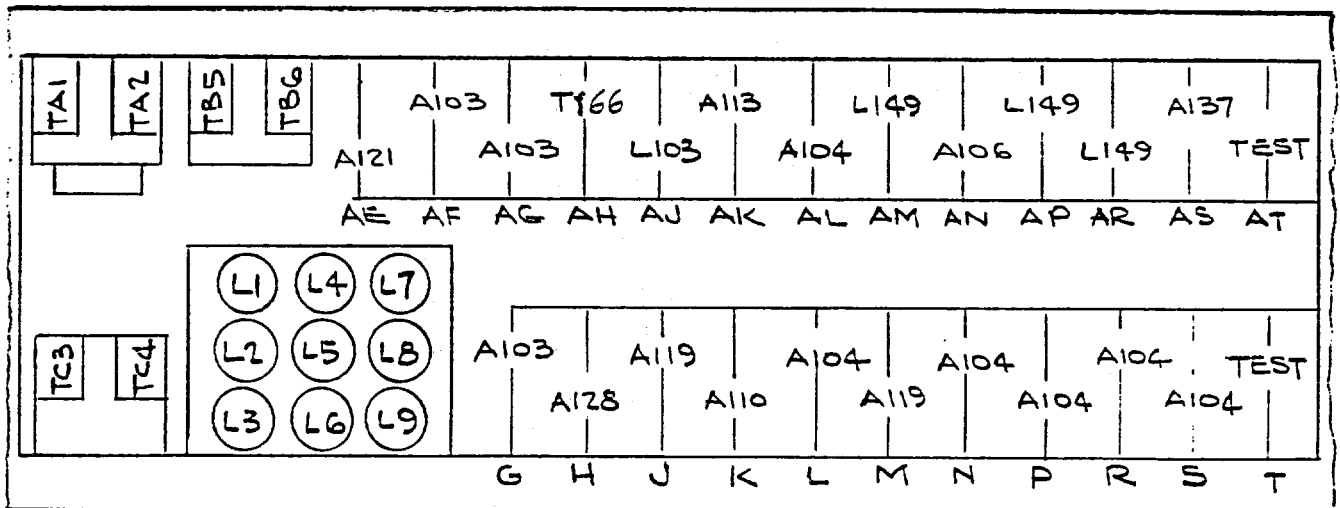
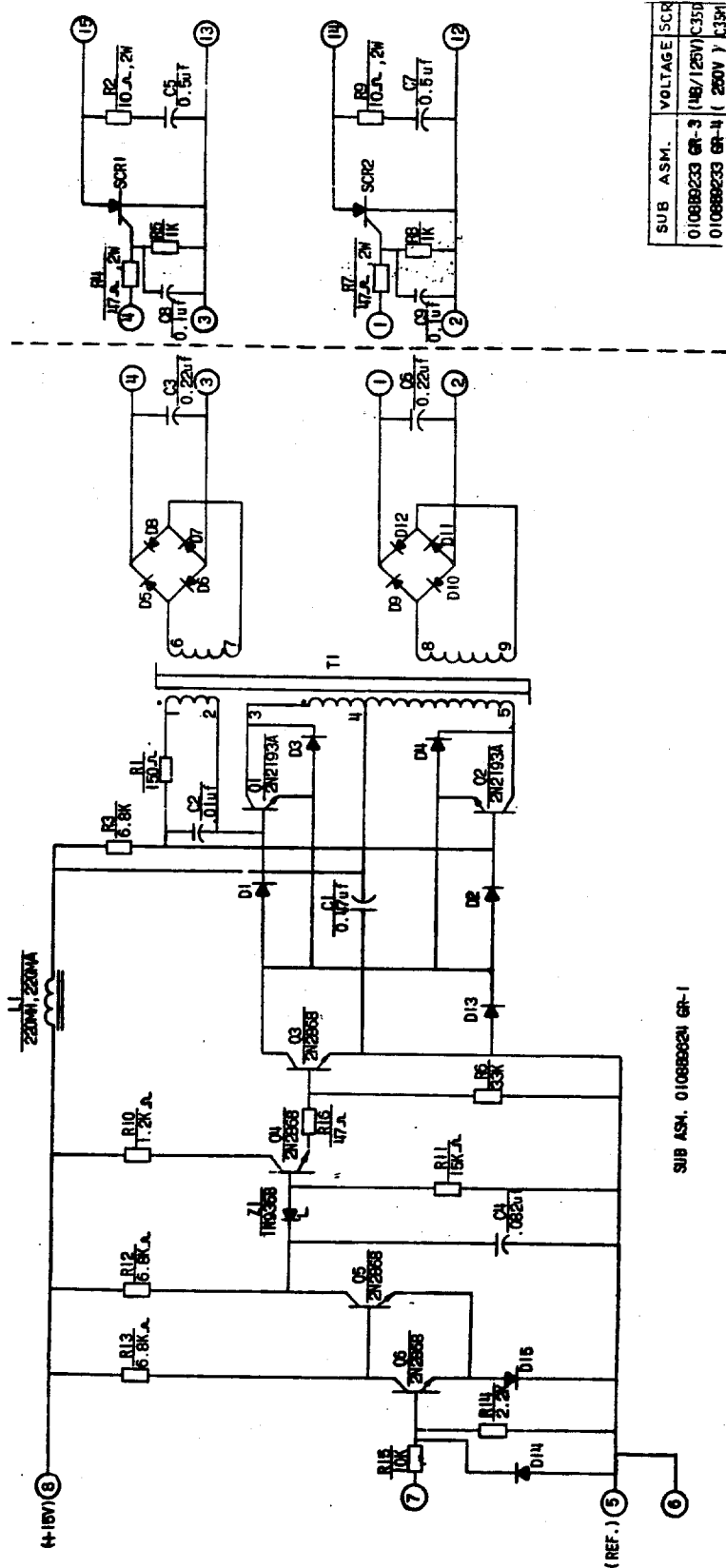

Figure 5 (0285A7045-0) Component Location Diagram for the SLAT53L Relay



SUB ASM.	VOLTAGE	SCR
0108B9233 GR-3	148/125V	K35F
0108B9233 GR-4	220V	K39H

ALL DIODES 1N4148 UNLESS NOTED  
 ALL RES. 1/2 WATT ± 5% UNLESS NOTED  
 (8) = TERM. POST ON BOARD ASM  
 1N9358 = 9.1V ± 5%

SUB ASM. 0108B9234 GR-1

Figure 6 (0108B9610-0) Internal Connections for the SCR Trip and Isolation Subassemblies

**GENERAL ELECTRIC COMPANY  
POWER SYSTEMS MANAGEMENT BUSINESS DEPT.  
MALVERN, PA 19355**

**GENERAL  ELECTRIC**