



INSTRUCTIONS

GEK-86671

**STATIC OUTPUT AND TRIPPING UNIT
TYPE SLAT54V**

GENERAL  ELECTRIC

CONTENTS

	<u>PAGE</u>
DESCRIPTION	3
APPLICATION	3
RATINGS	4
BURDENS	5
Trip Circuit.....	5
RI Reclose Initiate Circuit and V1 Positive Sequence Voltage Circuit	5
RC Reclose Cancel Circuit.....	6
TT and Key Transmitter Circuits.....	6
Optional Outputs.....	6
Contact Converters.....	6
TARGETS	6
LOGIC CIRCUITS	6
CALCULATION OF SETTINGS	6
CONSTRUCTION	7
RECEIVING, HANDLING AND STORAGE	7
TEST INSTRUCTIONS	8
Caution.....	8
General.....	8
Operational Checks.....	8
Test Card Adapter.....	9
Timer Adjustments and Tests.....	9
Trip Circuit Tests.....	9
Overall Equipment Tests.....	9
MAINTENANCE	10
Periodic Tests.....	10
Troubleshooting.....	10
Spare Parts.....	10

STATIC OUTPUT AND TRIPPING UNIT TYPE SLAT54V

DESCRIPTION

The Type SLAT54V relay is a static output and tripping unit. The relay is not intended to be used by itself, but rather as part of a complement of equipment that forms a protective relaying scheme. For a complete description of the overall scheme in which this relay is employed, refer to the overall logic diagram and its associated logic description that is supplied with each terminal of equipment.

The SLAT54V relay is packaged in a four-rack-unit (one rack unit equals 1-3/4 inches) enclosed in a metal case suitable for mounting in a 19-inch rack. The outline and mounting dimensions are shown in Fig. 1. The internal connections for the relay are shown in Fig. 2. The component and card locations are shown in Fig. 3.

APPLICATION

The SLAT54V relay is a static output and tripping relay that was designed for use in a variety of schemes. For example, the SLAT54V can be used with Types SLYP, SLCN, SLS, SLAT (single pole), SSA and SLA relays to make up a three pole or single pole tripping directional comparison scheme. For a complete description of the application of this relay in a particular scheme, refer to the logic description and diagram supplied with the scheme. The following is a list of the various functions included in the relay.

- TR - The tripping circuit includes a single relay with two separate normally-open contacts which are in series with mechanical target coils.
- RI - The reclose initiation outputs are provided to initiate automatic reclosing after a high speed trip.
- T1, T2 - Electromechanical targets that give an indication when the associated contact passes trip current.
- TT - Transfer trip outputs are provided to signal the remote terminal to trip when local three-phase trip is initiated.
- RC - Reclose cancel outputs are provided to prevent reclosing when faults occur during line pickup operation or when a Zone Two trip occurs.
- V1 - Positive sequence voltage outputs are provided to indicate presence of a certain preset level of positive sequence voltage at the local terminal.

These instructions do not purport to cover all details or variations in equipment nor to provide for every possible contingency to be met in connection with installation, operation or maintenance. Should further information be desired or should particular problems arise which are not covered sufficiently for the purchaser's purposes, the matter should be referred to the General Electric Company.

To the extent required the products described herein meet applicable ANSI, IEEE and NEMA standards; but no such assurance is given with respect to local codes and ordinances because they vary greatly.

KEY XMTR - Key transmitter outputs are provided to key, via contacts, associated channel transmitter. KEY XMTR is controlled by logic signals in the associated SLA relay.

CONTACT CONVERTERS - The CC4/CC31 contact converter is supplied to allow for remote reset of target contacts. The CC5/CC32 contact converter is supplied to allow for disabling of all output contacts.

OPTIONAL - Two optional outputs, each having one normally-open contact, are available.

TARGET CONTACTS - Provide an output to indicate the function that initiated tripping.

RATINGS

The Type SLAT54V relay is designed for use in an environment where the air temperature outside the relay case does not exceed - 20°C and + 65°C.

The Type SLAT54V relay requires a ± 15 VDC power source which can be obtained from a Type SSA power supply.

The tripping circuits are available in ratings for 48, 125 or 250 VDC.

The contacts of the telephone-type relays that are used for TR will make and carry 3 amperes continuously, and will interrupt up to 0.5 ampere (inductive) at 125 VDC.

The ratings for the RI and VI relays are listed in Table I, the ratings of the RC are listed in Table II, and the ratings of the TT, AUX STOP, KEY XMTR, and optional outputs are listed in Table III.

Refer to unit nameplate for the ratings of a particular relay.

TABLE I

ABSOLUTE MAXIMUM RATINGS, RI & VI	
180 VA Resistive	} Interruption Capacity
60 VA Inductive**	
3 Amperes make and carry continuous	
30 Amperes make and carry short time	

TABLE II

ABSOLUTE MAXIMUM RATINGS, RC	
100 VA Resistive	} Interruption Capacity
35 VA Inductive**	
3 Amperes make and carry continuous	
3 Amperes make and carry short time	

TABLE III

ABSOLUTE MAXIMUM RATINGS TT, AUX STOP, KEY XMTR	
10 VA Resistive	} Interruption Capacity
3 VA Inductive**	
0.5 Ampere make and carry continuous	
0.5 Ampere make and carry short time	

**The inductive rating is based on the inductance of a coil having a X_L/R ratio of three-to-one.

BURDENS

The SLAT54V relay presents a maximum burden to the Type SSA power supply of:

- 200 milliamperes from the +15 VDC supply
- 130 milliamperes from the -15 VDC supply

TRIP CIRCUIT

There are two electrically separate, normally-open trip circuits. In addition there is an electromechanical target which indicates trip current was passed by the associated trip contact. The contact outputs permit isolating the relay power supply from the trip circuit power supply.

RI RECLOSE INITIATE CIRCUIT AND V1 POSITIVE SEQUENCE VOLTAGE CIRCUIT

For V1, two electrically separate normally-open and one normally-closed contact are provided. For RI, two electrically separate normally-open contacts are provided. These contacts close within 16 milliseconds from the time the associated coil is energized by the logic. The contacts open within 160 milliseconds from the time the coil is deenergized. The RI function uses a telephone-type relay with contact ratings stated under **RATINGS**.

RC RECLOSE CANCEL CIRCUIT

Two electrically separate normally-open contacts are provided. These contacts close within 2 milliseconds from the time the associated coil is energized by the logic. These contacts open within 3 milliseconds from the time the coil is deenergized.

TT, KEY XMTR CIRCUITS

Each consists of two electrically separate normally-open contacts. These contacts close within 0.5 millisecond from the time the associated coil is energized by the logic. These contacts open within 0.5 millisecond from the time the coil is deenergized. These contacts use reed relays with contact ratings stated under RATINGS.

OPTIONAL OUTPUTS

Six optional reed relay contact outputs can be provided in either normally-open or normally-closed configuration. The contacts operate within 0.5 millisecond from the time logic signals (available from the selected matrix points in the associated SLA) change state.

CONTACT CONVERTERS

Two contact converters are included, each of which can be picked up from 48, 125 or 250 VDC sources.

TARGETS

Two electromechanical target coils are included; one in series with each output contact. These contacts operate on 1 ampere of trip current. The trip circuit resistance in the relay is 0.35 ohm. Six target output contacts are included in the Type SLAT54V as shown on the internal connections diagram, Fig. 2. For the target contact outputs provided, refer to the overall logic diagram for the scheme.

LOGIC CIRCUITS

The functions of the Type SLAT54V involve basic logic (AND, OR, and NOT) where the presence or absence of signals, rather than their magnitude, controls the operation. Signals are measured with respect to a reference bus accessible at TP1. In general, a signal below 1 VDC represents an OFF or LOGIC ZERO condition; an ON or LOGIC ONE is represented by a signal of approximately + 15 VDC.

The symbols used on the internal connection diagram (Fig. 2) are explained by the legend shown in Fig. 5.

CALCULATION OF SETTINGS

The SLAT54V is an integral part of an overall scheme, and reference should be made to the overall logic diagram description for both application and setting information.

CONSTRUCTION

The SLAT54V relay is packaged in an enclosed metal case with hinged front cover and removable top cover. The outline and mounting dimensions of the case and the physical location of the components are shown in Fig. 1 and 3, respectively.

The SLAT54V relay contains printed circuit cards identified by a code number such as: A104, T115, L109 where A designates an auxiliary function, T designates a time-delay function, and L designates a logic function. The printed circuit cards plug in from the front of the unit. The sockets are marked with letter designations or "addresses" (D, E, F, etc.), which appear on the guide strips in front of each socket, on the component location drawings, on the unit internal connection diagram, and on the printed circuit card. The test points (TP1, TP2, etc.) shown on the internal connections diagram are connected to instrument jacks on the test card in position T with TP1 at the top of the AT card. TP1 is tied to reference; TP10 is tied to + 15 VDC through a 2.2K resistor. The resistor limits the current when TP10 is used to supply a logic signal to a card.

The SLAT54V relay receives its inputs from the associated Type SLA relay. These units are interconnected by 10-conductor shielded cables. The sockets for these cables are located on the rear panel of the unit. The SLAT54V output functions are connected to 12-point terminal strips, which are also located on the rear of the unit.

A window is provided in the hinged cover of the relay to allow the mechanical targets to be seen. Push buttons are also provided to reset the targets without opening the cover.

RECEIVING, HANDLING AND STORAGE

The SLAT54V relay will normally be supplied as part of a static relay equipment, mounted in a rack or cabinet with other static relays and test equipment. Immediately upon receipt of a static relay equipment, it should be unpacked and examined for any damage sustained in transit. If injury or damage resulting from rough handling is evident, file a damage claim at once with the transportation company and promptly notify the nearest General Electric Sales Office.

Reasonable care should be exercised in unpacking the equipment. If the equipment is not to be installed immediately, it should be stored indoors in a location that is free from moisture, dust, metallic chips, and severe atmospheric contaminants.

Just prior to final installation, the shipping support bolt should be removed from each side of all relay units, to facilitate possible future unit removal for maintenance. These shipping support bolts are approximately eight inches back from the relay front panel.

STATIC RELAY EQUIPMENT, WHEN SUPPLIED IN SWING RACK CABINETS, SHOULD BE SECURELY ANCHORED TO THE FLOOR OR TO THE SHIPPING PALLET TO PREVENT THE EQUIPMENT FROM TIPPING OVER WHEN THE SWING RACK IS OPENED.

TEST INSTRUCTIONS

CAUTION:

THE LOGIC SYSTEM SIDE OF THE DC POWER SUPPLY USED WITH MOD III STATIC RELAY EQUIPMENT IS ISOLATED FROM GROUND. IT IS A DESIGN CHARACTERISTIC OF MOST ELECTRONIC INSTRUMENTS THAT ONE OF THE SIGNAL INPUT TERMINALS IS CONNECTED TO THE INSTRUMENT CHASSIS. IF THE INSTRUMENT USED TO TEST THE RELAY EQUIPMENT IS ISOLATED FROM GROUND, ITS CHASSIS MAY HAVE AN ELECTRICAL POTENTIAL WITH RESPECT TO GROUND. THE USE OF A TEST INSTRUMENT WITH A GROUNDED CHASSIS WILL NOT AFFECT THE TESTING OF THE EQUIPMENT. HOWEVER, A SECOND GROUND CONNECTION TO THE EQUIPMENT, SUCH AS A TEST LEAD INADVERTENTLY DROPPING AGAINST THE RELAY CASE, MAY CAUSE DAMAGE TO THE LOGIC CIRCUITRY. NO EXTERNAL TEST EQUIPMENT SHOULD BE LEFT CONNECTED TO THE STATIC RELAYS WHEN THEY ARE IN PROTECTIVE SERVICE, SINCE TEST EQUIPMENT GROUNDING REDUCES THE EFFECTIVENESS OF THE ISOLATION PROVIDED.

IF THE SLAT54V RELAY THAT IS TO BE TESTED IS INSTALLED IN AN EQUIPMENT WHICH HAS ALREADY BEEN CONNECTED TO THE POWER SYSTEM, DISCONNECT THE OUTPUTS TO THE SYSTEM DURING TEST.

GENERAL

The SLAT54V relay is supplied from the factory either as a separate unit, or mounted in a static relay equipment associated with measuring relays, a Type SSA power supply, and some form of channel equipment. All relay units for a given terminal of static relaying equipment are tested together at the factory, and each unit will have the same summary number stamped on its nameplate.

In general, when a time range is indicated on the internal connections diagram, the timer has been factory set at a mid-range value. Timers should be set for the operating or reset times indicated on the associated overall logic diagram. Where a time range is indicated on the overall logic diagram, the timer should be set for the value recommended for that function in the descriptive writeup accompanying the overall logic diagram. Where a setting depends upon conditions encountered on a specific application, this is so stated and the factors influencing the choice of setting are described. The procedure for checking and setting the timers is described in a later section.

OPERATIONAL CHECKS

Operation of the SLAT54V unit can be checked by observing the signals at the twenty test points (TP1 to TP20) in the SLAT54V, by observing the operation of the associated channel equipment, or by observing the output functions. The test points are located on the test cards in positions T and AT and are numbered 1 to 20 from top to bottom. TP1 is the reference bus for the logic circuit, TP10 is at + 15 VDC. The remaining points are located at various strategic points throughout the logic as shown in the internal connection diagram (Fig. 2). Test point voltages can be monitored with a portable high impedance voltmeter, the voltmeter on the test panel of the associated equipment, or an oscilloscope.

TEST CARD ADAPTER

The test card adapter provides a convenient means of gaining access to any pin of a particular card. Detailed information on the use of the test adapter card is included in the card instruction book, GEK-34158.

TIMER ADJUSTMENTS AND TESTS

When the time-delay cards are to be adjusted or checked, an oscilloscope that can display two traces simultaneously, and that has a calibrated horizontal sweep, should be used.

In order to test the timer cards, it is necessary to remove the card previous to the timer and to place the timer card in a card adapter. The card adapter allows access to the input and output of the timer if they are not brought out on test points. The timer test circuit is shown on Fig. 6. Opening the normally-closed contact causes the output to step up to + 15 VDC after the pickup delay of the timer. To increase the pickup time, turn the upper potentiometer on the timer card clockwise; to decrease the time, turn it counterclockwise. Closing the contact causes the timer output to drop out after the reset time-delay setting of the card. If the timer card is provided with a variable reset delay, it can be adjusted by the lower potentiometer on the timer card (clockwise increases reset time).

TRIP CIRCUIT TESTS

The trip circuits and series mechanical targets may be checked by connecting an auxiliary lock-out relay, such as the Type HEA relay, in series with the trip circuit. A typical circuit is shown in Fig. 4. The HEA relay should have the same DC rating as the trip circuit of the relay. If an auxiliary lock-out relay is not available, it can be replaced by a resistive load which limits the trip circuit current to 3 amperes. In most equipments, the trip circuit can be energized by operating a test push button.

OVERALL EQUIPMENT TESTS

After the SLAT54V relay and the associated static relay units have been individually calibrated and tested for the desired settings, a series of overall operating circuit checks is advisable.

The elementary, overall logic, and logic description for the specific job will be useful for determining the overall operation of the scheme.

An overall equipment test can be performed by applying the AC current and voltages to the measuring units, as specified in the instruction book for the measuring units, and checking that proper outputs are obtained when the measuring units operate.

MAINTENANCE

PERIODIC TESTS

It should be sufficient to check the outputs produced at test points in the SLAT54V when periodic calibration tests are made on the associated measuring units, for example, the phase and ground relays in a line relaying scheme. No separate periodic tests on the SLAT54V itself should be required.

TROUBLESHOOTING

In any troubleshooting of equipment, it should first be established which unit is functioning incorrectly. The overall logic diagram supplied with the equipment shows the combined logic of the complete equipment and the various test points in each unit. By signal tracing, using the overall logic diagram and the various test points, it should be possible to isolate the trouble quickly.

A test adapter card is supplied with each static relay equipment to supplement the prewired test points on the test cards. Use of the adapter card is described in the card instruction book GEK-34158.

A dual trace oscilloscope is a valuable aid to detailed troubleshooting, since it can be used to determine phase shift, operate and reset times, as well as input and output levels. A portable dual-trace oscilloscope with a calibrated sweep and trigger facility is recommended.

SPARE PARTS

To minimize possible outage time, it is recommended that a complete maintenance program should include the stocking of at least one spare card of each type. It is possible to replace damaged or defective components on the printed circuit cards, but great care should be taken in soldering, so as not to damage or bridge-over the printed circuit buses, or overheat the semiconductor components. The repaired areas should be re-covered with a suitable hi-dielectric plastic coating to prevent possible breakdowns across the printed buses due to moisture and dust. The wiring diagrams for the cards in the SLAT54V relay are included in the card book GEK-34158.

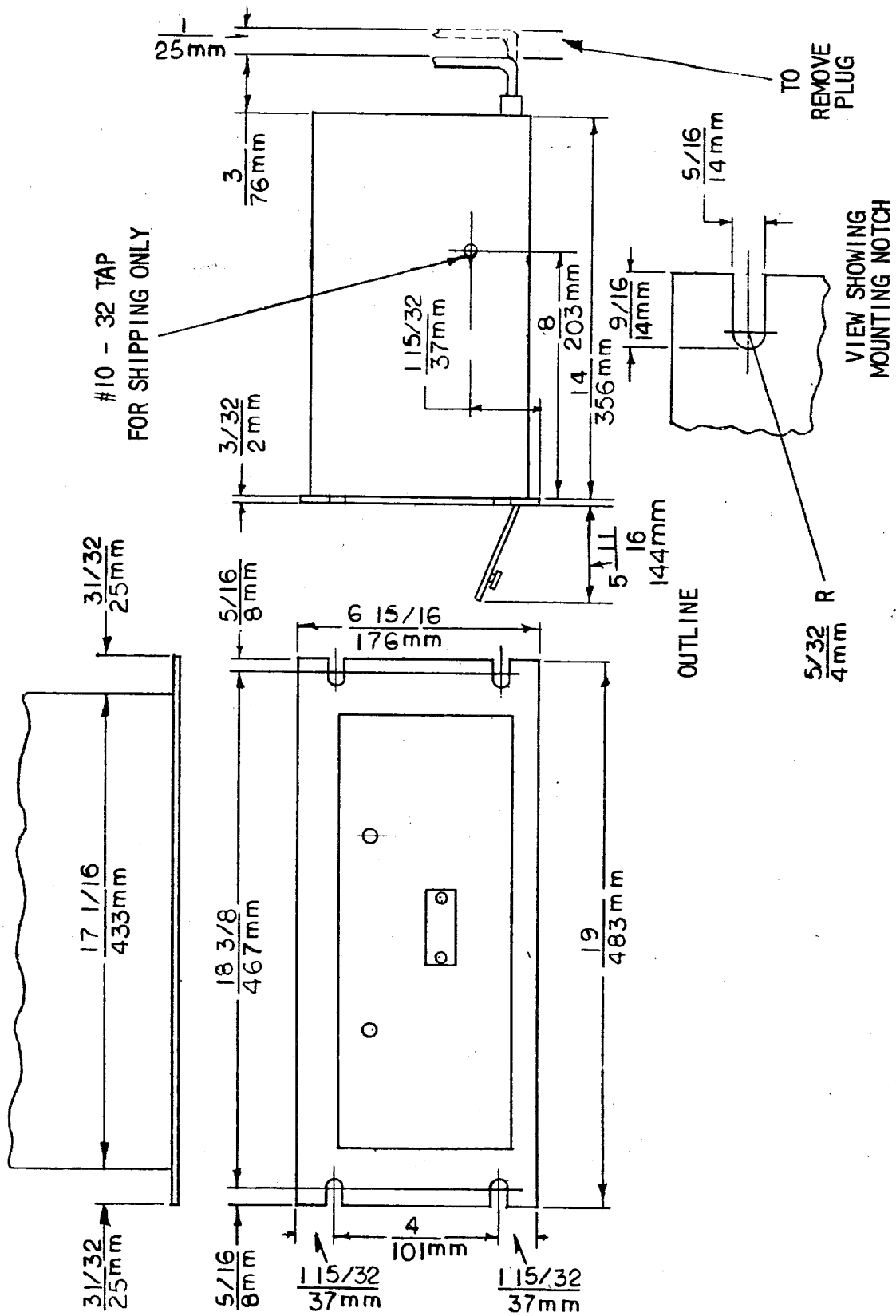

Fig. 1 (0227A2037-0) Outline and Mounting Dimensions

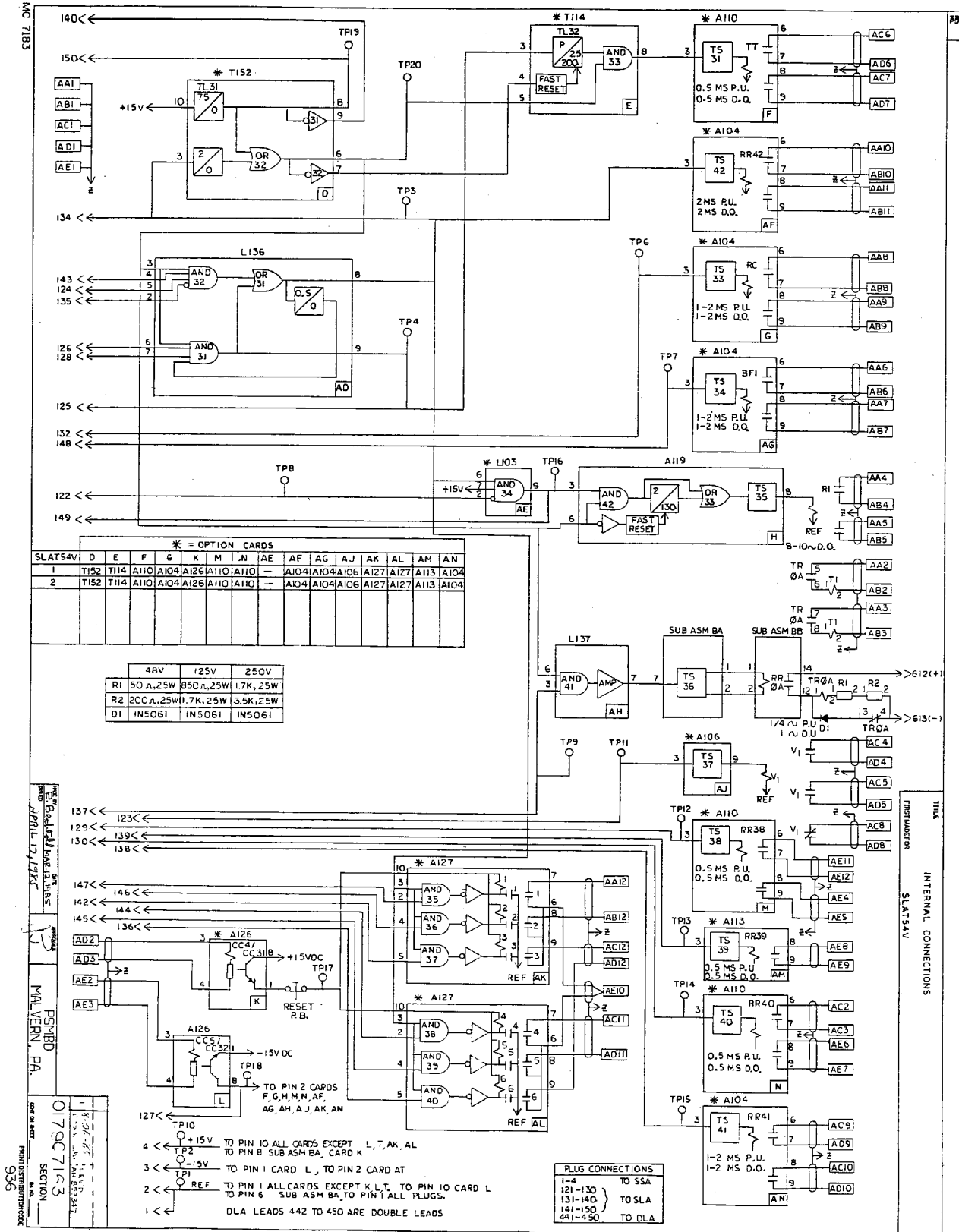

Fig. 2 (0179C7163-0) Internal Connections for the Type SLAT54V Relay

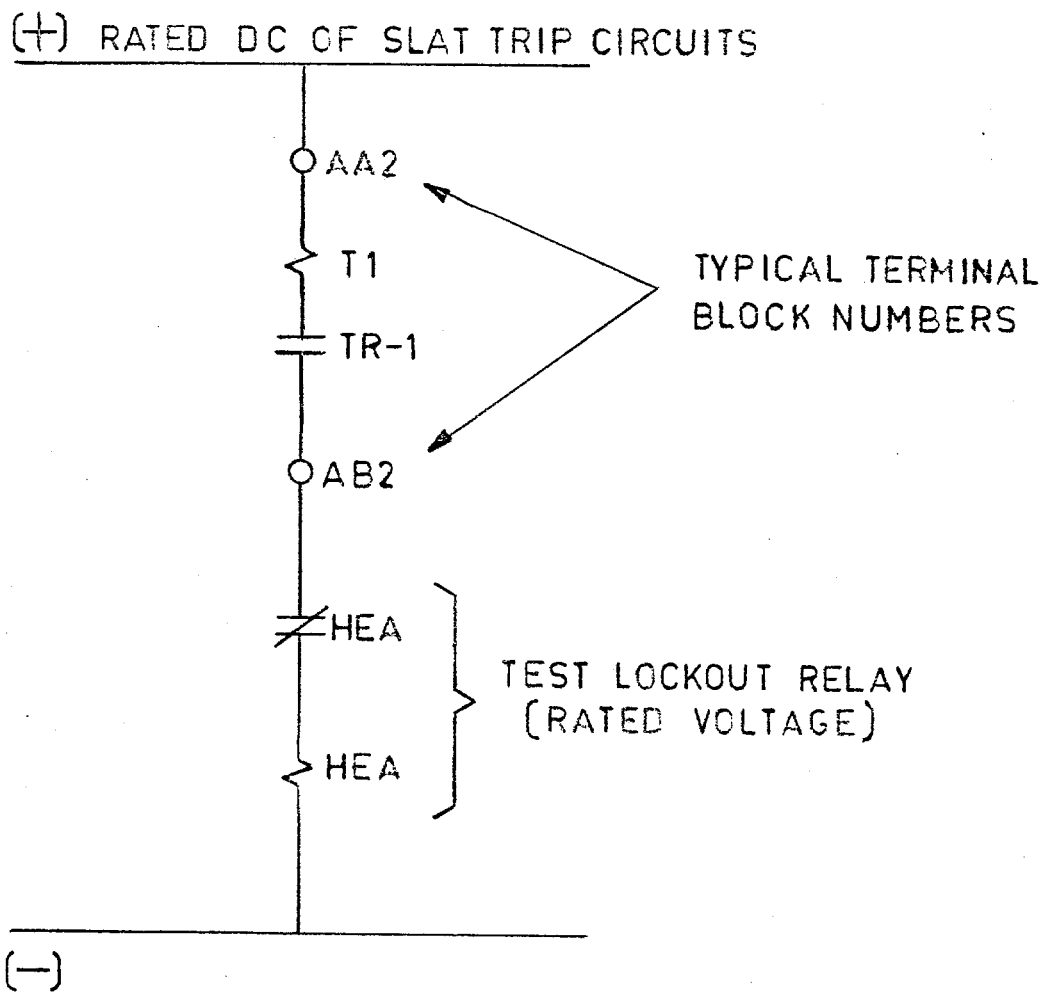

Fig. 4 (0257A8788-0) Typical Trip Circuit Test Connections for Relays with Trip Contacts

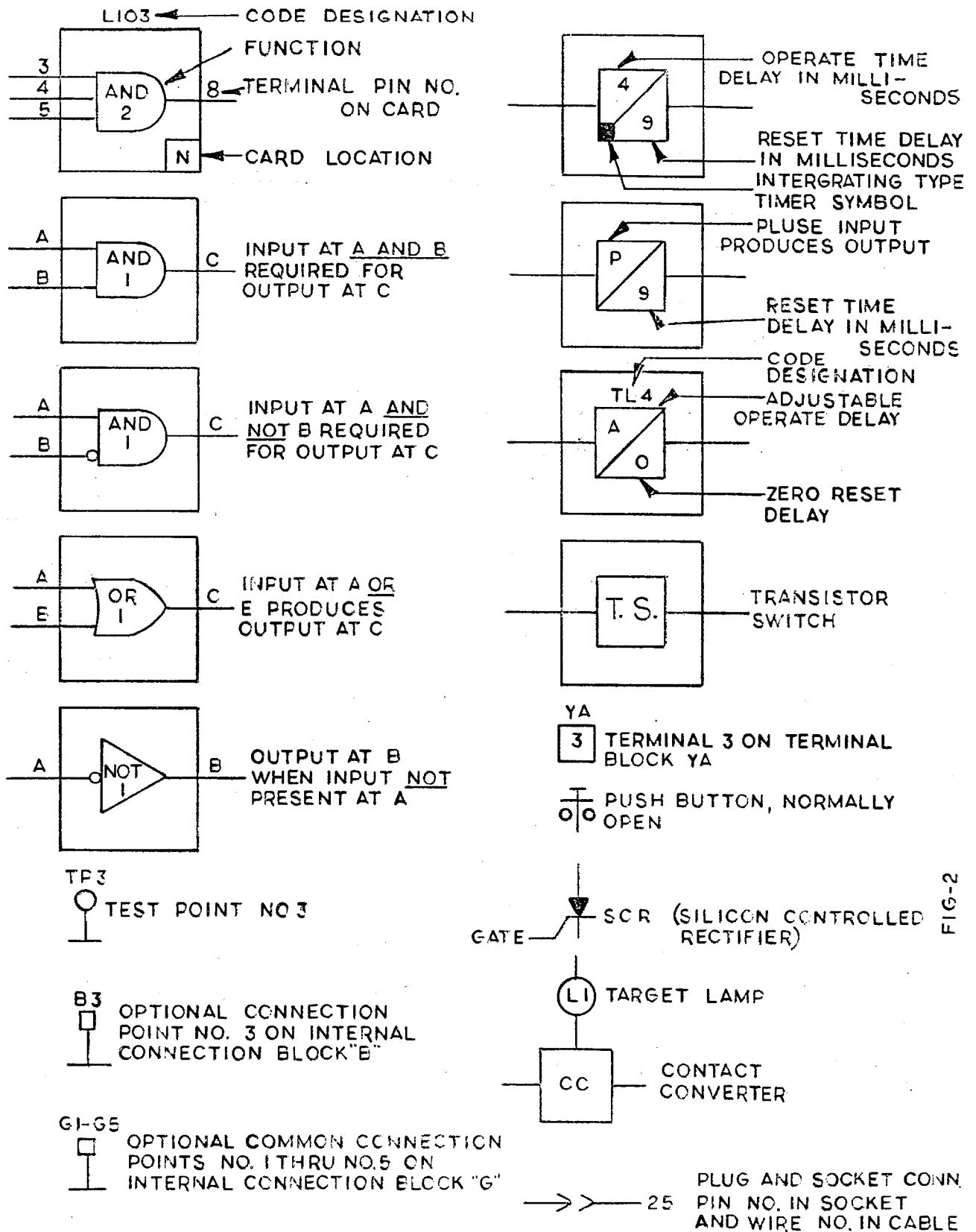
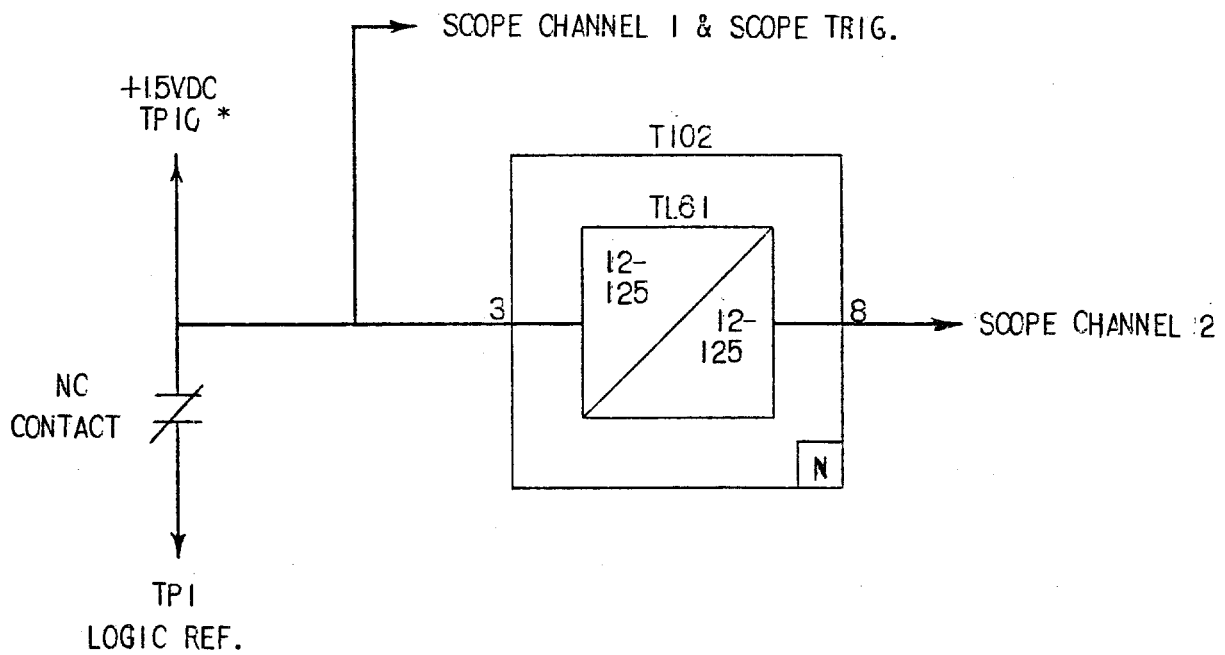

FIG-2

Fig. 5 (0227A2047-1) Logic and Internal Connection Diagram Legend



* THE 15VDC SIGNAL AT PIN 10 HAS A CURRENT LIMITING RESISTOR MOUNTED ON THE TEST CARD.

Fig. 6 (0246A7987-0) Logic Timer Test Circuit