



INSTRUCTIONS

GEK-65694A
Supersedes GEK-65694

STATIC CURRENT/VOLTAGE RELAY

TYPE SLCV61A

GENERAL  ELECTRIC

CONTENTS

	<u>PAGE</u>
DESCRIPTION	3
APPLICATION	3
RATINGS	5
BURDENS	5
RANGES	5
CONSTRUCTION	6
RECEIVING, HANDLING AND STORAGE	6
INSTALLATION TESTS	6
CAUTION	6
GENERAL	7
OPERATIONAL CHECKS	7
TEST CARD ADAPTER	7
OVERALL EQUIPMENT TESTS	7
OPERATING PRINCIPLES AND TEST INSTRUCTIONS	8
I _M FUNCTIONS	8
I FUNCTIONS	9
I ₃₀ FUNCTION	10
GROUND FUNCTIONS	10
SEQUENCE VOLTAGE BALANCE SETTING	11
SEQUENCE CURRENT NETWORK CHECKS	12
ANGLE OF MAXIMUM REACH SETTING	13
TIMER CARD SETTINGS	13
D ₂ B NEGATIVE SEQUENCE DIRECTIONAL BLOCKING UNIT	13
D ₂ B SETTINGS	14
M ₁ B POSITIVE SEQUENCE MHO BLOCKING UNIT	15
M ₁ B SETTINGS	16
POLARIZING PHASE SHIFT ADJUSTMENT	17
M ₁ B REACH CALIBRATION	18
M ₁ B OFFSET CALIBRATION	18
M ₁ B MHO CHARACTERISTIC PLOTTING	19
V ₁ FUNCTION	21
UNDERVOLTAGE LEVEL DETECTOR FUNCTIONS, U/V ØA, U/V ØB AND U/V ØC	23
PERIODIC TESTS AND ROUTINE MAINTENANCE	24
PERIODIC TESTS	24
TROUBLESHOOTING	24
SPARE PARTS	24

STATIC CURRENT/VOLTAGE RELAY

TYPE SLCV61A

DESCRIPTION

The Type SLCV61A relay is a rack-mounted solid-state current/voltage relay, with positive and negative sequence blocking functions, various overcurrent functions, and voltage level functions for use in conjunction with other solid state relays, a test panel and a power supply in transmission line protection schemes.

APPLICATION

The SLCV61A relay may be used in any scheme including those involving single pole tripping.

The I_{MA} , I_{MB} and I_{MC} overcurrent functions are sensitive, adjustable current detectors. Their purpose is to determine, in conjunction with U/VA, B and C, which breaker poles are closed (or opened) by detecting the presence (or absence) of current in each phase. The I_M functions supervise the distance relays in coordination with $I_{3\phi}$, and can determine when one pole is open.

The SLCV61A provides the blocking functions in a directional comparison blocking or directional comparison hybrid scheme. Various overcurrent functions and a voltage function are also included. A description based on application considerations for each included function is provided below.

I_A , I_B and I_C are direct tripping functions, typically set for a level 25 percent above the current for external three phase faults or load swings. The AND functions, AND87, AND88 and AND89, along with OR81 provide the necessary logic to determine that more than one phase is faulted. The AND functions, AND84, AND85 and AND86, are supervised by the G4 function to establish that the fault involves ground and permit each phase overcurrent function to trip its own phase.

$I_{3\phi}$ is a three phase, non-directional overcurrent function that serves the following purposes:

- (a) It provides a seal-in function that serves to keep the trip bus energized as long as $I_{3\phi}$ is picked up.
- (b) It may be used to provide supervision to the phase mho tripping functions.

The seal-in (a) is required to insure that the trip bus, and consequently the breaker failure initiate function (BFI), will remain energized during close-in (zero voltage) faults under a breaker failure condition. When $I_{3\phi}$ is used to provide the seal-in function alone, it must be set sensitively enough to detect the minimum

These instructions do not purport to cover all details or variations in equipment nor to provide for every possible contingency to be met in connection with installation, operation or maintenance. Should further information be desired or should particular problems arise which are not covered sufficiently for the purchaser's purposes, the matter should be referred to the General Electric Company.

To the extent required the products described herein meet applicable ANSI, IEEE and NEMA standards; but no such assurance is given with respect to local codes and ordinances because they vary greatly.

close-in three phase fault. If $I_{3\phi}$ is used to provide supervision to the phase mho tripping functions (b), it must be set to detect all faults in the protected line section, in which case, the setting for seal-in purposes will automatically be met. Supervision of the phase mho functions by $I_{3\phi}$ is used to provide added security to the scheme and also to prevent undesired tripping by the phase mho functions if AC potential is suddenly lost. If the setting required for supervision purposes is above full load, then protection against undesired tripping on loss of AC potential will be in effect at all times; otherwise, the protection will be only partially effective. It must be remembered that the phase mho functions could still produce undesired tripping if an external fault occurred during the time that the AC potential is lost. $I_{3\phi}$ responds to the highest of the three currents, I_1 , I_2 or I_3 .

G1 is a non-directional zero sequence overcurrent function that is typically used to initiate carrier starting and so block tripping during external ground faults.

G2 is a ground overcurrent function which supervises the ground distance relays. Typically it is set below two-thirds of the minimum zero sequence fault current for which the ground distance relays are required to operate.

When both G1 and G2 overcurrent functions are used, the settings of G1 and G2 must be coordinated so that G1 will operate and initiate a carrier blocking signal on the occurrence of faults behind G1 before G2 at the other end can operate to initiate tripping. Because G1 and G2 are similar types of units, proper time coordination will be assured if the G1 function is set more sensitively than G2.

G4 is a zero sequence, non-directional, direct trip instantaneous overcurrent function that is intended to provide direct tripping for heavy ground faults. The G4 function must be set to operate at 125 percent or more of the maximum external ground fault current ($3I_o$). Because G4 is non-directional, it is necessary to consider faults at the bus directly behind the relay as well as at the remote terminal.

$D_2(B)$ is a negative sequence directional unit looking away from the protected line section. $D_2(B)$ provides the blocking function for external unbalanced faults behind the relay.

$M_1(B)$ is a positive sequence mho unit looking away from the protected line section. It provides blocking for external balanced faults behind the relay location.

V_1 is a positive sequence level detector operated by a single input quantity from a positive sequence filter network. It is used as a voltage level detector or can be used in a line pickup scheme.

U/VA, U/VB and U/VC are undervoltage level detectors used to determine open pole conditions, or in conjunction with I_M functions, weak infeed conditions.

Specific recommendations for setting the SLCV61A functions are discussed in the overall logic description of the particular relay equipment involved.

RATINGS

The Type SLCV61A relay is designed for use in an environment where the ambient temperature around the relay case is between minus 20°C and plus 65°C.

The Type SLCV61A relay requires a plus and minus 15 volt DC power source which can be obtained from a Type SSA50/51 power supply.

The current circuits of the Type SLCV61A relay are rated for five amperes, 60 hertz continuous duty, and have a one-second rating of 300 amperes.

The potential circuits of the Type SLCV61A relay are rated for 120 volts phase-to-phase, 60 hertz.

BURDENS

DC

The Type SLCV61A relay presents a maximum burden to the Type SSA power supply of:

200 milliamperes from the plus 15 volt DC supply
 100 milliamperes from the minus 15 volt DC supply

AC

POTENTIAL	5 AMPERE, 60 HERTZ RELAY
\emptyset A-N \emptyset B-N \emptyset C-N	25.5K ohms \sphericalangle 82° 25.5K ohms \sphericalangle 82° 25.5K ohms \sphericalangle 82°
\emptyset A \emptyset B \emptyset C 3I0	0.001 ohms \sphericalangle 10°

RANGES

The ranges given in this section are typical for the SLCV61A relay.

I _{MA} , I _{MB} , I _{MC}	0.6 - 15.0 amps
I _A , I _B , I _C	4.0 - 80.0 amps
I _{3\emptyset}	1.0 - 14.0 amps
G1	0.4 - 3.0 amps
G2	0.5 - 6.0 amps
G4	2.5 - 40.0 amps

D ₂ (B)	0.5 - 1.0 I ₂ Z compensation
	15, 30, 45 or 60 ohm reach on I ₂ Z
M ₁ (B)	10, 20, 30 or 40 ohm reach blocking direction
	0, 2 or 4 ohm offset blocking direction
	0, 2 or 4 ohm offset tripping direction
	0.5, 0.75, 1.0 or 2.0 amps pickup supervision
V ₁	6.0 - 140.0 volts RMS
U/VA, U/VB, U/BC	6.7 - 95.0 volts RMS

CONSTRUCTION

The SLCV61A relay is packaged in an enclosed metal case with hinged front cover and removable top cover. The outline and mounting dimensions of the case and the physical location of the components are shown in Figure 3 and 4 respectively.

The SLCV61A relay contains printed circuit cards which plug in from the front of the unit. The card sockets are marked with letter designations or addresses (D, A, AE, AF, etc.) which appear on the guide strips in front of each socket, on the component location drawing, on the internal connection diagram, and on the printed circuit card itself. The test points (TP1, TP2, etc.) shown on the internal connection diagram are connected to instrument jacks on test cards in positions T and AT with TP1 at the top of the AT card. TP1 is connected to relay reference. TP10 is connected to the plus 15 volt DC bus through a 1.5K resistor. This resistor limits the current when TP10 is used to supply a logic signal.

The current and voltage circuits are connected to the relay via 12-point terminal blocks on the rear of the unit. These blocks are identified as RA (current) and RB (voltage).

RECEIVING, HANDLING AND STORAGE.

These relays will normally be supplied as part of a static relay equipment, mounted in a rack or cabinet with other static relays and test equipment. Immediately upon receipt of a static relay equipment, it should be unpacked and examined for any damage sustained in transit. If injury or damage resulting from rough handling is evident, file a damage claim at once with the transportation company and promptly notify the nearest General Electric Sales Office.

Reasonable care should be exercised in unpacking the equipment. If the equipment is not to be installed immediately, it should be stored indoors in a location that is free from moisture, dust, metallic chips, and severe atmospheric contaminants.

Just prior to final installation the shipping support bolt should be removed from each side of all relay units, to facilitate possible future unit removal for maintenance. These shipping support bolts are approximately eight inches back from the relay front panel. **STATIC RELAY EQUIPMENT, WHEN SUPPLIED IN SWING RACK CABINETS, SHOULD BE SECURELY ANCHORED TO THE FLOOR OR TO THE SHIPPING PALLET TO PREVENT THE EQUIPMENT FROM TIPPING OVER WHEN THE SWING RACK IS OPENED.**

INSTALLATION TESTS

CAUTION

THE LOGIC SYSTEM SIDE OF THE DC POWER SUPPLY USED WITH MOD III STATIC RELAY EQUIP-MENT IS ISOLATED FROM GROUND. IT IS A DESIGN CHARACTERISTIC OF MOST ELECTRONIC INSTRUMENTS THAT ONE OF THE SIGNAL INPUT TERMINALS IS CONNECTED TO THE INSTRUMENT CHASSIS. IF THE INSTRUMENT USED TO TEST THE RELAY EQUIPMENT IS ISOLATED FROM GROUND, ITS CHASSIS MAY HAVE AN ELECTRICAL POTENTIAL WITH RESPECT TO GROUND. THE USE OF A TEST INSTRUMENT WITH A GROUNDED CHASSIS WILL NOT AFFECT THE TESTING OF THE EQUIPMENT. HOWEVER, A SECOND GROUND CONNECTION TO THE EQUIPMENT, SUCH AS A TEST LEAD INADVERTENTLY DROPPING AGAINST THE RELAY CASE, MAY CAUSE DAMAGE TO THE LOGIC CIRCUITRY. NO EXTERNAL TEST EQUIPMENT SHOULD BE LEFT CONNECTED TO THE STATIC RELAYS WHEN THEY ARE IN PROTECTIVE SERVICE, SINCE TEST EQUIPMENT GROUNDING REDUCES THE EFFECTIVENESS OF THE ISOLATION PROVIDED.

GENERAL

If the SLCV61A relay that is to be tested is installed in an equipment which has already been connected to the power system, disconnect the outputs in the associated Type SLAT relay from the system.

The SLCV61A relay is supplied from the factory either mounted in a static relay equipment or as a separate unit associated with other measuring relays, a Type SSA power supply, and some form of channel equipment. All relay units for a given terminal of static relaying equipment are tested together at the factory, and each unit will have the same summary number stamped on its nameplate.

OPERATIONAL CHECKS

Operation of the SLCV61A unit can be checked by observing the signals at the twenty test points (TP1 to TP20) in the SLCV61A, by observing the operation of the associated channel equipment, or by observing the output functions in the associated Type SLAT tripping relay. The test points are located on the test cards in positions T and AT and are numbered 1 to 20 from top to bottom. TP1 is the reference bus for the logic circuit; TP10 is at plus 15 volts DC. The remaining points are located at various strategic points throughout the logic as shown on the internal connection diagram, Figure 1. Test point voltages can be monitored with a portable high impedance voltmeter, the voltmeter on the test panel of the associated equipment, or an oscilloscope.

TEST CARD ADAPTER

The test card adapter provides a convenient means of gaining access to any pin of a particular card. Detailed information on the use of the test adapter card is included in the card instruction book GEK-34158.

OVERALL EQUIPMENT TESTS

After the SLCV61A relay and the associated static relay units have been individually calibrated and tested for the desired settings, a series of overall operating circuit checks is advisable.

The elementary, overall logic, and logic description for the specific job will be useful for determining the overall operation of the scheme.

Overall equipment tests can be performed by applying alternating current and voltages to the measuring units as specified in the instruction book for the measuring units and checking that proper outputs are obtained from the associated SLAT when measuring units operate. Currents and voltages can be applied at the CTP and PTP on the equipment test panel by means of Type XLA test plugs.

OPERATING PRINCIPLES AND TEST INSTRUCTIONS

I_M FUNCTIONS

Operating Principles:

The I_M functions are single-phase, adjustable, low level current detectors. The pickup level of the detectors is set by the X option plug and potentiometer P20 (upper potentiometer) on the level detector printed circuit card. The X option plug selects the proper pickup current range and P20 provides a vernier adjustment. The pickup range for each X plug position is shown in Table I. When a setting may be obtained in two plug positions, the higher number position should be used.

Testing Procedures:

TABLE I

FUNCTION RANGE	Ø	CARD LOCATION	FIG. 5 CONN*		OUTPUT	POSITION OF OPTION X	PICKUP (AMPERES)
			A	B			
I _{MA} 0.6-15A	A	AA	RA2	RA3	TP14	1	0.6 - 1.7
						2	1.3 - 3.4
						3	3.2 - 8.0
						4	6.5 - 15.0
I _{MB} 0.6-15A	B	AB	RA4	RA5	TP15	1	0.6 - 1.7
						2	1.3 - 3.4
						3	3.2 - 8.0
						4	6.5 - 15.0
I _{MC} 0.6-15A	C	AC	RA6	RA7	TP16	1	0.6 - 1.7
						2	1.3 - 3.4
						3	3.2 - 8.0
						4	6.5 - 15.0

*Jumper C to D.

1. Refer to Table I for the correct X plug tap position for the desired setting. Remove the card from the unit and make the setting (refer to Table I for the card location). Replace the card.
2. Use the test circuit of Figure 5 and the phase A connections of Table I. Monitor output with an oscilloscope as indicated in Table I.
3. Set applied test current to the desired setting level. Adjust P20 on the level detector card to just obtain a pickup at the output test point (approximately four millisecond blocks). Adjusting P20 clockwise increases the pickup level of the function. Increase the test current by 15 percent. Potentiometer P80 (lower potentiometer) can then be adjusted to stretch the blocks to a solid pickup (13-15 volts DC). This sets level detector dropout time.
4. Repeat steps 1, 2 and 3 for the phase B and phase C connections.

I FUNCTIONS

Operating Principles:

The I functions are single phase adjustable, high set overcurrent fault detectors. The pickup level of these overcurrent functions is set by the X option plug and potentiometer P20 (upper potentiometer) on the level detector printed circuit card. The X option plug selects the proper pickup current range and P20 provides a vernier adjustment. The pickup range for each X plug position is shown in Table II. When a setting may be obtained in two plug positions, the higher number tap should be used.

Testing Procedures:

TABLE II

FUNCTION RANGE	CARD LOCATION	OUTPUT TEST POINT	OPTION X TAP	RANGE (AMPS)
I _A 4 - 80 A	AD	TP11	1	4.0 - 38.0
			2	7.0 - 65.0
			3	17.5 - 80.0
			4	35.0 - 80.0
I _B 4 - 80 A	AE	TP12	1	4.0 - 38.0
			2	7.0 - 65.0
			3	17.5 - 80.0
			4	35.0 - 80.0
I _C 4 - 80 A	AF	TP13	1	4.0 - 38.0
			2	7.0 - 65.0
			3	17.5 - 80.0
			4	35.0 - 80.0

1. Refer to Table II for the correct X plug tap position for the desired setting. Remove the card from the unit and make the setting (refer to Table II for the card location). Replace the card
2. Use the test circuit of Figure 5 and the phase A connections of Table I. Monitor output with an oscilloscope as indicated in Table II.
3. Set the applied test current to the desired setting level. Adjust P20 on the level detector card to just obtain pickup at the output test point (approximately four millisecond blocks). Adjusting P20 clockwise increases the pickup level of the function. Potentiometer P80 (lower potentiometer) can then be adjusted to stretch the block to a solid pickup (13-15 volts DC). This sets level detector dropout time.
4. Repeat steps 1, 2 and 3 for the phase B and C connections.

I3Ø FUNCTION

Operating Principles:

The I3Ø function consists of an auction circuit with three single phase current inputs and one level detector card. An output is produced when any one of the phase currents is above the pickup setting of the I3Ø function. The pickup level of this function is set by adjustment of the P1 potentiometer on the level detector printed circuit card.

Testing Procedures;

1. Use the phase A connections of Table I and the test circuit of Figure 5. Set the applied test current to the desired pickup setting level.
2. Adjust P1 on the level detector card in position AM to just obtain pickup at TP17. Adjusting P1 clockwise increases the pickup level of the function.
3. Use the phase B connections of Table I. Raise the current to just obtain pickup at TP17. The test current should be within ten percent of the setting made in step 2.
4. Repeat step 3 using the phase C connections of Table I.

GROUND FUNCTIONS

Operating Principles:

The G1 function is a low-set current level detector. The G2 function is a low-set overcurrent fault detector. The G4 is a high-set overcurrent fault detector. The pickup level of these overcurrent functions is set by the X option plug and potentiometer P20 (upper potentiometer) on the level detector printed circuit card. The X option plug selects the proper pickup current range and P20 provides a vernier adjustment. The pickup range for each X plug position is shown in Table III. When a setting may be obtained in two plug positions, the higher number tap should be used.

Testing Procedures:

TABLE III

FUNCTION RANGE	CARD LOCATION	OUTPUT TEST POINT	OPTION X TAP	RANGE (AMPS)
G1 0.4-3.5 A	AR	TP20	1	0.4 - 1.8
			2	0.46 - 2.4
			3	1.1 - 3.0
			4	1.9 - 3.0
G2 0.5-6.0 A	AP	TP19	1	0.5 - 3.5
			2	0.93 - 4.8
			3	2.2 - 6.0
			4	3.8 - 6.0
G4 2.5-40.0 A	AN	TP18	1	2.5 - 18.0
			2	3.75 - 35.0
			3	9.5 - 40.0
			4	18.5 - 40.0

1. Use the test circuit of Figure 5. Connect point A to RA9, point B to RA10, and jumper point C to point D.
2. Refer to Table III for the correct X plug tap position for the desired setting. Remove the card from the unit and make the setting (refer to Table III for the card location). Replace the card.
3. Set the applied test current to the desired setting level. Adjust P20 on the level detector card to just obtain pickup at the output test point (four millisecond blocks). Adjusting P20 clockwise increases the pickup level of the function. Adjust P80 (lower potentiometer) to stretch blocks into a solid pickup (13-15 volts DC). This sets level detector dropout time. Refer to Table III for the correct test point.

NOTE: If dropout time for the G1 function is set in the SLA logic unit, leave P80 adjusted fully counterclockwise on the G1 level detector card. Refer to the overall logic description for the setting of G1 dropout time.

SEQUENCE VOLTAGE BALANCE SETTING

The purpose of this test is to adjust the trimmer potentiometers P1 and P2. These potentiometers are intended to correct small errors due to the potential source; therefore, it is necessary to set these pots with the unit connected to the system. For preliminary tests before installation, these potentiometers may be left at factory settings.

With the positive sequence voltage connections of Figure 6, observe the wave form at pin 9 on the P133 card (E position) with an oscilloscope. Put E card in an extender card to make this pin available. This voltage should be less than 0.3 volts peak-to-peak and consist primarily of third harmonics. P1 and P2 may be alternately adjusted to lower the magnitude of the signal at pin 9 of E card (to a minimum). Lock P1 and P2 and check that minimum voltage is maintained.

Now using a voltmeter, measure the voltage at pin 8 to relay reference of the P133 card. Reading should be 4.0 to 4.45 volts RMS.

With the negative sequence voltage connections of Figure 6, observe the wave form at pin 8 of the P133 card with an oscilloscope. This voltage should be less than 0.2 volt peak-to-peak and consist primarily of third harmonics.

Now using a voltmeter, measure the voltage at pin 9 to relay reference of the P133 card. Reading should be 7.6 to 8.5 volts RMS.

If a single phase system is used to check the voltage sequence networks, then make up the single phase connections of Figure 6. Note, a single phase connection produces both positive and negative sequence values. Applying relay rated voltage (69 volts RMS ϕ -N) to any particular phase input will produce positive and negative sequence signals per the table associated with the single phase connections of Figure 6.

SEQUENCE CURRENT NETWORK CHECKS

Use the positive sequence current connections of Figure 7 to check the null of the negative sequence current network. Set the current in each phase at relay rated amps. Use an oscilloscope to check the voltage wave form at pin 9 on the P134 card (position F). Put the F card in an extender card to make this pin available. This voltage should be primarily third harmonics and less than 0.3 volts peak-to-peak. Due to the accuracy of the circuit components, no adjustment is provided on these networks.

Now using a voltmeter, measure the voltage at pins 7 and 8 to relay reference of the P134 card. Readings should be 1.33 to 1.47 volts RMS at pin 7, and 7.6 to 8.4 volts RMS at pin 8.

With the negative sequence current connections of Figure 7, observe the wave form at pins 7 and 8 of the P134 card with an oscilloscope. These voltages should be less than 0.1 volt peak-to-peak at pin 7, and 0.6 volt peak-to-peak at pin 8, and consist primarily of third harmonics.

Now using a voltmeter, measure the voltage at pin 9 to relay reference. Reading should be 4.2 to 4.8 volts RMS.

If a single phase system is used to check the voltage sequence networks, then make up the single phase connections of Figure 7. Note, a single phase connection produces both positive and negative sequence values. Applying relay rated current (five amperes RMS) to any particular phase input will produce positive and negative sequence signals per the table associated with the single phase connections of Figure 7.

ANGLE OF MAXIMUM REACH SETTING

The relay reach angle of the SLCV61A is adjusted by means of links on the rear of the relay. The angle can be set for 75 or 85 degrees.

In order to set the polarizing voltage phase shift of the M_1B characteristic, it is necessary to adjust the P80 pot on the F180 card (position K). Refer to M_1B test section.

TIMER CARD SETTINGS

The SLCV61A relay has two timer cards. The T129 card (position M) is used to define the shape of M_1B , the positive sequence mho blocking function. The T129 card (position R) is used to time the duration of positive blocks out of D_2B , the amplitude comparer function, located on the F179 card (position N).

For recommended settings of these timers, refer to the overall logic description for the specific equipment involved.

When setting timers, FIRST REMOVE THE CARD FEEDING THE TIMER. Use the circuit of Figure 8 for timer card testing and adjustment. To test and adjust the T129 card (position M) connect scope trigger and timer input to TP6. Connect scope monitoring probe to TP7 with scope reference connected to TP1. Opening the normally closed contact of Figure 8 applies a plus logic signal to the timer. Pickup time can be measured on the scope and adjusted by turning pot P1 on the T129 card (position M). Turning P1 clockwise increases pickup time. Closing the normally closed contact of Figure 8 removes the plus logic signal from the timer. Dropout time can be measured on the scope and adjusted by turning pot P2 on the T129 card (position M). Turning P2 clockwise increases dropout time. NOTE: It may be necessary to tie pin 4 of the T129 card to reference. Place the T129 card on a card extender and jumper pin 4 to TP1 (reference).

To test and adjust the T129 card (position R), follow the testing instructions above, connecting scope trigger and timer input to TP8 and scope monitoring probe to TP9.

 D_2B NEGATIVE SEQUENCE DIRECTIONAL BLOCKING UNITOperating Principles:

D_2B is a negative sequence directional blocking unit that compares the absolute value of the combined vector quantities $|V_2 + KI_2Z|$ with the absolute value of vector I_2Z . A bias adjustment is available to set overall sensitivity of the comparer.

The comparer card, F179 (position N), produces an output whenever $|V_2 + KI_2Z|$ is greater than $|I_2Z|$ plus bias voltage.

The I_2Z quantity is a voltage proportional to the negative sequence current in the line. This voltage is derived from voltages maintained on the secondaries of CTs TD, TE and TF across low impedance phase shifting loads. These CT secondary per-phase "voltages" are then processed through the negative sequence networks on

the P134 card (position F) to develop I_2Z with the Z component defined by the Y link on the P136 card (position H). A reach, Z, of 15 ohms, 30 ohms, 45 ohms or 60 ohms is available by setting the Y link to position B, C, D or E, respectively. Refer to Table IV.

The K component of KI_2Z is set by adjusting the P31 pot on the P136 card (position H). K is adjustable from 0.5 to 1.0, and a recommended setting is contained in the logic description for the specific equipment involved.

To adjust the K component of KI_2Z , apply negative sequence current per Figure 7 (no voltage). Place the F179 card (position N) on a card extender and monitor with an oscilloscope, pins 4 and 7 on the F179 card with scope reference connected to pin 1. Adjust pot P31 on the P136 card (position H) to achieve K value desired for KI_2Z . KI_2Z is monitored at pin 4 and I_2Z is monitored at pin 7.

TABLE IV

D₂B SETTINGS

CARD	CARD POSITION	OPTION PLUG	OPTION PLUG POSITION	(Z) REACH	KZ POT
P136	H	Y	B C D E	15 ohms 30 ohms 45 ohms 60 ohms	P31

The V_2 quantity is a voltage proportional to the negative sequence voltage on the line at the relay terminal. V_2 is derived from the three phase-to-neutral voltages at the relay input, TA, TB and TC secondaries, and the negative sequence networks on the P133 card (position E).

Testing Procedures:

For the following tests, put the F179 card (position N) in a card extender to make pins available for oscilloscope monitoring.

The amplitude comparer card F179 (position N) has two adjustable pots on it. P1 is designed to balance the parallel circuit path gains that feed the final summing amplifier. It is factory set by zeroing the bias circuit input (P2 pot on F179 card) and adjusting K to 1, then applying negative sequence currents (no voltage) per Figure 7. Identical signals appear at the pin 4 and pin 7 inputs to the F179 card. If the input voltages at pins 4 and 7 are not identical, adjust pot P31 on the P136 card (position H) to make signals equal in magnitude. Pot P1 on the F179 card (position N) is then adjusted so that pin 8 on the F179 card (position N) signal just goes to zero. This pot should need no field adjustment.

P2 is the bias adjustment pot and is designed to set the overall sensitivity of the $D_2(B)$ function. Refer to the overall logic description for the specific equipment involved for recommendation on setting $D_2(B)$ sensitivity. For sensitivity adjustment, make the negative sequence voltage connections of Figure 6 (no current).

Reduce the voltage to the level of desired sensitivity. Adjust pot P2 on the F179 card (position N) to just get four to five millisecond positive blocks out of pin 8. For setting timer card T129 (position R) refer to the section on TIMER CARD SETTINGS, and the overall logic description.

For the directional action check, make the single phase connections of Figure 12 and connect TP13 to reference. Adjust the K component of KI_2Z to 1.0 and comparer bias to 0.5 volts. Set the timer card T129 (position R) to pick up in 425 milliseconds. Place the Y option of the P136 card (position H) in the B link position (15 ohms). Apply three amperes and 45 volts RMS, and swing the phase shifter, checking that $D_2(B)$ stays picked up from approximately 327° through 90° to 203° (plus or minus 15 degrees at either end). $D_2(B)$ can be monitored at TP9. Pickup is defined as a signal which steps from 0-1 volt DC to 12-15 volts DC.

NOTE: When applying single phase voltages and currents, the polarity of V_2 is reversed from the V_2 generated by an unbalanced fault; therefore, $D_2(B)$ pickup appears in the tripping direction.

After directional tests have been completed, the final K component of KI_2Z , comparer bias adjustments and timer (position R) should be made, as described above.

M₁B POSITIVE SEQUENCE MHO BLOCKING UNIT

Operating Principles:

The M₁B positive sequence blocking unit employs positive sequence voltage and current networks to obtain the I_1Z , I_1Z' and V_1 signals used to derive the mho characteristic. The principle used to derive the mho characteristic is illustrated in Figure 9.

The I_1Z or I_1Z' quantity is a voltage proportional to the positive sequence current in the line. This voltage is derived from current related voltages maintained on the secondaries of CTs TD, TE and TF across low impedance phase shifting loads. These CT secondary per-phase "voltages" are then processed through the positive sequence networks on the P134 card (position F) to develop I_1Z with the Z and Z' components, or relay reaches, defined by the X, Y and Z option plugs on the P135 card (position G).

A blocking reach (Z) of 10 ohms, 20 ohms, 30 ohms or 40 ohms is available by setting the X option to position B, C, D or E, respectively. Refer to Table V.

A blocking direction offset reach (Z') of zero ohms, two ohms or four ohms is available by setting the Y option to position A, C or E, respectively, and by placing link A on the J101 card (position J) to the 4-6 position. Refer to Table V.

A tripping direction offset reach (Z') of zero ohms, two ohms or four ohms is available by setting the Z option to position A, C or E, respectively, and by placing link A on the J101 card (position J) to the 5-6 position. Refer to Table V.

TABLE V

M₁B SETTINGS

FUNCTION	CARD	CARD POSITION	OPTION PLUG	OPTION PLUG POSITION	(Z OR Z') REACH	COMMENTS
Blocking Reach	P135	G	X	B C D E	10 ohms 20 ohms 30 ohms 40 ohms	
Blocking Direction Offset	P135	G	Y	A C E	0 ohms 2 ohms 4 ohms	Place link A on the J101 card (position J) to 4-6 position.
Tripping Direction Offset	P135	G	Z	A C E	0 ohms 2 ohms 4 ohms	Place link A on the J101 card (position J) to 5-6 position.
Current Level Supervision	P136	H	X	B C D E	0.5 amp I ₁ 0.75 amp I ₁ 1.0 amp I ₁ 2.0 amp I ₁	Place link B on the J101 card (position J) to 8-9 position*

*With link B in the 7-8 position, there is no current level supervision.

The V_1 quantity is a voltage proportional to the positive sequence voltage on the line at the relay terminal. V_1 is derived from the three phase to neutral voltages at the relay input, and the positive sequence networks on the P133 card (position E).

The quantity $(I_1Z - V_1)$ is the vector difference of these two quantities. The quantity $(I_1Z' + V_1)$ is the vector sum of these quantities.

Assuming the circular characteristic of Figure 9, the angular difference between vectors $(I_1Z - V_1)$ and $(I_1Z' + V_1)$ is less than 90 degrees for an impedance point internal to the relay characteristic, equal to 90 degrees at the balance point and greater than 90 degrees for an external impedance point for which the blocking unit should not operate. The quantities V_1 , I_1Z and I_1Z' are combined in operational amplifiers on filter card F180 (position K) and converted into line frequency positive and negative blocks of voltage representing $(I_1Z - V_1)$ and $(I_1Z' + V_1)$. The coincidence of these blocks is then measured. Blocks which are 90 degrees out of phase are coincident for 4.17 milliseconds (60 hertz). Blocks which are less than 90 degrees out of phase are coincident for more than 4.17 milliseconds (60 hertz). Blocks which are more than 90 degrees out of phase are coincident for less

than 4.17 milliseconds (60 hertz). The mho function consists of a filter card, a coincidence card and a timer card, which measures coincidence of $(I_1Z - V_1)$ and $(I_1Z + V_1)$. This group of cards is shown on the relay internal diagram, Figure 1, and their operating quantity wave forms are shown on Figure 10. If the characteristic has no offset, the operating principle remains the same as described, except I_1Z' is zero.

The overall shape of the characteristic can be altered by the pickup time setting of the T129 timer card (position M). A pickup time of 4.17 milliseconds (60 hertz) will produce a circular mho characteristic. A pickup time of more than 4.17 milliseconds (60 hertz) will produce a contracted (lens-like) mho characteristic. A pickup time of less than 4.17 milliseconds (60 hertz) will produce an expanded (tomato-like) mho characteristic.

For recommendations on timer settings, refer to the overall logic description for the specific equipment involved.

Supervision of the M_1B characteristic pickup below a set current level is available. M_1B supervision can be set at 0.5, 0.75, 1.0 or 2.0 amperes of positive sequence current by placing the X option plug on the P136 card (position H) in the B, C, D or E positions, respectively, and putting link B on the J101 card (position J) in the 8-9 position. Placing link B on the J101 card (position J) in the 7-8 position removes current level supervision from the M_1B function. Refer to Table V.

The angle of maximum reach of the mho characteristic of the M_1B function is established by setting the three links on the back of the SLCV61A relay. The polarizing quantity $(I_1Z' + V_1)$ can also be phase shifted from 0° to 20° leading by adjusting pot P80 on the F180 card (position K). The effect of introducing polarizing phase shift on an expanded (tomato-like) mho characteristic is illustrated in Figure 11.

Testing Procedures:

The F180 filter card (position K) contains on it a D link. When this link is in the 1 position, a memory filter is inserted into the operate $(I_1Z - V_1)$ circuit. This memory filter gives quick operation of the M_1B function during close in, low voltage, three phase faults. This filter, however, lowers relay sensitivity during tests. It is recommended that during the following M_1B tests, the D option be moved to the 2 position. Upon completion of these tests, return option D to the 1 position.

POLARIZING PHASE SHIFT ADJUSTMENT

A polarizing quantity phase shift of from zero degrees to 20 degrees leading can be obtained by adjusting the upper pot, P80, on the F180 card (position K) from fully counterclockwise to fully clockwise. Polarizing phase shift can be set using the connections of Figure 6 and observing the outputs at pins 8 and 9 of the F180 card. Adjustment of P80 will secure the waveforms shown in Figure 13. The waveforms will shift by 0.046 milliseconds per degree of phase shift (60 hertz).

M₁B REACH CALIBRATION

For checking and adjusting the M₁B characteristic, use the connections of Figure 12. First set the relay angle of maximum reach to 85 degrees on links 1, 2 and 3 on the back of the relay, and adjust pot P80 on the F180 card (position K) to obtain a 0° polarizing phase shift as described above. Next, set the reach of the relay in the blocking direction (Z) to ten ohms by setting the X option plug on the P135 card (position G) to position B. Set link B on the J101 card (position J) to the 7-8 position (no current supervision). Set Y and Z options on the P135 card (position G) to position A (no offset).

Place the F180 card (position K) into a card extender. Connect an oscilloscope probe to pin 8 and scope reference to pin 1.

Using the test setup of Figure 12, apply three amperes accurately balanced (for three phase test) or nine amperes for single phase test. Set the phase angle meter by adjusting the phase shifter, to read the angle of maximum reach of the relay in the blocking direction. With balanced three phase voltage applied (for three phase test) or single phase voltage applied (for single phase test), lower the voltage to get a 12-15 volt DC pickup at test point TP7. Note: TP3 and TP4 must be at reference for TP7 to pick up. The voltage at nulling is defined by the equation:

$$V_{\phi-N} = IZ \quad (\text{Eq. 1})$$

where:

$V_{\phi-N}$ = applied voltage (phase-to-neutral) (RMS)
 I = applied phase current (RMS)
 Z = relay reach setting

(For the above stated conditions, $V_{\phi-N} = 30.0$ volts RMS)

If TP7 does not just pick up at the above calculated voltage, set the applied voltage per the above calculation, and adjust pot P10 (lower pot) on the F180 card to just get a pickup at TP7.

M₁B OFFSET CALIBRATION

To calibrate the offset reach of the relay, place the Z option on the P135 card (position G) to position E (four ohms), and set link A on the J101 card (position J) to the 5-6 position. Using the test setup of Figure 12, apply three amperes accurately balanced (for three phase test) or nine amperes for single phase test. Set the phase angle meter by adjusting the phase shifter to read the angle of maximum reach of the relay in the tripping direction. With balanced three phase voltages applied (for three phase test) or single phase voltage applied (for single phase test), lower the applied voltage to get a 12-15 volt DC pickup at test point TP7. The voltage at pickup is defined by Equation 1. For this setup, the pickup voltage is 12.0 volts RMS (phase-neutral). If TP7 does not pickup at this voltage, adjust pot P60 (middle pot) on the F180 card to just get a pickup at TP7. Return Z option on the P135 card (position G) to position A.

M₁B MHO CHARACTERISTIC PLOTTING

To obtain any points on the relay characteristic, observe the following procedure:

Determine which general category of relay characteristic you are interested in from the two listed below:

Category ICircular Characteristics with No Polarizing Phase Shift or Offset

1. Set timer T129 (position M) pickup per TIMER CARD SETTINGS section to 4.17 milliseconds (60 hertz). This will generate a circular characteristic.
2. Set a zero degree polarizing phase shift as described above.
3. Place option links Y and Z on the P135 card (position G) in positions A.
4. Set up the test circuit of Figure 12.
5. Set currents to three amperes accurately balanced (for three phase test) or nine amperes for single phase test.
6. Connect an oscilloscope between the characteristic output test point (TP7) and reference, TP1.
7. Set phase angle meter at the specific angle of interest by rotating the phase shifter.
8. Adjust the gang variac until the characteristic function output fully picks up. Note that the point just at the verge of pickup, as read on the voltmeter (V), defines the characteristic.

All necessary points can be obtained by simply repeating steps 7 and 8 until the characteristic is clearly defined. The relay reach at any angle is given by the equation:

$$V_{\theta-N} = IZ \cos(\theta - \delta)** \quad (\text{Eq. 2})$$

**Within +5%. At angle of maximum reach, relay pull back may be slightly greater.

where:

$V_{\theta-N}$ = applied voltage (phase-to-neutral) (RMS)
 I = applied phase current (RMS)
 Z = relay reach setting in ohms
 θ = angle of maximum reach
 δ = test angle

Category II

Non-Circular Characteristics with Polarizing Phase Shift and Offset

1. For non-circular characteristics, adjust timer T129 (position M) to the desired pickup level as described under TIMER CARD SETTINGS section.

NOTE: In calculating timer card settings in degrees, multiply pickup setting by
 1 millisecond = 21.6 degrees (60 hertz)

2. For characteristics employing polarizing phase shift, set the required polarizing phase shift as described above.
3. For characteristics employing offset, set the desired offset reach as described in the Operating Principles section of the M1B unit.

The pickup voltage must now be calculated by solving the following quadratic equations for the relay reach at any angular difference between applied voltage and current.

$$Z^2 - Z \frac{Z_F \sin (\theta - \delta + \tau - \theta_p) + Z_R \sin (\theta - \delta - \tau + \theta_p)}{\sin (\tau - \theta_p)} - Z_F Z_R = 0 \quad (\text{Eq. 3})$$

for $(\theta - 180) \leq \delta \leq \theta$, and

$$Z^2 - Z \frac{Z_F \sin (\theta - \delta - \tau - \theta_p) + Z_R \sin (\theta - \delta + \tau + \theta_p)}{\sin (-\tau - \theta_p)} - Z_F Z_R = 0 \quad (\text{Eq. 4})$$

for $\theta < \delta < (\theta + 180)$

where:

- Z = Relay reach in ohms
- Z_F = Blocking direction reach of the relay in ohms
- Z_R = Offset reach in ohms (positive in the tripping direction)
(negative in the blocking direction)
- θ = Angle of maximum reach as set on the relay in degrees
- θ_p = Polarizing phase shift in degrees (leading, positive)
- τ = Timer setting in degrees
- δ = Angle of interest (phase angle meter setting)

The operating point voltage (V_{θ-N}) at the angle under test is:

$$V_{\theta-N} = IZ^{**}$$

**Within +5%. At angle of maximum reach, relay pull back may be slightly greater.

NOTE: If characteristic under consideration has no offset, set Z_R to zero (Eq. 3 and 4). If characteristic under consideration has no polarizing phase shift, set θ_p to zero (Eq. 3 and 4). If characteristic under consideration is circular, set τ to 90° (4.16 milliseconds) (Eq. 3 and 4).

Example

Assume: A relay reach of ten ohms (Z_F)
 A relay offset reach of two ohms in the tripping direction (+) (Z_R)
 An angle of maximum reach of 75 degrees (θ)
 A polarizing phase shift of 15 degrees (ϕ_p)
 A characteristic timer setting of 5.5 milliseconds x 21.6 degrees/milliseconds = 118.8 degrees (τ)

Now, calculating the relay reach (Z) at a voltage leading current angle of 45 degrees (ξ)

(because $(75^\circ - 180^\circ) \leq 45^\circ \leq (75^\circ)$ use Eq. 3)

$$Z^2 - Z \frac{10 \sin (75 - 45 + 118.8 - 15) + 2 \sin (75 - 45 - 118.8 + 15)}{\sin (118.8 - 15)} - (10)(2) = 0$$

$$Z^2 - Z(5.45) - 20 = 0$$

For a quadratic of the form:

$$Z^2 + bZ + C = 0$$

$$Z = \frac{-b \pm \sqrt{b^2 - 4C}}{2}$$

Therefore, $Z = 7.96$ or -2.51 (ignore negative roots), and

$$V_{\phi-N} = IZ = 39.8 \text{ volts } \phi-N \text{ RMS at five amperes test current.}$$

The M_{1B} function operating points can then be checked using steps 4 through 8 (under Category I, above).

CAUTION: AT THE END OF ALL M_{1B} CHECKS AND TESTS, AND BEFORE RETURNING RELAY TO SERVICE, RETURN THE D OPTION ON THE F180 CARD (POSITION K) TO THE 1 POSITION.

V₁ FUNCTION

Operating Principles:

The V_1 level detector function is operated by a single input quantity from the positive sequence voltage network. The level detector operates on the magnitude of V_1 , independent of phase angle. The level detector has an intentional time delay before resetting when the input, V_1 , drops below the pre-set level. The pickup level is adjusted by the X option plug and potentiometer P2 on the D146 card

(position D). The X option plug selects the proper pickup voltage range and P20 provides a vernier adjustment. The pickup range for each X plug position is shown in Table VI.

Settings for the positive sequence voltage detector are discussed in the overall logic description for the particular equipment involved.

Testing Procedures:

TABLE VI

FUNCTION RANGE	CARD LOCATION	OUTPUT TEST POINT	OPTION X TAP	RANGE Ø-N VOLTS (RMS)
V ₁ 4.0 - 140.0 V Ø-N (RMS)	D	TP5	1 2 3 4	4.0 - 13.5 V 8.0 - 27.5 V 21.25 - 71.0 V 41.25 - 140.0 V *
U/V ØA 6.7 - 95.0 V Ø-N (RMS)	A	TP2	-	6.7 - 95.0 V
U/V ØB 6.7 - 95.0 V Ø-N (RMS)	B	TP3	-	6.7 - 95.0 V
U/V ØC 6.7 - 95.0 V Ø-N (RMS)	C	TP4	-	6.7 - 95.0 V

*See note under step 5 of V₁ pickup adjustment:

1. Use the test circuit of Figure 12 with voltage connections only.
2. Refer to Table VI for the correct X plug tap position for the desired pickup. In the event that two taps provide the desired pickup, choose the higher tap setting.
3. Set the applied test voltage to the desired pickup level.

NOTE: If single phase voltage is applied, three times desired pickup must be applied. Do not use a single phase setup if V₁ pickup is to be set above one-third rated voltage.

4. Connect an oscilloscope input to TP5, output test point, with scope reference connected to TP1.

5. Set P80 fully counterclockwise. Adjust P20 to just get a pickup. Turning P20 clockwise increases pickup level. After pickup is set, readjust P80 to provide a continuous output.

UNDERVOLTAGE LEVEL DETECTOR FUNCTIONS, U/V ØA, U/V ØB AND U/V ØC

Operating Principles:

The undervoltage level detector functions operate from single inputs from the individual phase-to-neutral connected relay potential transformers. The level detectors operate on magnitude only and are independent of phase angle. The undervoltage level detectors have intentional time delay before resetting when the phase-to-neutral input voltage drops below the pickup level. The pickup levels are adjusted by the P1 pots on the D102 cards in positions A, B and C. The pickup range for the undervoltage level detectors is shown in Table VI.

Settings for the undervoltage level detectors are discussed in the overall logic description for the particular equipment involved.

Testing Procedures:

1. Use the single phase test circuit of Figure 12 with voltage connections only.
2. Set the applied test voltage to the desired pickup level.
3. Connect an oscilloscope input to the proper test point, for the level detector being checked or tested per Table VI. Connect scope reference to TP1.
4. Adjust pot P1 on the card under test (per Table VI) to just get a pickup. Turning P1 clockwise increases pickup level.

NOTE: For testing ØA, connect voltage source to RB2-RB3; for ØB, use RB4-RB5; and for ØC, use RB6-RB7.

PERIODIC CHECKS AND ROUTINE MAINTENANCE

PERIODIC TESTS

All functions included in the SLCV61A relay may be checked at periodic intervals using the procedures described in the section covering DETAILED TESTING INSTRUCTIONS. Cable connections between the SLCV61A relay and the associated Type SLA relay can be checked by observing the SLCV61A outputs at test points in the SLA relay.

The following checks are suggested as periodic checks/routine maintenance.

1. Network General Calibration Check
2. MHO Characteristic Plotting on R-X Diagram
3. Current and Voltage Level Detector Pickup Settings

TROUBLESHOOTING

In any troubleshooting of equipment, it should first be established which unit is functioning incorrectly. The overall logic diagram supplied with the equipment shows the combined logic of the complete equipment and the various test points in each unit. By signal tracing, using the overall logic diagram and the various test points, it should be possible to quickly isolate the trouble.

A test adapter card (0149C7259G2) is supplied with each static relay equipment to supplement the prewired test points on the test cards. Use of the adapter card is described in the card instruction book GEK-34158.

A dual-trace oscilloscope is a valuable aid to detailed troubleshooting, since it can be used to determine phase shift, operate and reset times, as well as input and output levels. A portable dual-trace oscilloscope with a calibrated sweep and trigger facility is recommended.

SPARE PARTS

To minimize possible outage time, it is recommended that a complete maintenance program should include the stocking of at least one spare card of each type. It is possible to replace damaged or defective components on the printed circuit cards, but great care should be taken in soldering so as not to damage or bridge-over the printed circuit buses, or overheat the semiconductor components. The repaired area should be recovered with a suitable high-dielectric plastic coating to prevent possible breakdowns across the printed buses due to moisture and dust. The wiring diagrams for the cards in the SLCV61A relay are included in the card book, GEK-34158; the card types are shown on the component location diagram, Figure 3.

NOTES

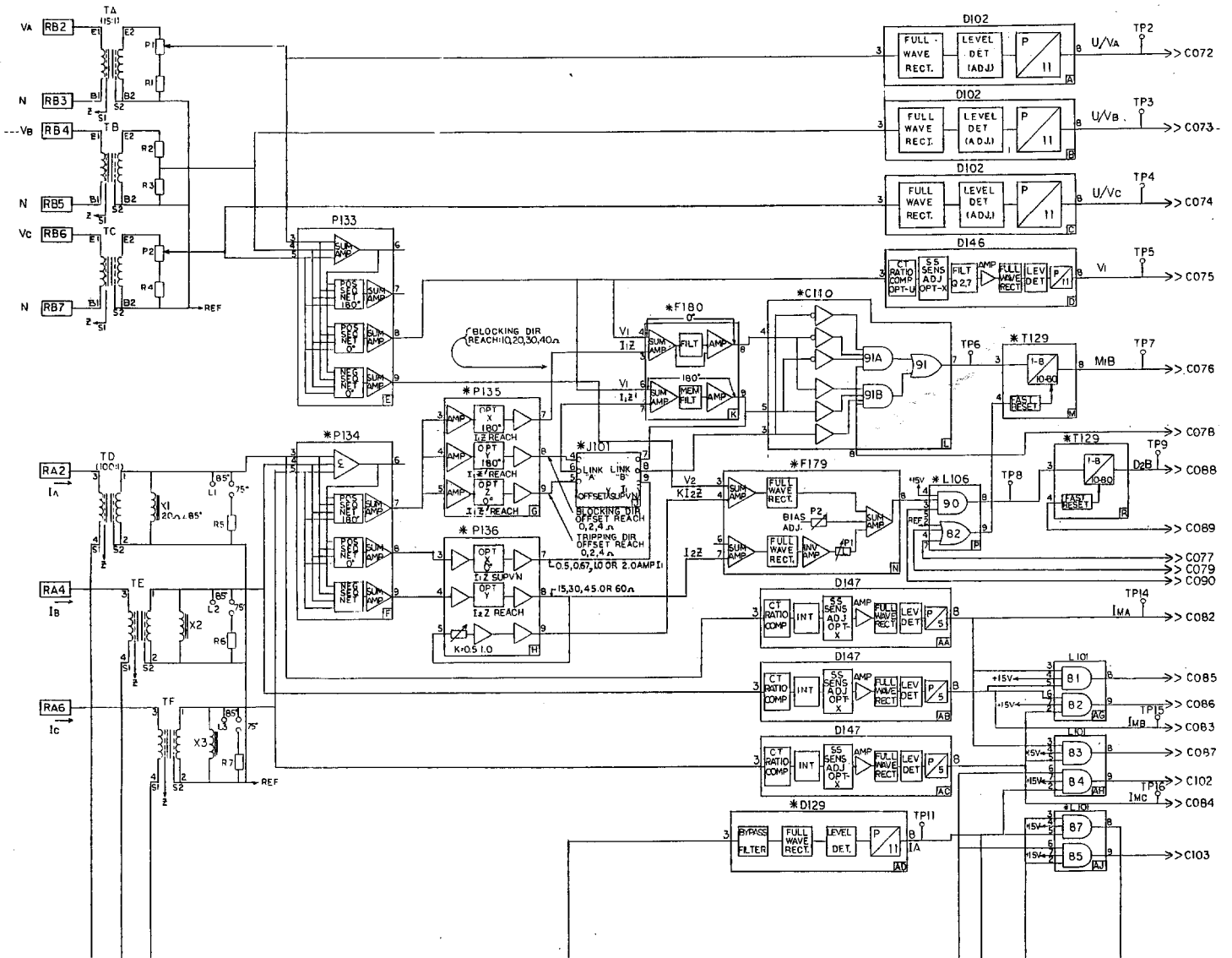

Figure 1A (0145D8633-4) Internal Connection Diagram for the Type SLCV61A Relay

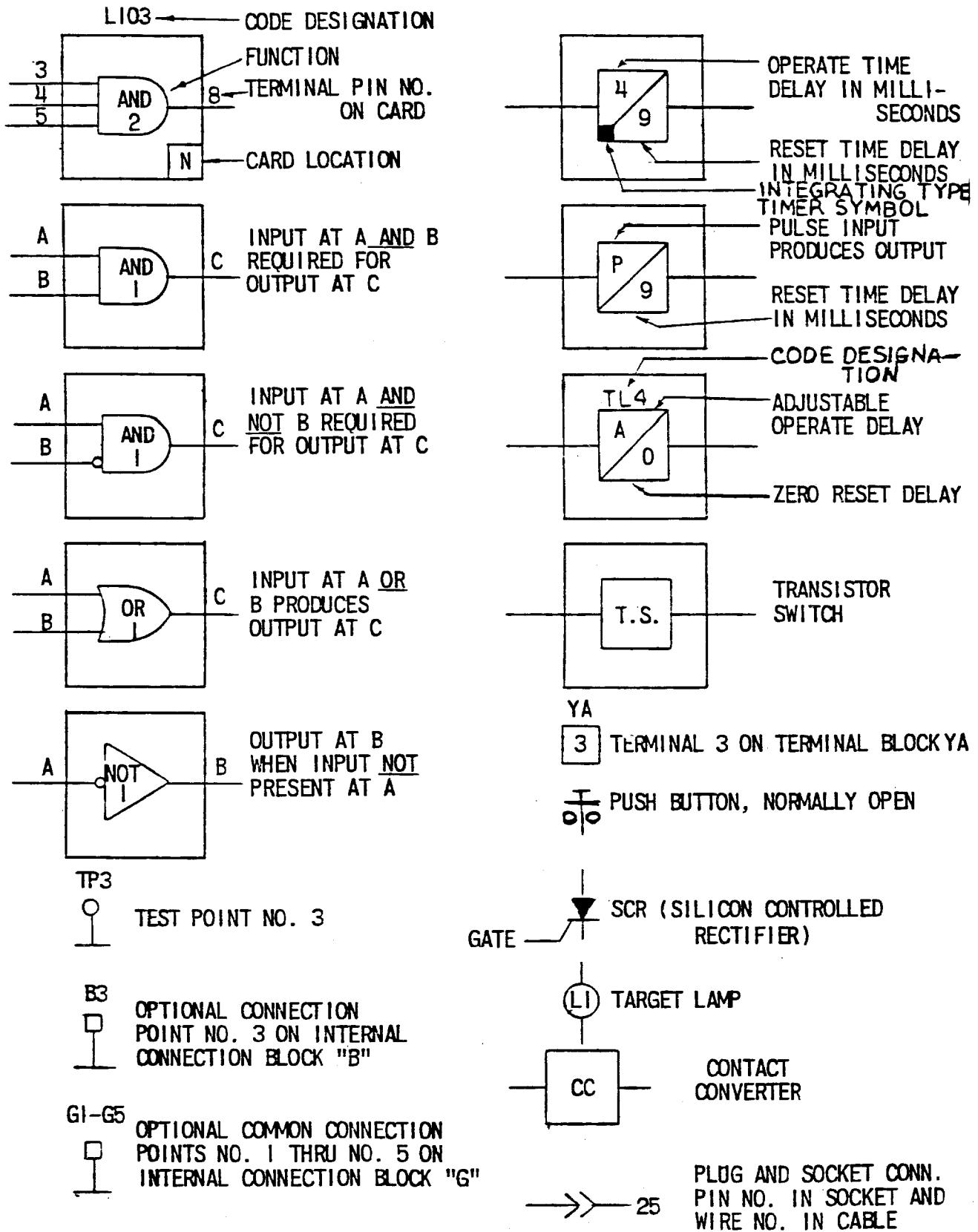
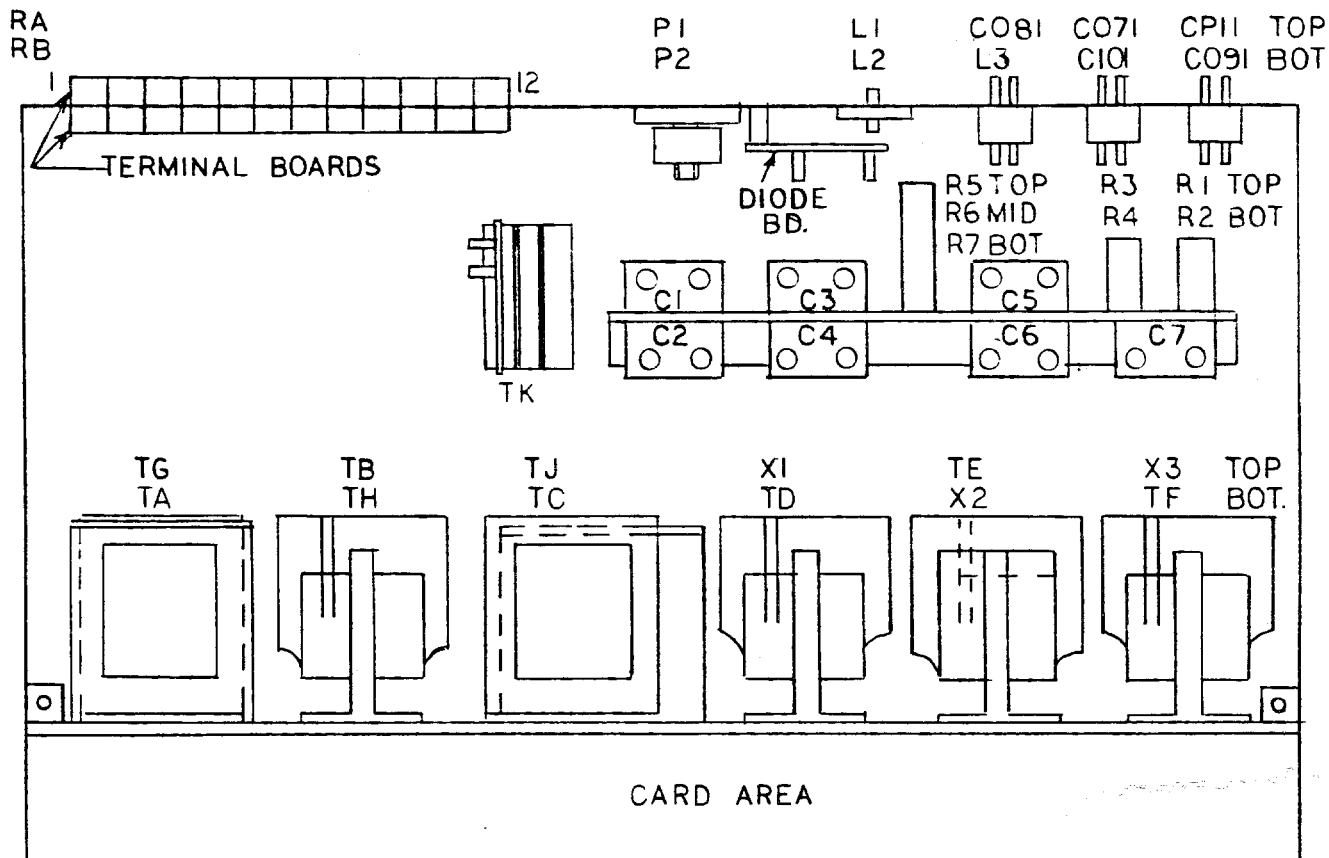
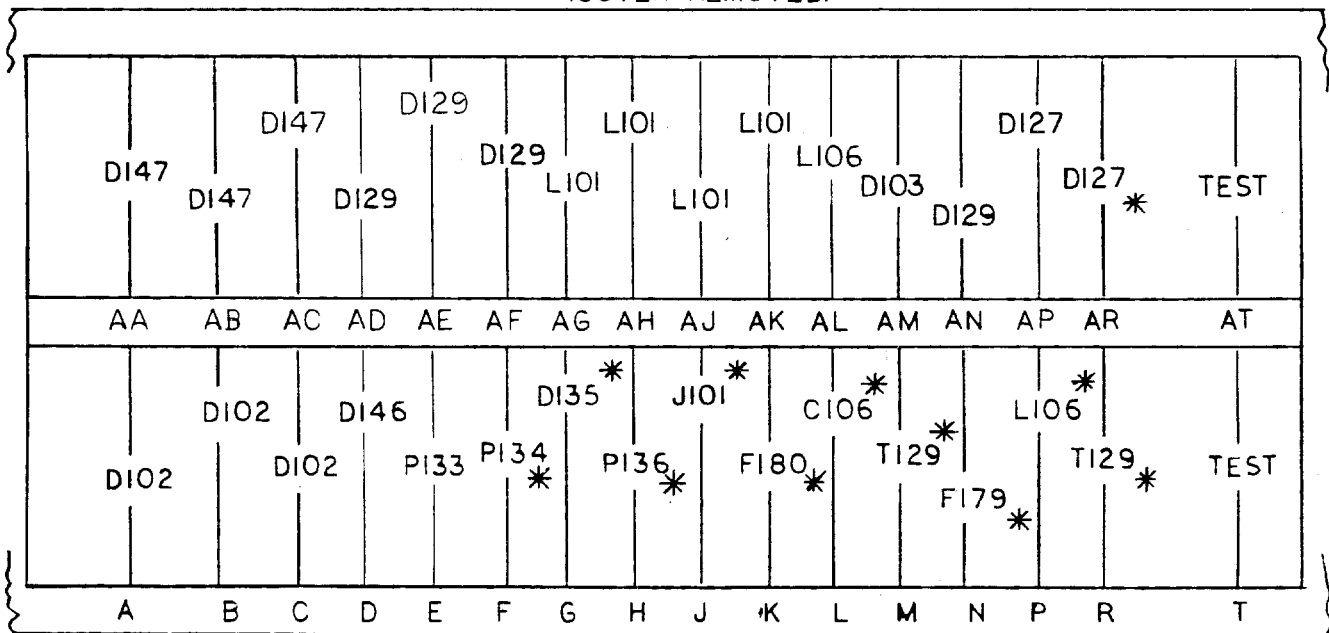

Figure 2 (0227A2047-0) Internal Connection Diagram Legend

GEK-65694



PLAN VIEW
(COVER REMOVED)



FRONT VIEW
(COVER REMOVED)

* OPTIONAL CARDS

Figure 4 (0285A6156-0) Component and Card Locations for the Type SLCV61A Relay

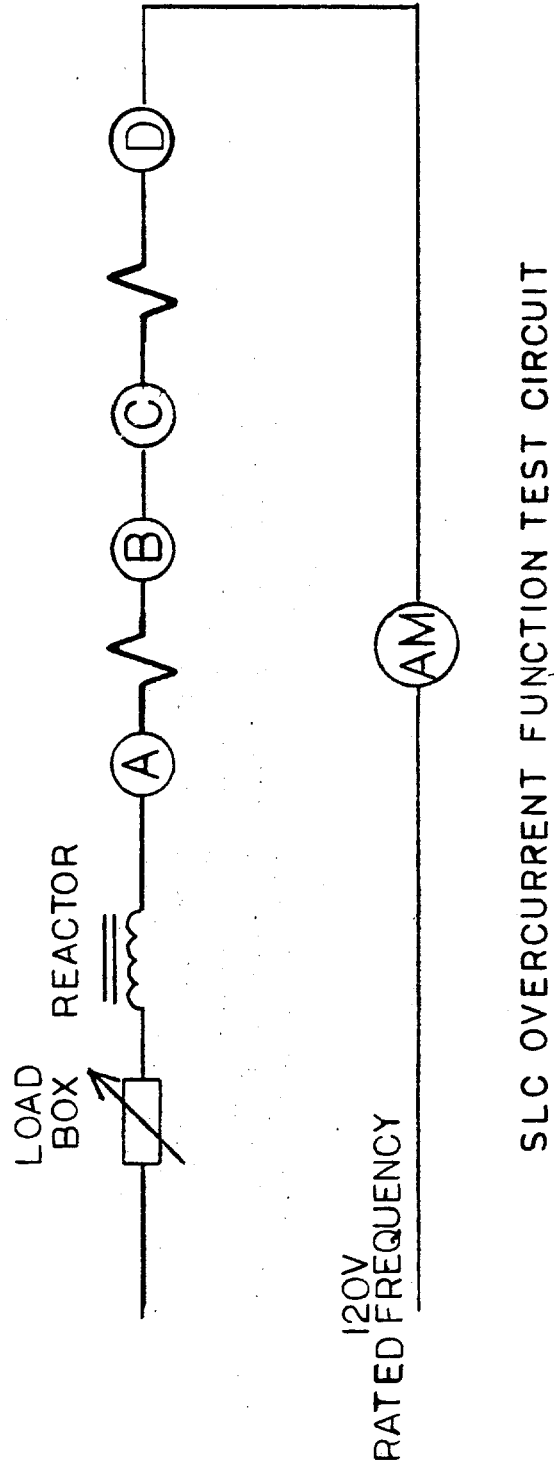
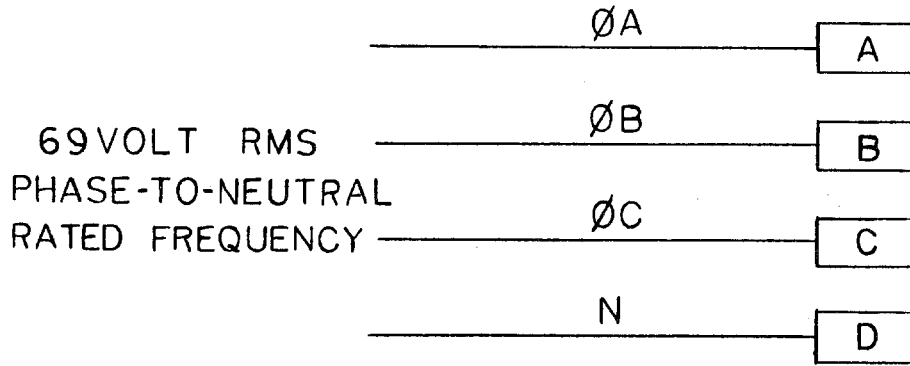

Figure 5 (0285A6182-0) Test Circuits for the Type SLCV61A Current Functions



THREE PHASE CONNECTION

TEST	CONNECTIONS				RELAY INPUT	OUTPUT TO REF. PI33CARD (POS. E)		ADJUST
	A	B	C	D		PIN 8	PIN 9	
#1 POS. SEQ.	RB2	RB4	RB6	* RB3	BALANCED 69V RMS Ø-N	APPROX. 4.25V RMS	LESS THAN 0.3V P-P RIPPLE	PI & P2 ALTERNATELY FOR MINIMUM FUNDAMENTAL OUTPUT AT PIN 9
#2 NEG. SEQ.	RB2	RB6	RB4	* RB3	BALANCED 69V RMS Ø-N	LESS THAN 0.2V P-P RIPPLE	APPROX. 8.0V RMS	—

* JUMPER RB3 TO RB5 & RB7

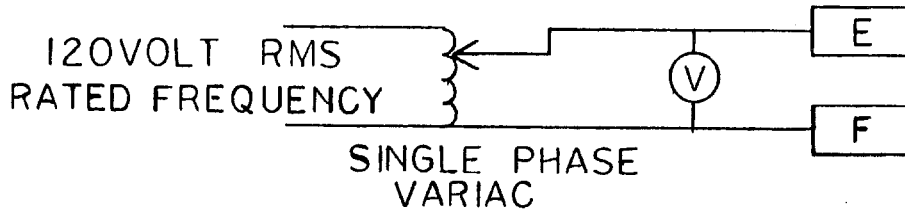

SINGLE PHASE CONNECTION

TEST	CONNECT.		RELAY INPUT	OUTPUT TO REF. PI33CARD (POS. E)	
	E	F		PIN 8	PIN 9
POS/NEG SEQ CHECK ØA	RB2 **	RB3 **	69V RMS	APPROX. 1.42V RMS	APPROX. 2.67V RMS

** FOR CHECK OF ØB CONNECT: E - RB4
 F - RB5
 FOR CHECK OF ØC CONNECT: E - RB6
 F - RB7

Figure 6 (0285A6647-0) Test Circuit for the Type SLCV61A Sequence Voltage Circuits

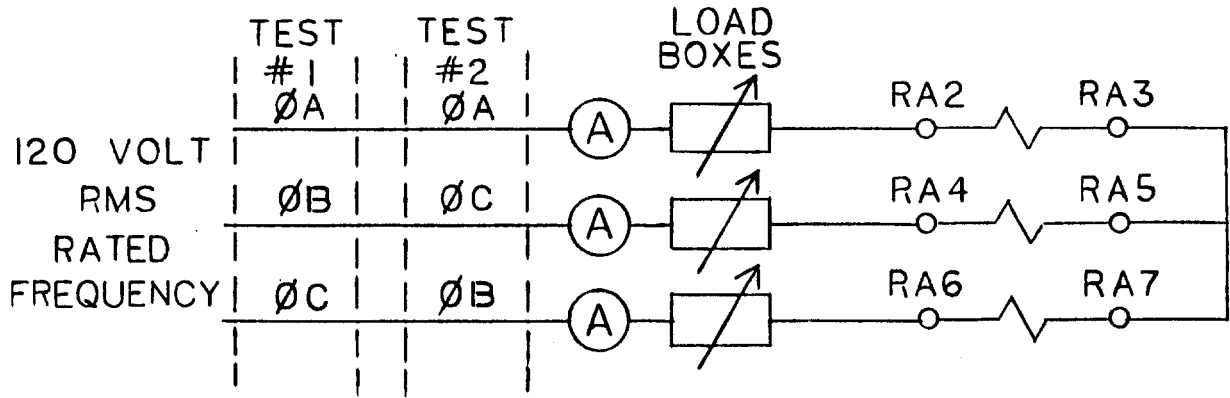

THREE PHASE CONNECTION

TEST	RELAY INPUT	OUTPUT TO REF. PI34CARD (POS.F)		
		PIN 7	PIN 8	PIN 9
#1 POS. SEQ. CHECK ØA	RELAY RATED CURRENT	APPROX. 1.4 V RMS	APPROX. 8.0 V RMS	LESS THAN 0.3V P-P RIPPLE
#2 NEG. SEQ. CHECK ØC	RELAY RATED CURRENT	LESS THAN 0.1V P-P RIPPLE	LESS THAN 0.6V P-P RIPPLE	APPROX. 3.2V RMS

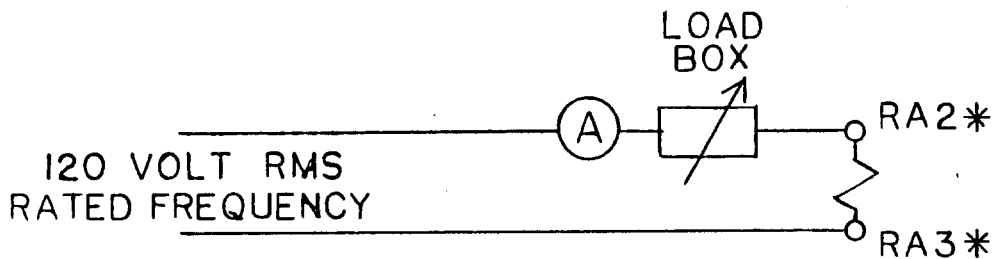

SINGLE PHASE CONNECTION

TEST	RELAY INPUT	OUTPUT TO REF. PI34CARD (POS.F)		
		PIN 7	PIN 8	PIN 9
POS/NEG SEQ CHECK ØA	5A RMS	APPROX. 0.5 V RMS	APPROX. 2.7 V RMS	APPROX. 1.1 V RMS

* FOR CHECK OF ØB CONNECT: RA4 & RA5.
 * FOR CHECK OF ØC CONNECT: RA6 & RA7.

Figure 7 (0285A6648-0) Test Circuit for the Type SLCV61A Sequence Current Circuits

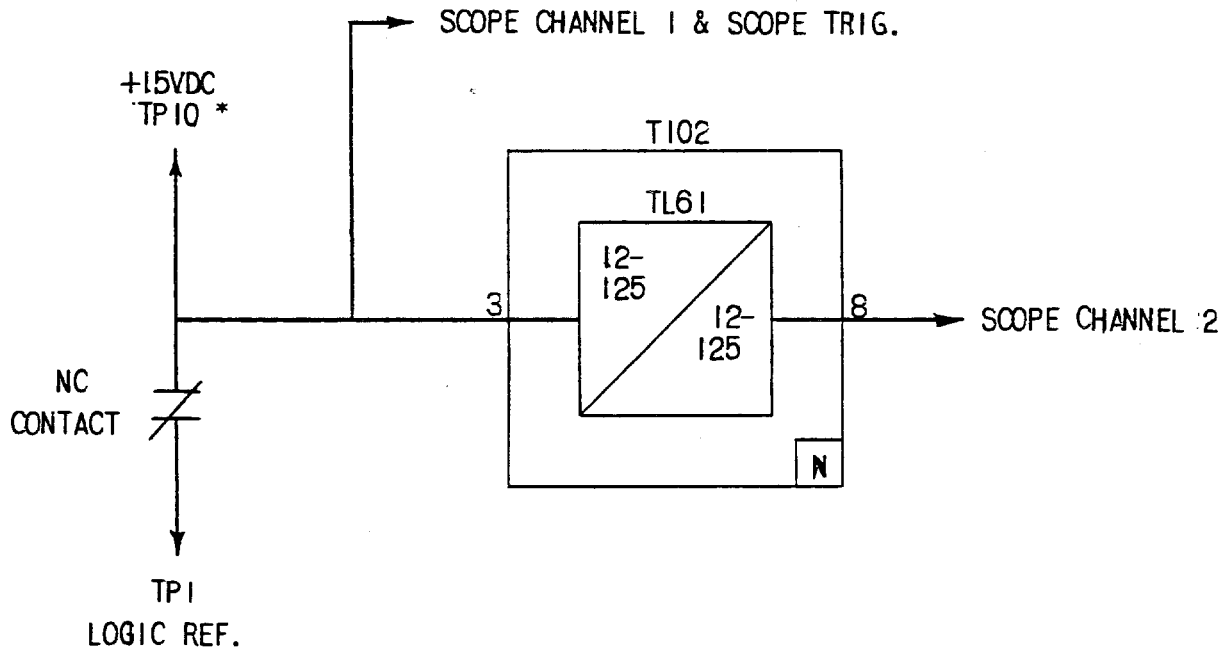

* THE 15VDC SIGNAL AT PIN 10 HAS A CURRENT LIMITING RESISTOR MOUNTED ON THE TEST CARD.

Figure 8 (0246A7987-0) Timer Test Circuit

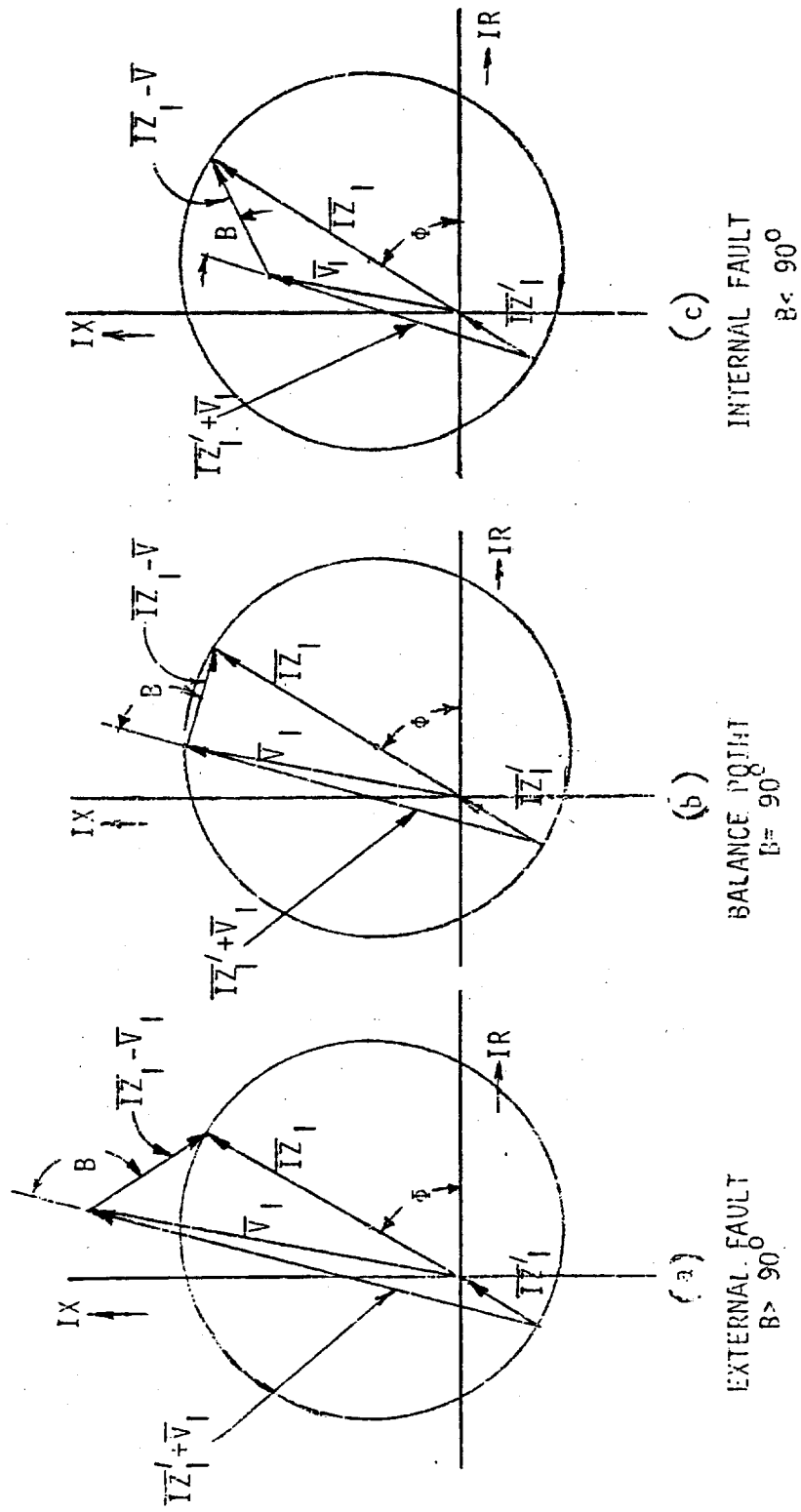

ϕ = ANGLE OF MAX. REACH

Figure 9 (0246A7984-0) Offset Mho Characteristic by Phase Angle Measurement

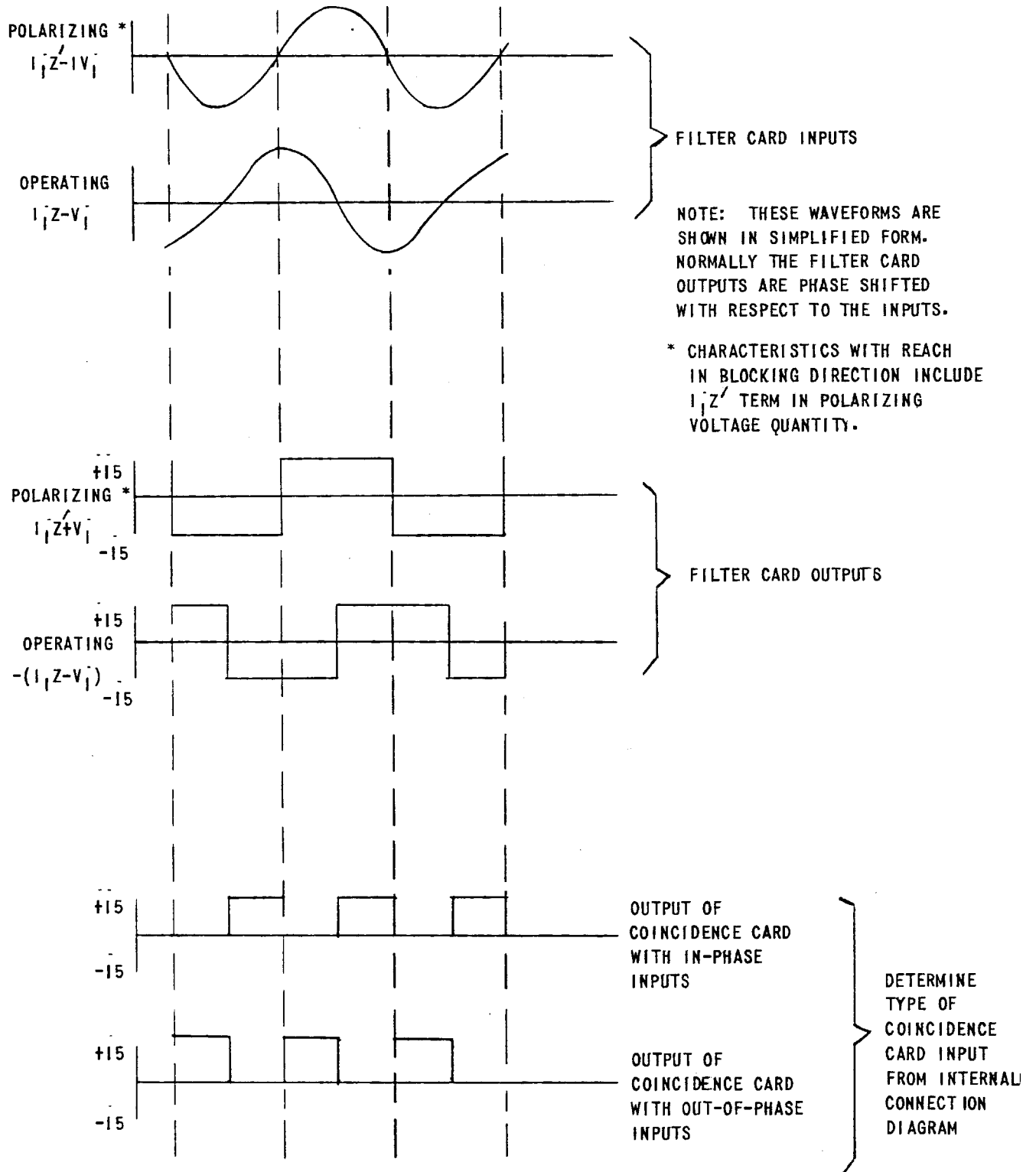
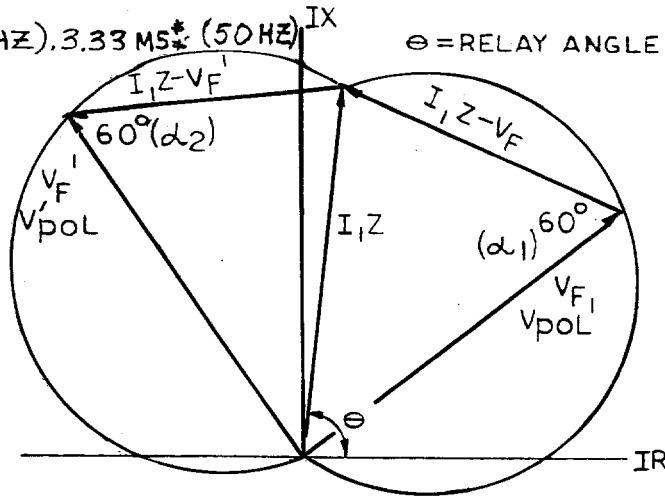

Figure 10 (0257A6209-0) M₁B Operating Quantity Wave Forms

TIMER SETTING = 2.76ms (60 HZ), 3.33ms* (50 HZ) $\theta = \text{RELAY ANGLE}$

A. $V_{POL} \& V_F$ IN PHASE
 $\alpha_1 = \text{TIMER SETTING} = 60^\circ$
 $\alpha_2 = \text{TIMER SETTING} = 60^\circ$
 $\phi = 0^\circ$



B. V_{POL} LEADS V_F BY 15°
 $\phi = 15^\circ$
 $\alpha_1 = \text{TIMER SETTING} - \phi = 60^\circ - 15^\circ = 45^\circ$
 $\alpha_2 = \text{TIMER SETTING} + \phi = 60^\circ + 15^\circ = 75^\circ$

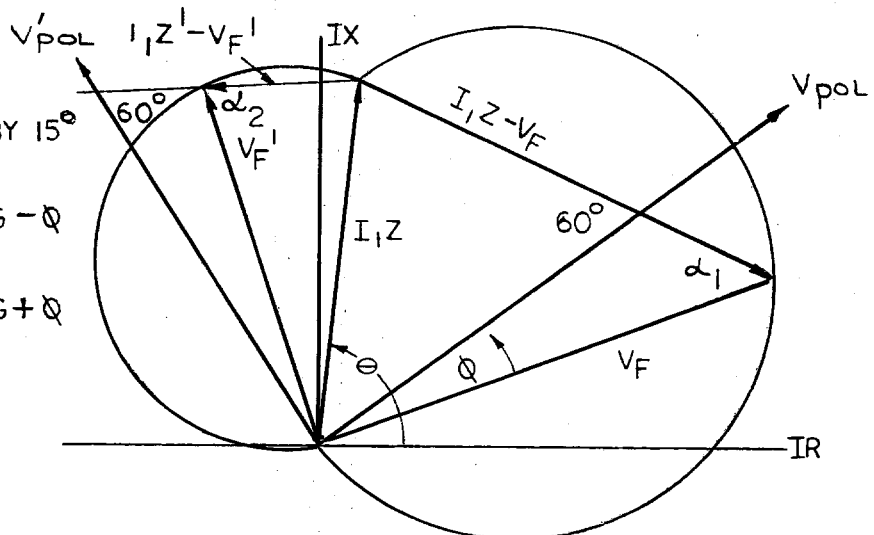

C. V_{POL} LAGS V_F BY 15°
 $\phi = -15^\circ$
 $\alpha_1 = 60 - (-15^\circ) = 75^\circ$
 $\alpha_2 = 60 - 15^\circ = 45^\circ$

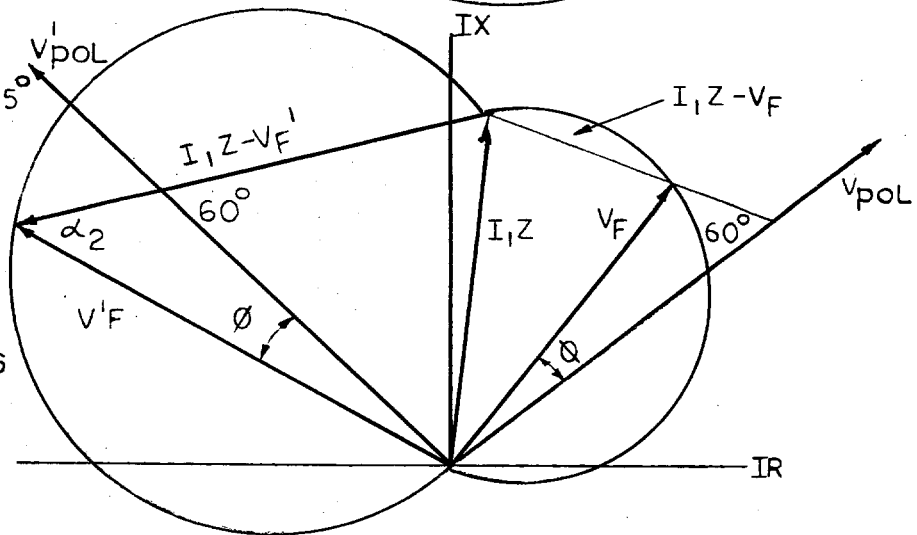

* 50 HZ 1 AMP MODELS

Figure 11 (0246A6866-0) Effect of Polarizing Phase Shift on an Mho Characteristic

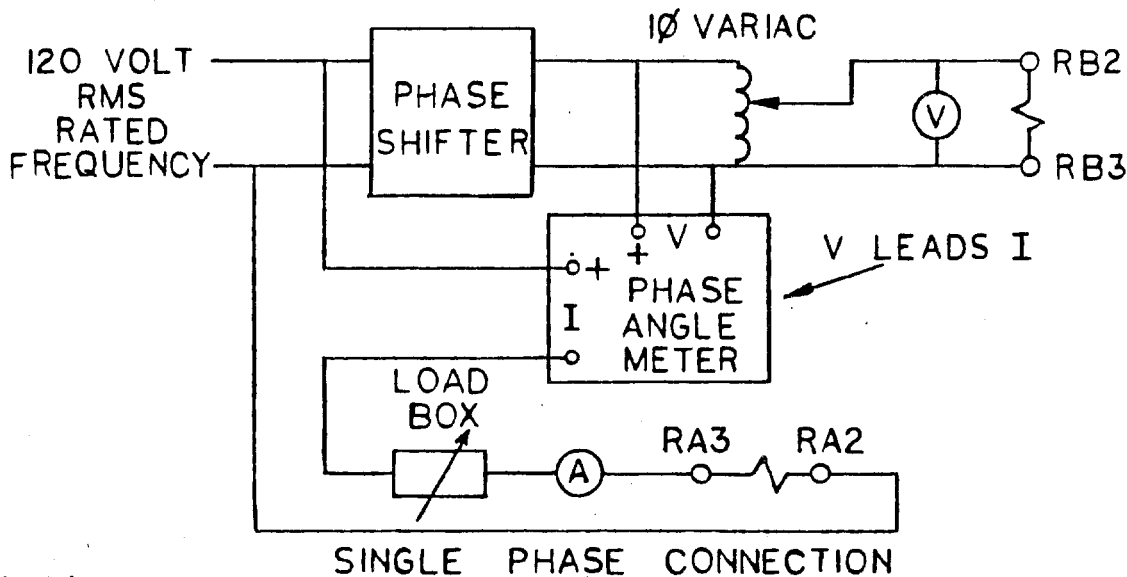
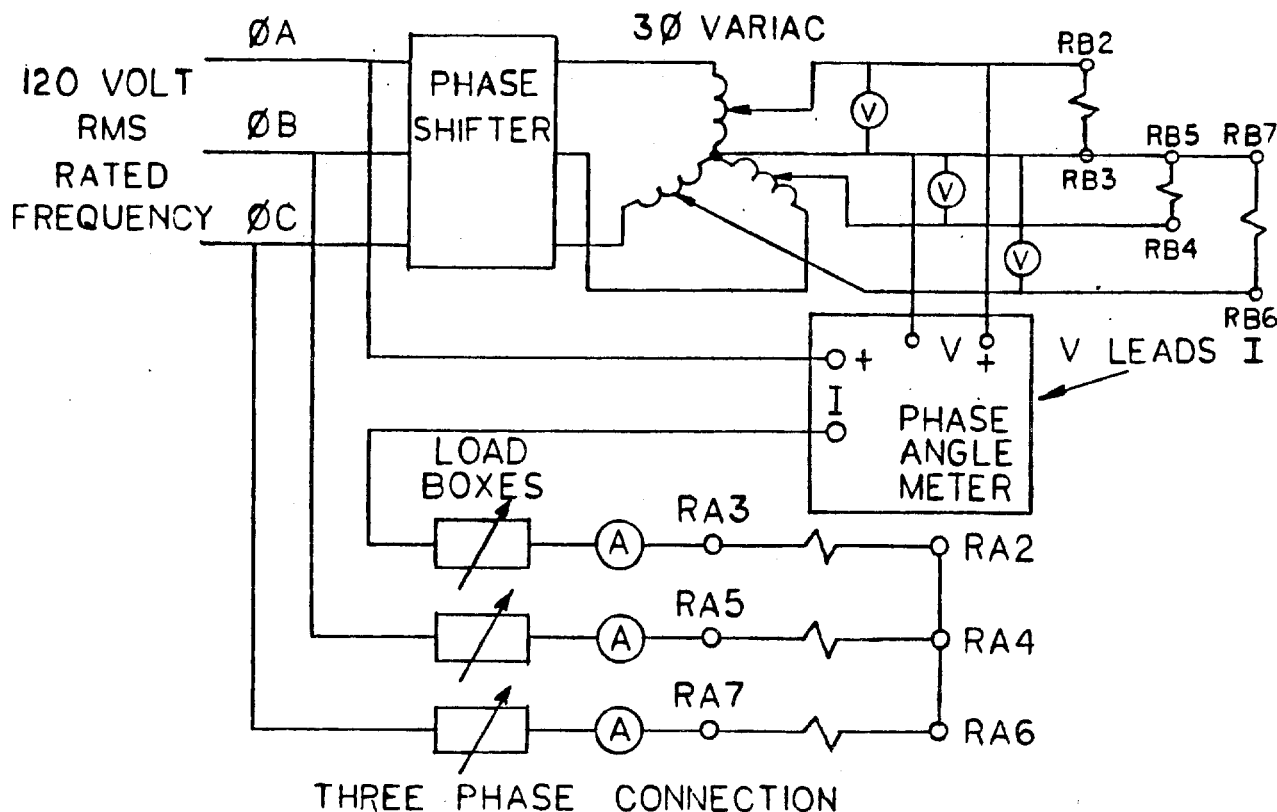

TEST	RELAY INPUT			OUTPUT-TO-REF. AT TEST POINT TP7	ADJUSTMENTS
	AMPS	VOLTS	Ø ANGLE METER		
M ₁ B PICKUP	RELAY RATED CURRENT	M ₁ B PICKUP PER EQ. 1, 2, 3, OR 4	ANGLE OF INTEREST (γ)	TP7 GOES FROM REF. TO +15VDC WHEN M ₁ B PICKS UP	MAKE ADJUSTMENTS PER "TESTING PROCEDURES" SECTION ON M ₁ B UNIT

Figure 12 (0285A6649-0) Test Circuit for M₁B Unit of the SLCV61A Relay

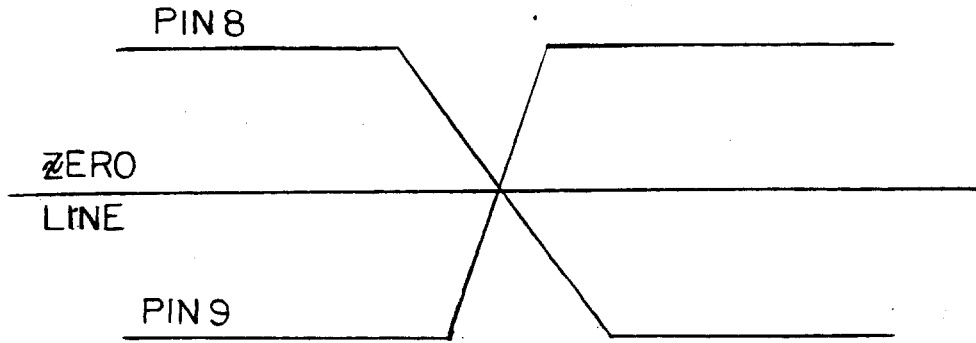

PROPERLY SET 0 DEGREE PHASE SHIFT

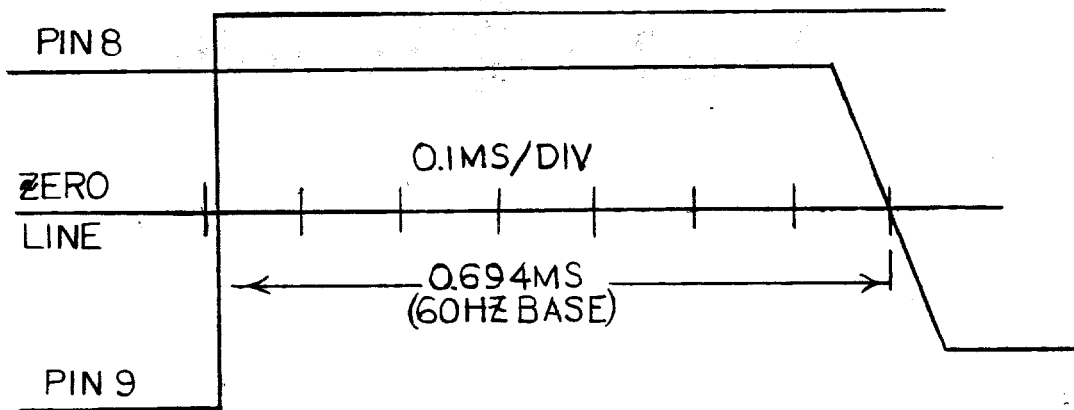

PROPERLY SET 15 DEGREE PHASE SHIFT

Figure 13 (0257A9696-1) Polarizing Circuit Phase Shift Waveforms

**GENERAL ELECTRIC COMPANY
POWER SYSTEMS MANAGEMENT BUSINESS DEPT.
MALVERN, PA 19355**

GENERAL  ELECTRIC