



INSTRUCTIONS

GEK-45371

STATIC THREE PHASE FIRST ZONE DIRECTIONAL

MHO DISTANCE RELAY

TYPE SLY52A

POWER SYSTEMS MANAGEMENT DEPARTMENT

GENERAL  ELECTRIC

PHILADELPHIA, PA.

C O N T E N T S

DESCRIPTION.....3

APPLICATION.....3

 STEP DISTANCE SCHEMES.....3

 PERMISSIVE UNDERREACHING TRANSFERRED TRIPPING PROTECTION...4

 THREE TERMINAL LINES.....4

RANGES.....4

RATINGS.....4

BURDENS.....5

 D-C BURDEN.....5

 A-C BURDEN.....5

OPERATING PRINCIPLES & CHARACTERISTICS.....5

 M1 TRIPPING FUNCTION.....5

CIRCUIT DESCRIPTION.....6

CALCULATION OF SETTINGS.....6

CONSTRUCTION.....7

RECEIVING, HANDLING & STORAGE.....8

INSTALLATION TESTS.....8

GENERAL TESTING INSTRUCTIONS.....8

 INPUT CIRCUITS.....8

 OUTPUT SIGNALS.....8

DETAILED TESTING INSTRUCTIONS.....9

 CAUTION.....9

 BASIC MINIMUM OHMIC TAP SETTING.....9

 VOLTAGE RESTRAINT TAP SETTING.....9

 ANGLE OF MAXIMUM REACH.....9

 TIMER CARD ADJUSTMENTS & TEST.....9

 T133.....10

 TESTING MHO CHARACTERISTIC.....11

 ANGLE OF MAXIMUM REACH CHECK.....12

PERIODIC CHECKS & ROUTINE MAINTENANCE.....12

 PERIODIC TESTS.....12

 TROUBLE SHOOTING.....13

 SPARE PARTS.....13

DESCRIPTION

The Type SLY52A relay is a static, three-phase, directional mho distance relay intended for use as the first zone of protection against multi-phase faults on transmission lines. The relay is packaged in a two rack unit case as illustrated in Figure 1. Component locations are shown in Figure 2.

The SLY52A relay is not intended for use by itself but rather as a part of a complement of equipment to form a protective relaying scheme. The static circuits in the SLY52A require a +15 volt d-c source which is provided by a Type SSA50 power supply. Various other phase and ground fault detecting relays may also be used in conjunction with the SLY52A depending on the protective scheme involved. In addition, a Type SLA logic relay and a Type SLAT output relay will be required. The outputs of the SLY52A relay are d-c logic signals that are fed into the SLA relay. The internal circuitry of which depends upon the specific overall protective scheme. The internal connections of the SLY52A relay are shown in Figure 3.

For a complete description of the overall scheme in which this relay is employed refer to the overall logic diagram and its associated logic description that is supplied with each terminal of equipment.

Note: The Type SLY52A relay is suitable for use with potential transformers, or with coupling capacitor voltage transformers having a transient response equivalent to or better than the General Electric Type CD31 device.

APPLICATION

The Type SLY52A relay is a static, three-phase directional mho distance relay for transmission line protection. Since the transient overreach of the mho functions is limited by design, the relay is suitable for use as the direct tripping first zone function in a step distance scheme, or as the phase underreaching functions in a permissive underreaching transferred tripping scheme to initiate transmission of the permissive signal.

The SLY52A relay is suitable for application with potential transformers or with coupling capacitor voltage transformers having a transient response equivalent to or better than the General Electric Company's Type CD31 device. The curve in Figure 4 shows the average operating time versus fault location for an SLY52A M1 function when applied with a Type CD31 coupling capacitor voltage transformer. The time curve is based on a typical application on a 500 kv line 75 miles in length with a source impedance equivalent to 25 miles of 500 kv line, using 2000/5 CT's, and with the M1 function set to reach 90% of the protected line. It will be noted that the best operating time of this relay can be expected for faults up to 50% of the reach setting. For faults beyond this point the operating time tends to increase. For installations where potential transformers, or CCVT's having a transient response equal to or better than that of the GE Type CD51, are available faster operating times for faults beyond the 50% reach setting may be obtained with the Type SLY52B relay.

STEP DISTANCE SCHEMES

The limited transient overreach characteristic of the SLY52A relay makes it well suited for application as the zone-1 unit (M1) in a step distance scheme. In such applications a reach setting of up to 90% of the protected line is recommended.

The M1 function in the SLY52A relay has an angle of maximum reach which can be set for either 60 or 75 degrees lag by means of a jumper setting on the associated filter card. The 60 degree angle will accommodate more arc resistance and hence is useful on lower voltage transmission lines with less lagging angles where arc resistance may be a problem. The 75 degree angle is most useful for the extra high voltage lines having highly lagging angles or on longer lines, where arc resistance is of less importance.

These instructions do not purport to cover all details or variations in equipment nor to provide for every possible contingency to be met in connection with installation, operation or maintenance. Should further information be desired or should particular problems arise which are not covered sufficiently for the purchaser's purposes, the matter should be referred to the General Electric Company.

The sensitivity of the M1 function is measured by the relation between the three phase fault and the reduction of ohmic reach of the function as the current decreases. The sensitivity is defined as the minimum three phase fault current for a particular base reach (minimum ohm) tap which will cause the relay reach to be reduced to 90% of the nominal set reach. The sensitivity of the various M1 base reach taps are as follows:

BASE REACH TAP	MINIMUM 3-PHASE CURRENT
.3	(LATER)
.6	
.75	
1.2	
1.5	
3.0	

Refer to the "CALCULATION OF SETTINGS" section of this book for details of setting calculations and a typical example.

PERMISSIVE UNDERREACHING TRANSFERRED TRIPPING PROTECTION

In this type of pilot relaying scheme M1 is the underreaching function, and is connected to trip the local breaker directly and key the channel to send a permissive trip signal to the remote line terminal. The operation of an associated overreaching (M2) fault detector at the remote terminal and the receipt of this permissive trip signal will trip the remote line terminal breaker. Since the M1 functions are applied to trip directly they are normally set to reach to 90% of the protected line section.

THREE TERMINAL LINES

The SLY52A may be applied on three terminal lines, but it must be set so as to insure that the M1 function does not operate for any external faults. Therefore, the M1 setting at a given line terminal must not exceed 90% of the distance to the nearest remote line terminal with the breaker at the other remote terminal open.

An additional consideration for permissive underreaching transferred tripping applications is the need to set the M1 functions at all three terminals long enough to overlap each other, so that any fault on the protected line section will be detected by the M1 at one or more line terminals. If these M1 zones do not overlap, a fault could occur in the resulting dead zone and no transferred tripping could be accomplished at any line terminal.

RANGES

The basic ohmic taps provided in the SLY52A are 0.3, 0.6, 0.75, 1.2, 1.5, and 3.0. These values are calibrated at the factory with the angle of maximum reach set at 75°. If the 60° angle of maximum reach is chosen the basic ohmic taps can be recalibrated to the above values using the procedure outlined in the Detailed Testing Section of this book under the Testing The MHO Characteristic heading. If it is decided not to recalibrate, the basic ohmic tap values will be 3.4% greater at the 60° setting, i.e., 0.31, 0.62, 0.775, 1.24, 1.55, and 3.1 ohms.

RATINGS

The Type SLY52A relay is designed for use in an environment where the air temperature outside the relay case is between -20°C and +65°C.

The Type SLY52A relay requires a +15VDC power source which can be obtained from power supplies Type SSA50 and up.

The current circuits of the Type SLY52A relay are rated at 5 amperes, 60 hertz, for continuous duty and have a one-second rating of 300 amperes. The potential circuits are rated 120 volts, 60 hertz.

BURDENSD-C BURDEN

The Type SLY52A relay presents a maximum burden to the Type SSA power supply of:

350 ma from the +15VDC supply

50 ma from the -15VDC supply

A-C BURDEN

Potential circuits at 120 V $\emptyset - \emptyset$ maximum

0.30 volt-amp

0.24 watts

0.18 vars

Current circuits at 5A $\emptyset - \emptyset$ maximum

Z = 0.017 $\angle 40^\circ$

R = 0.013

X = 0.011

OPERATING PRINCIPLES AND CHARACTERISTICS

The mho characteristic for the SLY52A relay is shown in Figure 5. All measurements are made on a phase-to-phase basis. V_a-V_b is compared with I_a-I_b in order to obtain the same relay reach for a phase-to-phase, a three-phase and a double phase-to-ground fault. The principle used to derive the characteristic is illustrated in Figure 6. The axes are "IR" and "IX". The \overline{IZ} quantity is a voltage proportional to the line current obtained by passing the line current through a network consisting of a current transformer and a reactor. The setting of this quantity establishes the "Base Reach" of the relay. The \overline{V} quantity is line voltage at the relay location, equal to IZ_F , where Z_F is the line impedance out to the fault. Comparison is between the polarizing voltage \overline{V} and the operating quantity $(\overline{IZ}-\overline{V})$. The angle B between these two quantities is greater than 90° for faults external to the relay characteristic, and is less than 90° for faults internal to the relay characteristic. For faults which cause \overline{V} to terminate on the relay characteristic the angle B is equal to 90° . This is true for any angular location of \overline{V} , because \overline{V} , \overline{IZ} , and $(\overline{IZ}-\overline{V})$ form a right triangle for any point on the relay characteristic.

The quantities \overline{V} and $(\overline{IZ}-\overline{V})$ are derived from the relay input quantities and are converted into +15 VDC to -15 VDC square waves in the F125 cards. These square waves have the same phase relationship as the AC quantities \overline{V} and $(\overline{IZ}-\overline{V})$. The square waves representing \overline{V} and $(\overline{IZ}-\overline{V})$ are compared on the C104 card. The output of the C104 card is a +15 VDC block equal to the duration of the coincidence of the \overline{V} and $(\overline{IZ}-\overline{V})$ square waves. Blocks which are 90° apart are coincident for 4.16 ms. Blocks which are less than 90° apart are coincident for more than 4.16 ms. This is illustrated in Figure 7.

M1 TRIPPING FUNCTION

The M1 function has a directional characteristic with the mho circle passing through the origin on an R-X diagram. See Figure 5.

If the 100% voltage tap is used, the phase-to-neutral reach of the relay at the angle \emptyset is equal to the \overline{IZ} base reach tap chosen. If a voltage tap other than 100% is chosen, relay reach is increased to inverse proportion to the voltage tap. For example, if the 50% voltage tap is used, relay operation still occurs for the same voltage applied to the measuring circuit, but since the actual line voltage is twice this amount, the relay reach is twice as great. The resulting mho circle has twice the reach, at any fault angle, and still passes through the origin.

Relay reach for the M1 unit at the angle of maximum reach \emptyset , may be calculated from the expression:

$$Z_{\max} = \frac{T_B}{T} \times 100 \text{ (at angle } \emptyset \text{)}$$

where T is the restraint tap setting expressed in % and $Z_0 = Z_{\max} \cos (\theta - \emptyset)$. Z_0 is the impedance the relay will be at any angle θ . T_B is the basic ohmic tap.

θ = Line angle

\emptyset = Relay maximum reach angle

The angle of maximum reach (\emptyset) can be adjusted by changing the position of plus 'X' on the F125 board. When points 1 and 2 and 3 and 4 are jumpered, the angle of maximum reach is equal to 60°; when points 2 and 3 and 4 and 5 are jumpered, the angle of maximum reach is equal to 75°.

To set the relay for the desired reach, it is necessary to first select the proper "Base Reach Tap". This tap should be the highest "Base Reach Tap" that is smaller than the desired ohmic reach. The setting of the "Base Reach Tap" is explained under the section titled "Construction" in this book. After the "Base Reach Tap" is selected the "Percent Restraint Tap" may now be chosen to produce the required relay reach.

CIRCUIT DESCRIPTION

The internal connections of the SLY52A relay are shown in Figure 3. The points on the left designated YA2, YA3, and YA4 are the voltage inputs. The points at the lower left designated YB1 through YB12 are the current inputs.

The relay input voltage is passed through a transformer which produces the polarizing voltage. This voltage is fed directly to the filter card. The other input to the filter card is (IZ-V). The IZ component comes from the input current passing through a current transformer and the secondary current being passed through a reactor to form the IZ quantity. The V portion comes directly from the tapped potential transformer.

The block-block method is used for the M1 function. Blocks are formed from the (IZ-V) quantity and the polarizing voltage by means of the filter card. These blocks are then fed to the coincidence logic card where the blocks are compared on a time basis. The coincidence card will produce output blocks only when both inputs are coincident (the same polarity). The output blocks of the coincidence logic card are then fed to the 4/5 timer card. The characteristic of the 4/5 timer is to produce no output until the input blocks are longer in duration than 4.16 milliseconds or 90°. If the timer is set to pick-up at some angle other than 90°, the resulting mho unit characteristic will not be a circle. Figure 8 shows the characteristic obtained for a timer setting of 3.0 milliseconds at an angle of maximum reach of 75°. Figure 8 shows the same characteristic at an angle of maximum reach of 60°. Figure 10 shows the characteristic for a timer setting of 6 milliseconds at an angle of maximum reach of 75°. Figure 11 shows the same characteristic at an angle of maximum reach of 60°. In general, the reach for a timer setting less than 90° is greater than the reach for a timer setting of 90° at the same fault angle. A timer setting of greater than 90° will give a reach less than the reach for a timer setting of 90°, again at the same fault angle.

CALCULATION OF SETTINGS

The following settings must be made on the SLY52A relay:

M1 angle of maximum reach (\emptyset)

M1 base reach (minimum ohms) tap (T_B)

M1 percent restraint tap setting (T)

In order to illustrate the setting calculations required, assume a transmission line with the following characteristics:

$$Z_1' = 32 \angle 85^\circ \text{ primary ohms, positive sequence impedance}$$

$$\text{CT Ratio} = 2,000/5$$

$$\text{PT Ratio} = 3,000/1$$

$$Z_1' \text{ Secondary} = Z_1' \text{ Primary} \times \frac{\text{CT Ratio}}{\text{PT Ratio}}$$

$$Z_1' \text{ Secondary} = 4.26 \angle 85^\circ \text{ ohms}$$

The choice of M1 angle of maximum reach (θ) depends on the line length and amount of arc resistance expected. The 60° angle will accommodate more arc resistance than the 75° angle. For these calculations assume the 60° angle of maximum reach is chosen.

For optimum performance, the highest value base reach tap (T_B) should be selected. Therefore, for this line with 4.26 ohm secondary impedance use the 3 ohm T_B base reach tap (which is 3.1 at 60° if not recalibrated see the "Ranges" section of this book).

The restraint tap setting (T) is determined by the following formula:

$$T = \frac{100 (T_B) \cos (\theta - \phi)}{0.9 (Z_1' \text{ secondary})}$$

- where:
- T_B = Relay basic minimum ohmic tap at the set angle of maximum reach
 - ϕ = Relay angle of maximum reach
 - Z_1' = Positive sequence phase-to-neutral impedance of the protected line from the relay to the remote terminal.
 - θ = Angle of Z_1' (line angle)

Substitution of the assumed values in the above equation yields a restraint tap setting (T) of 73%. If the 75° angling maximum reach setting had been selected the calculation would be the same except that T_B would be 3 ohms.

CONSTRUCTION

The Type SLY52A relay is packaged in a metal enclosure designed for mounting on a 19 inch rack. The relay is 2 rack units high (one rack unit is 1 3/4 inches). The relay contains the magnetics and tap blocks for setting the base reach and the percent restraint. It also contains the printed circuit cards for protecting all three phases of a power system. The relay has a hinged front cover and a removable top cover.

The tap block portion of the Type SLY52A relay is located at the left of the unit. Figure 12 shows the setting of one phase pair. The tap block is divided into two sections, percent restraint and base reach. These sections are identified at the top.

To set the percent restraint simply put the top M1 lead in the desired 10% hole and the bottom MT lead in the desired 1% hole. The setting for 74% restraint is shown in Figure 12.

To set the base reach simply put the extreme right hand M1 lead in either the 1.2K or the 3K hole. K is a ratio factor and is either 1, 1/2 or 1/4. K is determined by the terminals that are selected for current input on the YB terminal block at the back of the relay. The setting for a base reach of 1.2K is shown in Figure 12.

The base reach and percent restraint settings are made by jumpers with taper tip pins on the end. Two special tools have been supplied for these pins. One is an insertion tool and the other is an extraction tool. In order to get a proper connections and not cause any damage to the pins it is important that these tools be used.

The printed circuit cards are located to the right of the tap blocks. The printed circuit cards are identified by a code number such as F125, C104, or T133 where F designates filter, C designates coincidence, and T designates time delay. The printed circuit card locations are identified by letter designations or "addresses" (D, E, F, etc.) which appear on the guide strips in front of each socket, on the component location diagram, on the internal connection diagram, and on the printed circuit card itself. The test points (TP1, TP2, etc.) shown on the internal connection diagram are connected to instrument jacks on a test card in position T with TP1 located at the top of the card. TP1 is connected to relay reference, TP2 is connected to the -15 VDC bus, and TP10 is connected to the +15 VDC bus. The other seven test points are located at selected points in the logic circuitry to permit test measurement of the outputs of the functions and to facilitate signal tracing when trouble shooting.

RECEIVING, HANDLING AND STORAGE

This relay will normally be supplied as a part of a static relay equipment, mounted in a rack or cabinet with other static relays and test equipment. Immediately upon receipt of a static relay equipment it should be unpacked and examined for any damage sustained in transit. If injury or damage resulting from rough handling is evident, file a damage claim at once with the transportation company and promptly notify the nearest General Electric Sales Office.

Reasonable care should be exercised in unpacking the equipment. If the equipment is not to be installed immediately, it should be stored indoors in a location that is free from moisture, dust, metallic chips, and severe atmospheric contaminants.

Just prior to final installation the shipping support bolt should be removed from each side of all relay units, to facilitate possible future unit removal for maintenance. These shipping support bolts are approximately 8 inches back from the relay unit front panel. **WARNING - STATIC RELAY EQUIPMENT, WHEN SUPPLIED IN SWING RACK CABINETS, SHOULD BE SECURELY ANCHORED TO THE FLOOR OR TO THE SHIPPING PALLET TO PREVENT THE EQUIPMENT FROM TIPPING OVER WHEN THE SWING RACK IS OPENED.**

The Type SLY52A relay contains printed circuit cards with trimmer potentiometers mounted on them. Some of these trimmer potentiometers are calibrated at the factory and sealed. These potentiometers should not be adjusted by the user.

INSTALLATION TESTS

The Type SLY52A relay is usually supplied from the factory mounted and wired in a static relay equipment. All units in a given equipment have been calibrated together at the factory and will have the same summary number on the unit nameplate.

The following checks and adjustments should be made by the user in accordance with the procedures given below under DETAILED TESTING INSTRUCTIONS, before the relays are put in service. Some of the following items are checks of factory calibrations and settings, or installation connections and hence do not normally require readjustment in the field. Other items cover settings or adjustments which depend on installation conditions and hence must be made on the installed equipment.

1. M1 base reach taps
2. M1 reach by voltage tap setting
3. The angle of maximum reach
4. M1 characteristic timer settings

GENERAL TESTING INSTRUCTIONS

INPUT CIRCUITS

The Type SLY52A relay has two terminal blocks on the rear of the unit identified as YA and YB. Both these terminal blocks are wired through the test panel in a static relay equipment where input current and voltages can be supplied through the standard Type XLA test plug. When other test facilities are used, input currents and voltages should be applied to test points which connect to the same YA and YB terminal points as those shown on the test circuit diagram.

When the Type SLY52A relay is furnished in a static relay equipment, reference to the job elementary will provide information concerning customer relay inputs.

OUTPUT SIGNALS

Output signals are measured with respect to the reference bus or TP1. Outputs are continuous signals of approximately +12 to +15 volts for the "ON" condition and 0 volts for the "OFF" condition. This output can be monitored with an oscilloscope, a portable high impedance d-c voltmeter, or with the test panel voltmeter if available. To connect the test panel voltmeter, place the test lead in the proper test point pin jack and the other end in the pin jack on the test panel.

DETAILED TESTING INSTRUCTIONSCAUTION

THE LOGIC SYSTEM SIDE OF THE DC POWER SUPPLY USED WITH MOD III STATIC RELAY EQUIPMENT IS ISOLATED FROM GROUND. IT IS A DESIGN CHARACTERISTIC OF MOST ELECTRONIC INSTRUMENTS THAT ONE OF THE SIGNAL INPUT TERMINALS IS CONNECTED TO INSTRUMENT CHASSIS. IF THE INSTRUMENT USED TO TEST THE RELAY EQUIPMENT IS ISOLATED FROM GROUND, ITS CHASSIS MAY HAVE AN ELECTRICAL POTENTIAL WITH RESPECT TO GROUND. THE USE OF A TEST INSTRUMENT WITH A GROUNDED CHASSIS WILL NOT AFFECT THE TESTING OF THE EQUIPMENT. HOWEVER, A SECOND GROUND CONNECTION TO THE EQUIPMENT, SUCH AS A TEST LEAD INADVERTENTLY DROPPING AGAINST THE RELAY CASE MAY CAUSE DAMAGE TO THE LOGIC CIRCUITRY. NO EXTERNAL TEST EQUIPMENT SHOULD BE LEFT CONNECTED TO THE STATIC RELAYS WHEN THEY ARE IN PROTECTIVE SERVICE, SINCE TEST EQUIPMENT GROUNDING REDUCES THE EFFECTIVENESS OF THE ISOLATION PROVIDED.

BASIC MINIMUM OHMIC TAP SETTING

The selection of the basic minimum ohmic tap is discussed in the section "CALCULATION OF SETTINGS". The setting of the basic minimum ohmic tap is described in the section "CONSTRUCTION".

VOLTAGE RESTRAINT TAP SETTING

The selection of the voltage restraint tap is discussed in the section "CALCULATION OF SETTINGS". The setting of the voltage restraint tap is described in the section "CONSTRUCTION".

The reach of the relay at the angle of maximum reach is given by the relationship

$$Z_{MAX} = \frac{T_B}{T} \times 100$$

where: Z_{MAX} is the reach at the angle of maximum reach

T_B is the basic minimum ohmic tap

T is the voltage restraint tap in percent.

ANGLE OF MAXIMUM REACH

The angle of maximum reach can be set at either 60° or 75° by means of a plug located on the F125 filter cards which are located in card positions G, K, and P in the SLY52A relay. The 75° angle of maximum reach is selected by locating plug X in positions OK 23-45. The 60° angle is set by locating plug X in position OK 12-34.

TIMER CARD ADJUSTMENTS AND TESTS

The pickup setting determines the amount of coincidence that must occur between the operate (IZ-V) and restraint (V) signals before a logic output occurs. The reset time delay (dropout time) of the timer provides an overlap between inputs from the coincidence logic which produces a continuous logic signal and in some cases provides an intentional time delay before resetting. The timer outputs are DC logic signals. The settings for the timers in a particular scheme can be found on the OVERALL LOGIC DIAGRAM for that scheme.

Note: The timers in the SLY52A relay have been adjusted at the factory. If during trouble shooting or periodic maintenance, a plot of the MHO characteristic indicates an incorrect timer setting (i.e. the characteristic is too wide or too narrow) the following procedure should be used. This procedure also applies to adjustment or replacement cards.

T133

The T133 timer affects the M1 characteristic shape. Three potentiometers are provided for adjustment purposes. P1 the first pickup is the top potentiometer. P2 which sets the dropout is the middle potentiometer and P3 (the steady state pickup) which determines the characteristic shape is on the bottom.

There are two procedures listed below to set the T133 timer. The first procedure is used if a touch-up of the characteristic shape is required. The second procedure is used when the card is replaced or when the card is suspected of being incorrectly adjusted.

Procedure 1

If a plot of the characteristic is too wide or too narrow indicating an incorrect steady state pickup setting, P3 can be adjusted to obtain the correct shape. However, do not change the settings of P1 or P2 during this procedure as they have no effect on the shape of the characteristic.

Procedure 2

Note all three potentiometers must be set in this procedure. Follow the setting order shown below to obtain correct operation of the card.

To set potentiometer P1 the first pickup;

- a. Remove the C104 card on the phase pair being tested.
- b. Connect the test circuit of Figure 13.
- c. Connect the input signal to the test point on the input of the timer being tested (TP3 for phase 1-2)
- d. Use an oscilloscope with a horizontal sweep which can be triggered externally. Connect the external trigger input to the test point on the input of the timer being tested and the vertical input to the test point on the output of the timer being tested.
- e. Set P3 fully counterclockwise.
- f. With the oscilloscope set for positive slope triggering, open the normally closed contact. The trace should step to +12 to +15 volts. Adjust P1 to obtain the pickup time specified on the Logic Diagram. Clockwise rotation will increase the pickup time delay.

To set potentiometer P2 the dropout time delay:

- a. thru (d) same as for P1.
- e. With the oscilloscope set for negative slope triggering, open the contact to allow the timer to pickup, then close the contact and the desired dropout time can be set. To increase the dropout time turn P2 clockwise.

To set potentiometer P3 the steady state pickup;

- a. Install the C104 card for the phase pair under test.
- b. Connect the AC test circuit of Figure 14.
- c. Set the current to 5 amperes.
- d. Set the voltage to 25 volts.
- e. Swing the phase shifter to the point that causes a square with an ON and OFF time, as measured with an oscilloscope, at the input of the timer being tested, which is the same as the pickup time to be set.
- f. Move the oscilloscope input to the output of the timer being tested and adjust P3 to the point that makes the card's output just become a continuous DC level of over 12 volts - DO NOT READJUST THE P1 and P2 POTENTIOMETERS.
- g. Plot the characteristic using the AC test circuit of Figure 14 and touch up the P3 setting to obtain characteristic shape desired.

TESTING MHO CHARACTERISTIC

The mho characteristic may be checked over its entire range by using the test circuit employing the phase shifter and phase angle meter shown in Figure 14. Input connections for testing any of the phase-pair characteristics should be made with Figure 14 and Table 1.

TABLE I

PHASE	CONNECT YA AND YB TERMINALS TO POINTS IDENTIFIED BY LETTERS						MHO OUTPUT
	A	B	C	D	E	F	
PHASE 1-2	YA2	YA3	YB1	YB4	YB8	YB5	TP6
PHASE 2-3	YA3	YA4	YB5	YB8	YB12	YB9	TP7
PHASE 3-1	YA4	YA2	YB9	YB12	YB4	YB1	TP8

By setting the current to 5 amperes (constant) the reach at any angle becomes a function of the settings of both the base reach and restraint taps. Rotating the phase shifter provides a means of checking the reach on any point of the characteristic. Notice that as the percent value of the restraint taps decrease the phase-to-phase impedance increases.

To obtain any points on the relay characteristic for any one of the three phases, observe the following procedure.

- a. Set up the test circuit of Figure 14 for the particular phase being tested. Make the AC connections according to Table 1.
- b. Set the test current to 5 amps RMS.
- c. Be sure that the current limiting reactor is as high as possible in ohmic value (perhaps 24 ohms). This assures the most harmonic-free current possible.
- d. Remove the coincidence cards (C104) of the phases not being tested. Jumper the test points at the outputs of these cards down to reference.
Example: When testing ϕ 1-2, remove the C104 cards in positions "L" and "R" and jumper TP4 and TP5 to reference.
- e. Connect the instrumentation (preferably an oscilloscope) between the mho output of the phase under test and reference at TP1.
- f. Set the phase angle meter at the specific angle of interest by rotating the phase shifter.
- g. Adjust the variac until the mho function output fully picks up. Note that the point just at the verge of pick-up, as read on Figure 14 voltmeter (V), defines the relay mho characteristic.

The voltage at which the relay picks up can be expressed by:

$$V_{\phi-\phi} = \frac{2I T_B \cos(\theta - \phi)}{T} \times 100$$

- where:
- T_B = basic minimum ohmic tap
 - T = voltage restraint tap in percent
 - I = 5 ampere test current
 - θ = angle between applied voltage and current
 - ϕ = angle of maximum reach

A plot of the mho characteristic can be obtained by varying the phase angle and repeating steps f and g. The pickup setting of the timer can be adjusted to obtain the desired characteristic shape.

The reach of the relay is calibrated at the factory for a 75° angle of maximum reach. If the relay is used at 60°, the reach should be readjusted. Using the test procedure outlined above, set $V_{\theta-\theta}$ for the desired pickup at the angle of maximum reach. Adjust P10 on the F125 card to obtain the pickup point of the function.

An alternate method of testing the relay characteristic is shown in Figure 15 where the R-X test combination is employed. The circuit uses the test box (102L201), test reactor (6054975) and test resistor (6158546) described at GEI-44236. Since a limited number of resistor-reactor fault impedances are available, only a few points on the relay characteristic can be checked.

ANGLE OF MAXIMUM REACH CHECK

As stated earlier the angle of maximum reach, θ , can be adjusted by changing the setting of plug X on the F125 printed circuit. The angle is typically factory adjusted to produce a 75° angle of maximum reach. In the Type SLY52A relay the angle of maximum reach can be adjusted to 60°. A check of the angle of maximum reach can be made by using the test circuit of Figure 14. The recommended procedure is as follows:

- a. Determine what test voltage V in Figure 14 is necessary to produce output at the relays maximum reach angle for 5 amperes of current, and the particular tap setting.

The voltage V at the angle of maximum reach is:

$$V = \frac{2 I T_B 100}{T}$$

I = 5 amp test current

T_B = Basic ohmic reach tap

T = Voltage restraint tap in percent

- b. Make the AC connections to the relay according to Table I. The letters A through F in Table I correspond to the letters in Figure 14.
- c. Adjust the variac in Figure 14 until the voltmeter reads 85% of the calibrated voltage in equation of above paragraph -2.
- d. Rotate the phase-shifter, holding the voltage at 85% of the maximum V , and record the two angles at which the output just approaches the verge of pickup.
- e. Add, algebraically, the two angles and divide the sum by two. The resultant should be the desired angle plus or minus 1.5 degrees.

PERIODIC CHECKS AND ROUTINE MAINTENANCE

PERIODIC TESTS

All functions included in the SLY52A relay may be checked at periodic intervals using the procedures described in the section INSTALLATION TESTS. Cable connections between the SLY52A and the associated Type SLA relay may be checked by observing the test points in the SLA unit.

The following checks should be made during periodic testing:

1. Basic minimum ohmic tap.
2. Voltage restraint tap setting.
3. Angle of maximum reach setting.
4. Characteristic timer settings.

These four checks can be made at once by making a plot of the mho characteristic.

TROUBLE SHOOTING

In any trouble shooting of equipment, it should first be established which unit is functioning incorrectly. The overall logic diagram supplied with the equipment shows the combined logic of the complete equipment and the various test points in each unit. By signal tracing, using the overall logic diagram and the various test points, it should be possible to quickly isolate the trouble.

A test adapter card is supplied with each static relay equipment to supplement the prewired test points on the test cards. Use of the adapter card is described in the card instruction book GEK-34158.

A dual-trace oscilloscope is a valuable aid to detailed trouble shooting, since it can be used to determine phase shift, operate and reset times as well as input and output levels. A portable dual-trace oscilloscope with a calibrated sweep and trigger facility is recommended.

SPARE PARTS

To minimize possible outage time, it is recommended that a complete maintenance program should include the stocking of at least one spare card of each type. It is possible to replace damaged or defective components on the printed circuit cards, but great care should be taken in soldering so as not to damage or bridge-over the printed circuit busses, or overhead the semi-conductor components. The repaired area should be recovered with a suitable high-dielectric plastic coating to prevent possible breakdowns across the printed busses due to moisture and dust. The wiring diagrams for the cards in the SLY52A relay are included in the card book GEK-34158; the card types are shown on the component location diagram (Figure 2).

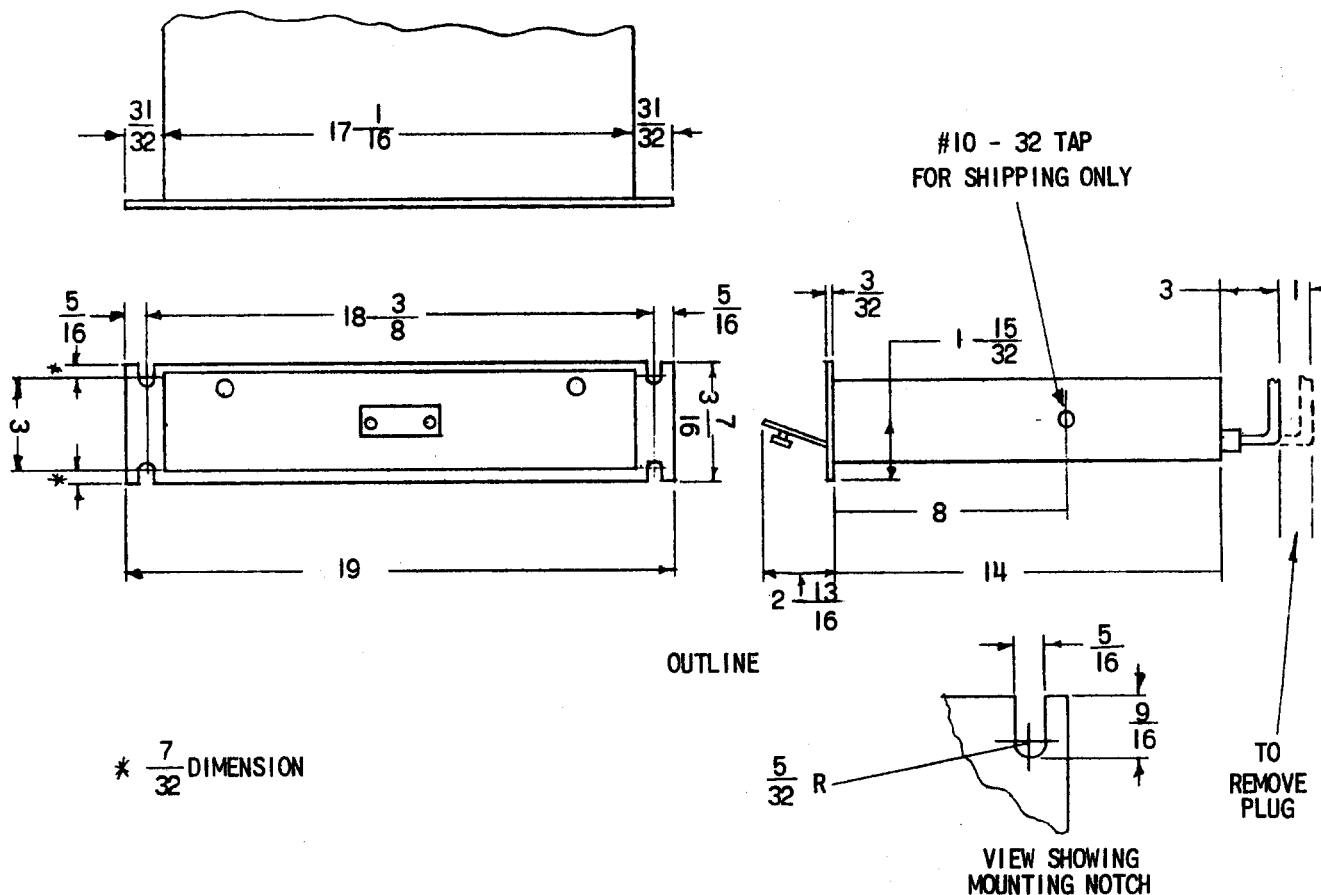
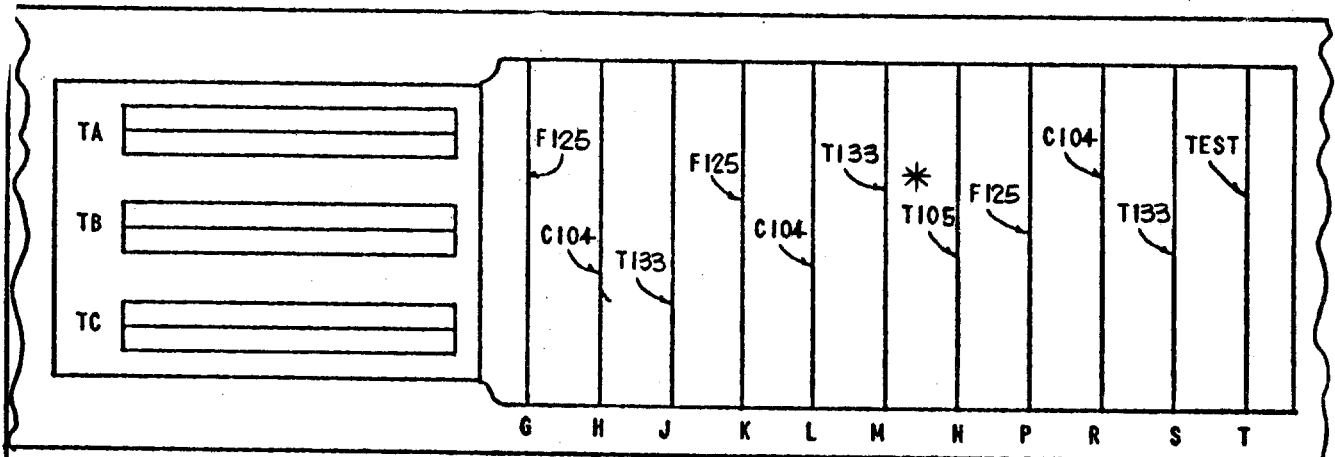
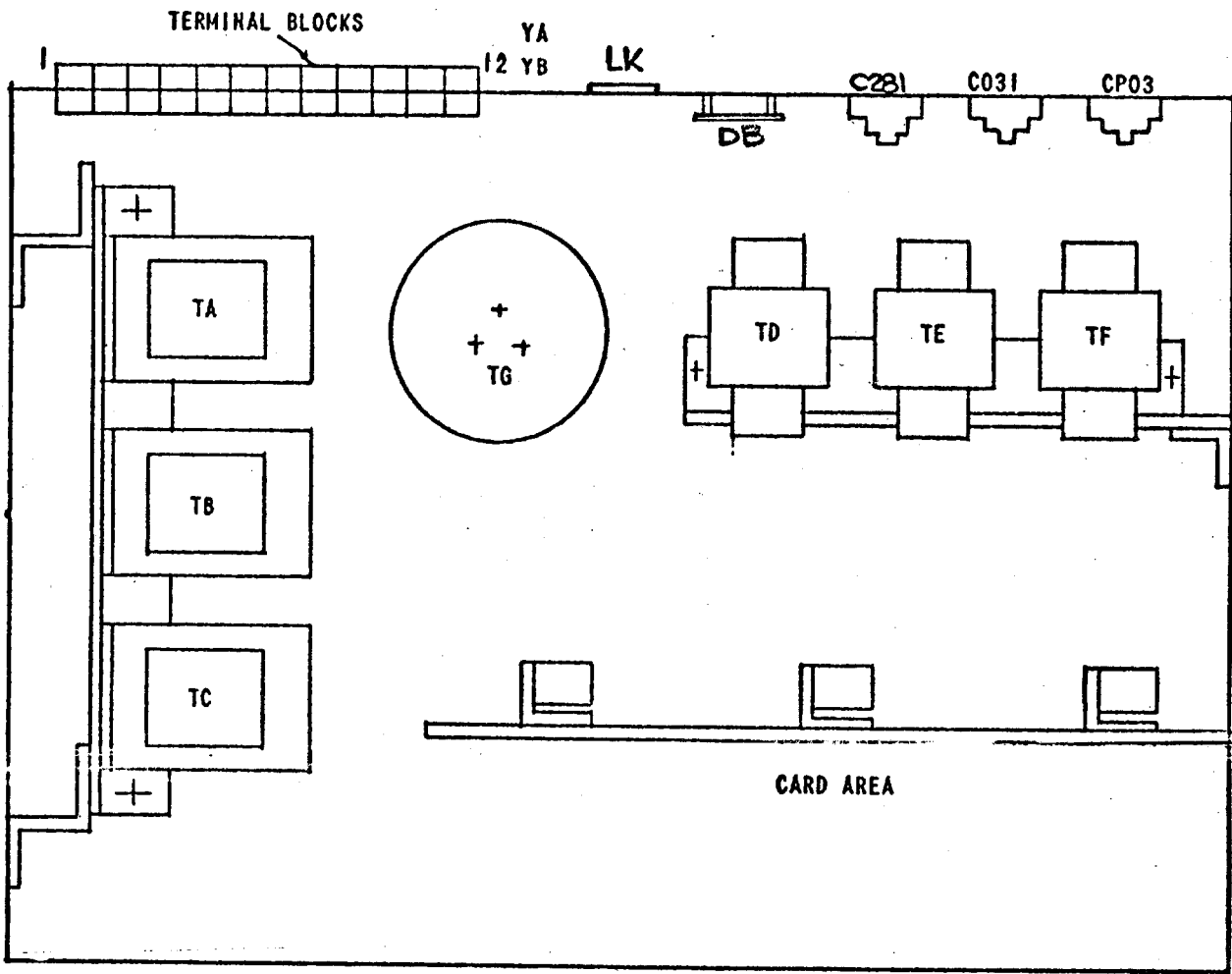

FIG. 1 (9227A2036-0) Outline and Mounting Dimensions for the Type SLY52A Relay.



* *OPTIONAL*

FIG. 2 (0257A6254-1) Component and Card Location Diagram for the Type SLY52A Relay.

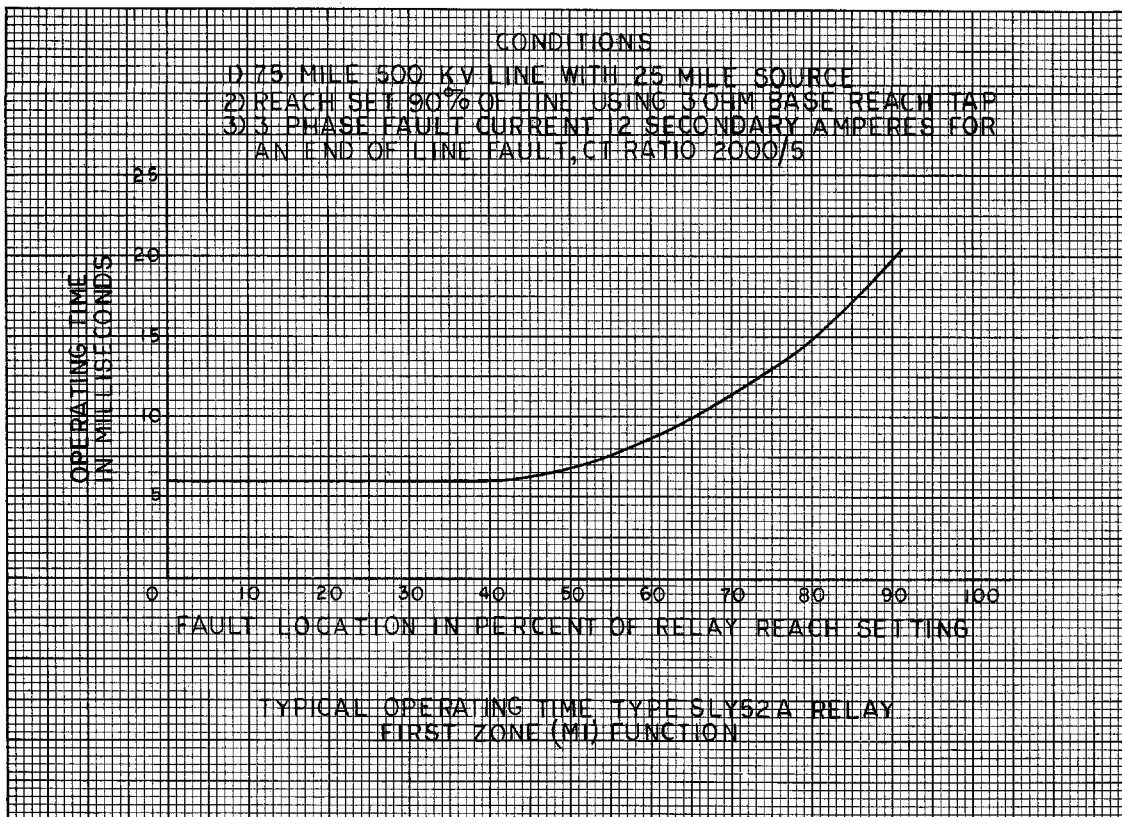

FIG. 4 (0257A8491-0) Typical Operating Time for the Type SLY52A Relay

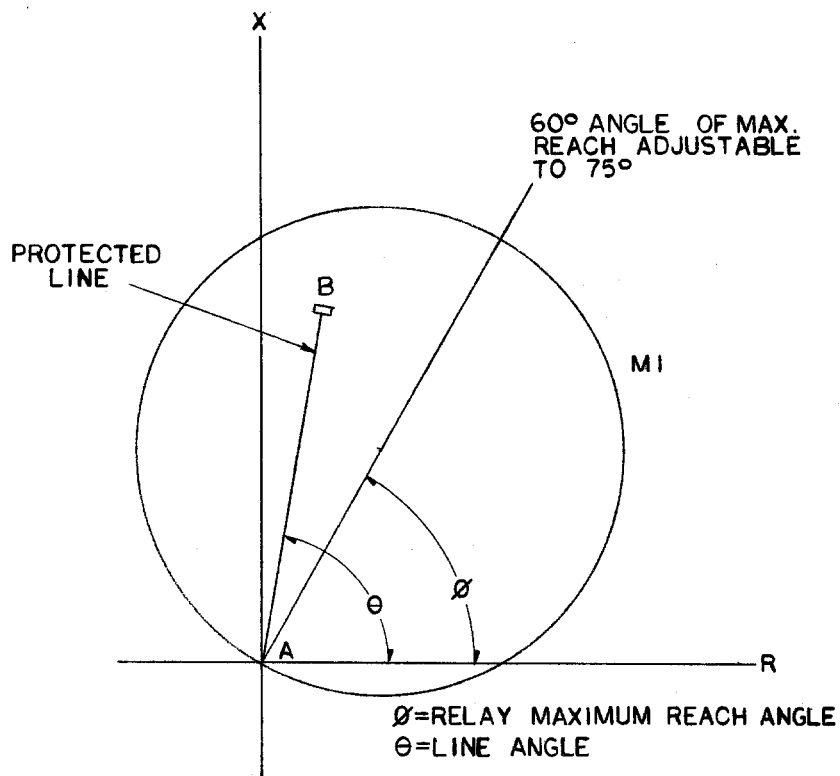
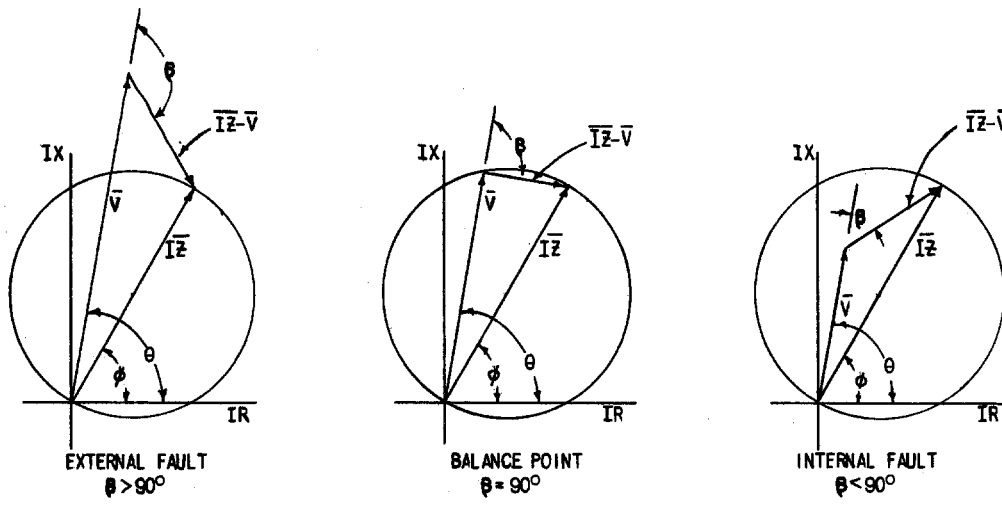

FIG. 5 (0269A1709-0) Typical MI Characteristic for the Type SLY52A Relay.



ϕ = RELAY MAXIMUM REACH ANGLE
 θ = LINE ANGLE

FIG. 6 (0227A2090-0) MHO Characteristic by P hase Angle Measurement.

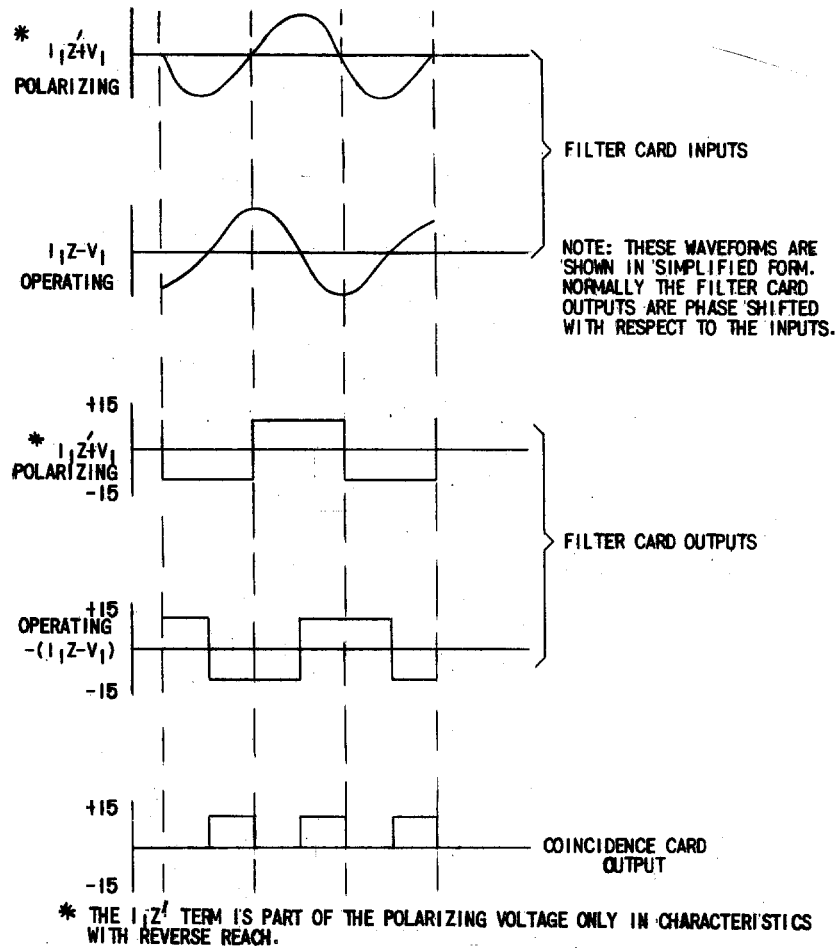

FIG. 7 (0246A7985-2) M1 Measurement Principles

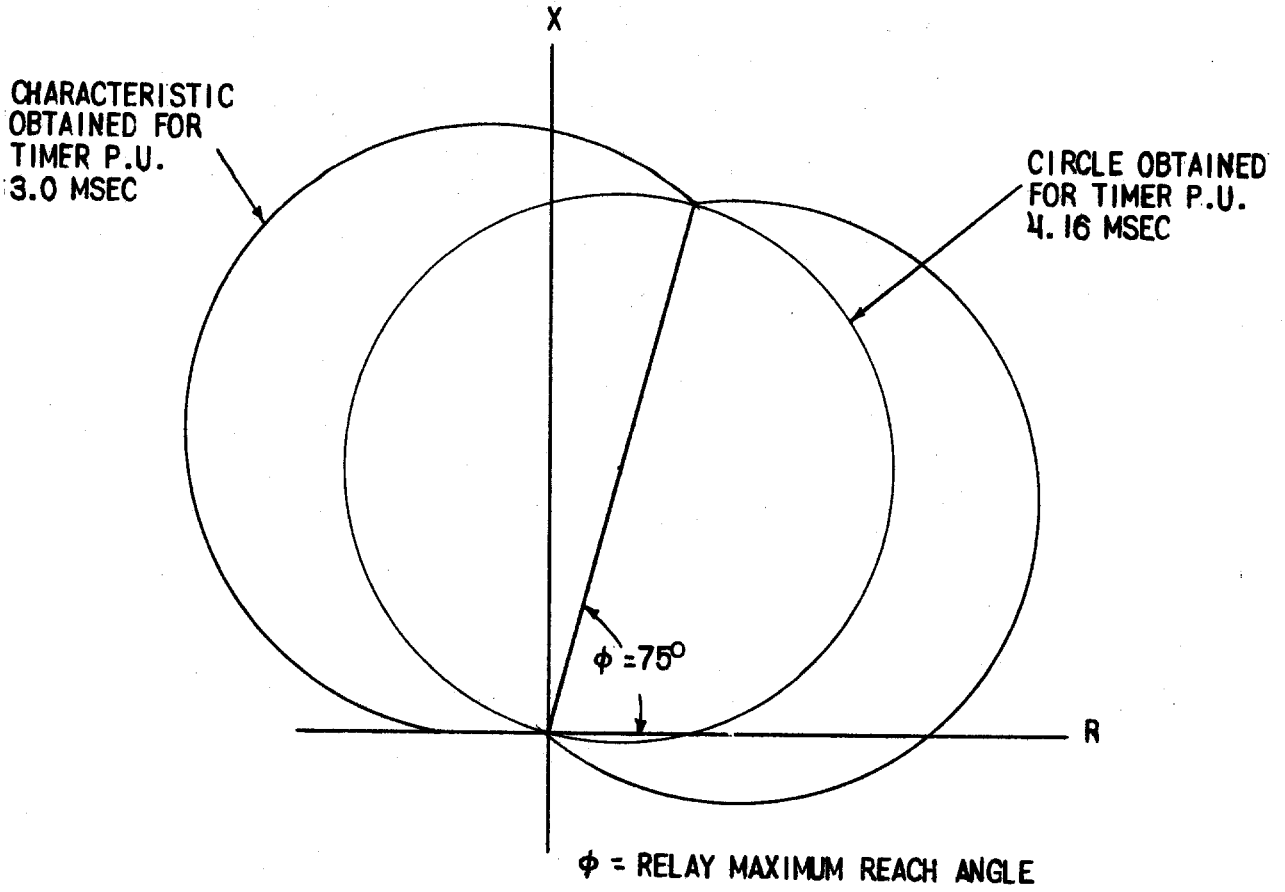

FIG. 8 (0227A2093-0) MHO Characteristic at 75° Angle of Maximum Reach with Variations in Timer Pickup Setting.

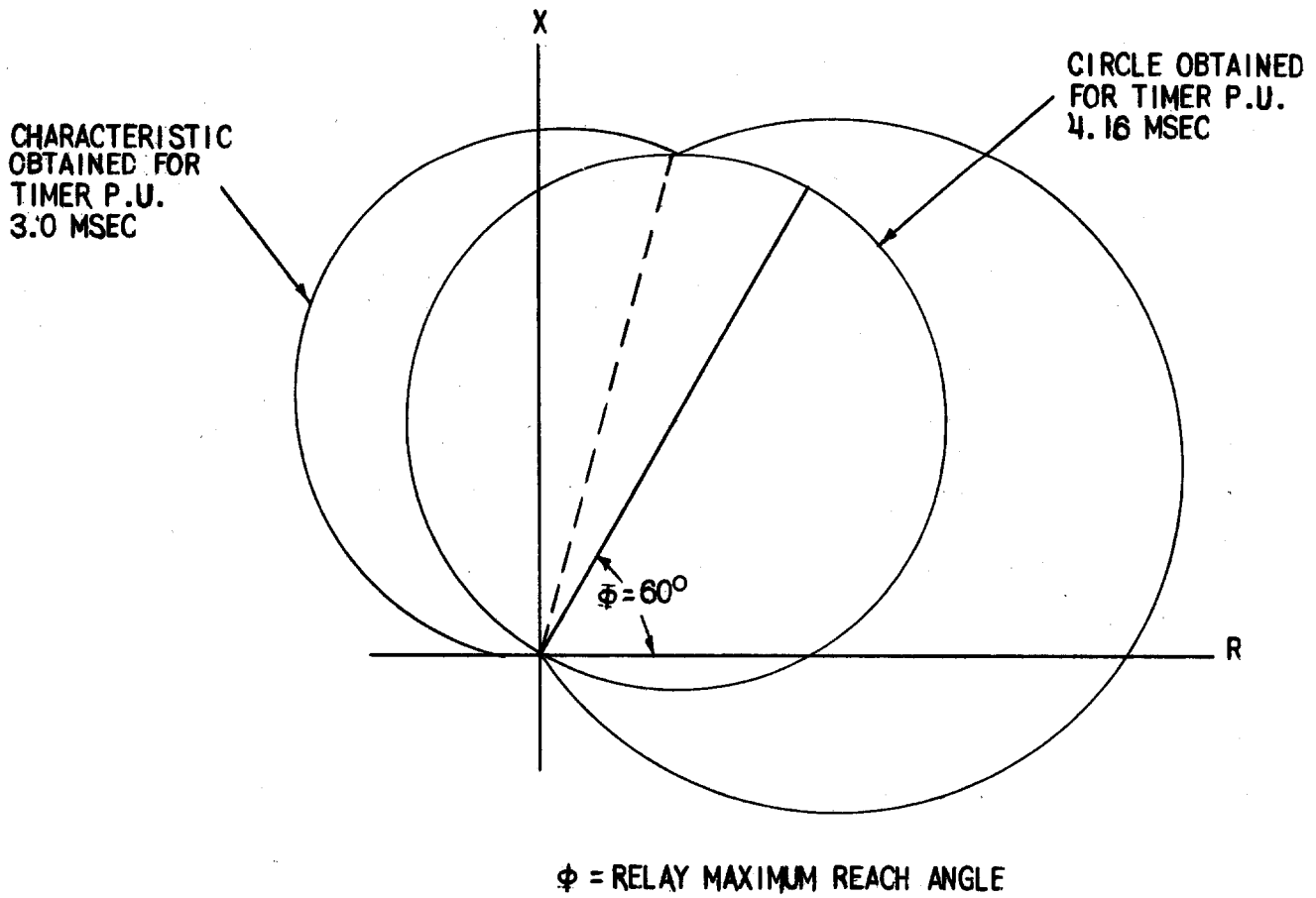

FIG. 9 (0227A2094-0) MHO Characteristic at 60° Angle of Maximum Reach with Variation in Timer Pickup Setting.

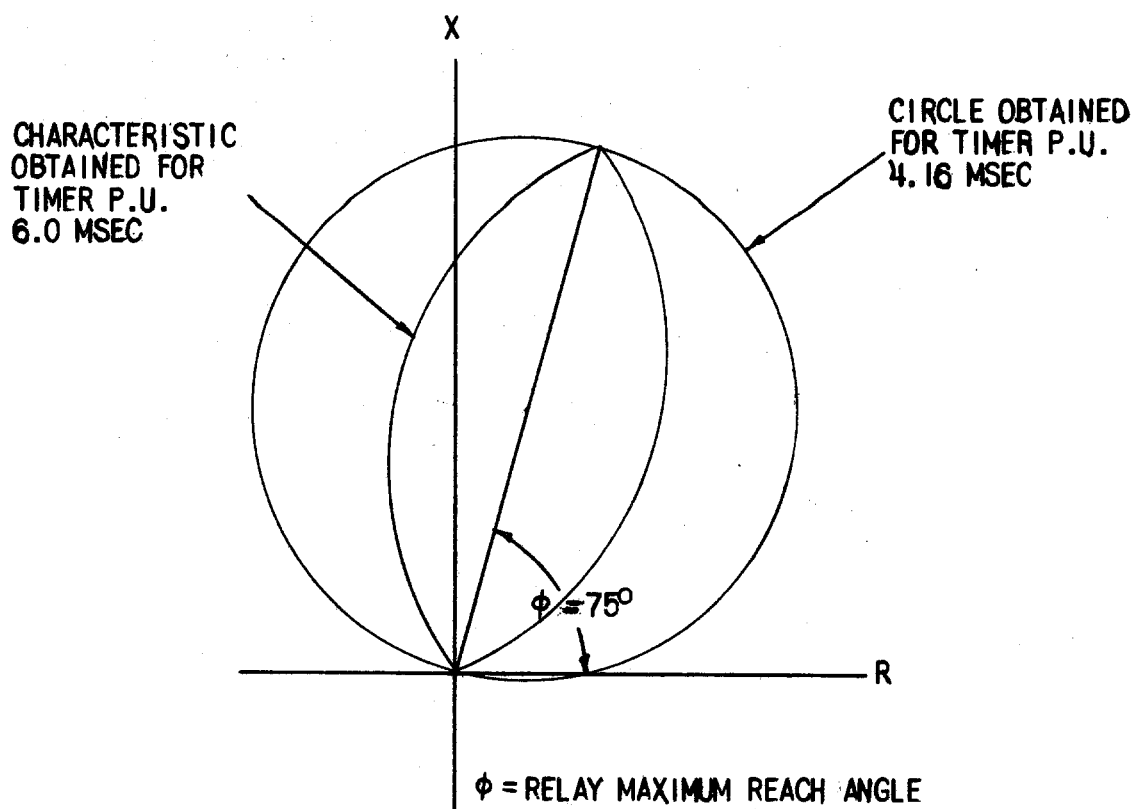

FIG. 10 (0227A2095-0) MHO Characteristic at 75° Angle of Maximum Reach with Variations in Timer Pickup Setting

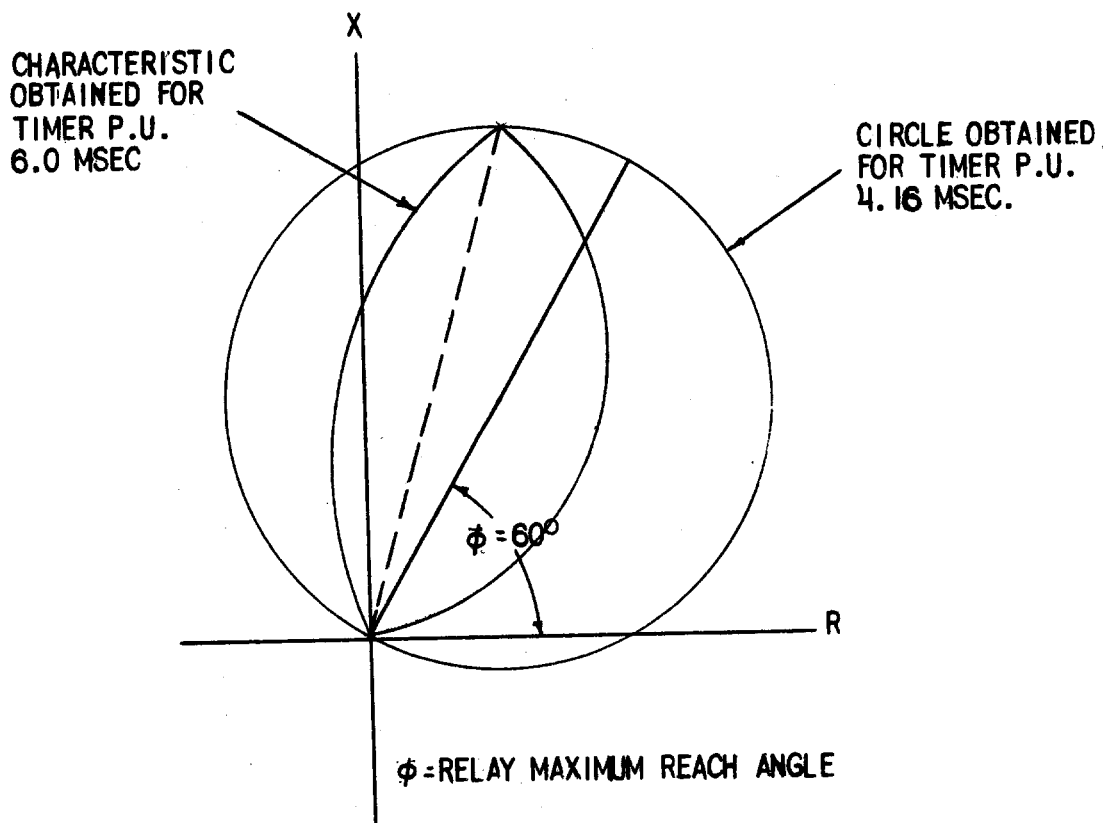

FIG. 11 (0227A2096-0) MHO Characteristic at 60° Angle of Maximum Reach with Variations in Timer Pickup Setting.

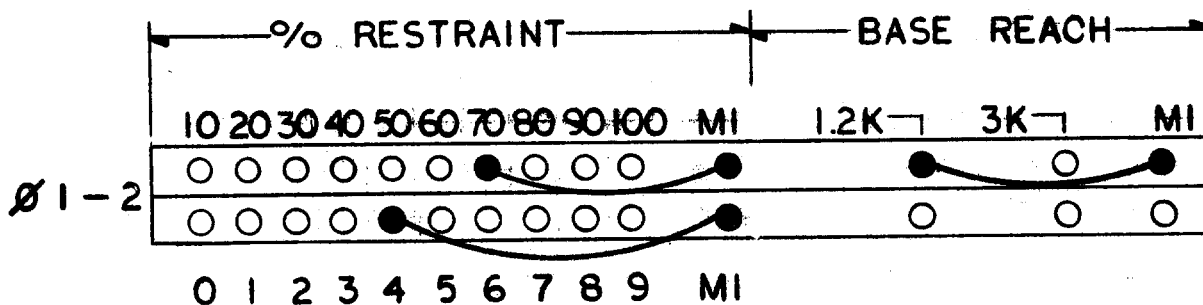
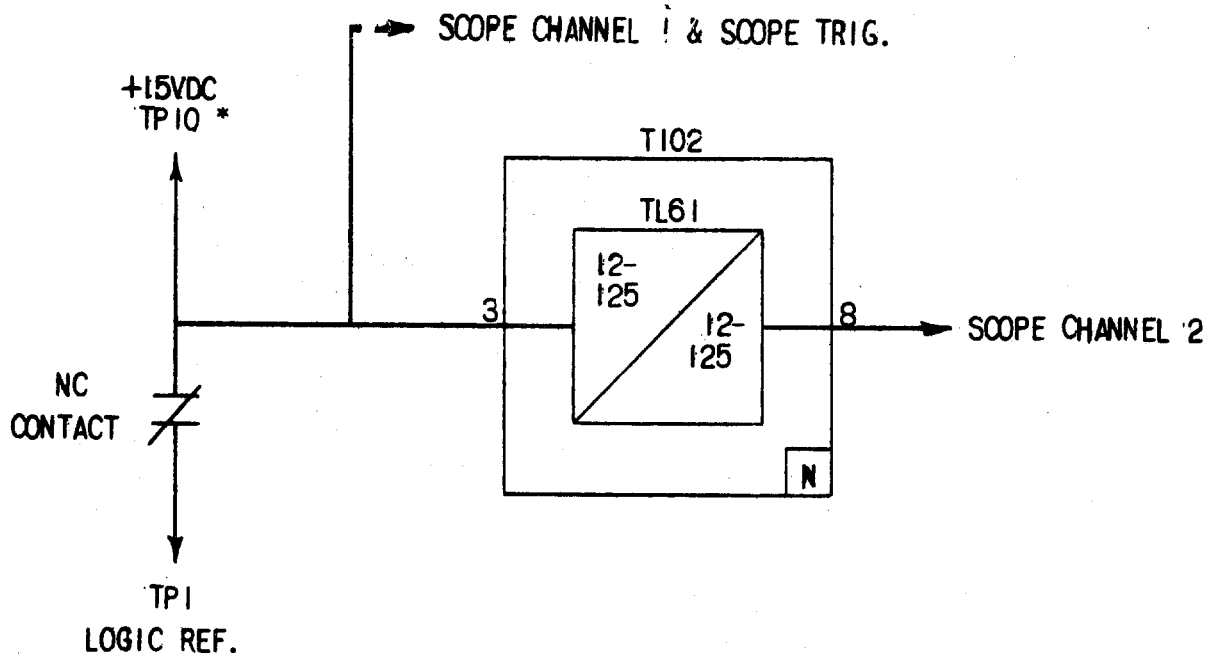

FIG. 12 (0269A1710-0) Typical SLY52A Tap Block Connections



* THE 15VDC SIGNAL AT PIN 10 HAS A CURRENT LIMITING RESISTOR MOUNTED ON THE TEST CARD.

FIG. 13 (0246A7987-0) Timer Test Circuit

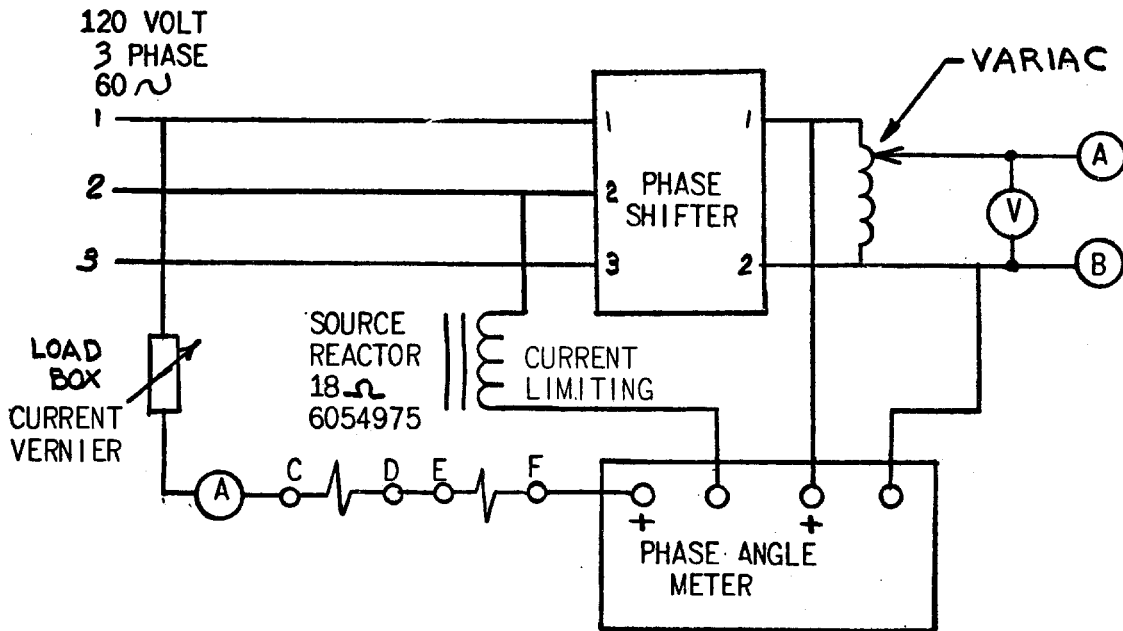

FIG. 14 (0178A7029-3) Phase Shifter Test Circuit

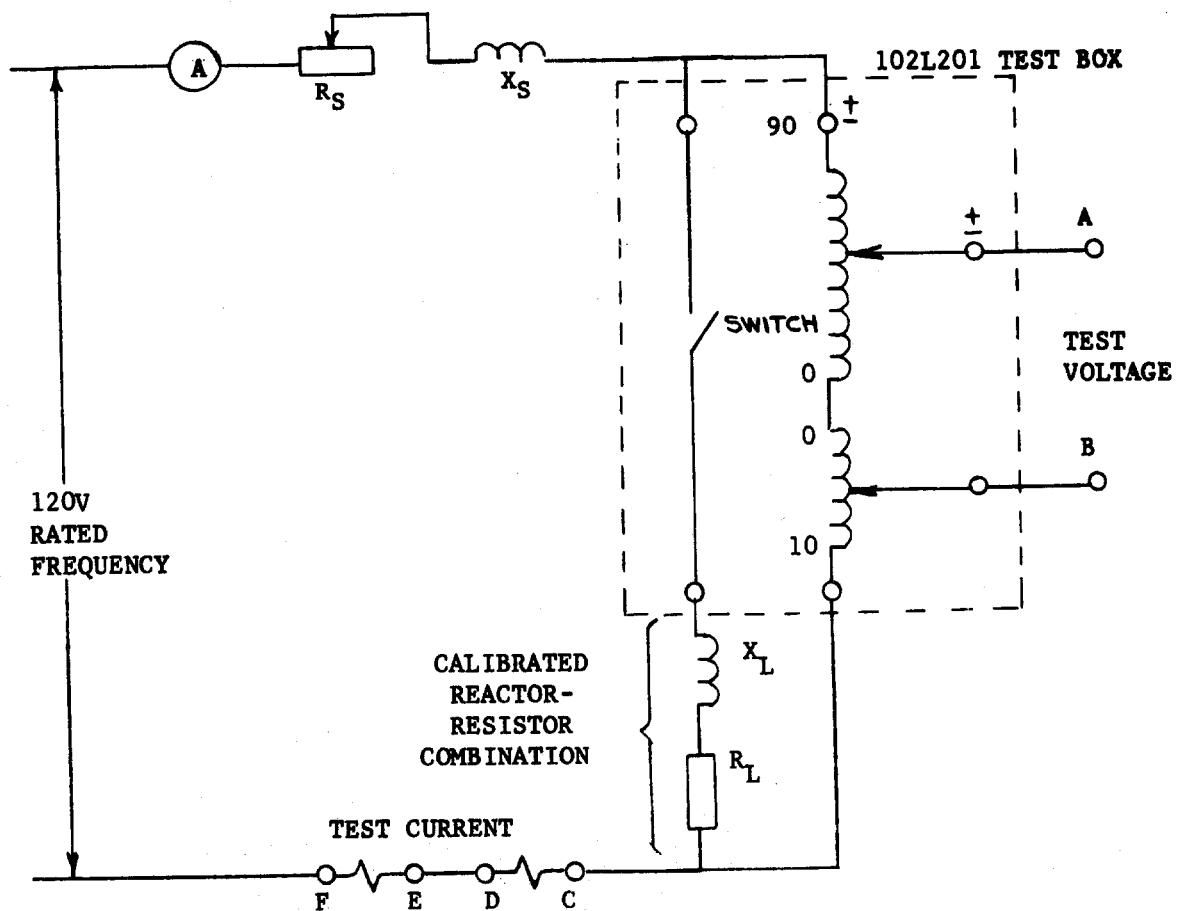

FIG. 15 (0178A7028-3) Test Circuit for Characteristic Check Using Test Box, Test Reactor, and Test Resistor

GENERAL ELECTRIC INSTALLATION AND SERVICE ENGINEERING OFFICES

FIELD SERVICE OFFICE CODE KEY

- * Mechanical & Nuclear Service
- † Electrical & Electronic Service
- ‡ Marine Service
- ‡ Transportation

FOR YOUR LASTING SATISFACTION . . . with the performance and availability of your General Electric equipment, GE provides this nationwide network of field service offices, serving utility, industrial, transportation and marine users. Qualified field engineers provide installation, start-up, employee training, engineering maintenance and other services, throughout the productive life of the equipment. For full information, call your nearest installation & Service Engineering office.

ALABAMA * † Birmingham 35205 . . . 2151 Highland Ave. * † Mobile 36609 . . . 1111 S. Beltline Highway	LOUISIANA * † Baton Rouge 70806 . . . 8312 Florida Blvd. * † New Orleans 70125 . . . 4747 Earhart Blvd. * † Shreveport 71104 . . . 2620 Centenary Blvd. * † Monroe 71201 . . . 1028 North 6th St.	OKLAHOMA * † Oklahoma City 73106 . . . 2000 Classen Blvd. * † Tulsa 74105 . . . P. O. Box 7646, Southside Sta.
ALASKA † Anchorage 99501 . . . 115 Whitney Rd.	MARYLAND * † Baltimore 21201 . . . 1 N. Charles St.	OREGON * † Eugene 97401 . . . 1170 Pearl St. * † Portland 97210 . . . 2929 NW 29th Ave.
ARIZONA * † Phoenix 85012 . . . 3550 N. Central Ave. † Tucson 85716 . . . 151 S. Tucson Blvd.	MASSACHUSETTS * † Wellesley 02181 . . . 1 Washington St.	PENNSYLVANIA * † Allentown 18102 . . . 1444 Hamilton St. * † Philadelphia 19102 . . . 3 Penn Center Plaza * † Pittsburgh 15222 . . . 300 6th Avenue Bldg.
ARKANSAS † North Little Rock 72119 . . . 120 Main St.	MICHIGAN * † Detroit 48202 . . . 700 Antoinette St. † Jackson 49201 . . . 210 W. Franklin St. † Saginaw 48607 . . . 1008 Second National Bank Bldg.	SOUTH CAROLINA † Columbia 29204 . . . 2700 Middleburg Dr. † Greenville 29607 . . . 41 No. Pleasantburg Dr.
CALIFORNIA * † Los Angeles 90054 . . . 212 N. Vignes St. † Palo Alto 94303 . . . 960 San Antonio Rd. † Sacramento 95808 . . . 2407 J St. † San Diego 92103 . . . 2560 First Ave. * † San Francisco 94119 . . . 55 Hawthorne St. * † Vernon 90058 . . . 3035 E. 46th St.	MINNESOTA † Duluth 55802 . . . 300 W. Superior St. * † Minneapolis 55416 . . . 1500 Lilac Drive So.	TENNESSEE * † Chattanooga 37411 . . . 5800 Bldg, Eastgate Center † Memphis 38130 . . . 3385 Airways Blvd.
COLORADO * † Denver 80206 . . . 201 University Blvd.	MISSOURI * † Kansas City 64199 . . . 911 Main St. * † St. Louis 63101 . . . 1015 Locust St.	TEXAS * † Amarillo 79101 . . . 303 Polk St. * † Beaumont 77704 . . . 1385 Calder Ave. * † Corpus Christi 78401 . . . 205 N. Chaparral St. † Dallas 75222 . . . 8101 Stemmons Freeway * † El Paso 79945 . . . 215 N. Stanton * † Fort Worth 76102 . . . 408 W. Seventh St. * † Houston 77027 . . . 4219 Richmond Ave. † San Antonio 78204 . . . 434 S. Main St.
CONNECTICUT * † Meriden 06450 . . . 1 Prestige Dr.	MONTANA † Butte 59701 . . . 103 N. Wyoming St.	UTAH † Salt Lake City 84111 . . . 431 S. Third East St.
FLORIDA † † Jacksonville 32203 . . . 4040 Woodcock Dr. † † Miami 33134 . . . 4100 W. Flagler St. * † † Tampa 33609 . . . 2106 S. Lois Ave.	NEBRASKA * † Omaha 68102 . . . 409 S. 17th St.	VIRGINIA * † Newport News 23601 . . . 311 Main St. † † Richmond 23230 . . . 1508 Willow Lawn Dr. † † Roanoke 24015 . . . 2018 Colonial Ave.
GEORGIA * † † Atlanta 30309 . . . 1860 Peachtree Rd., NW † † Savannah 31405 . . . 5002 Paulsen St.	NEW JERSEY * † Millburn 07041 . . . 25 E. Willow St.	WASHINGTON * † † Seattle 98188 . . . 112 Andover Park East, Tukwila † † Spokane 99202 . . . E. 1805 Trent Ave.
HAWAII * † † Honolulu 96813 . . . 440 Coral St.	NEW YORK † † Albany 12205 . . . 15 Computer Drive, West * † † Buffalo 14205 . . . 825 Delaware Ave. * † † New York 10022 . . . 64 Lexington Ave. * † † Rochester 14604 . . . 89 East Ave. * † † Syracuse 13206 . . . 3532 James St.	WEST VIRGINIA * † Charleston 25328 . . . 306 MacCorkle Ave., SE
ILLINOIS * † † Chicago 60680 . . . 840 S. Canal St.	NORTH CAROLINA * † † Charlotte 28207 . . . 141 Providence Rd. * † † Wilmington . . . Reigelwood 28456 . . . P. O. Box 186	WISCONSIN * † Appleton 54911 . . . 3003 West College Dr. * † Milwaukee 53202 . . . 615 E. Michigan St.
INDIANA † † Evansville 47705 . . . 2709 Washington Ave. † † Fort Wayne 46807 . . . 3606 S. Calhoun St. * † Indianapolis 46207 . . . 3750 N. Meridian St.	OHIO * † Cincinnati 45206 . . . 2621 Victory Pkwy. * † † Cleveland 44104 . . . 1000 Lakeside Ave. † † Columbus 43229 . . . 1110 Morse Rd. † † Toledo 43606 . . . 3125 Douglas Rd. † † Youngstown 44507 . . . 272 Indianola Ave.	WEST VIRGINIA * † Charleston 25328 . . . 306 MacCorkle Ave., SE
IOWA † Davenport 52805 . . . P. O. Box 630, 1039 State St., Bettendorf		
KENTUCKY † Louisville 40218 . . . 2300 Meadow Dr.		

GENERAL ELECTRIC SERVICE SHOPS

WHEN YOU NEED SERVICE . . . These GE Service Shops will repair, recondition, and rebuild your electric apparatus. The facilities are available day and night, seven days a week, for work in the shops or on your premises.

Latest factory methods and genuine GE renewal parts are used to maintain performance of your equipment. For full information about these services, contact your nearest service shop or sales office.

ALABAMA * Birmingham 35211 . . . 1500 Mims Ave., S. W. * Mobile 36609 . . . 721 Lakeside Dr.	LOUISIANA * Baton Rouge 70814 . . . 10955 North Dual St. * New Orleans 70114 . . . 1115 DeArmas St.	OKLAHOMA * Tulsa 74145 . . . 5220 S. 100th East Ave.
ARIZONA * (Phoenix) Glendale 85019 . . . 4911 W. Colter St. * Phoenix 85019 . . . 3840 W. Clarendon St. * Tucson 85713 . . . 2942 So. Palo Verde Ave.	MARYLAND * Baltimore 21230 . . . 920 E. Fort Ave.	OREGON * Eugene 97402 . . . 570 Wilson St. * Portland 97210 . . . 2727 NW 29th Ave.
CALIFORNIA * Los Angeles 90301 . . . 6900 Stanford Ave. * (Los Angeles) Anaheim 92805 . . . 3601 E. LaPalma Ave. * (Los Angeles) Inglewood 90301 . . . 228 W. Florence Ave. * Sacramento 95814 . . . 99 North 17th St. * (San Francisco) Oakland 94608 . . . 1650 34th St.	MASSACHUSETTS * Δ (Boston) Medford 02155 . . . 3960 Mystic Valley Pkwy.	PENNSYLVANIA * Allentown 18103 . . . 668 E. Highland St. * (Delaware Valley) Cherry Hill, N. J., 08034 . . . 1790 E. Marlton Pike * Johnstown 15802 . . . 841 Oak St. * Philadelphia 19124 . . . 1040 East Erie Ave. * (Pittsburgh) West Mifflin 15122 . . . 4930 Buttermilk Hollow Rd. * York 17403 . . . 54 N. Harrison St.
COLORADO * Denver 80205 . . . 3353 Larimer St.	MICHIGAN * Δ (Detroit) Riverview . . . 18075 Krause Ave. * Flint 48505 . . . 1506 E. Carpenter Rd.	SOUTH CAROLINA * (Charleston) No. Charleston 29401 . . . 2490 Debonair St.
CONNECTICUT * (Southington) Plantsville 06479 . . . 370 Atwater St.	MINNESOTA * Duluth 55807 . . . 50th Ave. W & St. Louis Bay * Minneapolis 55430 . . . 2025 49th Ave., N.	TENNESSEE * Knoxville 37914 . . . 2621 Governor John Sevier Hwy. * Memphis 38107 . . . 708 North Main St.
FLORIDA * Jacksonville 32203 . . . 2020 W. Beaver St. * (Miami) Hialeah 33010 . . . 1062 East 28th St. * Tampa 33601 . . . 19th & Grant Sts.	MISSOURI * Kansas City 64120 . . . 3525 Gardner Ave. * St. Louis 63110 . . . 1115 East Rd.	TEXAS * Beaumont 77705 . . . 1490 W. Cardinal Dr. * Corpus Christi 78401 . . . 115 Waco St. * Dallas 75235 . . . 3202 Manor Way * Houston 77036 . . . 5534 Harvey Wilson Dr. * Houston 77036 . . . 6916 Harwin Dr. * Midland 79701 . . . 704 S. Johnston St.
GEORGIA * (Atlanta) Chamblee 30341 . . . 5035 Peachtree Industrial Blvd. * Atlanta . . . 2379 John Glenn Dr.	NEW JERSEY * New Brunswick 08902 . . . 3 Lawrence St.	UTAH * Salt Lake City 84110 . . . 301 S. 7th West St.
ILLINOIS * Chicago 60638 . . . 6045 S. Nottingham Ave.	NEW MEXICO * Albuquerque 87109 . . . 4420 McLeod Rd. NE	VIRGINIA * Richmond 23224 . . . 1403 Ingram Ave. * Roanoke 24013 . . . 1004 River Ave., SE
INDIANA * Evansville 47711 . . . 401 N. Congress Ave. * Ft. Wayne 46803 . . . 1731 Edmall Ave. * Hammond 46320 . . . 1138 164th Place * Indianapolis 46222 . . . 1740 W. Vermont St.	NEW YORK * Albany 12205 . . . 1097 Central Ave. * (Buffalo) Tonawanda 14150 . . . 175 Milens Rd. * (Long Island) Old Bethpage 11804 . . . 183 Bethpage-Sweet Hollow Rd. * (New York City) North Bergen, N. J. 07012 . . . 6001 Tonnelle Ave. * (New York City) Clifton, N. J. 07012 . . . 9 Brighton Rd. * Δ Schenectady 12305 . . . 1 River Rd. * Syracuse 13208 . . . 1015 E. Hiawatha Blvd.	WASHINGTON * Seattle 98134 . . . 3422 First Ave., South * Spokane 98211 . . . E. 4323 Mission St.
IOWA * (Davenport) Bettendorf 52722 . . . 1025 State St.	OHIO * Akron (Canton) 44720 . . . 7900 Whipple Ave. N. W. * Cincinnati 45202 . . . 444 West 3rd St. * Δ Cleveland 44125 . . . 4477 East 49th St. * Columbus 43229 . . . 6660 Huntley Rd. * Toledo 43605 . . . 405 Dearborn Ave. * Youngstown 44507 . . . 272 E. Indianola Ave.	WEST VIRGINIA * Charleston 25328 . . . 306 MacCorkle Ave., SE
KENTUCKY * Louisville 40209 . . . 3900 Crittenden Drive		WISCONSIN * Appleton Menasha 54910 . . . 1725 Racine St. * Milwaukee 53207 . . . 235 W. Oklahoma Ave.

• Electrical/Mechanical Service Shop * Instrumentation Shop Δ Special Manufacturing Shop