



GEK-49861D

## ***INSTRUCTIONS***

---

**STATIC, THREE PHASE DIRECTIONAL PHASE  
DISTANCE RELAY**

**TYPE SLY81A, SLY81B**

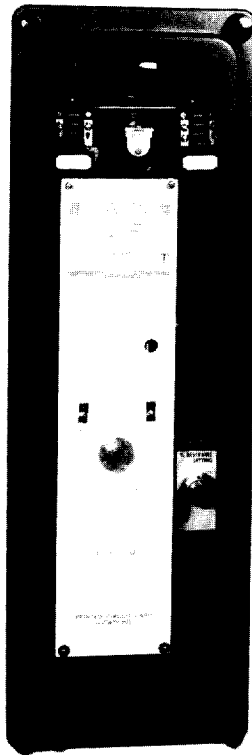

---

***GENERAL ELECTRIC***

TABLE OF CONTENTS

	<u>PAGE</u>
DESCRIPTION . . . . .	3
APPLICATION . . . . .	4
RATINGS . . . . .	4
GENERAL . . . . .	4
SURGE WITHSTAND CAPABILITY . . . . .	6
POWER SUPPLY . . . . .	6
CONTACTS . . . . .	6
TARGET . . . . .	6
CHARACTERISTICS . . . . .	7
OPERATING PRINCIPLES . . . . .	7
RELAY REACH . . . . .	8
OPERATING TIME . . . . .	8
SENSITIVITY . . . . .	8
BURDENS . . . . .	10
CIRCUIT DESCRIPTION . . . . .	11
CALCULATIONS OF SETTINGS . . . . .	13
MOB SETTING . . . . .	14
CONSTRUCTION . . . . .	15
RECEIVING, HANDLING, AND STORAGE . . . . .	16
ACCEPTANCE TESTS . . . . .	17
VISUAL INSPECTION . . . . .	17
MECHANICAL INSPECTION . . . . .	17
Cradle and Case Blocks . . . . .	17
Hi-Seismic Target Unit . . . . .	17
Telephone Relay . . . . .	18
Electrical Test, General . . . . .	18
Dielectric Tests . . . . .	18
Detailed Testing Instructions . . . . .	19
1. Required Settings . . . . .	19
2. Relay Base Reach Angle and Reach Check . . . . .	19
3. Testing Mho Characteristics . . . . .	21
4. Alternate Test Method for Reach Tests . . . . .	22
5. Integrating Timer Tests . . . . .	22
6. Overcurrent Supervision Tests . . . . .	23
7. MOB Tests . . . . .	24
INSTALLATION PROCEDURE . . . . .	25
INTRODUCTION . . . . .	25
SURGE GROUND AND RELAY CASE GROUND CONNECTIONS . . . . .	25
TEST PLUGS . . . . .	26
INSTALLATION TESTS . . . . .	26
PERIODIC TESTING AND ROUTINE MAINTENANCE . . . . .	27
CONTACTS . . . . .	27
ELECTRICAL TESTS . . . . .	27
SERVICING . . . . .	28
RENEWAL PARTS . . . . .	29
APPENDIX I . . . . .	31
APPENDIX II . . . . .	32
LIST OF ILLUSTRATIONS . . . . .	34

**STATIC, THREE PHASE DIRECTIONAL PHASE DISTANCE RELAY  
TYPES SLY81A AND SLY81B**

**DESCRIPTION**

The Type SLY81A relay is a three phase, first or second zone static phase distance relay. It is available with ratings of 60 hertz, five amperes (5 amps); 50 hertz, five amperes (5 amps); and 50 hertz, one ampere (1 amp). Five ampere (5 amps) rated relays are available with continuously adjustable ohmic reach ranges of 0.1 to 4 ohms phase-to-neutral or 0.75 to 30 ohms phase-to-neutral. One ampere (1 amp) rated relays are available with ohmic reach ranges of 0.5 to 20 ohms or 3.75 to 150 ohms. DC Power supply voltages available are 48, 110, or 125. A 250 volt rating is available with an external pre-regulator. Contact outputs are provided for tripping (two contacts each with target) and a contact connected to positive for auxiliary functions. The relay is mounted in a deep, large size, double-ended drawout (L2D) case.

The Type SLY81B is similar to Type SLY81A except that it contains an out-of-step blocking circuit, MOB, which during an out-of-step condition, operates a normally open output contact suitable for controlling an auxiliary relay.

The Type SLY81 relays may be used in a "stepped distance" protection scheme as the first, second or third zone of phase protection. It may also be used as an underreaching or overreaching tripping relay in any of the directional comparison schemes. If the directional comparison schemes use phase distance blocking relays, the Type SLY82A blocking relay (instruction book GEK-49862) should be used to co-ordinate with the SLY81 tripping relay.

The SLY81 relay has a "variable mho" characteristic, which provides an optimum accommodation of arc resistance.

The functional block diagram is shown in Figure 1. Internal connections for the SLY81A and SLY81B are shown in Figures 2 and 3 respectively. Typical external connections are shown in Figure 4.

*These instructions do not purport to cover all details or variations in equipment nor provide for every possible contingency to be met in connection with installation, operation or maintenance. Should further information be desired or should particular problems arise which are not covered sufficiently for the purchaser's purposes, the matter should be referred to the General Electric Company.*

*To the extent required the products described herein meet applicable ANSI, IEEE and NEMA standards; but no such assurance is given with respect to local codes and ordinances because they vary greatly.*

APPLICATION

The SLY81 relay utilizes a three input phase angle comparator for the phase distance measurement. The three inputs for the phase A-B measurements are:

- |     |                                 |                         |
|-----|---------------------------------|-------------------------|
| (a) | $(I_A - I_B) Z_{R1} - T V_{AB}$ | Operating Quantity      |
| (b) | $V_{AB} + KV_{AB1}$             | Polarizing Quantity     |
| (c) | $(I_A - I_B) Z_{R1}$            | Overcurrent Supervision |

where

- |                     |   |
|---------------------|---|
| $I_A$ and $I_B$     | are the currents in the faulted phases.   |
| $Z_{R1}$            | is the base reach impedance with an impedance angle of 85°.   |
| $TV_{AB}$           | is the faulted phase-to-phase voltage, multiplied by the restraint setting T.   |
| $V_{AB} + KV_{AB1}$ | is the faulted phase-to-phase voltage plus K times the positive sequence component of the faulted phase-to-phase voltage. K is a design constant equal to 0.3 per unit. |

The use of the positive sequence component of voltage in the polarizing signal results in a relay characteristic of the "variable mho" type; that is, the characteristic expands as the source impedance behind the relay increases, providing an automatic accommodation of increasing arc impedance. The positive sequence component of voltage in the polarizing signal also improves the directional integrity of the distance measurement.

The third input of the comparator provides an overcurrent supervision function. This input is adjustable so that it can be set above load current but below the minimum fault current in order to provide security from mis-operation due to potential failure.

The SLY81 has a characteristic which is adjusted by means of the setting on the characteristic timer. For short lines a circular characteristic is recommended, but, for longer lines, lines with unusually heavy load transfer, or three terminal lines where very large reach settings are applied, a lens shaped characteristic is recommended.

RATINGS

GENERAL

Type SLY81A and SLY81B relays are designed for continuous operation in ambient temperatures between -20°C and +55°C per ANSI standard C37.90. In addition, these relays will not malfunction nor be damaged if operated in an ambient up to 65°C.

The current circuits of the relays which are rated five amperes (5 amps) rms will carry 10 amperes continuously and will carry 250 amperes for one second (1 sec). The current circuits of the relays

which are rated one ampere (1 amp) rms will carry two amperes (2 amp) rms continuously and will carry 50 amperes rms for one second. The potential circuits are rated 69 volts rms line-to-neutral and will withstand 110% of this value continuously.

These relays are available with either short or long impedance ranges as shown in Table I

TABLE I

AVAILABLE REACHES

Relay Current Circuit Rating Amperes	Type	Base Reach Tap In Positive Sequence Ohms $Z_{R1}$	Impedance Range In Positive Sequence Ohms $Z_R$
5	SHORT	0.1	0.1 to 1.0
5	SHORT	0.2	0.2 to 2.0
5	SHORT	0.4	0.4 to 4.0
5	LONG	0.75	0.75 to 7.5
5	LONG	1.5	1.5 to 15.0
5	LONG	3.0	3.0 to 30.0
1	SHORT	0.5	0.5 to 5.0
1	SHORT	1.0	1.0 to 10.0
1	SHORT	2.0	2.0 to 20.0
1	LONG	3.75	3.75 to 37.5
1	LONG	7.5	7.5 to 75.0
1	LONG	15.0	15.0 to 150.0

Selection of the desired base reach tap ( $Z_{R1}$ ) is made by means of the three tap screws at the lower rear of the relay (see Figure 5). All three tap screws (A, B, C) must be in equal ohmic tap positions.

The relay reach ( $Z_R$ ) of the relay is continuously adjustable, within the range shown in Table I for a particular tap, by means of a three-gang-precision potentiometer at the lower front of the relay (see Figure 6). The 10-turn dial of this potentiometer is calibrated in percent restraint setting (T) and is adjustable from 10% (fully counterclockwise) to 110% (fully clockwise). The maximum recommended setting is 100%. An enlarged picture of the dial is shown in Figure 7.

The relay reach is given by equation (1):

$$Relay\ Reach = Z_R = \frac{100 \times Z_{R1}}{T} \tag{1}$$

where,

- T = Restraint setting in percent
- $Z_R$  = Relay reach in ohms
- $Z_{R1}$  = Base reach tap in positive sequence ohms

The relay reach should be within 5% of the value given by equation (1) if the ambient temperature is within the rated range of -20°C to +55°C.

SURGE WITHSTAND CAPABILITY

These relays will withstand ANSI C37.90A-1974 surge test without incorrect operation or damage to any component.

POWER SUPPLY

Models are available with ratings of 48 volts DC (38 to 56 volts), 110 volts DC (88 to 120 volts), or 125 volts DC (100 to 140 volts). The power supply contains a DC-to-DC converter to provide isolation between the DC input control power and the solid state circuitry of the relay. On relays with DC control voltage in excess of 125 volts, an external pre-regulator is used. This reduces the control voltage to 125 volts, suitable for input to the relay terminals.

CONTACTS

The trip contacts will make and carry 30 amperes for tripping duty. Their continuous current ratings are limited by the target ratings as listed in Table II.

The MOB contacts in type SLY81B will make and carry continuously three amperes (3 amps).

The interrupting ratings of both types of contacts are listed in Table II.

TABLE II

INTERRUPTING RATINGS IN AMPERES OF OUTPUT CONTACTS

VOLTAGE	TRIP OUTPUT CONTACTS		MOB OUTPUT CONTACT (SLY81 ONLY)	
	INDUCTIVE††	NON-INDUCTIVE	INDUCTIVE††	NON-INDUCTIVE
115 volts AC	0.75	2.0	0.3	0.8
230 volts AC	0.5	1.0	0.15	0.4
48 volts DC	1.0	3.0	0.4	2.0
125 volts DC	0.5	1.5	0.2	0.8
250 volts DC	0.25	0.75	0.1	0.4

†† The inductive ratings are based on an L/R ratio of 0.04 second.

TARGET

A target seal-in unit with 0.6 and 2 ampere taps is provided for the output contact between terminals 11, 12, and 13. A target with the same taps is provided for the contact between terminals 14 and 18. The ratings of each of these targets are given in Table III.

TABLE III

TARGET RATINGS

	0.6 Amp Tap	2.0 Amp Tap
Minimum Operating	0.6 amps	2.0 amps
Carry Continuously	1.2 amps	2.6 amps
Carry 30 Amps for	0.5 second	3.5 seconds
Carry 10 Amps for	5 seconds	30 seconds
DC Resistance	0.78 ohm	0.18 ohm
60 Hertz Impedance	6.2 ohms	0.65 ohm

CHARACTERISTICS

OPERATING PRINCIPLES

The mho characteristic in the SLY81 is obtained by converting relay currents into voltage signals (IZ), combining these IZ signals with signals proportional to the line voltage (V), and measuring the angle between the appropriate combinations to obtain the desired characteristic.

Currents are converted into IZ signals by means of transactors (XA, XB, and XC) which are air gap reactors with secondary windings. The transactors are tapped on the primary to provide the basic ohmic tap selection of 0.1, 0.2, or 0.4 ohms (5 ampere rated) for the short reach relay or 0.75, 1.5, or 3 ohms (5 ampere rated) for the long reach relay. The one ampere (1 amp) rated relay taps are 0.5, 1.0, or 2.0 for the short reach relay and 3.75, 7.5, or 15 ohms for the long reach relay.

The Z of the IZ quantity is the transfer impedance of the transactor and is equal to  $V_{OUT}/I_{IN}$ . The transactor secondaries have loading resistors across them. These resistors provide the desired angle  $V_{OUT}$  and  $I_{IN}$ . This angle determines the base reach angle of the relay.

A third signal, consisting of IZ only, is also compared to provide overcurrent supervision. The magnitude of this signal is adjustable so that it can be set between maximum load current and minimum fault current for the line being protected.

The phase angle between the three signals is compared in a "Coincidence Logic" (CL) circuit which puts out a rectangular voltage pulse when these signals are coincident. The width of this block of voltage is measured by an "Integrating Timer" (IT) circuit which provides a trip signal output when the pulse width exceeds a preset duration. If the timer is set for 90° (that is, 4.16 milliseconds in a 60 hertz system), a circular R-X characteristic is obtained. If the timer is set for less than 90°, a contracted circle (lens shaped) is obtained. Relays are shipped from the factory with the timer set for 90°.

The timing diagram for a typical condition is shown in Figure 8.

RELAY REACH

The balance point of the relay is defined as the point at which the operating quantity goes to a null which, for phase AB, is:

$$(I_A - I_B)Z_{R1} = \frac{TV_{AB}}{100}$$

or

$$V_{AB} = \frac{100 Z_{R1}}{T} (I_A - I_B)$$

where            T    = Restraint setting in percent  
                   Z<sub>R1</sub> = Base reach tap in position sequence ohms

For a phase A to phase B fault where I<sub>A</sub> = -I<sub>B</sub>

$$V_{AB} = \frac{2I_A Z_{R1}}{T} \times 100$$

The reach of the relay is defined as:

$$Z_R = \frac{V_{AB}}{2I_A} = \frac{100Z_{R1}}{T} \text{ Relay Reach in Ohms}$$

To set the relay for the desired reach, it is necessary to first select the proper "Base Reach Tap". This tap should be the highest "Base Reach Tap" that is smaller than the desired ohmic reach. The setting of the "Base Reach Tap" is explained under the section titled **CONSTRUCTION** in this book. After the "Base Reach Tap" is selected the "Percent Restraint Setting" may now be chosen to produce the required relay reach.

OPERATING TIME

Operating time is a function of the length of line being protected, the source impedance and the location of the fault. Figure 9 shows the average operating time for a type SLY81A relay when set for first zone protection of a typical 100 mile radial transmission line with a source impedance equivalent to a 25 mile line. Figure 10 shows the average operating time for the same line when the relay is set for second zone protection.

Appendix II shows a method of calculating average operating time for a specific transmission line and source combination.

SENSITIVITY

Sensitivity is defined as the steady state rms voltage or current (at the relay terminals) required for a particular quantity to pick up the relay if all quantities are in the optimum phase relationship.



The nominal sensitivities for the signal quantities in the SLY81 relay are as follows:

1. Polarizing Sensitivity:

Sensitivity is one percent (1%) of rated voltage.

2. Overcurrent Supervision Sensitivity:

Sensitivity is adjustable over the range shown in Table IV.

TABLE IV

OVERCURRENT ADJUSTMENT RANGE

BASE REACH TAP IN OHMS	ADJUSTMENT RANGE IN Ø-Ø AMPERES RMS	
0.1	4	- 10
0.2	2	- 10
0.4	1	- 10
0.75	0.52	- 10
1.5	0.26	- 10
3.0	0.13	- 10
0.5	0.8	- 2
1.0	0.4	- 2
2.0	0.2	- 2
3.75	0.11	- 2
7.5	0.052	- 2
15.0	0.026	- 2

3. Operate Circuit Sensitivity:

See Figure 11 for sensitivity in terms of  $V_{LL} \times \frac{(\%T)}{100}$

The current sensitivity for phase pair A-B is given by the relationship:

$$(I_A - I_B) Z_{R1} = \frac{0.032 (I_{rated})}{1 - X}$$

where:  $X = \frac{\text{Actual Relay Reach}}{\text{Nominal Relay Reach}}$

For example, if  $X = 0.8$  and  $Z_{R1} = 3$  ohms, then:

$$I_A - I_B = \frac{0.16}{3(1-0.8)} = 0.27 \text{ amperes}$$

For a phase to phase fault where  $I_A - -I_B$ ,

$$I_A - I_B = 2I_A = 0.27 \text{ amperes}$$

$$\text{or } I_A = 0.13 \text{ amperes}$$

Similarly for a three phase fault:

$$I_A = \frac{I_A - I_B}{\sqrt{3}}$$

$$I_A - I_B = \sqrt{3} I_A = 0.27 \text{ amperes}$$

or

$$I_A = 0.15 \text{ amperes}$$

BURDENS

The potential circuit burden per phase at 120 volts RMS is 0.4 volt-amperes, 0.2 watts, 0.35 vars.

The current circuit impedance per circuit measured at rated current is given in Table V below.

TABLE V

CURRENT CIRCUIT BURDENS

RELAY CURRENT RATING CURRENT CIRCUIT	5 AMPERES PHASE	1 AMPERE PHASE
Impedance, Z, in ohms	0.030	0.210
Resistance, R, in ohms	0.027	0.200
Reactance, X, in ohms	0.013	0.065

The current requirements at the DC control power input (studs 19 and 20) are given in Table VI below.

TABLE VI

DC CONTROL CIRCUIT BURDENS

RELAY RATED DC VOLTAGE	CONDITION OF OUTPUT RELAY K2	CONTROL CIRCUIT BURDEN IN MILLIAMPERES
48	Dropped Out	200
48	Picked Up	315
110	Dropped out	90
110	Picked Up	175
125	Dropped Out	80
125	Picked Up	155
250	Dropped Out	250†
250	Picked Up	250†

† Input to Studs A and C of external pre-regulator

CIRCUIT DESCRIPTION

The internal connections for types SLY81A and SLY81B are shown in Figures 2 and 3 respectively. The terminal numbers at the tops and bottoms of these diagrams represent the external connections to the relays. The external connections can be grouped as shown in Table VII.

TABLE VII

EXTERNAL CONNECTIONS

TERMINAL NUMBERS	DESCRIPTION
1 through 6	AC current inputs
7 and 8	MOB output contact (SLY81B only)
9	Trip contact (other end connected to #19)
10	Surge ground
11 through 13	Trip contact with target seal-in
14 through 18	Trip contact with target
15 through 17	AC potential inputs
19 and 20	DC control power input

The line-to-line input voltages are connected to the primaries of step down potential transformers ( $T_A$ ,  $T_B$ , and  $T_C$ ). The secondaries of these potential transformers are connected to the signal processing (SP) card as well as to a three-gang potentiometer. The voltages on the sliders of the potentiometers are also connected as inputs to the SP card.

The input phase currents pass through the primaries of transactors ( $X_A$ ,  $X_B$  and  $X_C$ ). The transactors produce secondary voltages proportional to their primary currents in magnitude; however, the secondary voltages lead their respective primary currents by a phase angle of  $85^\circ$ . Taps are provided on the primaries of these transactors and the secondary voltages are connected as inputs to the SP card.

TABLE VIII

OUTPUTS FROM SP CARD

OUTPUT SIGNAL FROM SP CARD	INPUT TO CARD
VAB, ABC, VCA	Combined Polarizing (CP)
$(I_A - I_B)Z_{R1} \times C_A \dagger\dagger$ $(I_B - I_C)Z_{R1} \times C_B \dagger\dagger$ $(I_C - I_A)Z_{R1} \times C_C \dagger\dagger$	Coincidence Logic (CL)
$(I_A - I_B)Z_{R1} - TV_{AB}$ $(I_B - I_C)Z_{R1} - TV_{BC}$ $(I_C - I_A)Z_{R1} - TV_{CA}$	Operate Signal (OS)

$\dagger\dagger C_A, C_B, C_C$  are constants which are adjustable from approximately 0 to 0.9 to permit adjustment of overcurrent supervision.

The SP card combines the previously mentioned quantities to produce various output signals which are then fed as inputs to other cards. Table VIII indicates the types of output signals produced by the SP card and which other cards are fed by each signal.

The combined polarizing (CP) card produces voltages,  $V_{AB} + 0.3 V_{AB1}$ ,  $V_{BC} + 0.3 V_{BC1}$  and  $V_{CA} + 0.3 V_{CA1}$  by algebraic summations of  $V_{AB}$ ,  $V_{BC}$ , and  $V_{CA}$ . These voltages are then filtered in active bandpass filters with natural frequencies ( $f_0$ ) equal to the system frequency. The three filtered voltages are fed to the CL card as polarizing quantities.

The operate signal (OS) card filters its input signals from the SP card in active bandpass filters with natural frequencies equal to system frequency. Circuitry is also provided to bypass this filtering for (IZ-TV) signals of large magnitudes. The outputs of the OS card are fed to the (CL) card as operating signals.

Each phase of the CL card has three input signals and produces a high logic (+15 volts DC) output signal whenever these signals have the proper instantaneous phase relationship. Table IX shows the various input signals for phase AB and where the signals are obtained. In order for the output of CL to be high, inputs 1 and 3 must have the same polarity and input 2 must have an opposite polarity.

TABLE IX

INPUTS TO CL CARD

INPUT NO.	INPUT SIGNAL	DERIVED FROM
1	Quadrature Polarizing	QP Card
2	Operate Signal	OS Card
3	(IA - IB)ZR1	SP Card

The CL card outputs are fed to the integrating timer (IT) card which measure the time that each CL output signal is high. If the input signal to the IT card is high for 4.16 milliseconds (50 hertz relays - 5.0 milliseconds) on a repetitive basis (or 5.5 milliseconds (50 hertz relays - 6.6 milliseconds) on a single shot basis), the output of the IT card will go to a high logic value which picks up a reed relay (K1) mounted on the power supply (PS) card. A normally open contact on K1 energizes a telephone relay (K2) mounted on the front panel. Two normally open contacts of K2 are connected in series with the coils of targets to provide the main tripping contacts (11 through 14 and 18). In addition, a third normally open contact of K2 is connected between terminals 19 and 9 without a target for auxiliary functions.

The input DC control power (48, 110, or 125 volts) is connected to the power supply (PS) card which contains a DC-to-DC converter. The outputs of the DC-to-DC converter are  $\pm 15$  volts DC regulated which supply the necessary control power to the other cards. The transformer in the DC-to-DC converter provides isolation between the

solid state circuitry of the relay and the input DC control power (i.e., station battery). A yellow LED monitors the output voltage from this internal power supply.

Type SLY81B has an additional MOB function which detects an out-of-step condition and operates a normally open output contact. The circuitry for this function is located on the SP card.

The internal connections and card layouts for each printed circuit card are listed in Table X. The printed circuit cards have test points accessible from the front of the cards. Each test point, except the reference connection "OV" on the PS card and AIN, BIN, and CIN on the IT card, is buffered by a resistor to prevent a disturbance to the circuitry if a test point is accidentally short circuited. The test points are labeled functionally; i.e. the AB phase input to the integrating timer is labeled "AIN". The internal connection drawings show the test points with the same label.

TABLE X

INTERNAL CONNECTIONS FOR CARDS

CARD DESIGNATION	CARD FUNCTION	FIGURE NUMBER OF INTERNAL CONNECTIONS	FIGURE NUMBER OF CARD LAYOUT
SP	Signal Processing (Type SLY81A)	12A	12B
SP	Signal Processing (Type SLY81B)	13A	13B
CP	Combined Polarizing	14A & 14B	14C
OS	Operate Signal	15A & 15B	15C
CL	Coincidence Logic	16A	16B
IT	Integrating Timer	17A	17B
PS	Power Supply (110-125 Volts DC)	18A	18B
PS	Power Supply (48 Volts DC)	19A	19B

CALCULATIONS OF SETTINGS

Assume that the line to be protected is approximately 70 miles long and has primary impedances as follows:

$$Z_1 = 42 \angle 83^\circ,$$

Assume CT ratio is 1000/5 and PT ration is 2000/1.

$$Z_1 = 42 \left( \frac{1000}{5} \right) \left( \frac{1}{2000} \right) = 4.2 \angle 83^\circ$$

FIRST ZONE RELAY SETTING

The first zone relay can be set up to 90% of the line impedance for positive sequence impedance angles above 75° and 85% for positive sequence impedance angles above 70°. For line angles lower than 70°, refer to the local GE sales office. Hence the reach  $Z_R = 0.9(4.2) = 3.78$  ohms.

- (a) Select  $Z_{R1}$  (base reach tap). The highest tap should be selected that is less than  $Z_R$ , which, in this case, is the three ohm tap on the long reach relay.
- (b) Select Restraint Setting (10% to 100%). The restraint setting then is obtained from the formula:

$$T = \frac{Z_{R1}}{Z_R}(100\%) = \frac{3.0}{3.78}(100) = 79\%$$

**NOTE:** See the **CONSTRUCTION** section of this book for details on how to obtain the base reach tap and restraint setting calculated in this section.

SECOND ZONE RELAY SETTING

The second zone relay is set in the same manner as the first zone relay except that a different reach is required. Assume that the second zone unit is used in a directional comparison scheme and a reach of 175% is desired,  $Z_R = 1.75 (4.2) = 7.35$  ohms.

- (a) Select  $Z_{R1}$ . Use three ohm base tap.
- (b) Restraint Setting

$$\frac{Z_{R1}}{Z_R}(100) = \frac{3}{7.35}(100) = 40.8\%$$

MOB SETTING (TYPE SLY81B ONLY)

There are two settings to be make in establishing a proper out-of-step blocking function. These settings are interrelated and will normally be based on system load flow and power swing studies. The MOB characteristic should be set much larger than the tripping characteristic, i.e., shorter pickup setting on the MOB characteristic timer, to permit the swing impedance to stay between the MOB and the tripping characteristic for the maximum time. On the other hand, the MOB should not operate on the maximum load flow over the line, otherwise tripping on a subsequent fault will be blocked.

The timer that determines the duration that the swing impedance is inside the MOB characteristic but outside the tripping characteristic should be set as short as possible to detect the fastest swings, and as long as possible to prevent the MOB from

operating on a fault. An appropriate setting is usually between two and four cycles pickup time. The settings are made by potentiometers on the SP card. An "OSB" plug arrangement is provided on the SP card. When this plug is in the "IN" position, the main output contacts are blocked from tripping during the out-of-step condition. When the plug is in the "OUT" position, the main output contacts are not blocked so that an out-of-step condition merely closes a reed relay contact between studs 7 and 8.

### CONSTRUCTION

The type SLY81 relay is assembled in a deep, large size, double-end (L2D) drawout case having studs at both ends in the rear for external connections. The electrical connections between the relay unit and the case studs are made through stationary molded inner and outer blocks between which nests a removable connecting plug which completes the circuits. The outer blocks attached to the case have the studs for the external connections, and the inner blocks have the terminals for the internal connections.

Every circuit in the drawout case has an auxiliary brush, as shown in Figure 20, to provide adequate overlap when the connecting plug is withdrawn or inserted. Some circuits are equipped with shorting bars (see internal connections in Figure 2) and on these circuits, it is especially important that the auxiliary brush make contact as indicated in Figure 20 with adequate pressure to prevent the opening of important interlocking circuits.

The relay is mounted in a steel framework called the cradle and is a complete unit with all leads terminated at the inner blocks. This cradle is held firmly in the case with a latch at both top and bottom and by a guide pin at the back of the case. The connecting plug, besides making the electrical connections between the respective blocks of the cradle and case, also locks the latch in place. The cover, which is drawn to the case by thumbscrews, holds the connecting plugs in place. The target reset mechanism is a part of the cover assembly.

The relay case is suitable for either semiflush or surface mounting on all panels up to two inches thick and appropriate hardware is available. However, panel thickness must be indicated on the relay order to ensure that proper hardware will be included. Outline and panel drilling is shown in Figure 22. For DC supply voltages greater than 125 volts it is necessary to use an external pre-regulator. The pre-regulator is packaged in a box made from compound plates and perforated steel siding. It can be mounted on the rear of the relay or at a convenient location near the relay. The outline and mounting dimensions for the pre-regulator are shown in Figure 30.

A separate testing plug can be inserted in place of the connecting plug to test the relay in place on the panel either from its own source of current and voltage, or from other sources. The relay can be drawn out and replaced by another which has been tested in the laboratory.

The potential transformers (TA, TB, and TC) and the transactors (XA, XB, and XC) are mounted at the rear of the cradle as shown in Figure 5. The tap block below the transactors is used to set the base reach to the value determined in the **CALCULATION OF SETTINGS** section of this book. The three leads tagged, A, B, and C should be connected to the desired ohmic value labeled  $\phi A$ ,  $\phi B$ , and  $\phi C$  respectively. FOR EXAMPLE, Figure 5 shows a base reach ( $Z_{R1}$ ) setting of 3.0 ohms and the leads are connected as follows:

lead C	----->	position 1
lead B	----->	position 4
lead A	----->	position 7

A base tap indicator is provided on the nameplate. The knob should be rotated until the number corresponding to the base reach setting is exposed.

Figure 23 shows a front view of the relay with the nameplate removed. This view shows the targets, the telephone relay and all adjustments other than the base reach tap described above.

The dial of the restraint setting potentiometer (T) is calibrated directly in percent with the number in the window indicating the 10's digit and the two digits on the dial indicating the units and decimal digits. An example is shown in Figure 7 with a setting of 84%. The dial can be adjusted from 10% to 110%. The lock must be disengaged (by turning the lever counterclockwise) in order to change the restraint setting but should be engaged again after the desired setting is made.

The other adjustments indicated in Figure 23 are trim potentiometers located on printed circuit cards. Most of these adjustments are set in the factory and should not normally require readjustment. See the **ACCEPTANCE TESTS** section of this book for the recommended procedures if adjustment is required.

### RECEIVING, HANDLING, AND STORAGE

These relays, when not included as a part of a control panel, will be shipped in cartons designed to protect them against damage. Immediately upon receipt of a relay, examine it for any damage sustained in transit. If injury or damage resulting from rough handling is evident, file a damage claim at once with the transportation company and promptly notify the nearest General Electric Sales Office.

Reasonable care should be exercised in unpacking the relay in order that none of the parts are injured or the adjustments disturbed.

If the relays are not to be installed immediately, they should be stored in their original cartons in a place that is free from moisture, dust and metallic chips. Foreign matter collected on the outside of the case may find its way inside when the cover is removed and cause trouble in the operation of the relay.



ACCEPTANCE TESTS

Immediately upon receipt of the relay an INSPECTION AND ACCEPTANCE TEST should be made to make sure that no damage has been sustained in shipment and that the relay calibrations have not been disturbed.

These tests may be performed as part of the installation or acceptance test at the discretion of the user.

Since operating companies use many different procedures for acceptance and installation tests, the following section includes applicable tests that may be performed on these relays.

VISUAL INSPECTION

Check the nameplate stamping to make sure that the model number and rating of the relay agree with the requisition.

Remove the relay from its case and check that there are no broken or cracked molded parts or other signs of physical damage, and that all screws are tight.

MECHANICAL INSPECTION

Cradle and Case Blocks

Check that the fingers on the cradle and the case agree with the internal connection diagram. Check that the shorting bars are in the correct position. Check that each finger with a shorting bar makes contact with the shorting bar. Deflect each contact finger to ensure that there is sufficient contact force available. Check that each auxiliary brush is bent high enough to contact the connection plug.

Hi-Seismic Target Unit

The target unit has an operating coil tapped at 0.6 and 2.0 amperes. The relay is shipped from the factory with the tap screw in the higher ampere position. The tap screw is the screw holding the right hand tap plate. To change the tap setting, first remove one screw from the left hand plate and place it in the desired tap. Next remove the screw from the undesired tap and place it on the left hand plate where the first screw was removed. See Figure 23. Screws should **never** be left in **both** taps at the same time.

TABLE XI

TARGET PICKUP CURRENTS

TAP	PICKUP CURRENT IN AMPERES
0.6	0.35 - 0.6
2.0	1.15 - 2.0

The backing strip should be so formed that the forked end (front) bears against the molded strip under the armature. Since mechanical adjustments may affect the Seismic Fragility Level, it is advised that no mechanical adjustments be made if seismic capability is of concern.

### Telephone Relay

With telephone relays in the de-energized position all circuit closing contacts should have a gap of at least 0.015 inch and all circuit opening contacts have a wipe of at least 0.005 inch. Gap may be checked by inserting a feeler gage between the contacts and wipe can be checked by observing the amount of deflection on the stationary contact before parting the contacts. The armature should then be operated by hand and the gap and wipe again checked as described above.

### Electrical Test, General

All alternating current operated devices are affected by frequency. Since non-sinusoidal waveforms can be analyzed as a fundamental plus harmonics of the fundamental frequency, it follows that alternating current devices (relays) will be affected by the applied waveform. Therefore, in order to properly test alternating current relays it is essential to use a sine wave source of current or voltage.

### Dielectric Tests

#### 1. Introduction

The surge capacitors (C1-C9 and C15-C20) used in the type SLY relay do not have voltage ratings to withstand AC hipot voltage; therefore, caution must be exercised when hipotting to avoid damaging these capacitors.

It is recommended that hipot tests be performed on a bench with the relay in its case. If the relay is to be hipot tested together with other apparatus in an equipment, all external connections to Terminal 10 (surge ground) must be removed.

The hipot test voltage should be 1500 volts rms, 50 or 60 hertz for new relays or 1125 volts rms, 50 or 60 hertz for other relays. New relays are defined as those which have not been in service, which are not more than one year old from the date of shipment, and which have been suitably stored to prevent deterioration. The duration of application of the test voltage for both old and new relays should be 60 seconds.

#### 2. Hipot Tests

(a) Common Mode Hipot Tests (All terminals to case):

Temporary connections should be made to tie all relay terminals, including Terminal 10, together. Hipot voltage can then be applied between this common connection and the relay case.

(b) Transverse Mode Hipot Tests (Between circuits):

For hipot tests between circuits of the relay, the surge capacitors must be temporarily disconnected from the surge capacitor buses inside the relay. The relay terminals should be jumped to provide the four groups of circuits shown in Table XII. Hipot voltage can then be applied between any two groups of circuits.

TABLE XII

CIRCUIT GROUPING FOR TRANSVERSE MODE HIPOT TESTS

CIRCUIT GROUP	JUMPER BETWEEN TERMINAL NUMBERS
AC Current	1, 2, 3, 4, 5, and 6
AC Potential	15, 16 and 17
DC Control Power	9, 19 and 20
Output Contacts	7, 8, 11, 12, 13, 14 and 18

An alternate test using a 500 volt DC megger can be performed between the circuit groups of Table XII with the surge capacitors connected in their normal manner. While this method does not test the relay to its full dielectric rating, it will detect some cases of degraded insulation.

3. Restoring Relay to Service

After the hipot or megger testing is completed, the surge capacitors should be reconnected to the surge capacitor buses and all external wiring to Terminal 10 should be reconnected. The reach tests described under the **ACCEPTANCE TESTS** section of this book should then be repeated.

Detailed Testing Instructions

1. Required Settings

Make certain all the relay settings have been made. These should be in accordance with the setting calculations. The settings are:

- (a) Base reach ( $Z_{R1}$ ) is set on the tap block at rear of relay. All three phase settings should be the same.
- (b) Percent restraint (T) is set on the precision potentiometer on the front of the relay.

2. Relay Base Reach Angle and Reach Check

The following procedure is recommended to check the base reach angle ( $\emptyset$ ) and the relay reach setting ( $Z_R$ ).

- (a) Place the "OSB" plug in the "OUT" position (for Type SLY81B only).

- (b) Make the test connections shown in Figure 31 for the particular phase being tested. (The test connection shown in Figure 24 may also be used.)
- (c) Adjust the load box until the ammeter indicates the desired test current ( $I_T$ ). See Table XIII for the recommended test current for a desired reach.

TABLE XIII

RECOMMENDED TEST CURRENT			
5 AMPERE RATED RELAY		1 AMPERE RATED RELAY	
BASE REACH TAP	RECOMMENDED MINIMUM TEST CURRENT	BASE REACH TAP	RECOMMENDED MINIMUM TEST CURRENT
0.1	20††	0.5	4††
0.2	20††	1.0	4††
0.4	10††	2.0	2
0.75	8	3.75	1.6
1.5	4	7.5	0.8
3	2	15.0	0.4

†† The relay is not rated to carry this current continuously. It should not be applied longer than five minutes with an off time of at least five minutes

- (d) Adjust the phase angle for the nominal base reach angle of 85°.
- (e) Observe the waveform at the following test point (on OS card) with an oscilloscope.
  - 1) "AOUT" for phase pair A-B
  - 2) "BOUT" for phase pair B-C
  - 3) "COUT" for phase pair C-A

†† (f) Lower the voltage V to the value given in equation (2) below:

$$V_T = 2 \times I_T \times Z_{R1} \times \frac{100}{T} \tag{2}$$

where  $I_T$  = test current in amperes RMS  
 $T$  = restraint voltage setting in percent  
 $V_T$  = pickup voltage at the base reach angle in volts RMS  
 $Z_{R1}$  = base reach tap in ohms

††  $V_T$  should not be greater than 110% of rated voltage. If  $V_T$  is greater, reduce  $I_T$  until  $V_T$  is correct.

- (g) As the voltage is lowered, observe the waveform at the test point designated in step e). At the point where the telephone relay (K2) picks up, a slight adjustment of the phase angle and input voltage will cause the waveform to be reduced to a null consisting of only third and fifth harmonics. At this null point, the angle on the phase angle meter is the base reach angle  $\theta$  and should be within  $2^\circ$  of the nominal value of  $85^\circ$ . The voltage  $V_T$  at this null condition should be within 5% of the value calculated by equation (1).

**NOTE:** The measured pickup should agree with the calculated value within  $\pm 5\%$ . If the values do not agree within these limits, it is recommended that the test setup and meter calibrations be checked before the factory settings on the relay are disturbed. One good method of checking the test set up and procedure is to repeat the tests on a duplicate relay.

- (h) If it is desired to readjust the reach so that measured pickup occurs at a value closer to the calculated value, this may be accomplished by means of the trim potentiometers on the SP card. The potentiometer to be adjusted for each phase is shown in Table XIV. These potentiometers should be turned clockwise to increase the reach.

TABLE XIV

REACH ADJUSTMENT LOCATIONS	
PHASE UNDER TEST	POTENTIOMETER DESIGNATION
AB	P1
BC	P3
CA	P5

- (i) Replace the "OSB" plug in the "IN" position if blocking of main output contacts is desired during an out-of-step condition (Type SLY81B only).

### 3. Testing Mho Characteristics

The complete mho characteristic can be measured by the test circuit shown in Figure 31. (Note: The test circuit shown in Figure 24 may also be used for measuring the complete mho characteristic, but, if this circuit is used, the test results may indicate that the characteristic pulls back at some angles. This pull back is due to an inadequate amount of positive-sequence polarizing voltage being produced by this circuit.) The procedure is similar except that the phase shifter is adjusted until the phase angle meter indicates the angle of interest. Reduce the voltage out of the variac until the relay picks up and the value of  $V_T$  at this point should be as given by equation (3).

††

$$V_T = 2 \times I_T \times Z_{R1} \times \frac{100}{T} \cos(\alpha - \phi) \tag{3}$$

where  $\alpha$  = angle read by phase angle meter in degrees  
 $\phi$  = 85° = relay base reach angle in degrees

All other parameters are as defined under equation (2).

Recommended angles for testing are 55° and 115° at which angles equation (2) reduces to:

††

$$V_T(30) = 2 \times I_T \times Z_{R1} \times \frac{100}{T} \cos 30^\circ = \frac{173}{T} \times I_T \times Z_{R1} \tag{4}$$

where: ††  $V_T(30)$  = test voltage at ±30° from angle of maximum reach

††  $V_T$  should not be greater than 110% of rated voltage.  
 If  $V_T$  is greater, reduce  $I_T$  until  $V_T$  is correct.

Note: If  $I_T$  is not at least three times the value of the Overcurrent Supervision setting, a distorted Mho Characteristic may be measured.

#### 4. Alternate Test Method for Reach Tests

An alternate method of testing the relay characteristic is shown in Figure 25 where the R-X test combination is employed. The circuit uses the test box (102L201), test reactor (6054975) and test resistor (6158546) described in GEI-44236. Since a limited number of resistor-reactor fault impedances are available, only a few points on the relay characteristic can be checked.

#### 5. Integrating Timer Tests

The integrating timer (IT) card has three adjustments as indicated in Table XV.

TABLE XV

POTENTIOMETER DESIGNATION	POTENTIOMETER LOCATION	FUNCTION	60 HZ RELAY FACTORY SETTING MILLISECONDS	50 HZ RELAY FACTORY SETTING MILLISECONDS
P1	Bottom	Transient Pickup Time	5.5	6.6
P2	Top	Steady State Pickup Time	4.16	5.0
P3	Middle	Dropout Time	5	6

These potentiometers have been factory set and should not be adjusted unless a plot of the mho characteristics indicates an improper pickup time setting. The timer has a 5.5, 4/5 (50 hertz - 6.6, 5/6) time setting. The P1 potentiometer, used for transient

operation, has been set in co-ordination with the P2 potentiometer at the factory and sealed. Potentiometer P1 must not be readjusted. Potentiometer P2 is set for a 4.16 millisecond (50 hertz - 5.0 milliseconds) pickup time. The 4.16 millisecond (50 hertz - characteristic; times longer than 4.16 milliseconds (50 hertz - 5.0 milliseconds) tend to narrow the characteristic and times shorter than 4.16 milliseconds (50 hertz - 5.0 milliseconds) tend to widen the characteristic. Turning the P2 potentiometer clockwise will increase the pickup time delay. Potentiometer P3 is set for a five millisecond (50 hertz - 6.0 milliseconds) dropout time delay. Turning the P3 potentiometer clockwise will increase the dropout time delay.

The test circuit of Figure 31 may be used to check the steady state pickup time setting. (The same results will be obtained if the test circuit of Figure 24 is used in place of the test circuit of Figure 31.) A dual trace oscilloscope should be used with channel "A" connected to test point "AIN" on the IT card and channel "B" on test point "OUT" on the IT card. Connect unused inputs "AIN", "BIN", or "CIN" on IT card to "OV" test point on PS card. In order to observe the pickup time delay, the dropout time delay must be reduced by turning P3 counterclockwise so that the output resets each half cycle. Reduce " $V_T$ " until the relay picks up and the output (channel B) should go positive 4.16 milliseconds (50 hertz - 5.0 milliseconds) after the input (channel A) goes positive. After the pickup time is checked, P3 should then be turned clockwise until the output (channel B) produces a continuous positive signal. P3 should then be turned clockwise for one additional turn.

As a final check on the accuracy of the 4.16 milliseconds, (50 hertz - 5.0 milliseconds) the mho characteristic may be rechecked and compared with the desired characteristic.

To check the transient pickup time setting, the following procedure should be used:

- (a) Remove the CL card
- (b) Connect the test circuit of Figure 26
- (c) With the oscilloscope trigger on positive slope, open the normally closed contact. The Channel Two trace should step positive 5.5 milliseconds (50 hertz - 6.6 milliseconds) ( $\pm 0.1$  millisecond) after the Channel One trace steps positive.

## 6. Overcurrent Supervision Tests

There are potentiometers on the SP card for adjustment of the sensitivity of the overcurrent supervision signal for each phase pair as shown in table XVI.

The test circuit for setting sensitivity of the overcurrent supervision signal is shown in Figure 24 (or Figure 31). The recommended procedure for setting sensitivity is as follows:

- a) Make connections for phase pair AB and adjust current  $I_T$  to the desired value of current supervision (between maximum load current and minimum fault current). Set the phase shifter for a phase angle meter reading at  $85^\circ$ .

TABLE XVI

OVERCURRENT SUPERVISION ADJUSTMENT

POTENTIOMETER DESIGNATION	ADJUSTMENT FOR PHASE PAIR
P2	AB
P4	BC
P6	CA

- b) Reduce voltage  $V_T$  until continuity tester indicates that the main output contacts are closed. Reduce  $V_T$  to approximately 80% of this voltage and maintain at this value.
- c) Turn potentiometer P2 clockwise until the continuity tester indicates that the main output contacts are open.
- d) Alternately raise and lower current  $I_T$  slightly and check that output contacts are open for values of  $I_T$  slightly less, and closed for values of  $I_T$  slightly more, than the desired sensitivity setting. (The output contacts should be closed for values that are 10% higher than the desired sensitivity setting).
- e) Change connections to phase pair BC and repeat steps a) through d) except use potentiometer P4 for adjustment.
- f) Change connections to phase pair CA and repeat steps a) through d) except use potentiometer P6 for adjustment.

Note: In order to set the sensitivity of the overcurrent supervision to a value near the low end of the setting range given in Table IV, it may be necessary to change the relay restraint setting to a very low value. If the test circuit shown in Figure 31 is used in place of the one shown in Figure 24, this change in the relay restraint setting will not be necessary.

7. MOB Tests (Type SLY81B only)

There are two timer adjustments on the "SP" card for setting the MOB function. These adjustments are listed in Table XVII.

TABLE XVII  
MOB FUNCTION ADJUSTMENT

POTENTIOMETER DESIGNATION	TIMER FUNCTION	ADJUSTMENT RANGE (MILLISECONDS)	60 HZ RELAY FACTORY SETTING (MILLISECONDS)	50 HZ RELAY FACTORY SETTING (MILLISECONDS)
P7	Characteristic	2 - 5	3	3.6
P8	Duration	33 - 67	50	60

The test circuit for checking either of these timer settings is shown in Figure 27. The recommended procedure for checking the "CHARACTERISTIC TIMER" is as follows:

- a) Connect Channel One of the oscilloscope to test point "BIN" on the "IT" card. Trigger the oscilloscope from this channel with positive slope.



- b) Set current  $I_T$  at the value shown in Table XIII and adjust the phase shifter until the phase angles meter reads approximately  $75^\circ$ .
- c) Close switch S1 and slowly reduce voltage  $V_T$  until Channel Two of the oscilloscope goes low and measure the width of the timer input blocks on Channel One for this condition. This time is the setting of the "CHARACTERISTIC TIMER", and it can be increased by turning potentiometer P7 clockwise.

In order to check the "DURATION TIMER" setting, the following procedure is recommended:

- a) Change Channel One of the oscilloscope from test point "BIN" on the "IT" card to the test point "MOB" on the "SP" card. Leave the trigger on this channel with positive slope.
- b) Close switch S1 and slowly reduce voltage  $V_T$  until Channel Two goes low. Alternately raise and lower  $V_T$  and observe the time delay before Channel Two goes low. This time delay is the setting of the "DURATION TIMER" which can be increased by turning potentiometer P8 clockwise.

The logic of the MOB function can then be checked by lowering voltage  $V_T$  until the continuity tester indicates that the main output contacts are closed. Reduce  $V_T$  to approximately 80% of this voltage and open switch S1. Close switch S1 and observe that Channel Two of the oscilloscope does not go low at any time.

## INSTALLATION PROCEDURE

### INTRODUCTION

The relay should be mounted on a vertical surface. The outline and panel drilling diagram is shown in Figure 22.

The location should be clean, dry, free from dust or excessive vibration and well lighted to facilitate inspection and testing.

The internal connection diagrams for the relays are shown in Figures 2 and 3. Typical external connections are shown in Figure 4.

### SURGE GROUND AND RELAY CASE GROUND CONNECTIONS

One of the mounting studs or screws should be permanently connected to ground by a conductor not less than No. 12 AWG gage copper wire or its equivalent. This connection is made to ground the relay case. In addition, Terminal 10 designated as "surge ground" on the internal connections diagram must be tied to ground for the surge suppression networks in the relay to perform properly. This surge ground lead should be as short as possible to ensure maximum protection from surges (preferably ten inches or less to reach a solid ground connection).

With Terminal 10 connected to ground, "surge ground" is connected electrically to the relay case. The purpose of this connection is to

prevent high frequency transient potential differences from entering the solid state circuitry. Therefore, with Terminal 10 connected to ground the surge capacitors are connected between the input terminals and the case. When hipotting the relay, the procedure given in DIELECTRIC TESTS under the ACCEPTANCE TESTS section of this book must be followed.

### TEST PLUGS

The relay may be tested without removing it from the panel by using a 12XLAl3A test plug. This plug makes connections only with the relay and does not disturb any shorting bars in the case. Of course, the 12XLAl2A test plug may also be used. Although this test plug allows greater testing flexibility, it also requires current transformer shorting jumpers and the exercise of greater care since connections are made to both the relay and the external circuitry. Additional information on the XLA test plugs may be obtained from instruction book GEI-25372.

### INSTALLATION TESTS

Since operating companies use many different procedures for installation tests, the section under ACCEPTANCE TESTS contains all necessary tests which may be performed as part of the installation procedure at the discretion of the user.

The minimum suggested tests are as follows:

1. VISUAL INSPECTION

Repeat the items described under ACCEPTANCE TESTS - VISUAL INSPECTION.

2. MECHANICAL INSPECTION AND ADJUSTMENTS

Repeat the items described under ACCEPTANCE TESTS - VISUAL INSPECTION.

3. TARGET UNIT

Set the target unit tap screw in the desired position. The adjustment will not be disturbed if a screw is first transferred from the left plate to the desired tap position on the right tap plate and then removing the screw in the undesired tap and transferring it to the left plate.

4. REACH TESTS

a) Using the values selected in the CALCULATION OF SETTINGS section of this book, set:

- Base reach ( $Z_{R1}$ ) on the back of the relay
- Percent restraint (T) on the front panel potentiometer

b) Measure the relay reach at  $85^\circ$  as described in the ACCEPTANCE TESTS section of this book.

**PERIODIC TESTING AND ROUTINE MAINTENANCE**

In view of the vital role of protective relays in the operation of a power system it is important that a periodic test program be followed. It is recognized that the interval between periodic checks will vary depending upon environment, type of relay and the user's experience with periodic testing. Until the user has accumulated enough experience to select the test interval best suited to his individual requirements it is suggested that the points listed under **INSTALLATION PROCEDURE** be checked at an interval of from one to two years.

Check the items described under **ACCEPTANCE TESTS - VISUAL INSPECTION** and **MECHANICAL INSPECTION**. Examine each component for signs of overheating, deterioration or other damage. Check that all connections are tight by observing that the lockwashers are fully collapsed.

**CONTACTS**

Examine the contacts for pits, arc or burn marks, corrosion, and insulating films. For cleaning contacts, a flexible burnishing tool should be used. This consists of a flexible strip of metal with an etch-roughened surface resembling, in effect, a superfine file. The polishing action is so delicate that no scratches are left, yet it will clean off any corrosion thoroughly and rapidly. Its flexibility ensures the cleaning of the actual points of contact. Do not use knives, files, abrasive paper or cloth of any kind to clean relay contacts.

**CAUTION**

Remove ALL power from the relay before removing or inserting any of the printed circuit boards. Failure to observe this caution may result in damage to and/or misoperation of the relay.

**ELECTRICAL TESTS**

The reach tests described under the **ACCEPTANCE TEST** section should be repeated and the results compared against the desired setting. If the measured value is slightly different from that measured at a previous time, this is not necessarily an indication that the relay should be readjusted. The errors of all the test equipment are often additive and the total error of the present setup may be of opposite sign from the error at the previous periodic test. Instead of readjusting the relay it is recommended that, if the apparent error is acceptable, no adjustment be made and that the error be noted on the relay test record. After sufficient test data has accumulated, it will become apparent whether the measured errors in the setting are due to random variations in the test conditions or are due to a one-time drift in the characteristics of the relay.

SERVICING

A recommended troubleshooting procedure is shown in Table XVIII.

TABLE XVIII

TROUBLESHOOTING PROCEDURE

PROBLEM	PROBABLE CAUSE	TROUBLESHOOTING SEQUENCE
I. Power supply monitor LED is not on.	<ol style="list-style-type: none"> <li>1. Plus and/or minus 15 VDC missing.</li> <li>2. Defective LED, zener diode CR15 or resistor R15.</li> </ol>	<ol style="list-style-type: none"> <li>1. Check +15V and -15V test points on PS card. If either or both voltages are not between 14 and 16 volts check that rated DC voltage (48 or 125 VDC) is on PS card pin 40(+) to pin 24(-). If not, check input terminals 19(+) to 20(-).</li> <li>2. Replace PS card.</li> </ol>
II. Relay will not pick up when it should on any of the three phases but power supply monitor LED is on.	<ol style="list-style-type: none"> <li>1. Defective telephone relay (K2) or target (T1).</li> <li>2. Defective reed relay (K1).</li> <li>3. Defective IT card.</li> </ol>	<ol style="list-style-type: none"> <li>1. Remove PS card and jumper pins 17 and 40 of the PS card. If the relay does not pick up, then K2 or T1 is defective.</li> <li>2. If the relay picks up with the jumper in the preceding step (1) then remove the jumper and reinsert PS card. Remove the CL card and the relay should pick up. If not, K1 relay is possibly defective. Change the PS card.</li> <li>3. If replacing the PS card in the step (2) does not cause pickup (with the CL card still removed) the IT card is possibly defective. Change the IT card.</li> </ol>

TABLE XVIII  
(Continued)  
TROUBLESHOOTING PROCEDURE

PROBLEM	PROBABLE CAUSE	TROUBLESHOOTING SEQUENCE
III. Relay will not pick up when it should on phase BC, but picks up correctly on phases AB and CA (Type SLY81B only).	1. "OSB" plug on the SP card in the "IN" position.	1. Place "OSB" plug in the "OUT" position for reach tests.
IV. Relay will not pick up when it should on one phase, but picks up correctly on another phase.	1. Overcurrent supervision sensitivity set too high.	1. Turn sensitivity potentiometer, on SP card for the inoperative phase (P2 for phase AB, P4 for phase BC or P6 for phase CA) fully counterclockwise.
	2. Defective card.	2. Change printed circuit cards, one at a time, in the following order: IT, CL, SP, CP, OS.
V. Out of specification in maximum reach $\pm 30^\circ$ tests.	1. Incorrect steady state pickup time on IT card.	1. Set steady state pickup time pot and recheck other phases.
	2. Defective card	2. Change printed circuit cards, one at a time, in the following order; SP, CP, IT, CL, OS.

**RENEWAL PARTS**

It is recommended that sufficient quantities of renewal parts be carried in stock to enable the prompt replacement of any that are worn, broken, or damaged.

Should a printed circuit card become inoperative, it is recommended that this card be replaced with a spare. A special tool (see Figure 21) is available for removing the printed circuit cards from their sockets and this tool should always be used for removal. In most instances, the user will be anxious to return the equipment to service as soon as possible and the insertion of a spare card represents the most expeditious means of accomplishing this. The faulty card can then be returned to the factory for repair or replacement.

component on the card which has failed. By referring to the internal connection diagram for the card, it is possible to trace through the card circuit by signal checking and, hence determine which component has failed. This, however, may be time consuming and if the card is being checked in place in this unit, as is recommended, will extend the outage time of the equipment.

**CAUTION**

Great care must be taken in replacing components on the cards. Special soldering equipment suitable for use on the delicate solid-state components must be used and, even then, care must be taken not to cause thermal damage to the components, and not to damage or bridge over the printed circuit buses. The repaired area must be recoated with a suitable high di-electric plastic coating to prevent possible breakdowns across the printed circuit buses due to moisture of dust.

**ADDITIONAL CAUTION**

Dual in-line integrated circuits are especially difficult to remove and replace without specialized equipment. Furthermore, many of these components are used on printed circuit cards which have bus runs on both sides. These additional complications require very special soldering equipment and removal tools as well as additional skills and training which must be considered before field repairs are attempted.

When ordering renewal parts, address the nearest Sales Office of the General Electric Company, specify quantity required, name of the part wanted, and the complete model number of the relay for which the part is required.

Since the last edition, changes have been made in the ANSI reference under RATING GENERAL; in Table IV; in the Detailed Testing Instructions for Relay Base Reach Angle and Reach Check, for Testing Mho Characteristics, for Integrating Timer Tests, and for Overcurrent Supervision Tests; and in Figures 18A and 22. Other figure captions have been updated.

APPENDIX I

DEFINITION OF SYMBOLS

$I_A$	=	total phase A current in relay in amperes rms
$I_B$	=	total phase B current in relay in amperes rms
$I_C$	=	total phase C current in relay in amperes rms
$I_T$	=	relay current during test in amperes rms
$T$	=	relay voltage restraint setting in percent
$V_{AB}$	=	phase A to phase B voltage in volts rms
$V_{BC}$	=	phase B to phase C voltage in volts rms
$V_{CA}$	=	phase C to phase A voltage in volts rms
$V_{AB1}$	=	positive sequence of $V_{AB}$ voltage in volts rms
$V_{BC1}$	=	positive sequence of $V_{BC}$ voltage in volts rms
$V_{CA1}$	=	positive sequence of $V_{CA}$ voltage in volts rms
$V_T$	=	relay voltage during test in volts rms
$Z_1$	=	system positive sequence phase to neutral impedance in ohms
$Z_{1L}$	=	line positive sequence phase to neutral impedance in ohms
$Z_{1S}$	=	source positive sequence phase to neutral impedance in ohms
$Z_{2L}$	=	line negative sequence phase to neutral impedance in ohms
$Z_{2S}$	=	source negative sequence phase to neutral impedance in ohms
$Z_F$	=	system impedance between relay location and fault location in ohms
$Z_R$	=	relay reach in ohms
$Z_{R1}$	=	base reach tap in positive sequence ohms
$\alpha$	=	phase angle meter reading during test in degrees
$\phi$	=	relay base reach angle in degrees

## APPENDIX II

In the event that the SLY81 operating time is desired for a specific fault location, the average operating time can be obtained from Figure 28. The operating time can be obtained from the appropriate curve by calculating the equivalent voltage applied to the operating circuit by means of the formula  $(I_A - I_B) (Z_{R1} - TZ_{IF})$ . The relay incorporates a filter delay for faults near the balance point to preclude overreach on CCVT transients. Hence, the pre-fault energy in the filter will influence the operating time on lighter faults. The upper curve is appropriate for restraint settings of 40% or higher, the middle curve for 20% restraint setting, and the lower curve for 10% restraint setting. Speed for restraint settings between 10% and 20%, and 20% and 40% can be estimated by interpolation.

The data is plotted for the following conditions;

- (a) Integrating timer set for 5.5, 4.2/5 milliseconds (50 hertz - 6.6, 5/6 milliseconds)
- (b) No load in the relay prior to the fault
- (c) The source and fault impedance have approximately the same impedance angle as the relay maximum reach.

Heavy pre-fault load flow in the relay can result in much shorter operating times for close-in faults, and hence these curves should not be used to establish a minimum operating time.

## Example

Assume the operate time is desired for a fault on the line shown below for the first and second zone relays at the left end. This example illustrates calculations for faults in the middle of the line and at the two ends. The operating times are appropriate for one phase-to-phase measurement unit for phase-to-phase, phase-to-phase-to-ground, and three phase faults. However, the operating time on three phase faults will be slightly faster than for the other two types, since all three units are operating, and the speed will be determined by the fastest measurement unit of the three.



Zone 1 relay setting =

$$0.9(6) = 5.4\Omega; \quad Z_{R1} = 3\Omega; \quad T = \frac{3}{5.4} = 0.56$$

Zone 2 relay setting =

$$1.75(6) = 10.5\Omega; \quad Z_{R1} = 3\Omega; \quad T = \frac{3}{10.5} = 0.29$$

For Fault at F1

$$I_{3\phi} = \frac{115}{\sqrt{3}} \times \frac{1}{1.5 + 3} = 14.75 \text{ Amps}, \quad I_A - I_B = \sqrt{3}(14.75) = 25.5 \text{ Amps}$$

For Zone 1  $(I_A - I_B)(Z_{R1} - TZ_F) = 25.5(3 - 0.56 \times 3) = 33.7$  volts  
From upper curve, time = 14.0 milliseconds

For Zone 2  $(I_A - I_B)(Z_{R1} - TZ_F) = 25.5(3 - 0.29 \times 3) = 54.3$  volts

Interpolating between the upper and middle curve,  
Time = 10.5 milliseconds

For fault at F2

$$I_{3\phi} = \frac{115}{\sqrt{3}} \times \frac{1}{1.5} = 44.3 \text{ Amps}, \quad I_A - I_B = \sqrt{3}(44.3) = 76.7 \text{ Amps}$$

For Zone 1  $(I_A - I_B)(Z_{R1} - TZ_F) = 76.6(3 - 0.56 \times 0) = 230$  volts  
From upper curve time = 10.5 milliseconds

For Zone 2  $(I_A - I_B)(Z_{R1} - TZ_F) = 76.6(3 - 0.29 \times 0) = 230$  volts  
By interpolation time = 10.5 milliseconds

For Fault at F3

$$I_{3\phi} = \frac{115}{\sqrt{3}} \times \frac{1}{1.5 + 6} = 8.85 \text{ Amps}, \quad I_A - I_B = \sqrt{3}(8.85) = 15.3 \text{ Amps}$$

For Zone 1  $(Z_{R1} - TZ_F)$  is negative, relay does not operate

For Zone 2  $(I_A - I_B)(Z_{R1} - TZ_F) = 15.3(3 - 0.29 \times 6) = 19.3$  volts  
By interpolation, time = 16.0 milliseconds

LIST OF ILLUSTRATIONS

<u>Figure</u>	<u>Page</u>
1 Functional Block Diagram . . . . .	35
2 Internal Connections for Type SLY81A . . . . .	36
3 Internal Connections for Type SLY81B . . . . .	37
4 External Connections . . . . .	38
5 Rear View of Long Reach Model Out of Case . . . . .	39
6 Front View of Relay Out of Case . . . . .	40
7 Restraint Setting Dial (Set at 84%) . . . . .	41
8 Measurement Principle . . . . .	41
9A Average Operating Time for First Zone Relay - 60 hertz . .	42
9B Average Operating Time for First Zone Relay - 50 hertz . .	42
10A Average Operating Time for Second Zone Relay - 60 hertz .	43
10B Average Operating Time for Second Zone Relay - 50 hertz .	43
11 Reach Versus Faulted Phase Voltage . . . . .	44
12A Internal Connections for Type SLY81A Signal Processing Card	45
12B Card Layout for Type SLY81A Signal Processing Card . . . .	46
13A Internal Connections for Type SLY81B Signal Processing Card	47
13B Card Layout for Type SLY81B Signal Processing Card . . . .	47
14A Internal Connections fro 60 Hertz Combined Polarizing Card	48
14B Internal Connections for 50 Hertz Combined Polarizing Card	48
14C Card Layout for Combined Polarizing Card . . . . .	49
15A Internal Connections for 60 Hertz Operate Signal Card . .	49
15B Internal Connections for 50 Hertz Operate Signal Card . .	50
15C Card Layout for Operate Signal Card . . . . .	51
16A Internal Connections for Coincidence Logic Card . . . . .	52
16B Card Layout for Coincidence Logic Card . . . . .	53
17A Internal Connections for Integrating Timer Card . . . . .	54
17B Card Layout for Integrating Timer Card . . . . .	54
18A Internal Connections for 125 Volt DC Rated Input Power Supply . . . . .	55
18B Internal Connections for 110 Volt DC Rated Input Power Supply . . . . .	56
18C Card Layout for 110-125 Volt Rated Input Power Supply Card	57
19A Internal Connections for 48 Volt DC Rated Input Power Supply	58
19B Card Layout for 48 Volt DC Rated Input Power Supply Card .	58
20 Cradle Block and Terminal Block Cross Section . . . . .	59
21 Printed Circuit Card Extracting Tool . . . . .	59
22 Outline and Panel Drilling for Type SLY81A Relay . . . . .	60
23 Front View of Relay Out of Case with Nameplate Removed . .	61
24 Test Circuit for Reach Tests . . . . .	62
25 Characteristic Test Circuit using Test Box, Reactor & Resistor . . . . .	63
26 Timer Card Test Circuit . . . . .	64
27 Test Circuit for MOB test . . . . .	65
28A Operating Time of 60 Hertz Relay Vs. Signal into Operating Circuit . . . . .	66
28B Operating Time of 50 Hertz Relay Vs. Signal into Operating Circuit . . . . .	66
29 Internal Connections Diagram of Pre-Regulator . . . . .	67
30 Outline and Mounting Dimensions of Pre-Regulator . . . . .	68
31 Test Circuit for Characteristic Test . . . . .	69

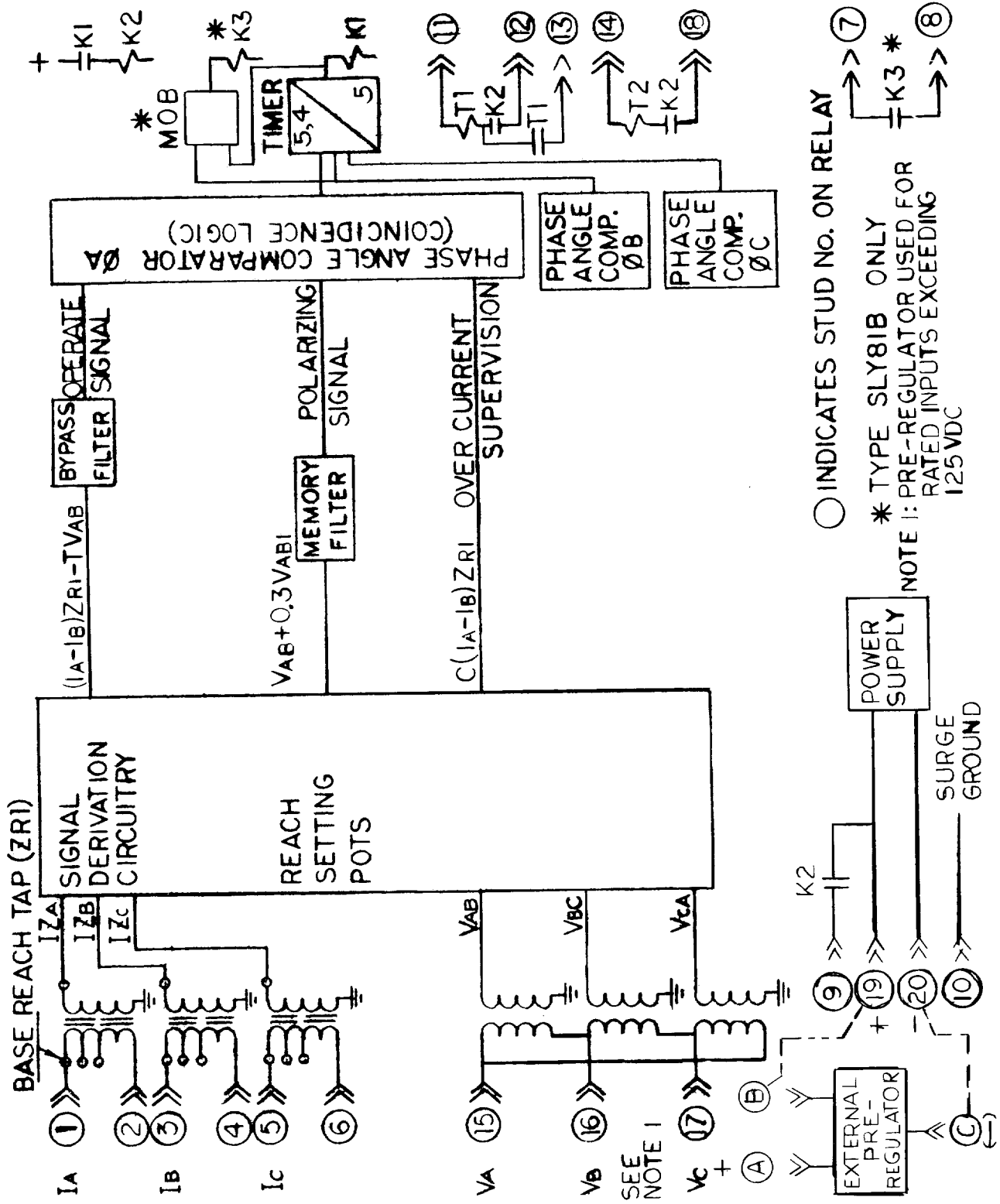

Figure 1 (0273A9091-1) Functional Block Diagram

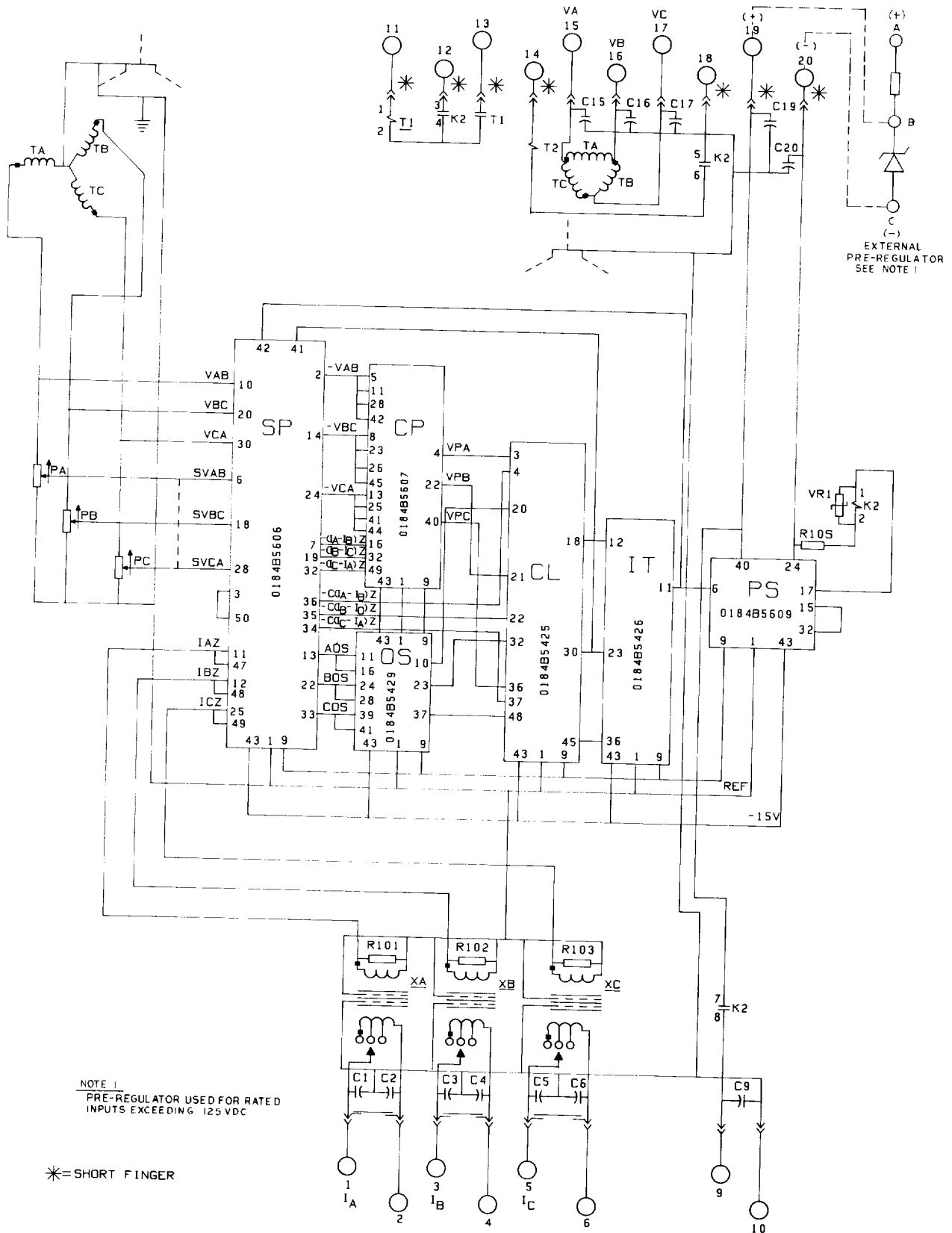

Figure 2 (0152C8489-2) Internal Connections for Type SLY81A

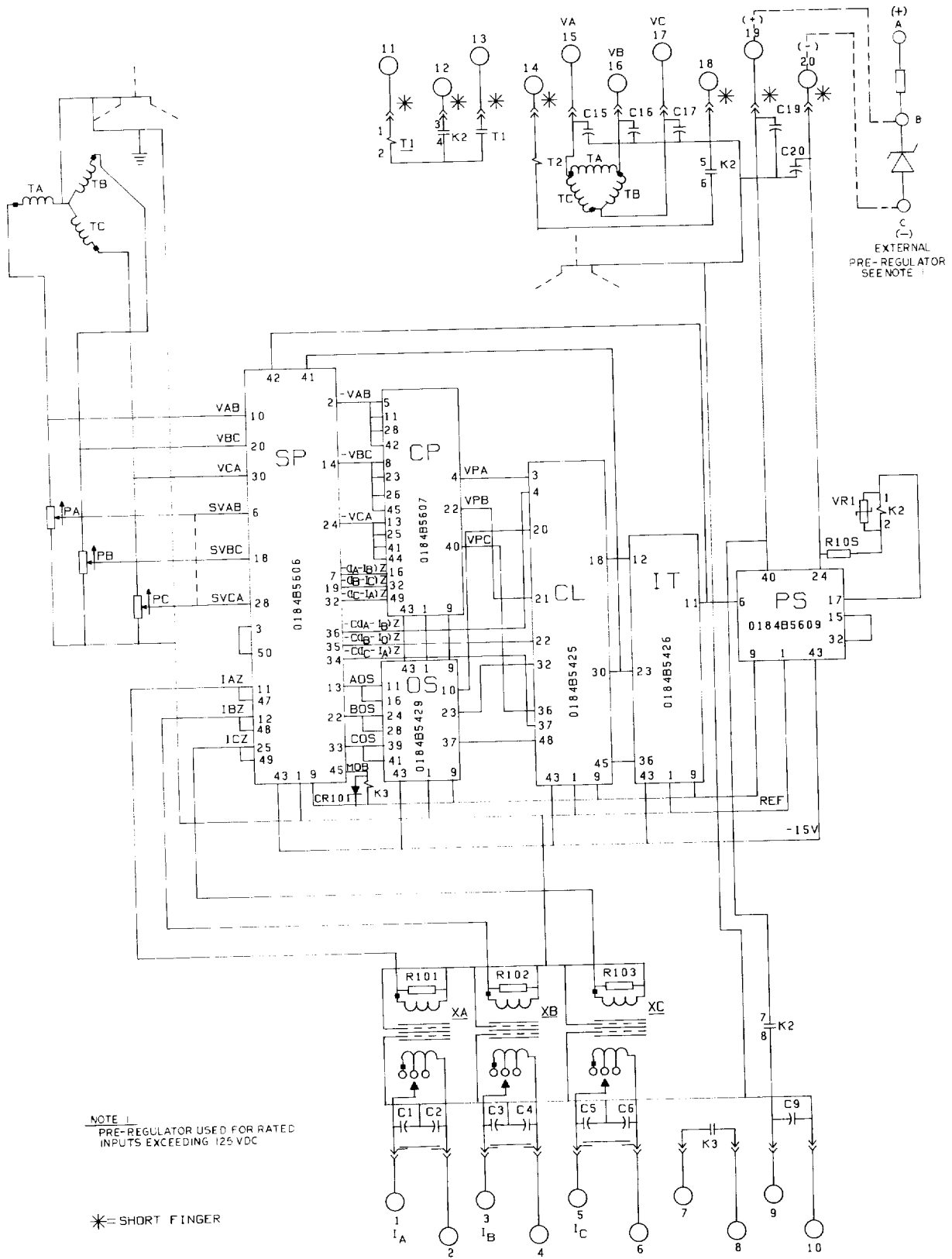
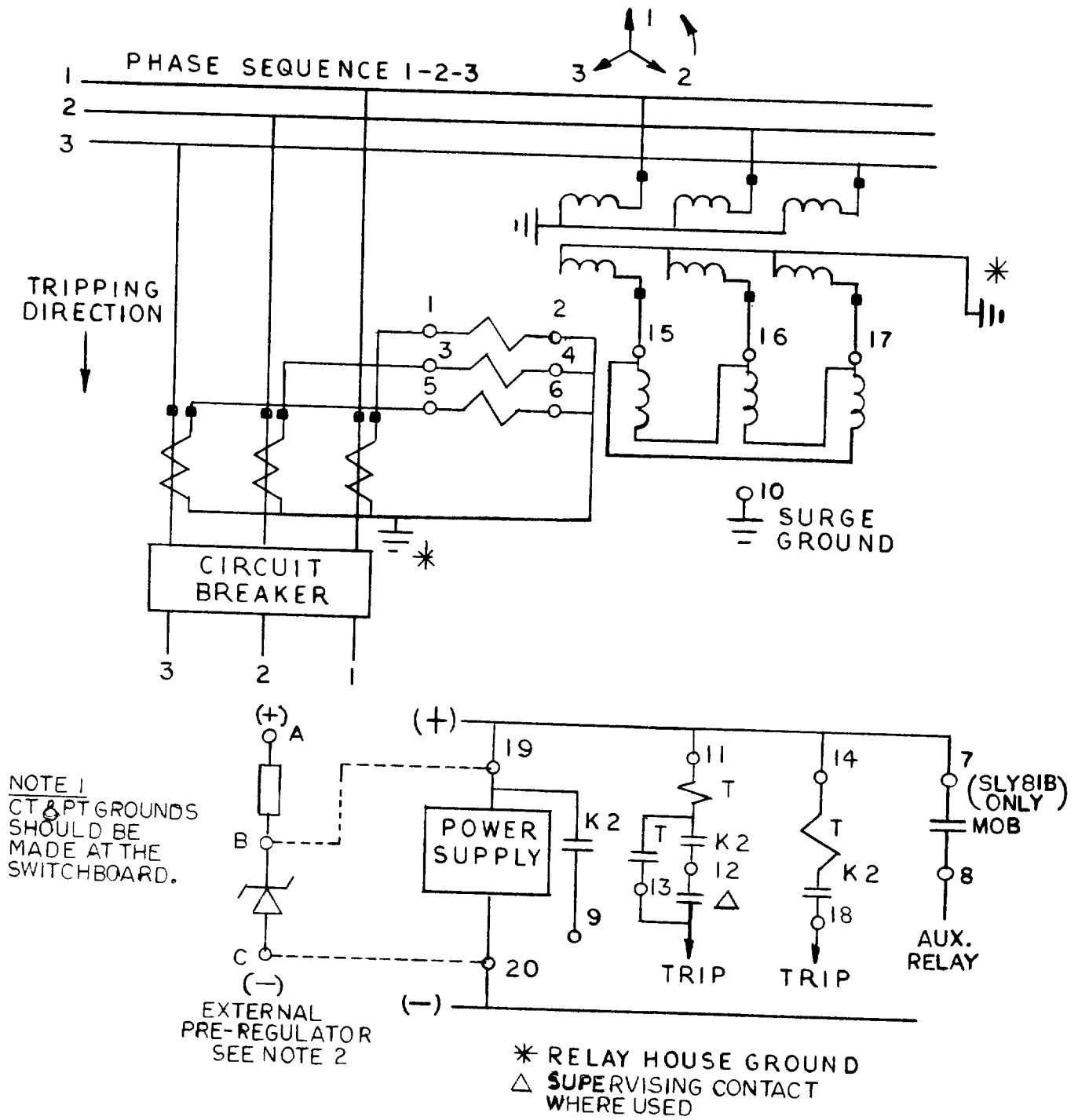

Figure 3 (0152C8461-1) Internal Connections for Type SLY81B



NOTE 1  
CT & PT GROUNDS  
SHOULD BE  
MADE AT THE  
SWITCHBOARD.

EXTERNAL  
PRE-REGULATOR  
SEE NOTE 2

\* RELAY HOUSE GROUND  
Δ SUPERVISING CONTACT  
WHERE USED

NOTE 2  
PRE-REGULATOR USED FOR RATED INPUTS EXCEEDING 125VDC

Figure 4 (0273A9092-2) External Connections

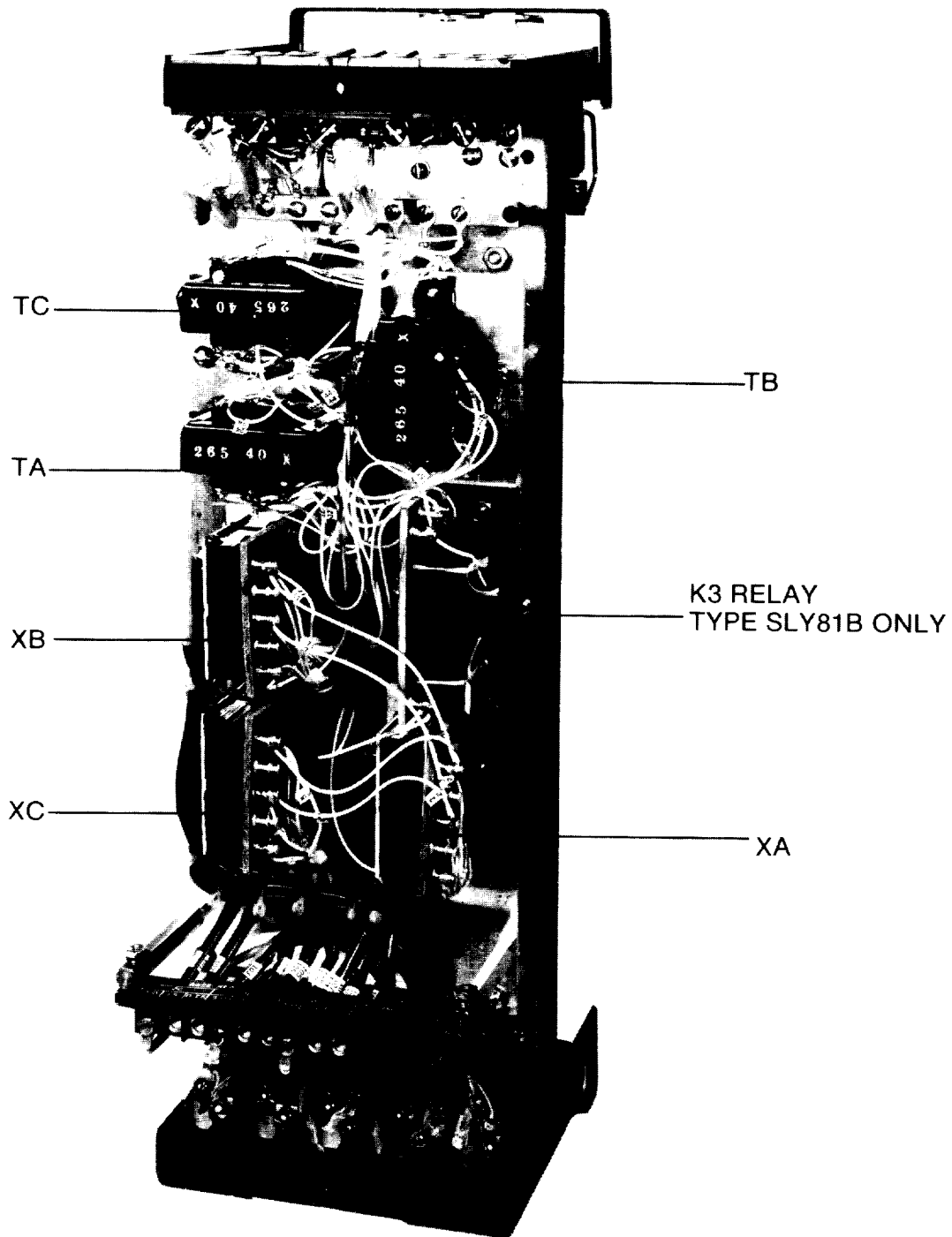

Figure 5 (8043542) Rear View of Long reach Model Out of Case

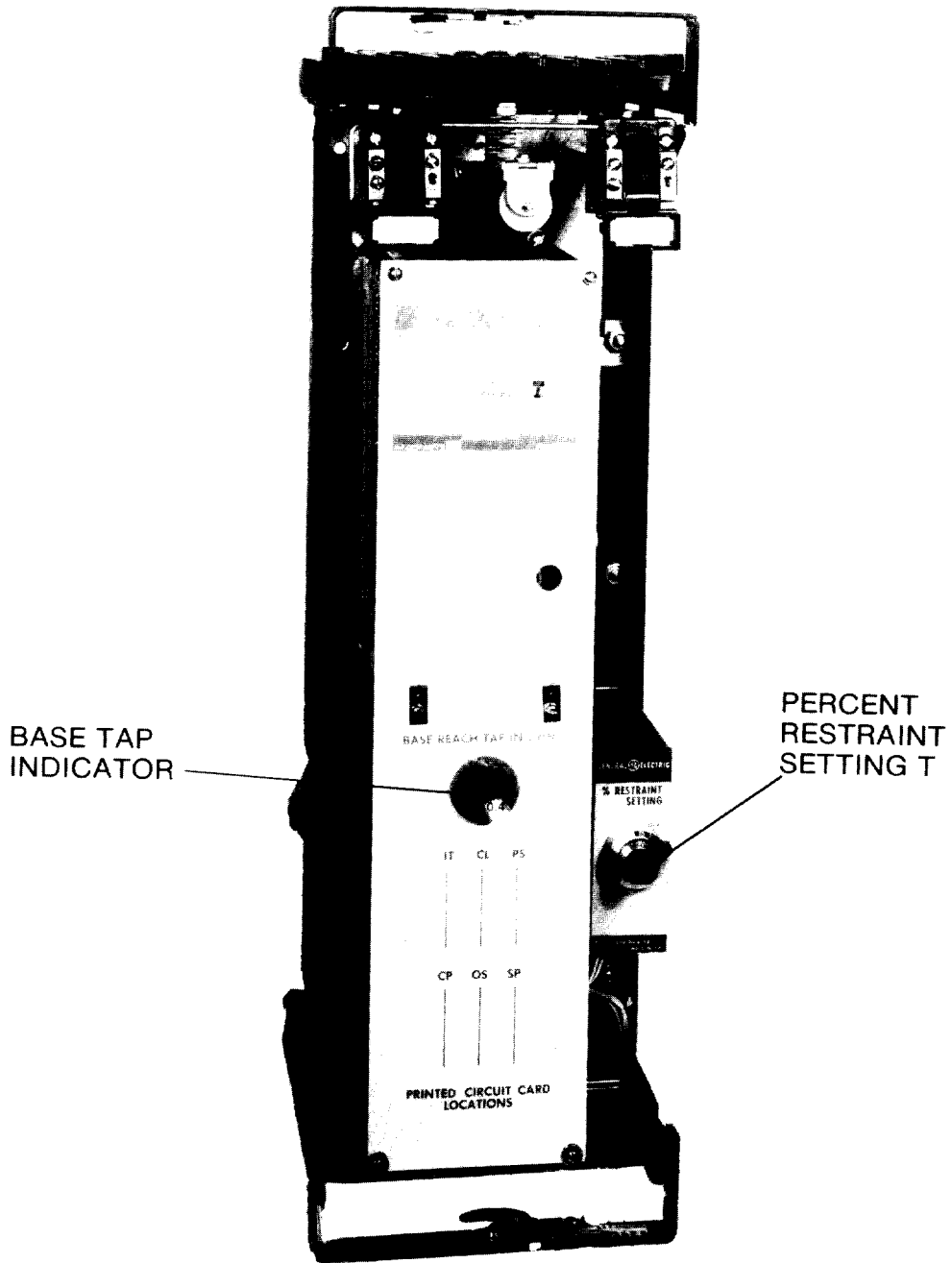

Figure 6 (8043540) Front View of Relay Out of Case



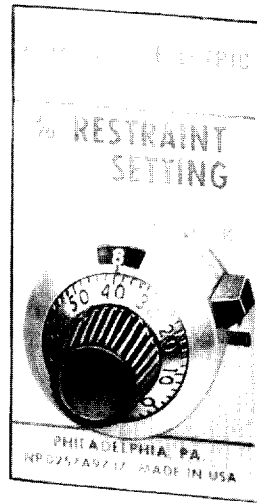

Figure 7 (8042986) Restraint Setting Dial (Set at 84%)

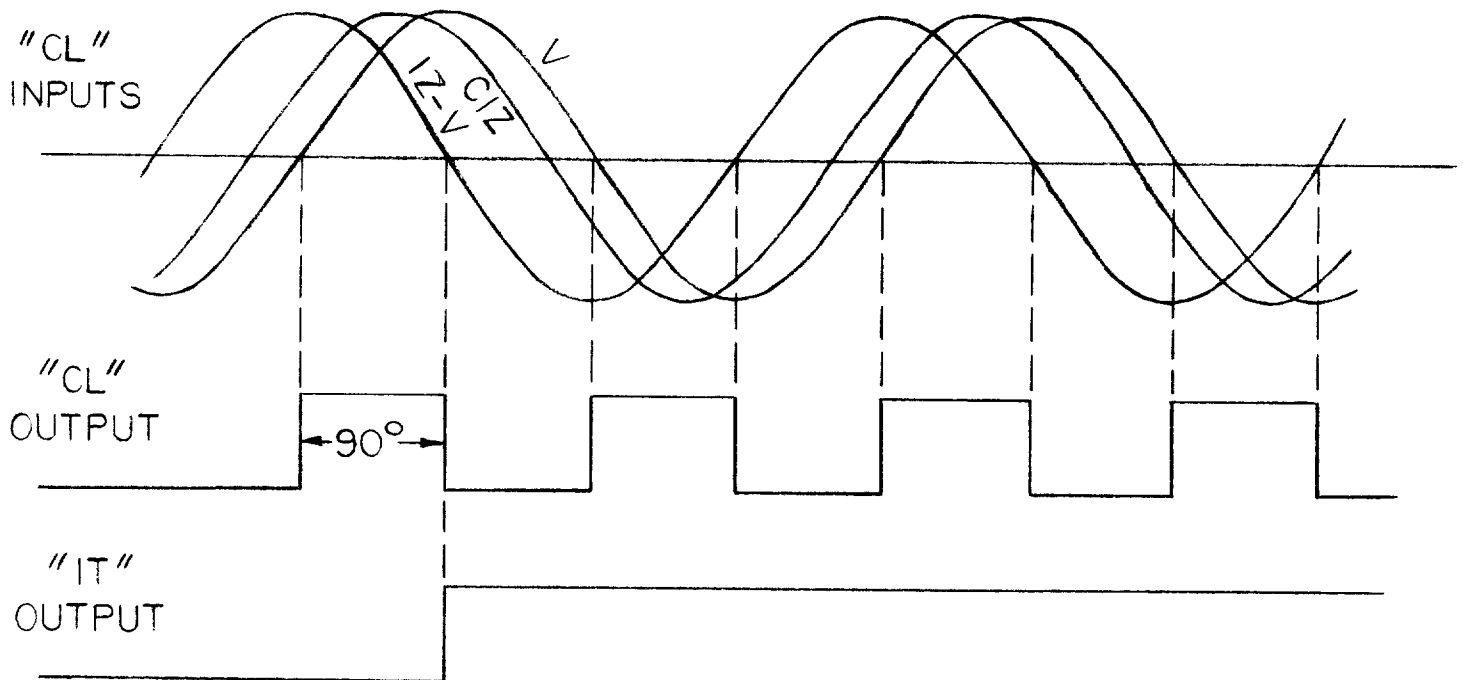

Figure 8 (0273A9093-1) Measurement Principle

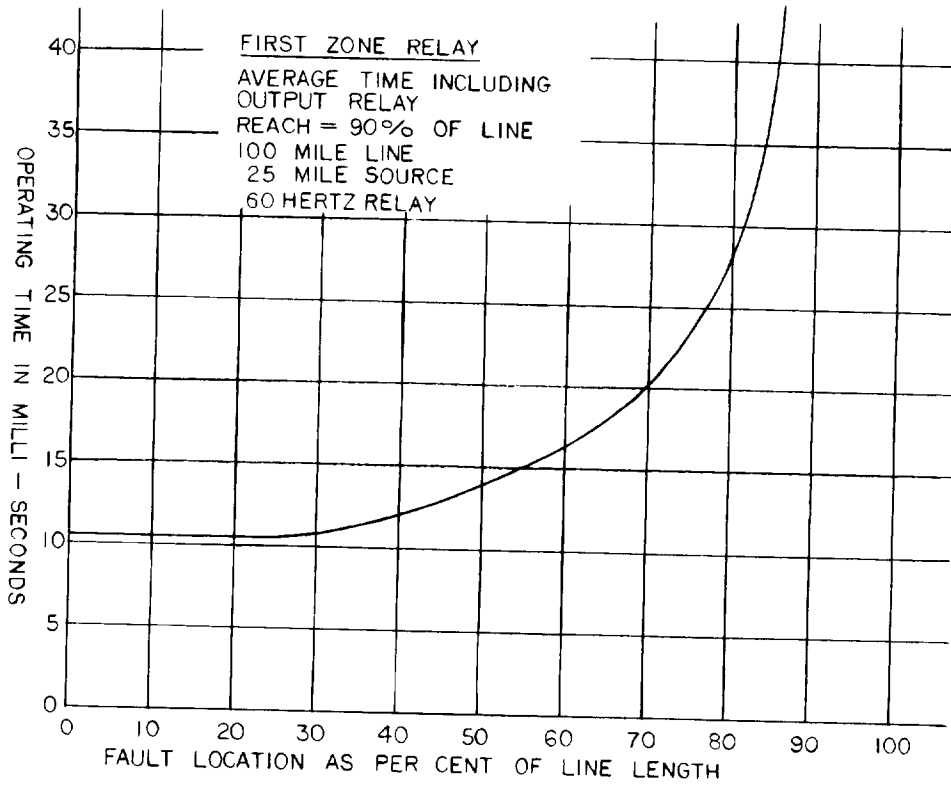

Figure 9A (0273A9094-2 Sh.1) Average Operating Time for First Zone Relay - 60 Hertz

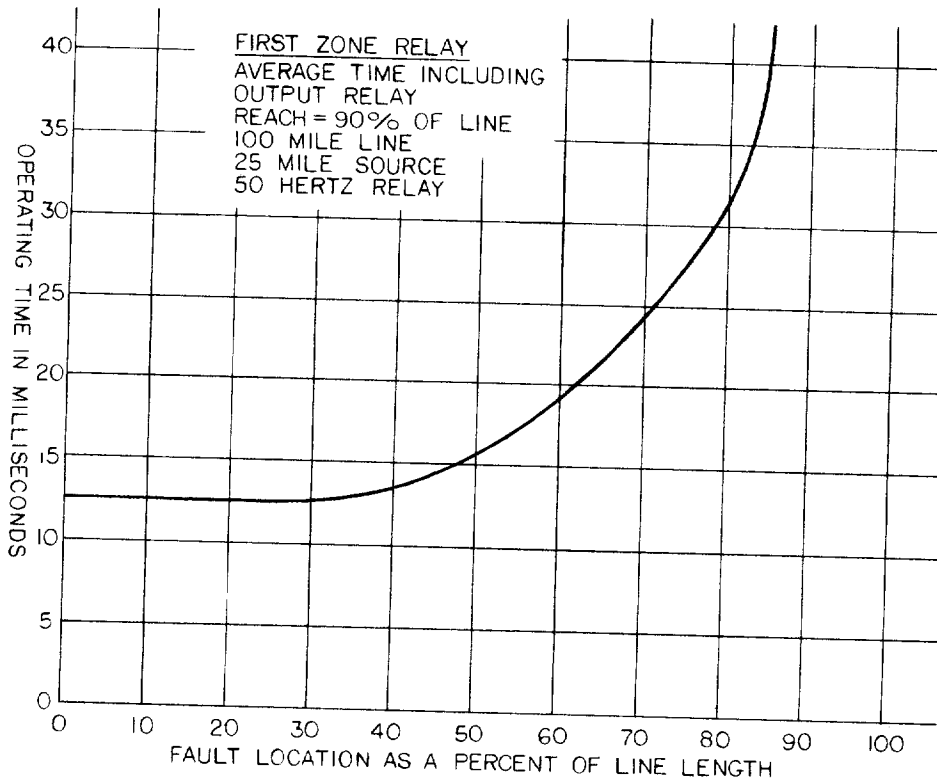

Figure 9B (0273A9094 Sh.2) Average Operating Time for First Zone Relay - 50 Hertz

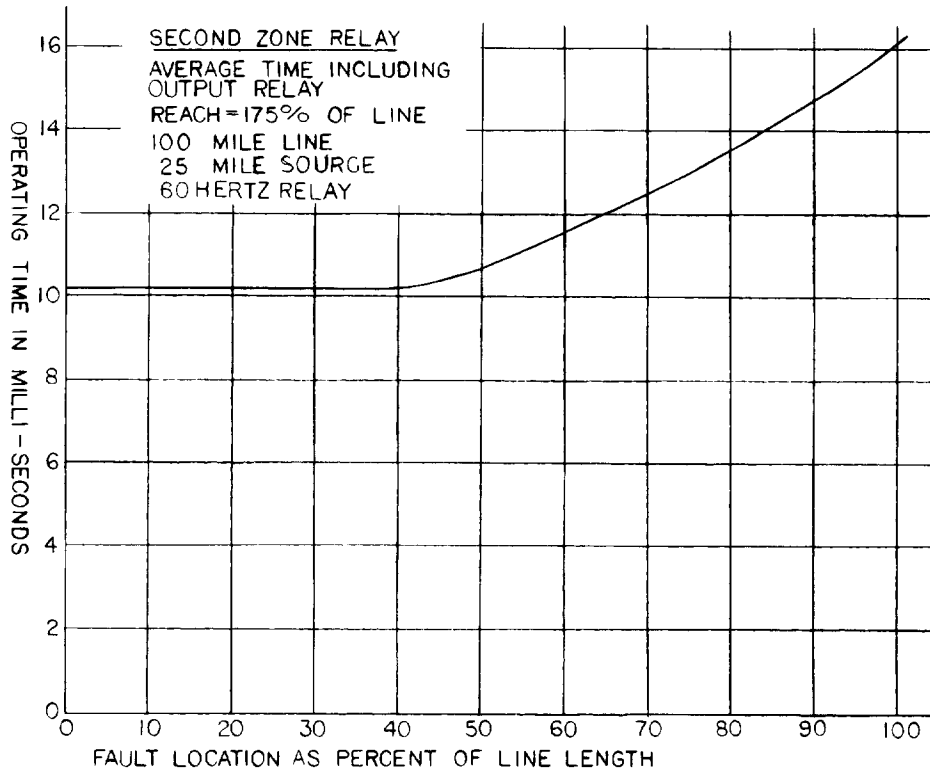

Figure 10A (0273A9095-3 Sh.1) Average Operating Time for Second Zone Relay - 60 Hertz

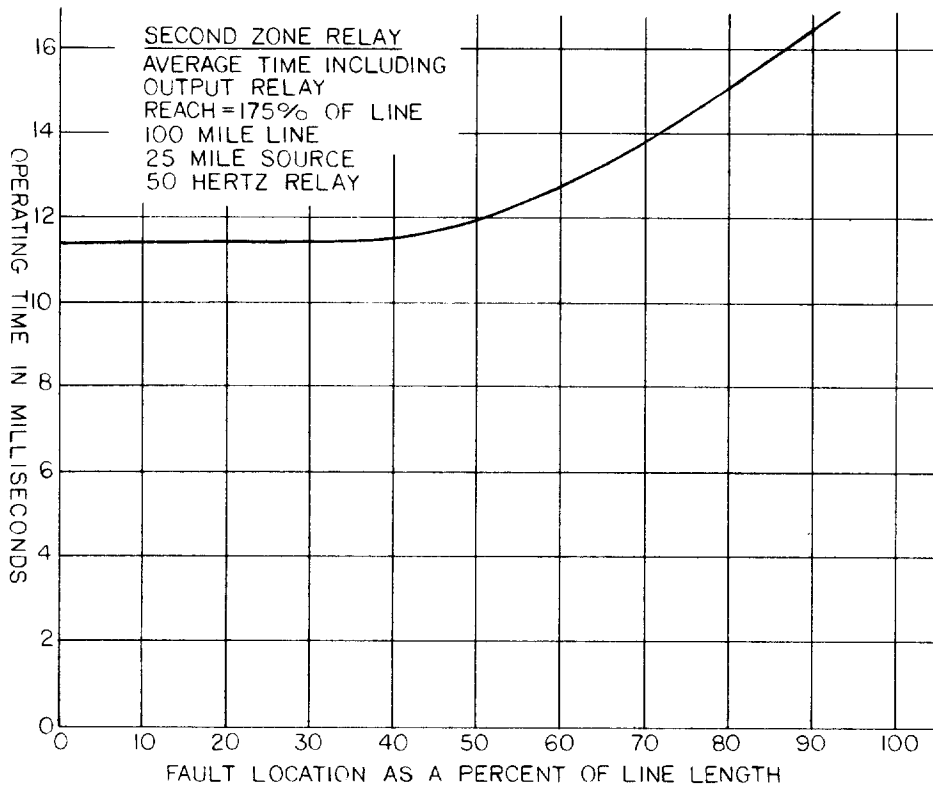

Figure 10B (0273A9095 Sh.2) Average Operating Time for Second Zone relay - 50 Hertz

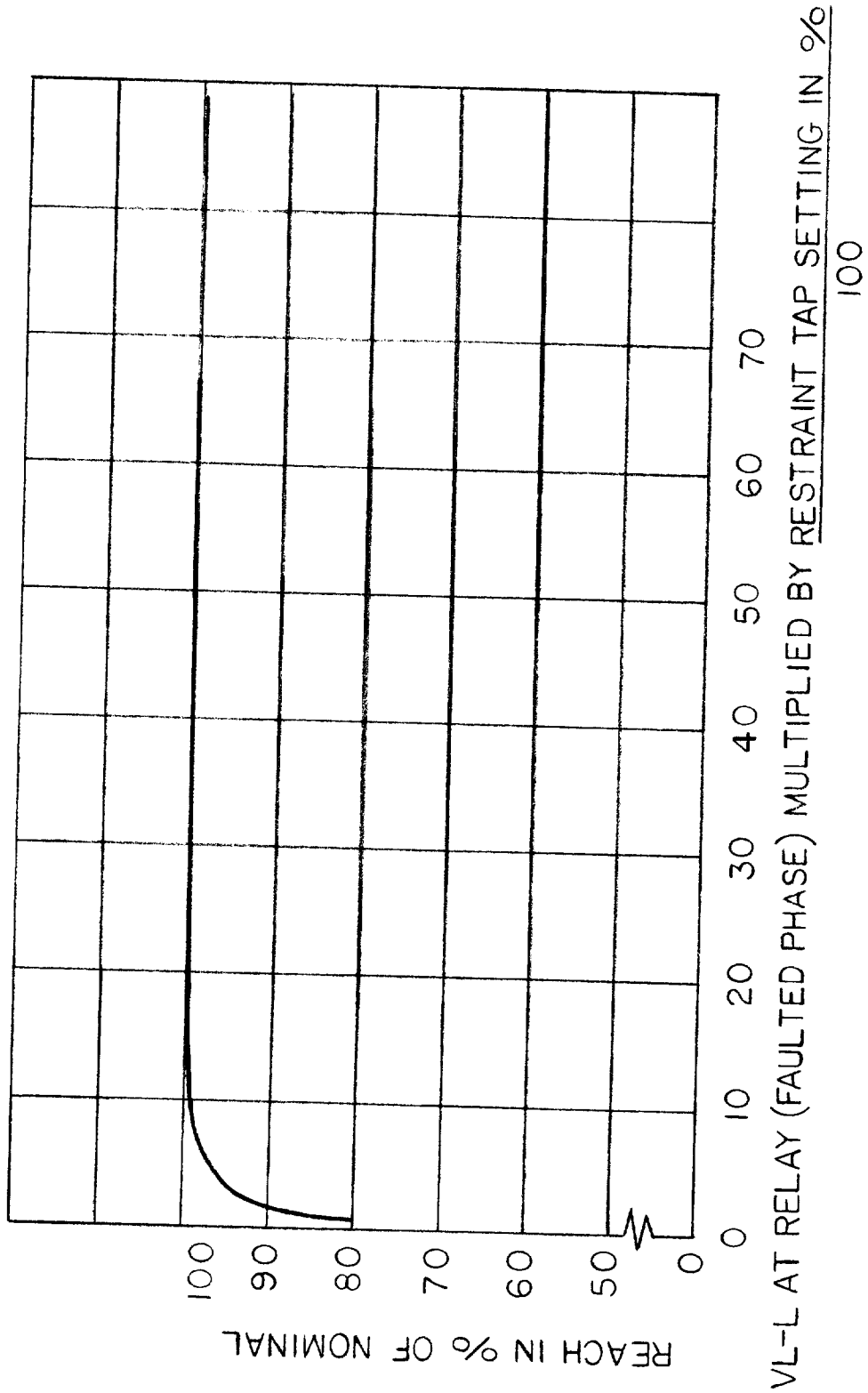

Figure 11 (0273A9096) Reach Versus Faulted Phase Voltage

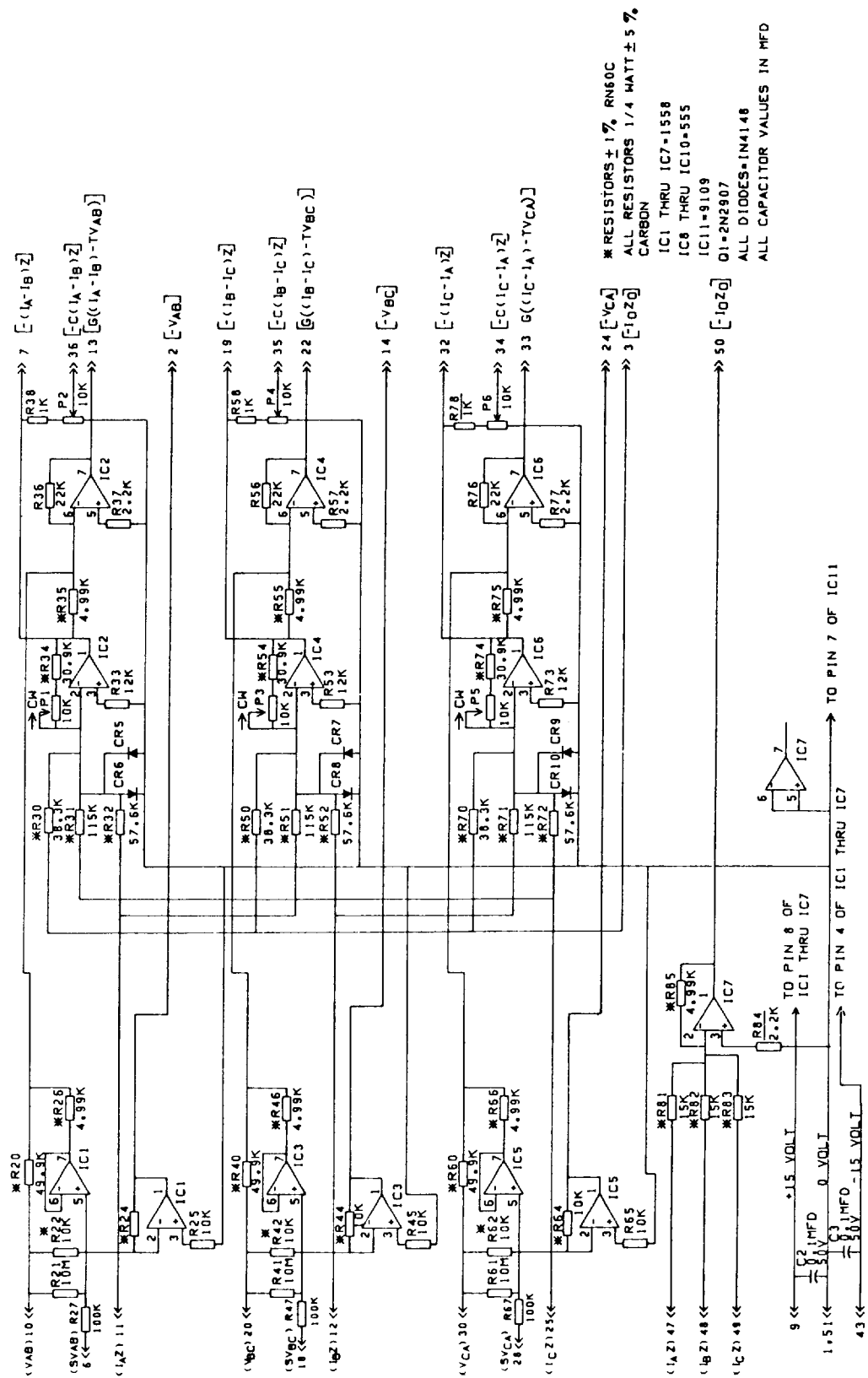

Figure 12A (0152C8463 Sh.3 [1]) Internal Connections for Type SLY81A Signal Processing Card (SP)

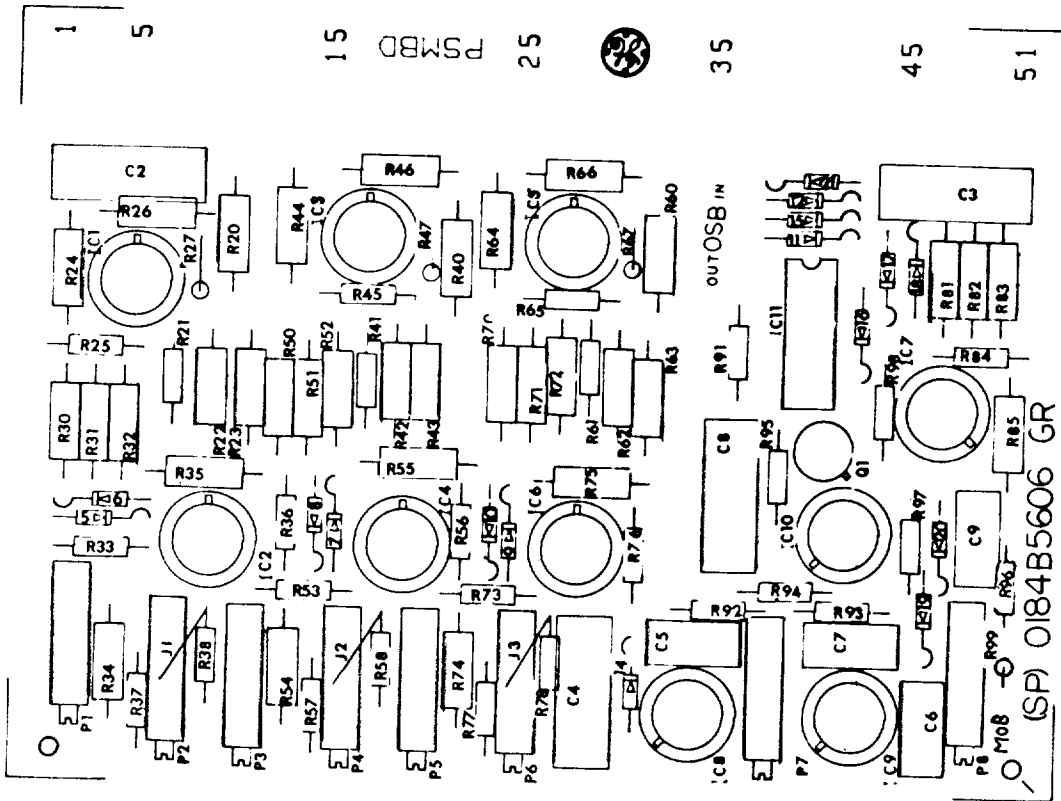

Figure 12B (0171C8706 [8]) Card Layout for Type SLY81A Signal Processing Card (SP)

GEK-49861

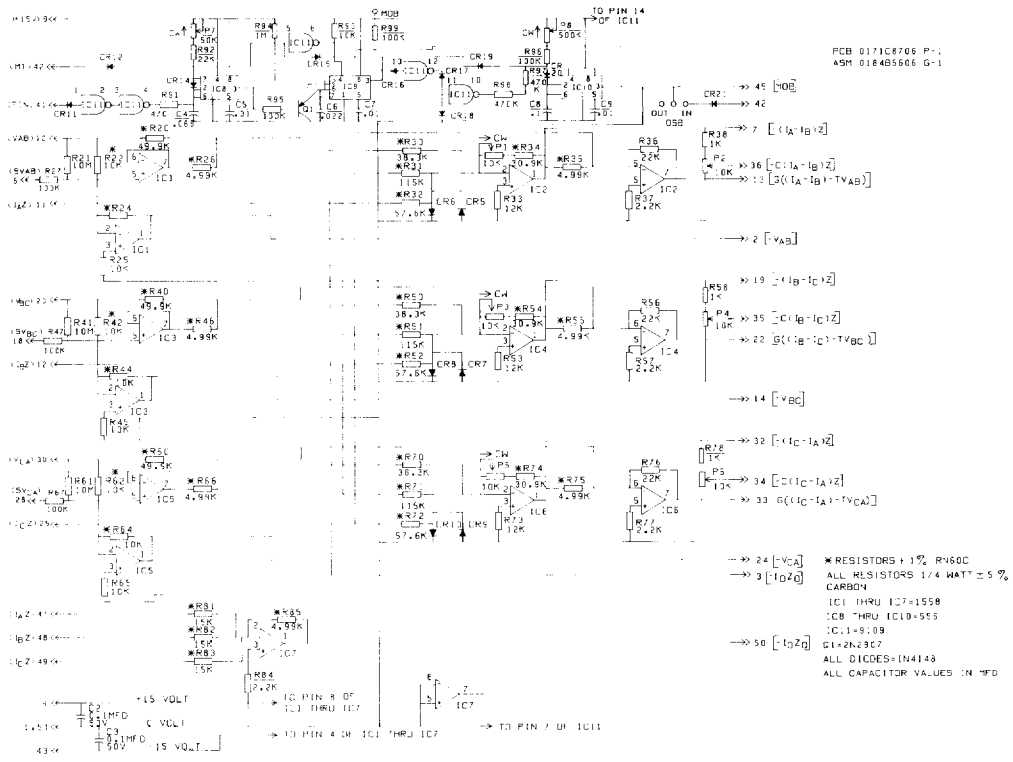

Figure 13A (0152C8463 Sh.1) Internal Connections for Type SLY81B Signal Processing Card (SP)

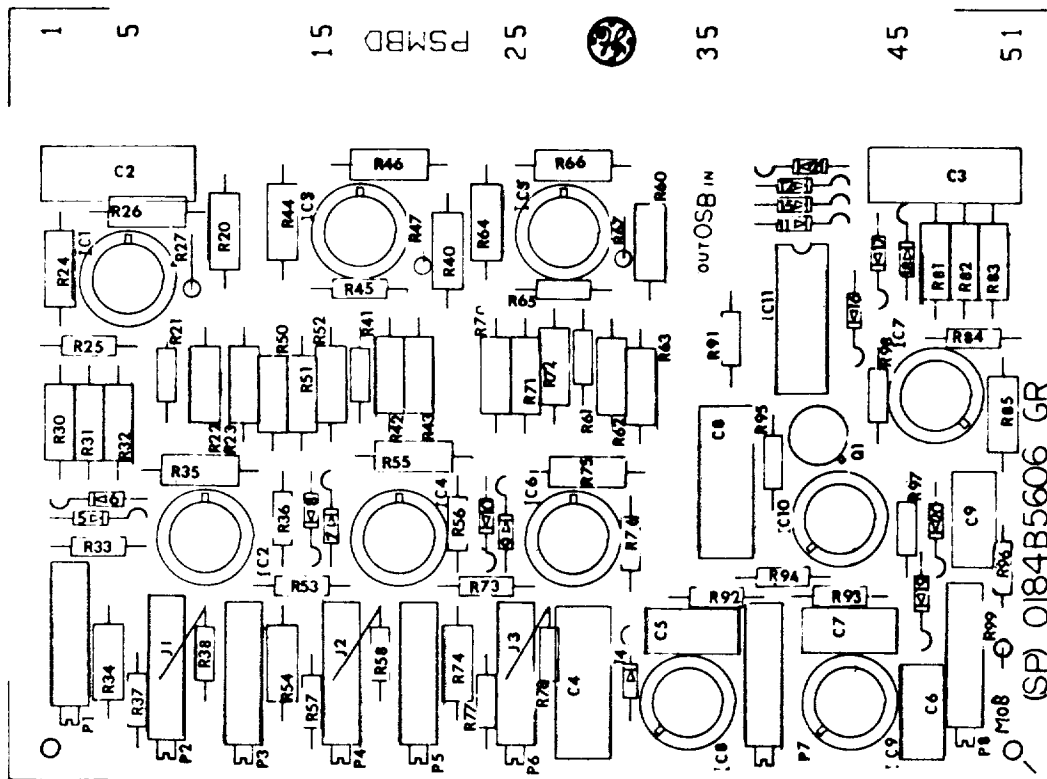

Figure 13B (0171C8706 [8]) Card Layout for Type SLY81B Signal Processing Card (SP)

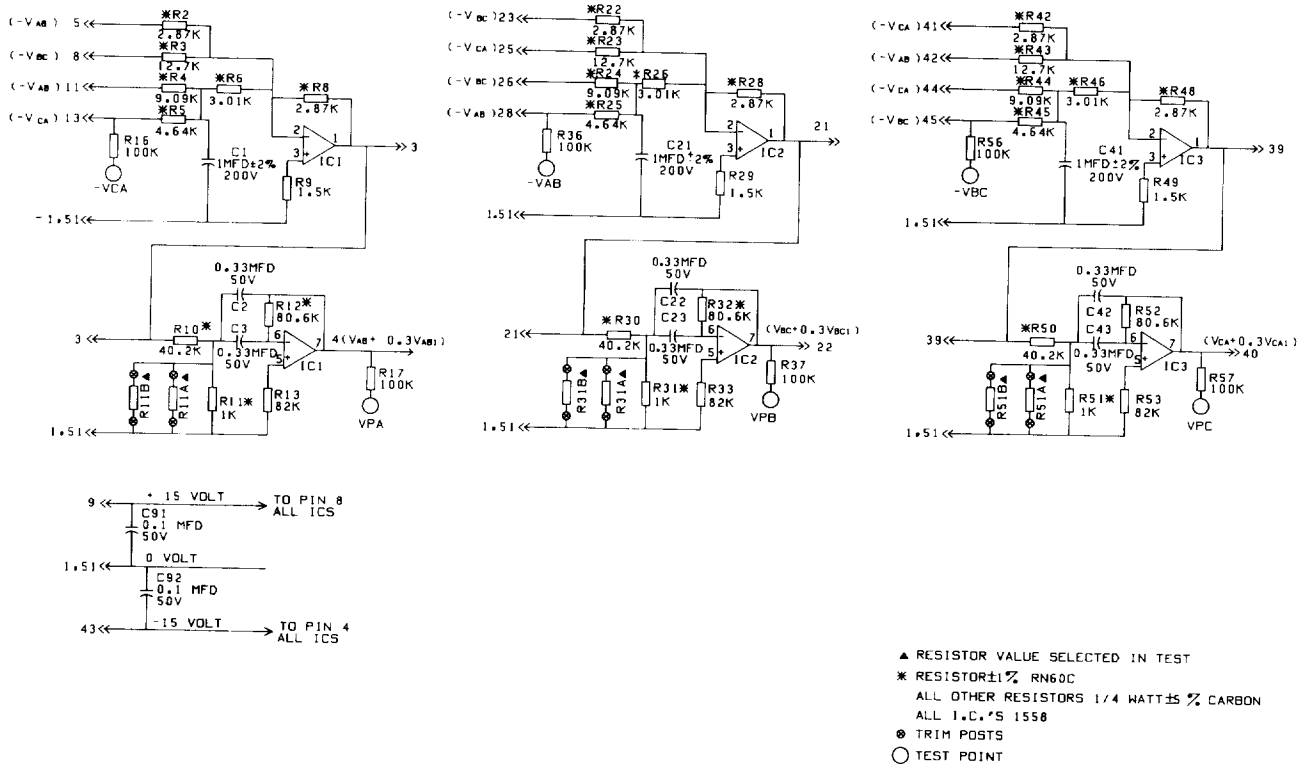

Figure 14A (0152C8464 Sh.1) Internal Connections for 60 Hertz Combined Polarizing Card (CP)

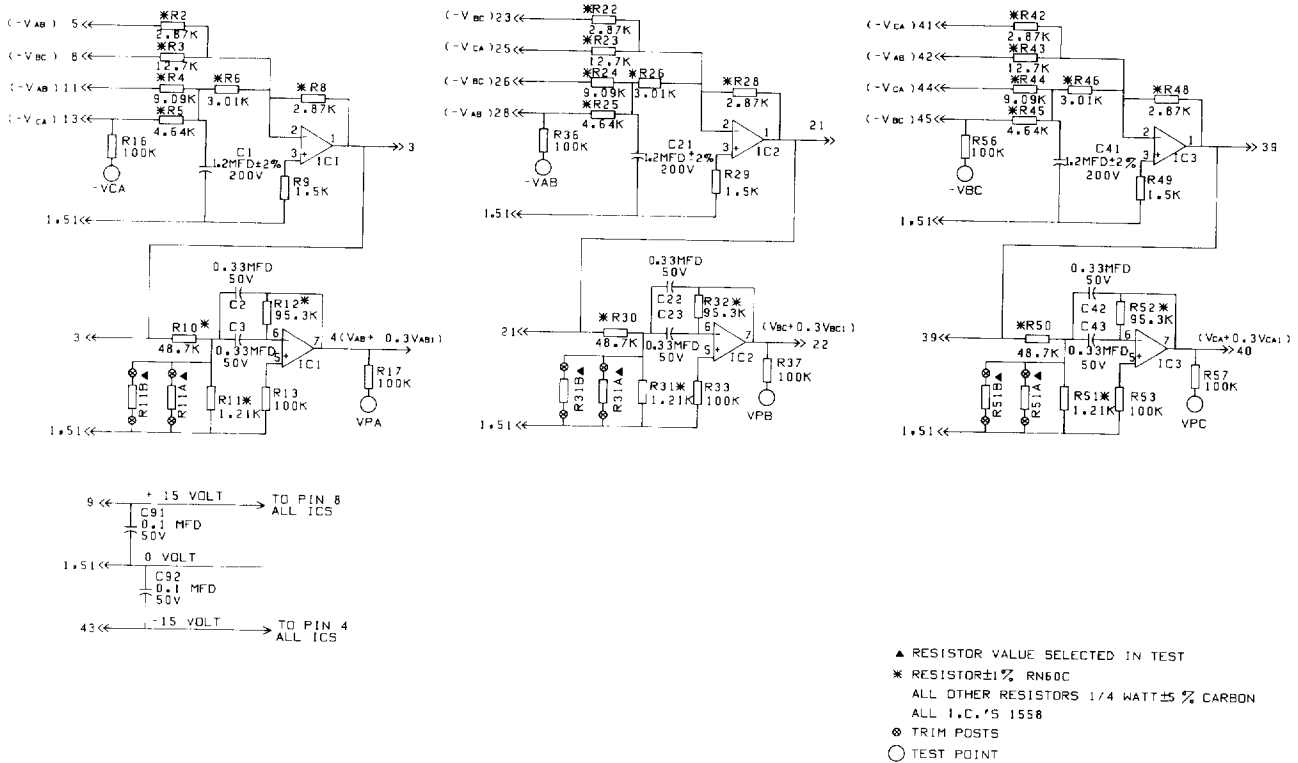

Figure 14B (0152C8464 Sh.3) Internal Connections for 50 Hertz Combined Polarizing Card (CP)



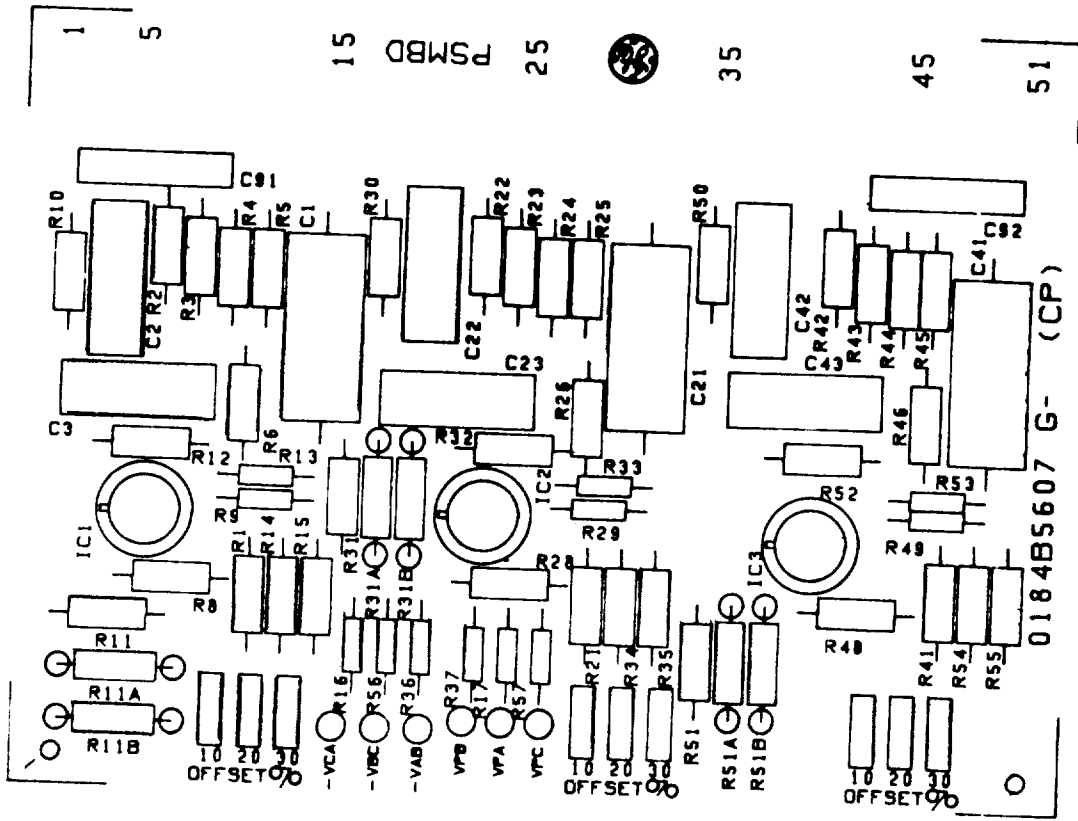

Figure 14C (0171C8707) Card Layout for Combined Polarizing Card (CP)

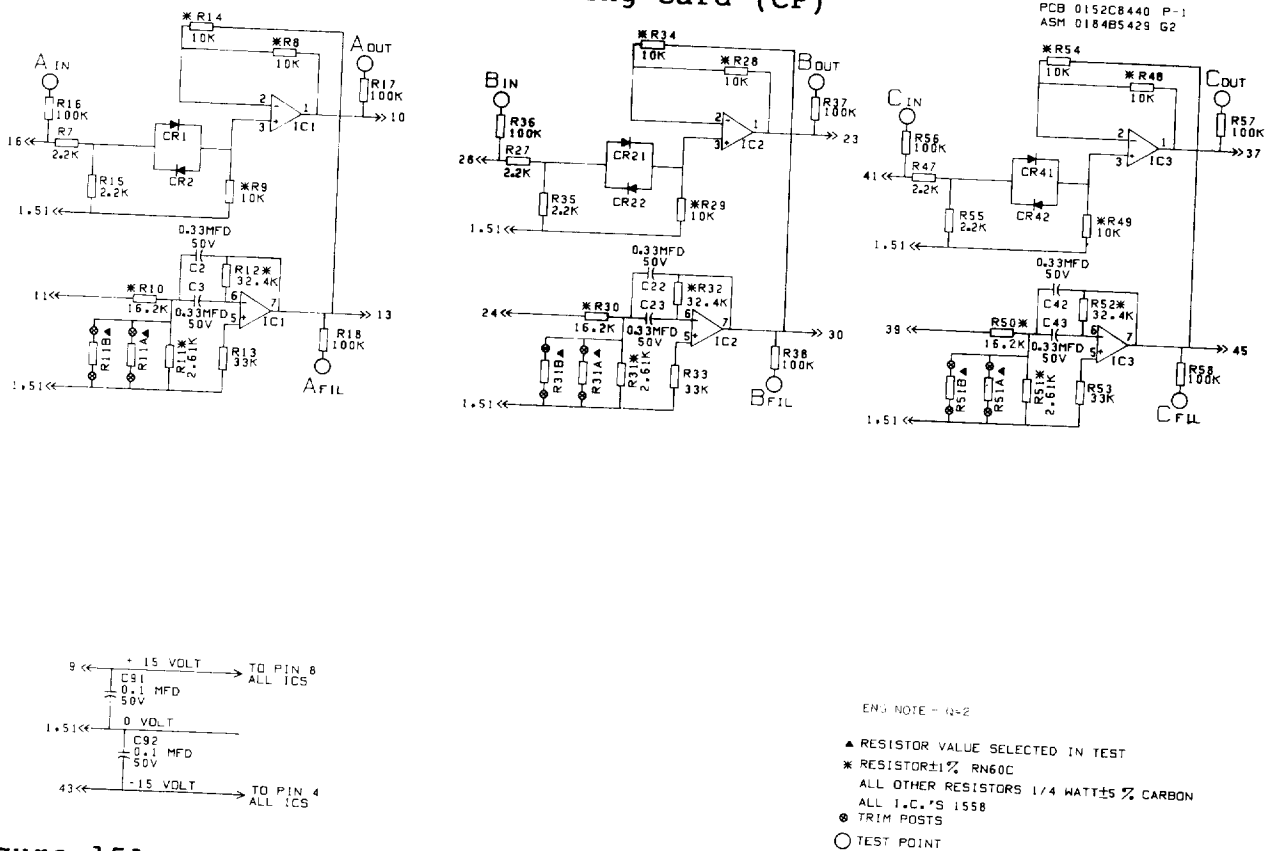
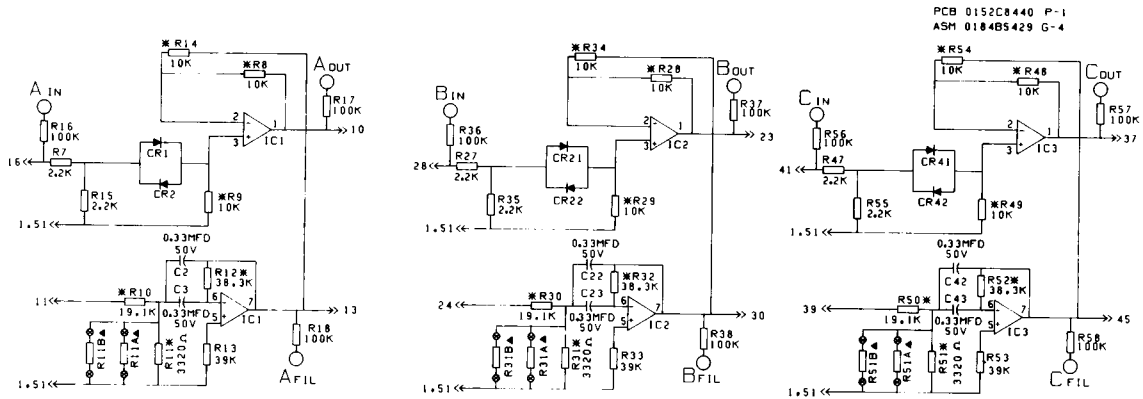
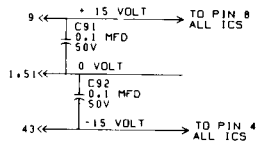

Figure 15A (0152C9087 Sh.2 [1]) Internal Connections for 60 Hertz Operate Signal Card (OS)



ENG NOTE - Q-2



- ▲ RESISTOR VALUE SELECTED IN TEST
- \* RESISTOR ±1% RN60C
- ALL OTHER RESISTORS 1/4 WATT ±5% CARBON
- ALL I.C.'S 1558
- TRIM POSTS
- TEST POINT

Figure 15B (0152C9087 Sh.4) Internal Connections for 50 Hertz Operate Signal Card (OS)

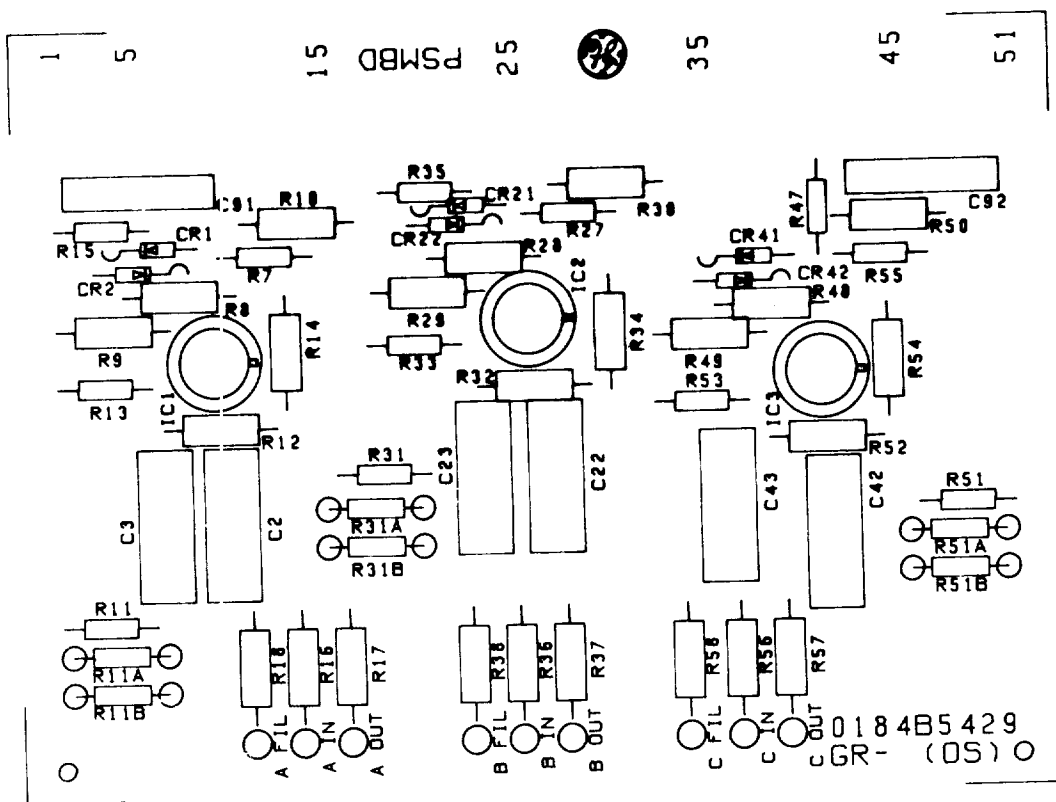
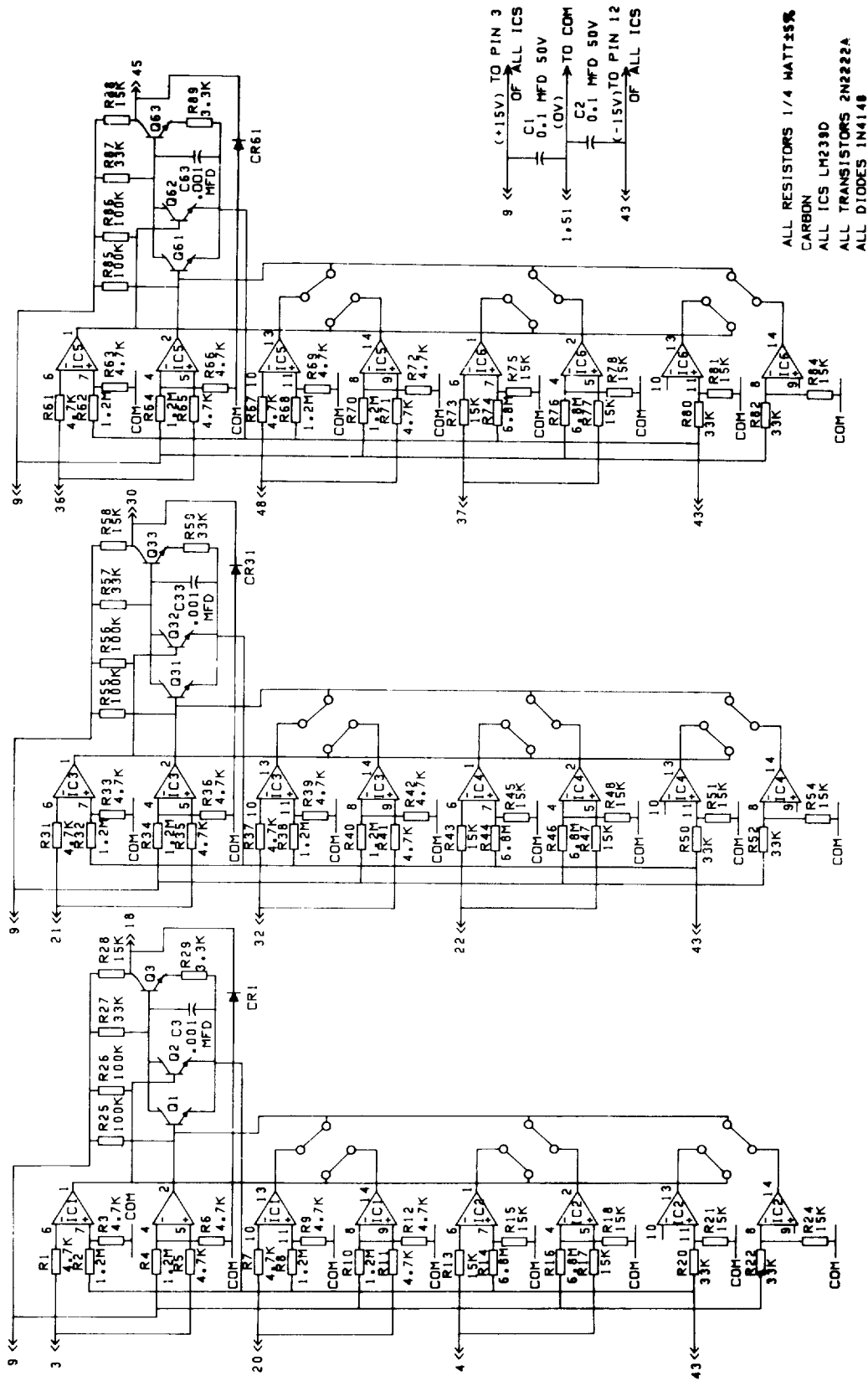

Figure 15C (0152C8440-3) Card Layout for Operate Signal Card

PCB 0152C8436 P-1  
 ASM 018485425 G-3

PHASE A CIRCUIT      PHASE B CIRCUIT      PHASE C CIRCUIT



ALL RESISTORS 1/4 WATT 5%  
 CARBON  
 ALL ICS LM2390  
 ALL TRANSISTORS 2N2222A  
 ALL DIODES 1N4148

Figure 16A (0152C9083 Sh.3) Internal Connections for Coincidence Logic Card (CL)

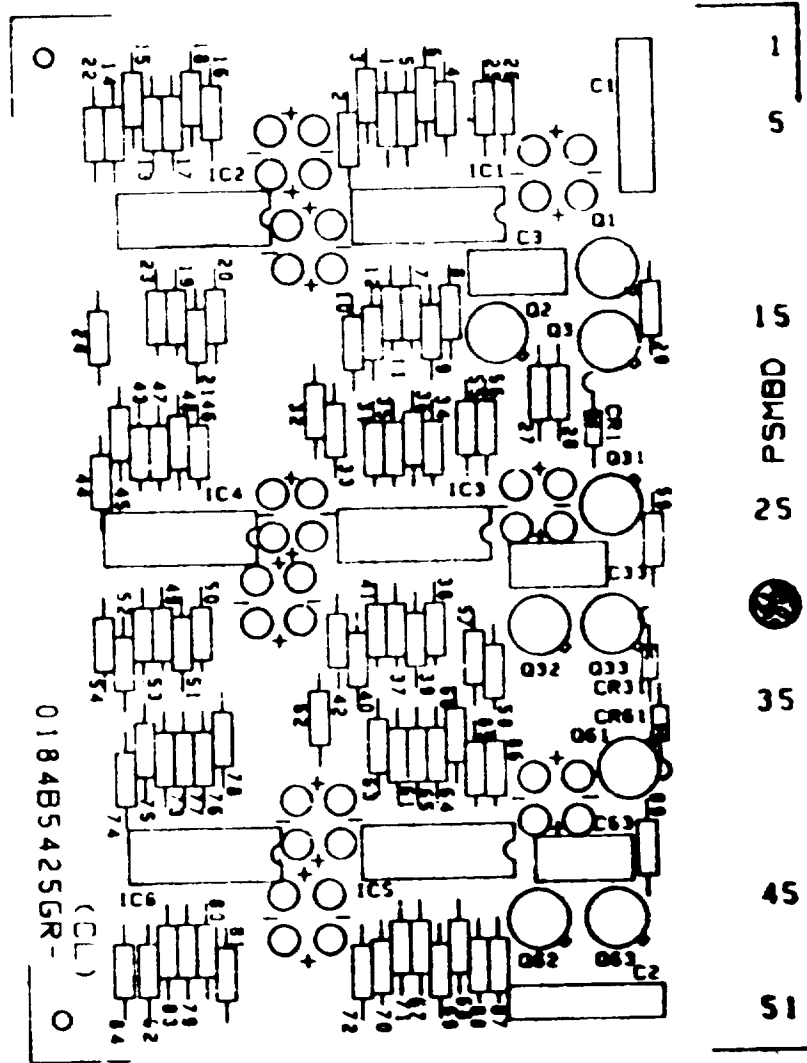

Figure 16B (0152C8436 [4]) Card Layout for Coincidence Logic Card (CL)

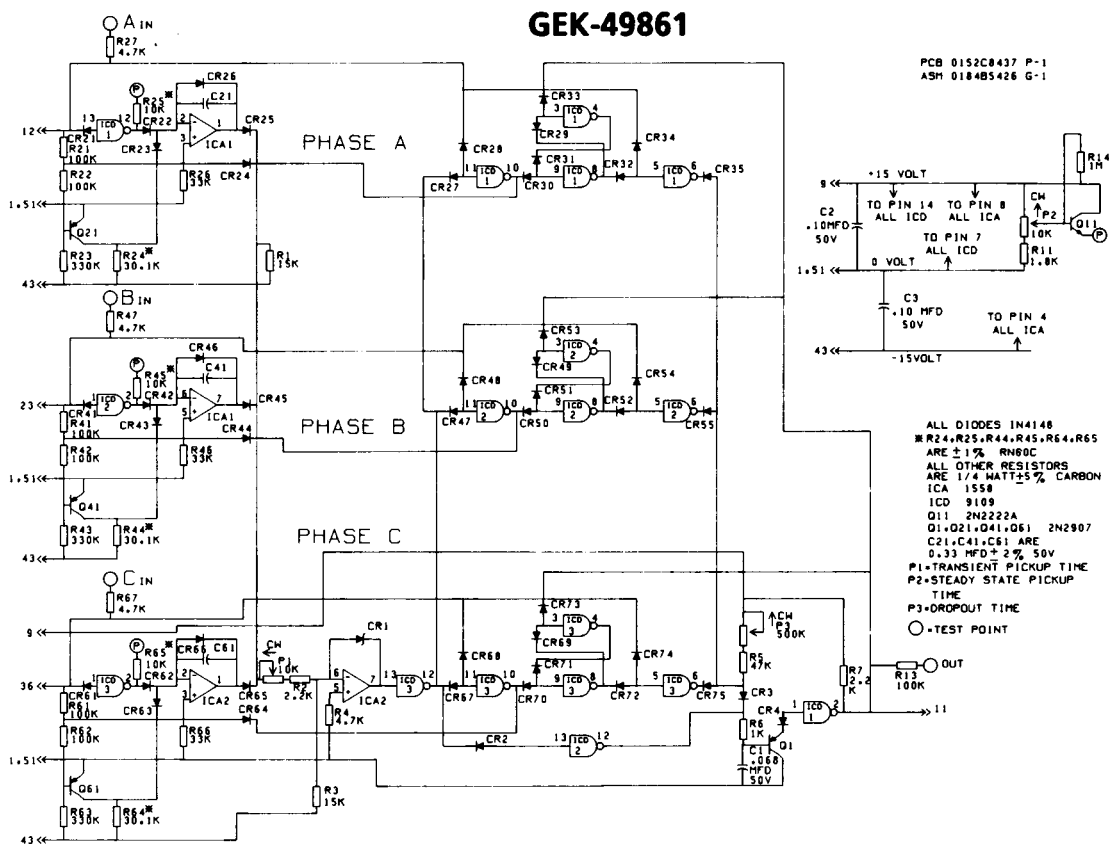

Figure 17A (0152C9084 Sh.1 [2]) Internal Connections for Integrating Timer Card (IT)

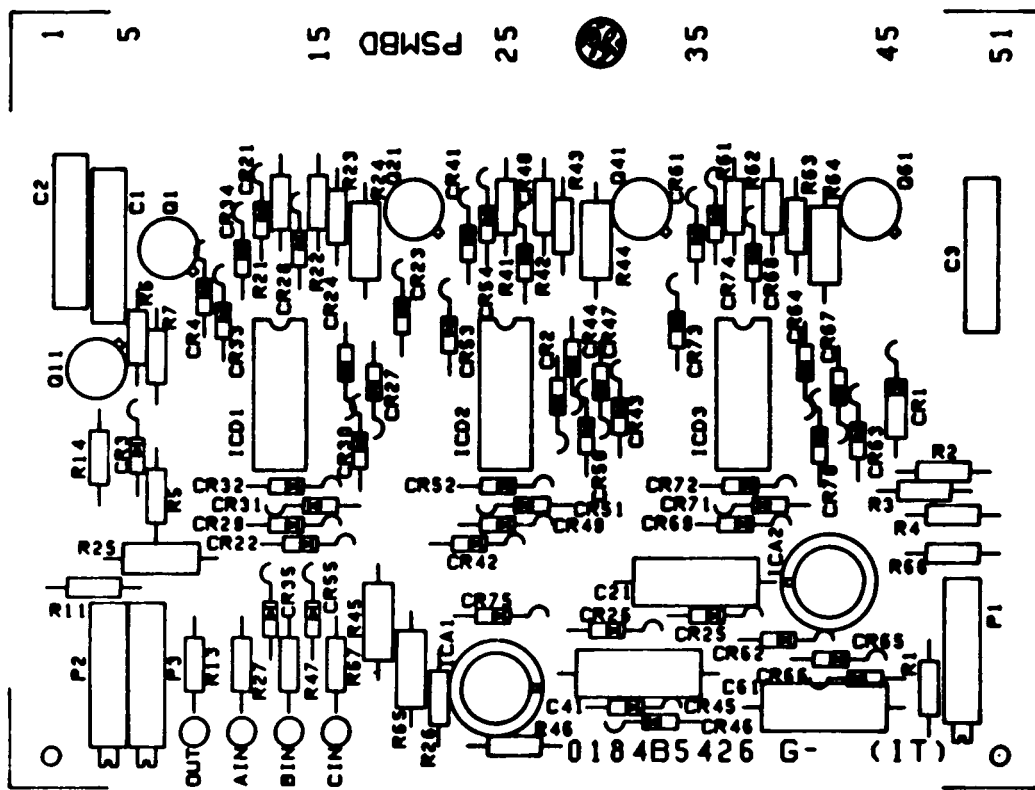

Figure 17B (0152C8437 [7]) Card Layout for Integrating Timer Card (IT)

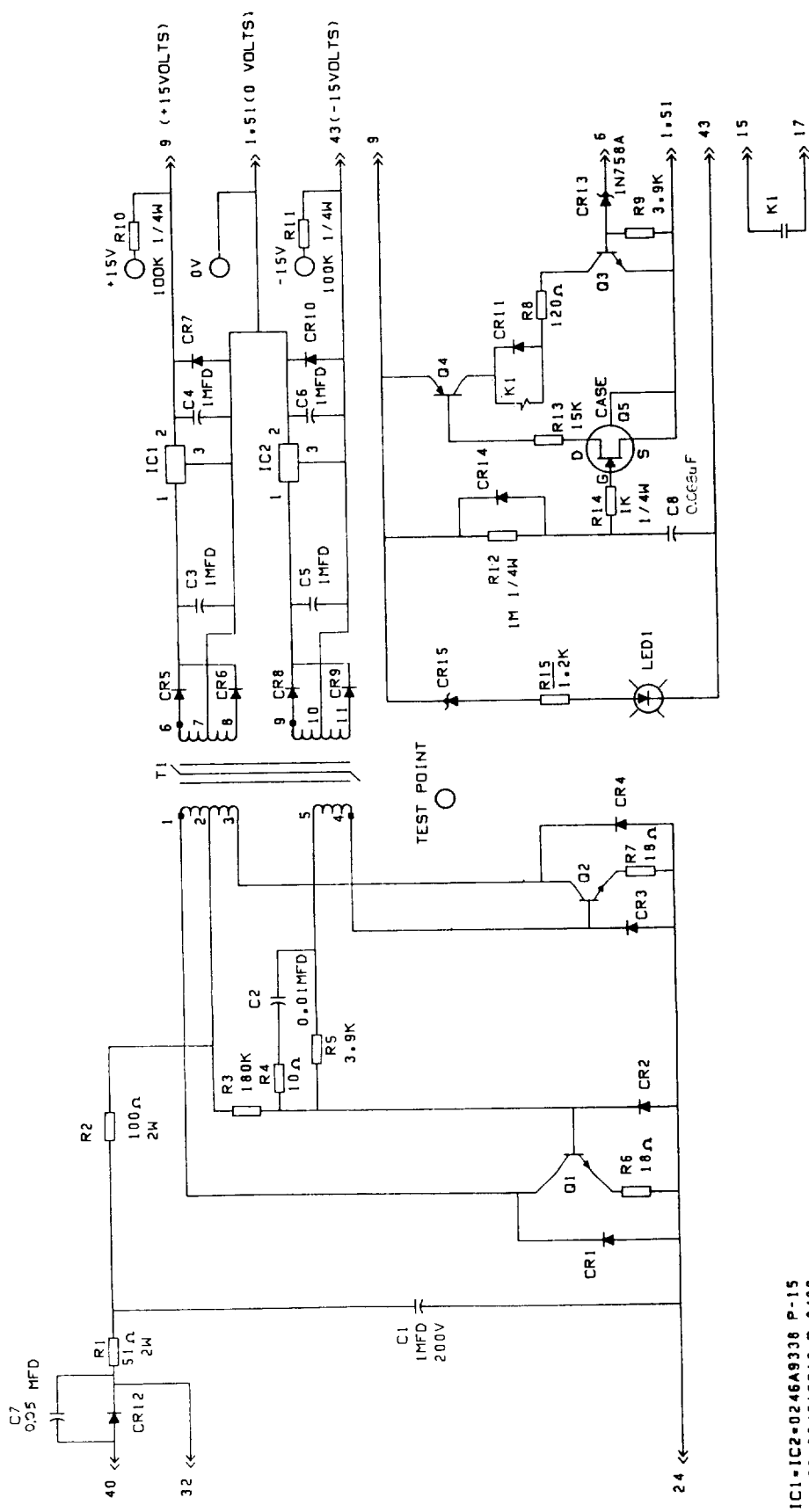
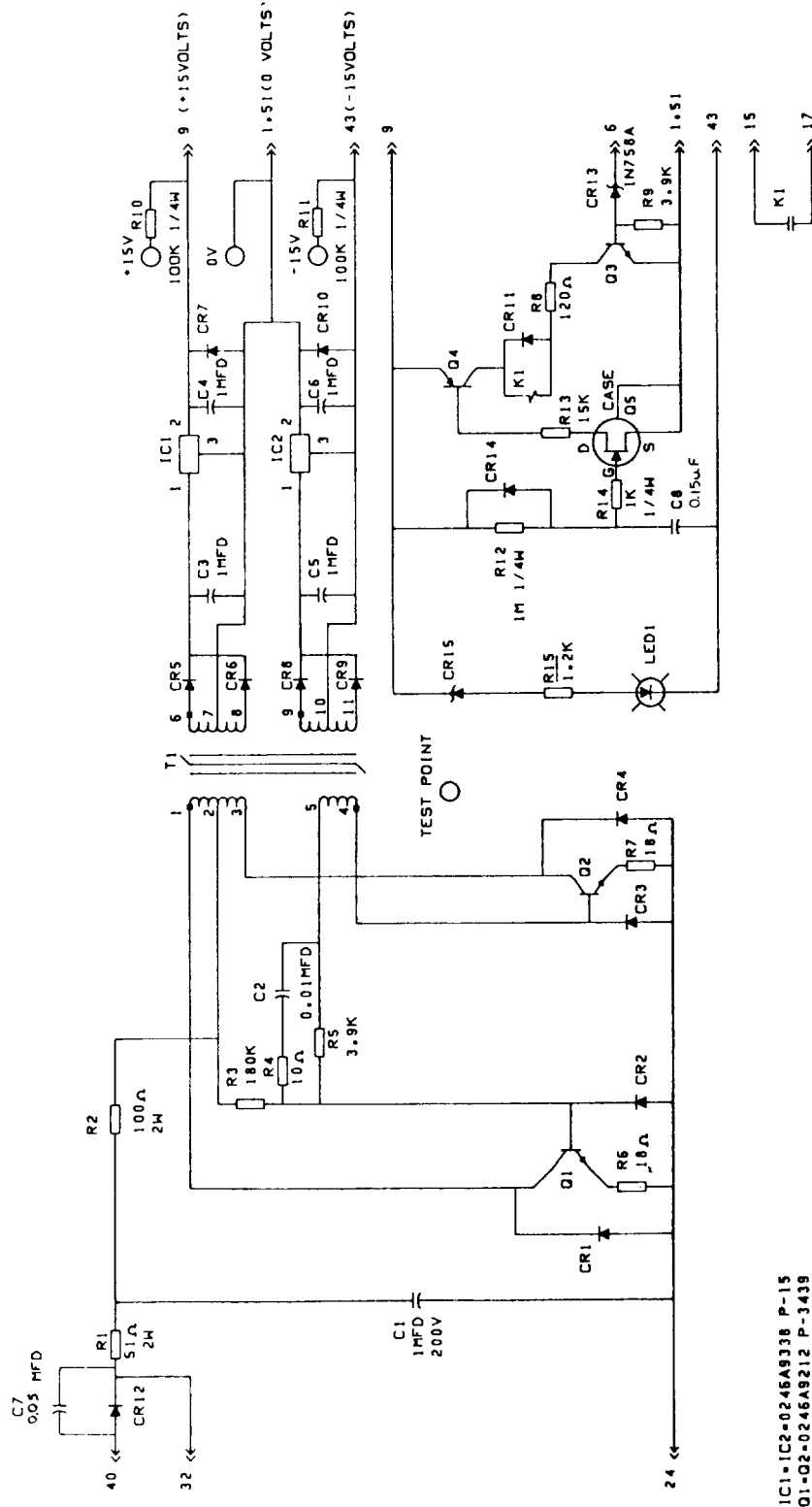

Figure 18A (0152C8465 Sh.1 [4]) Internal Connections for 125 Volt DC Rated Input power Supply Card (PS)

PCB 0171C8709  
 ASM 0184BS609 G-1



- IC1-IC2=0246A9338 P-15
- Q1-Q2=0246A9212 P-3439
- Q3=0246A9201 P-2222
- Q4=0246A9202 P-2907
- Q5=0246A9220 P-4221

Figure 18B (0152C8465 Sh.3 [2]) Internal Connections for 110 Volt DC Rated Input Power Supply Card (PS)



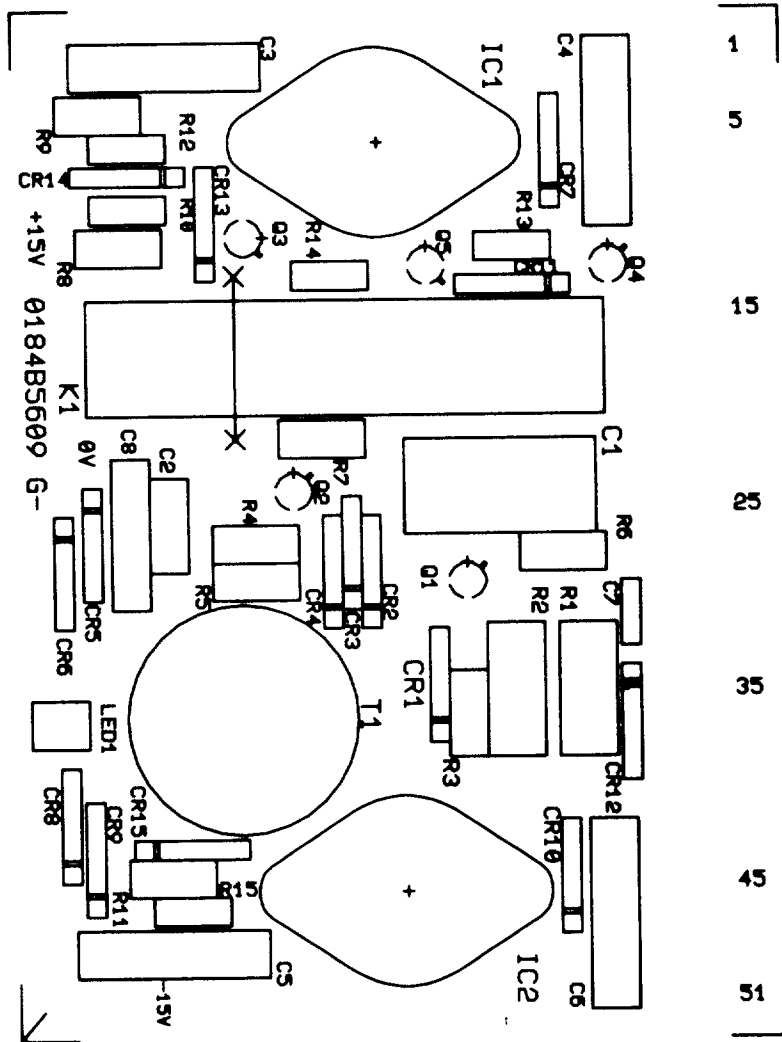
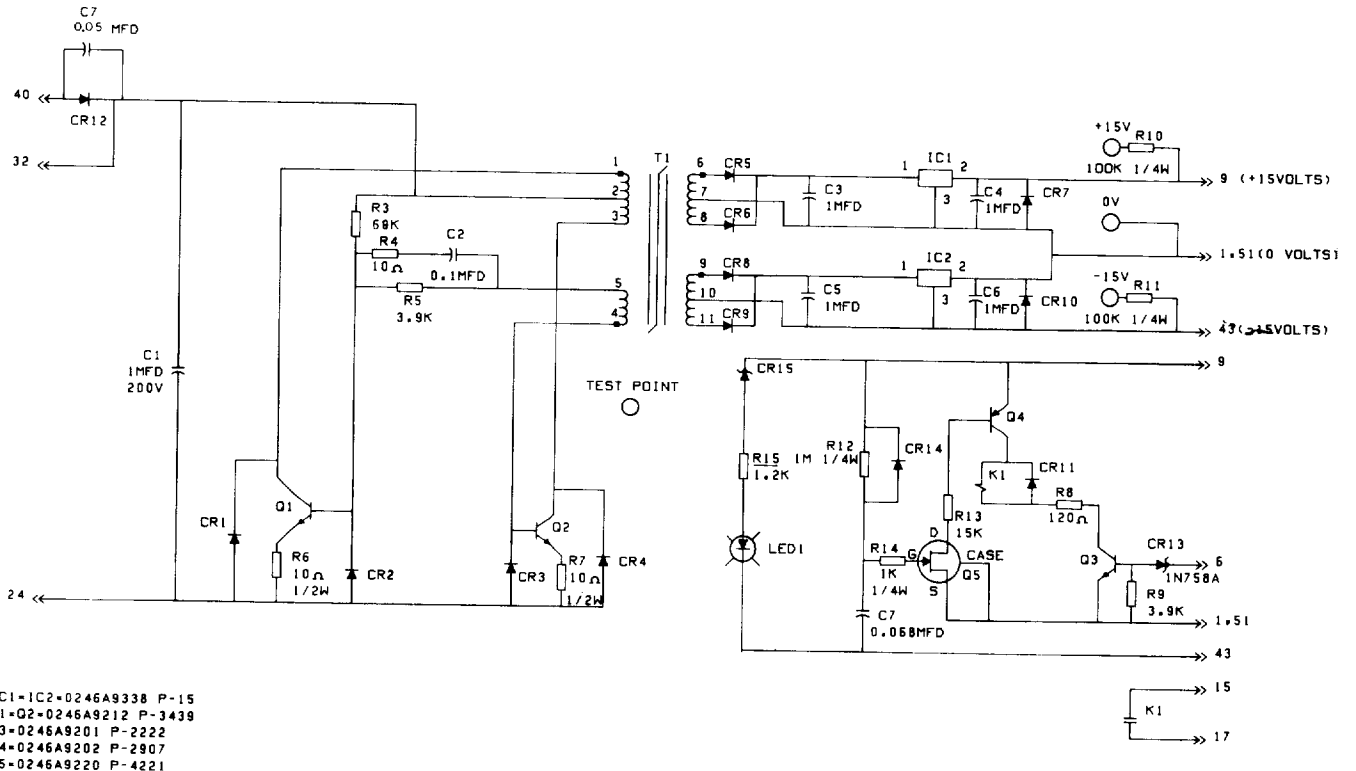
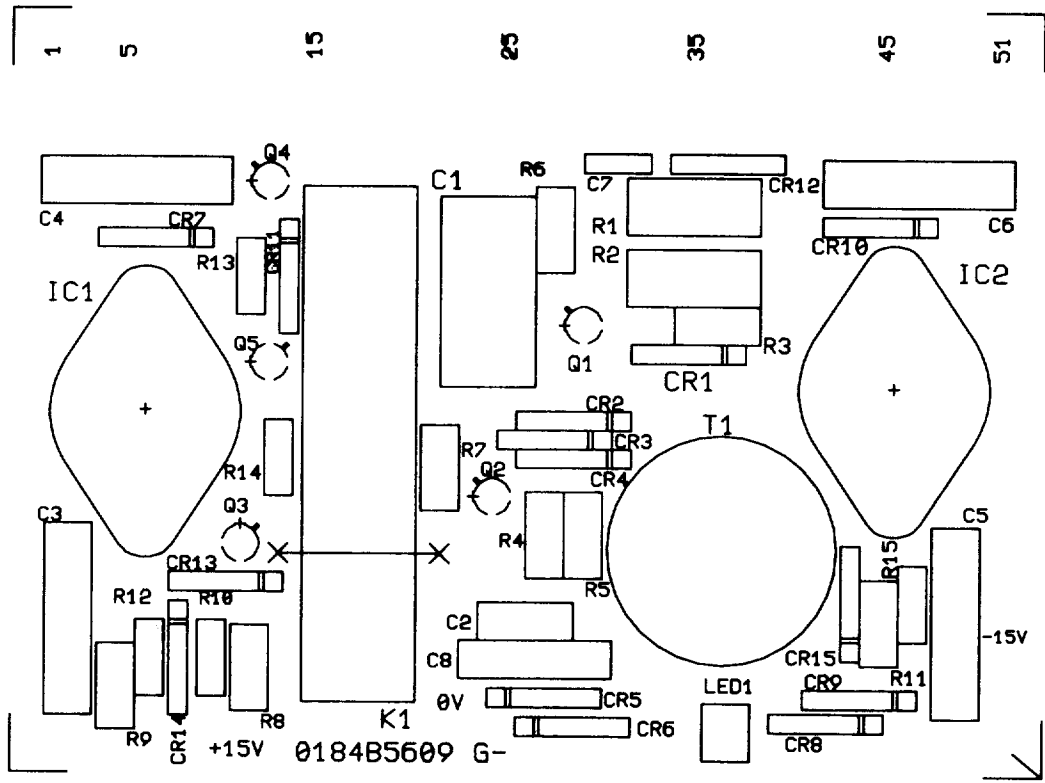

Figure 18C (0171C8709 SS Sh.1 [8]) Card Layout for 110-125 Volt Rated Input Power Supply Cards (PS)



IC1-IC2=0246A9338 P-15  
 Q1-Q2=0246A9212 P-3439  
 Q3=0246A9201 P-2222  
 Q4=0246A9202 P-2907  
 Q5=0246A9220 P-4221

**Figure 19A (0152C8465-2 Sh.2) Internal Connections for 48 Volt DC Rated Input Power Supply Card (PS)**  
 Fig. 19A (0152C8465-2 SH-2) Internal Connections for 48 Volt DC Rated Input Power Supply Card (PS)



**Figure 19B (0171C8709 SS Sh.1 [8]) Card Layout for 48 Volt DC Rated Input Power Supply Card (PS)**

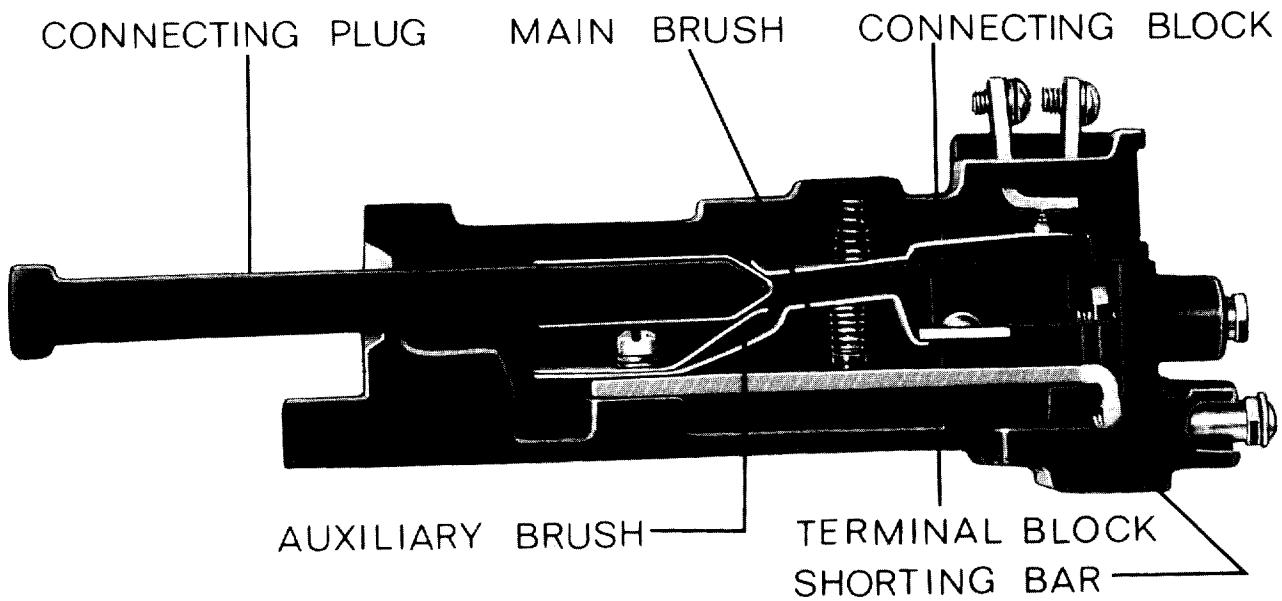

NOTE: AFTER ENGAGING AUXILIARY BRUSH CONNECTING PLUG TRAVELS  $\frac{1}{4}$  INCH BEFORE ENGAGING THE MAIN BRUSH ON THE TERMINAL BLOCK

Figure 20 (8025039) Cradle Block and Terminal Block Cross Section

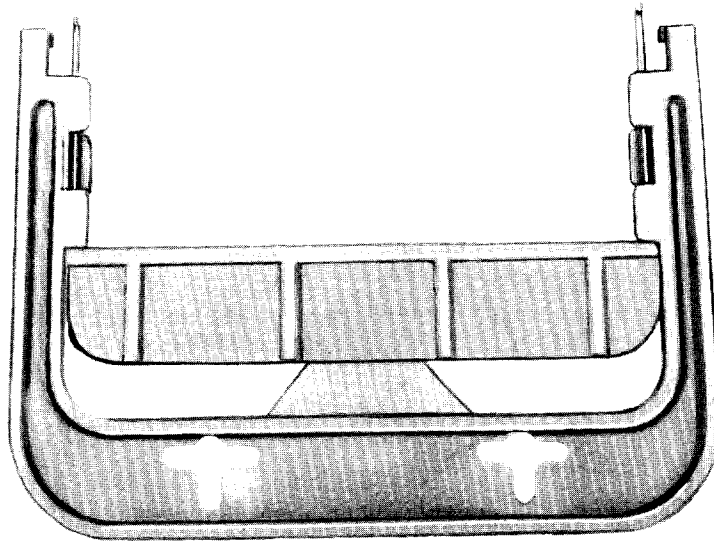

Figure 21 (8043016) Printed Circuit Card Extracting Tool

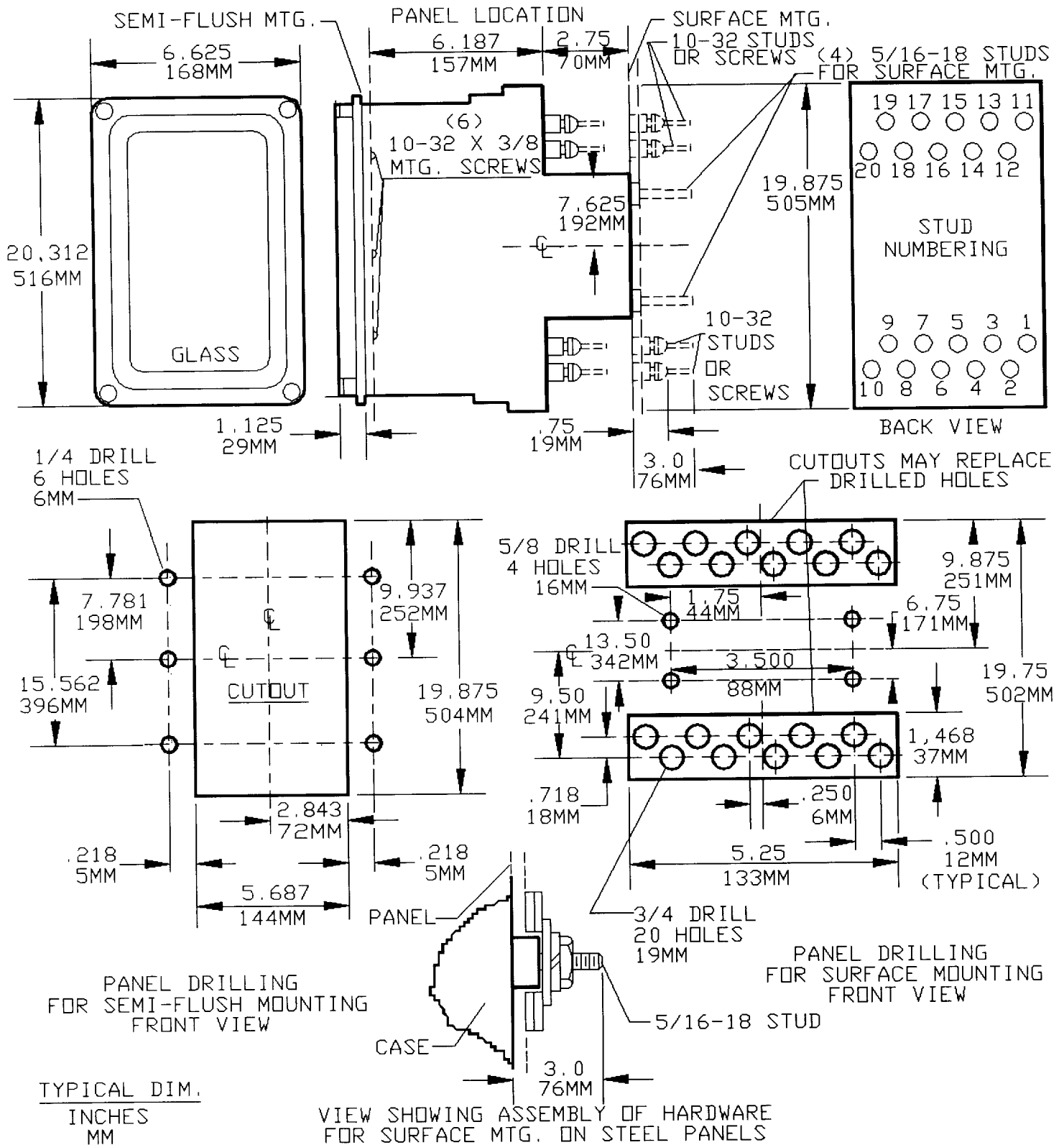

Figure 22 (0178A7336 [6]) Outline and Panel Drilling for Type SLY81A Relay

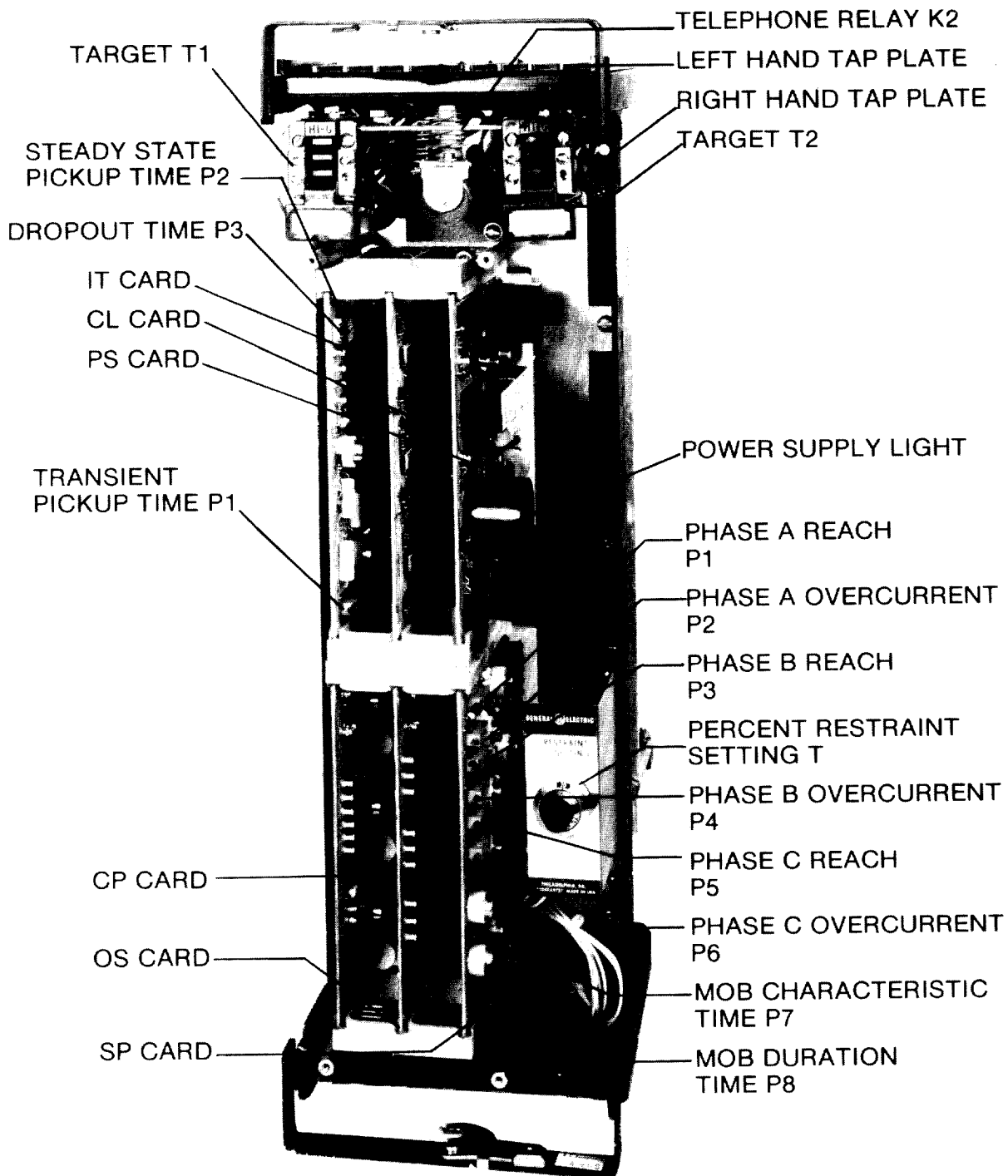

Figure 23 (8043541) Front View of relay Out of Case with Nameplate Removed

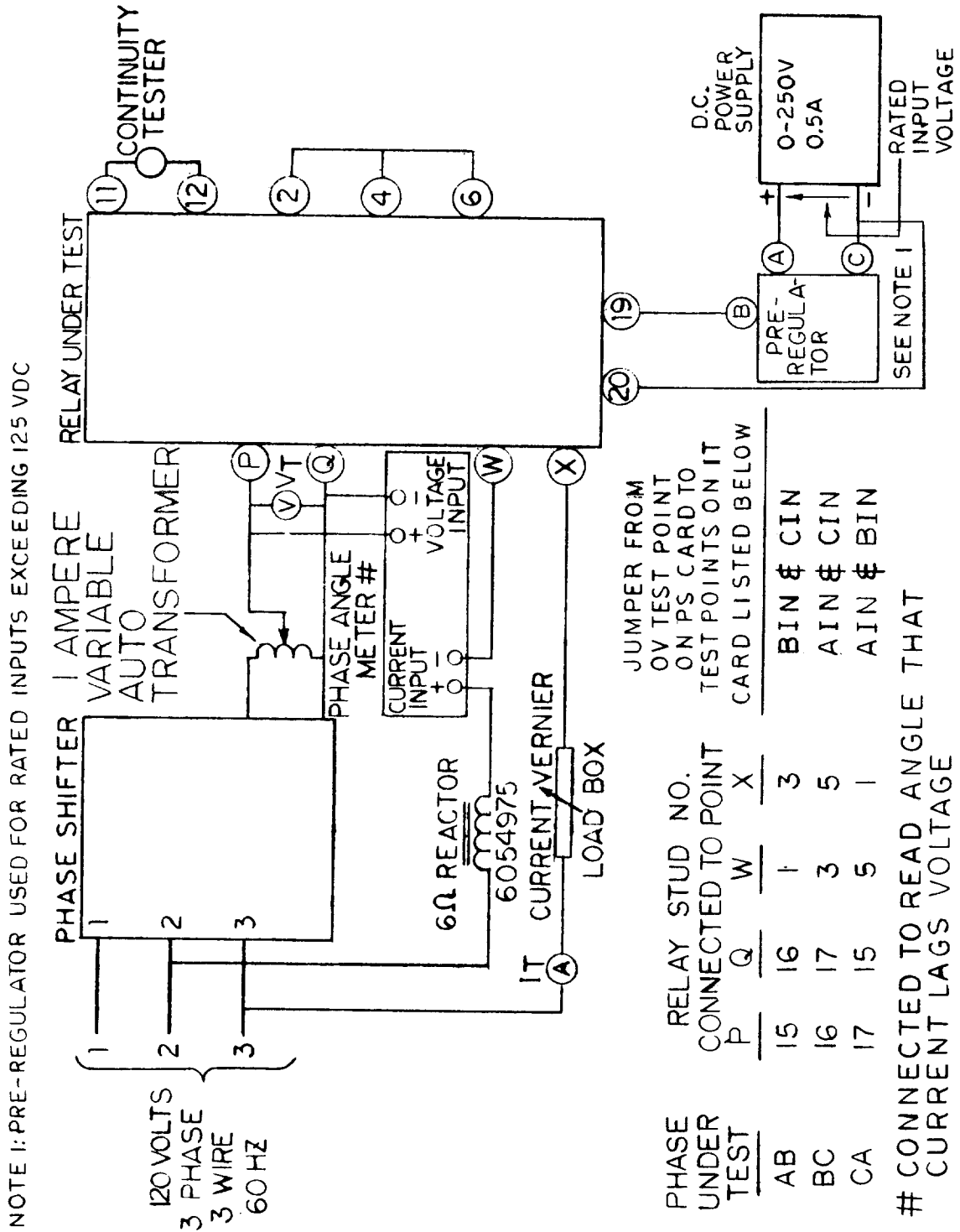

Figure 24 (0273A9097-1) Test Circuit for Reach Tests

NOTE 1: PRE-REGULATOR USED FOR RATED INPUTED INPUTS EXCEEDING 125VDC

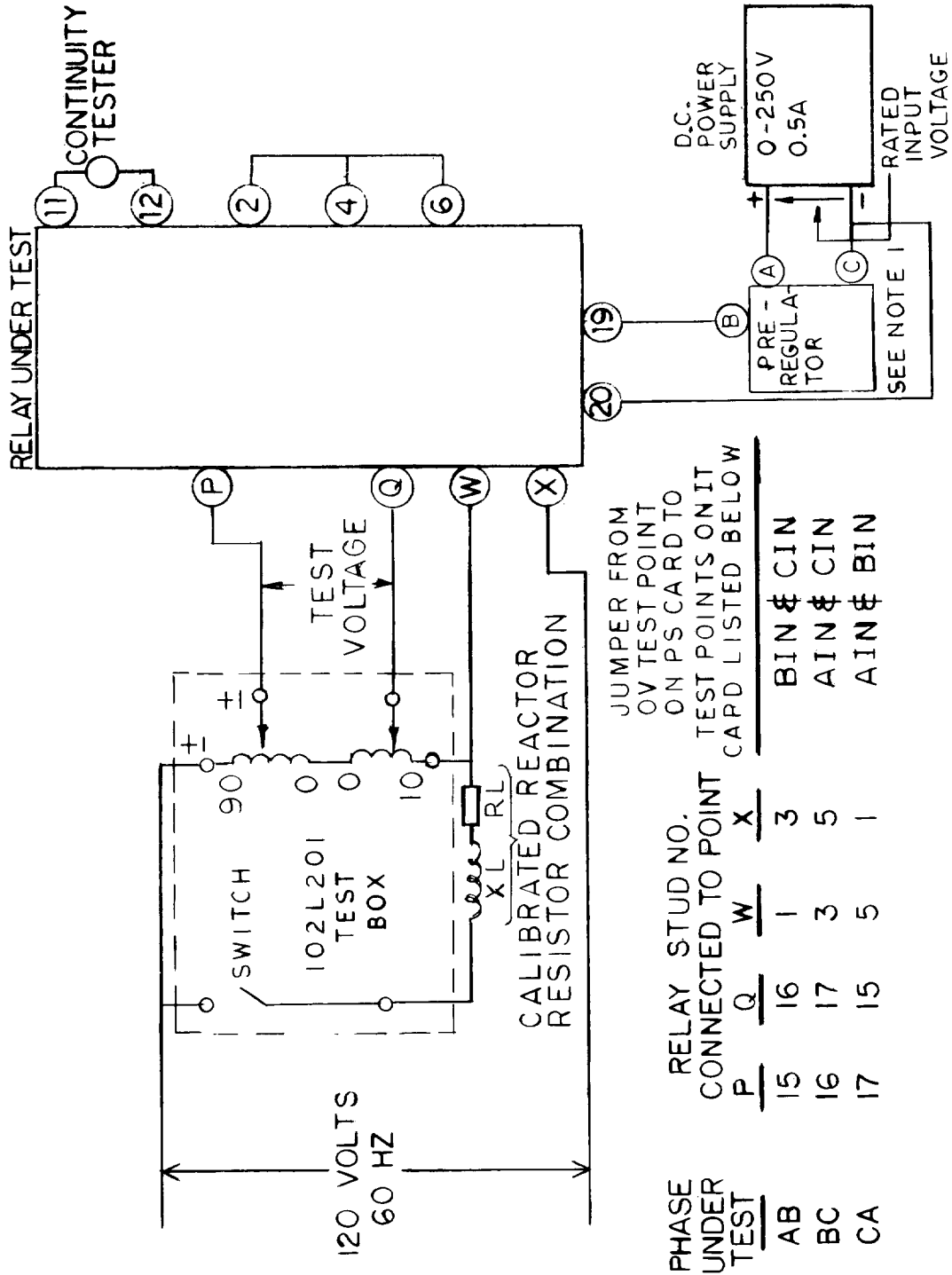
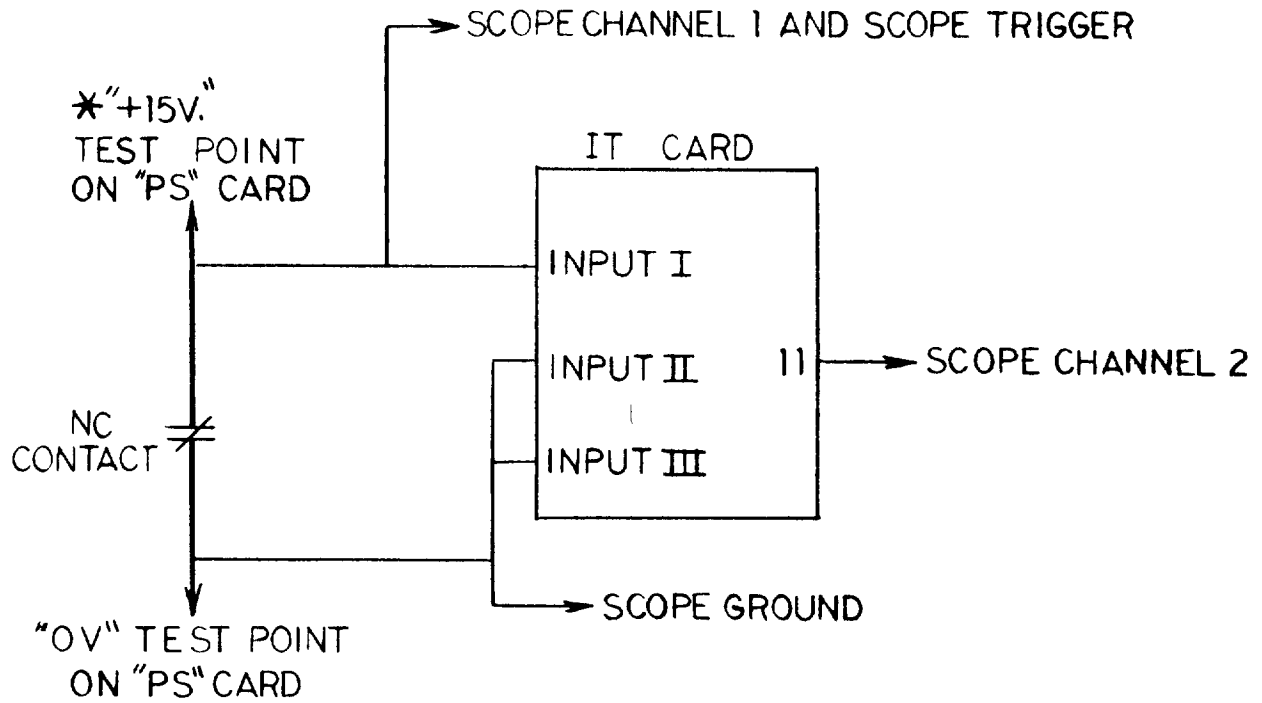

Figure 25 (0273A9098-1) Characteristic Test Circuit Using Test Box, Reactor and Resistor

\* THE "+15V." TEST POINT HAS A 100K OHM CURRENT LIMITING RESISTOR MOUNTED ON THE "PS" CARD.



PHASE UNDER TEST	PIN No. OF CARD		
	<u>INPUT I</u>	<u>INPUT II</u>	<u>INPUT III</u>
AB	12	23	36
BC	23	12	36
CA	36	12	23

Figure 26 (0273A9099) Timer Card Test Circuit



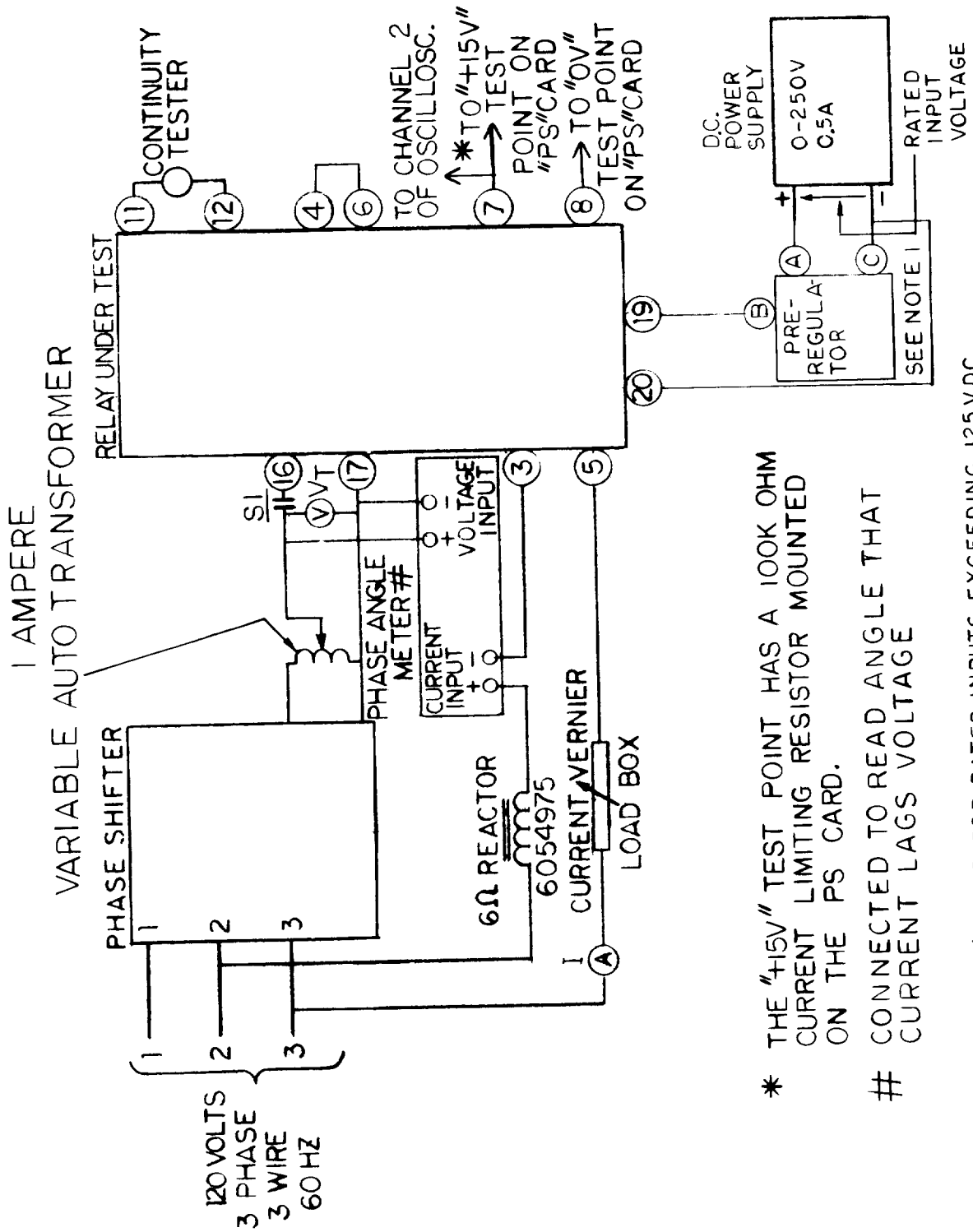

Figure 27 (0273A9100-2) Test Circuit for MOB Test

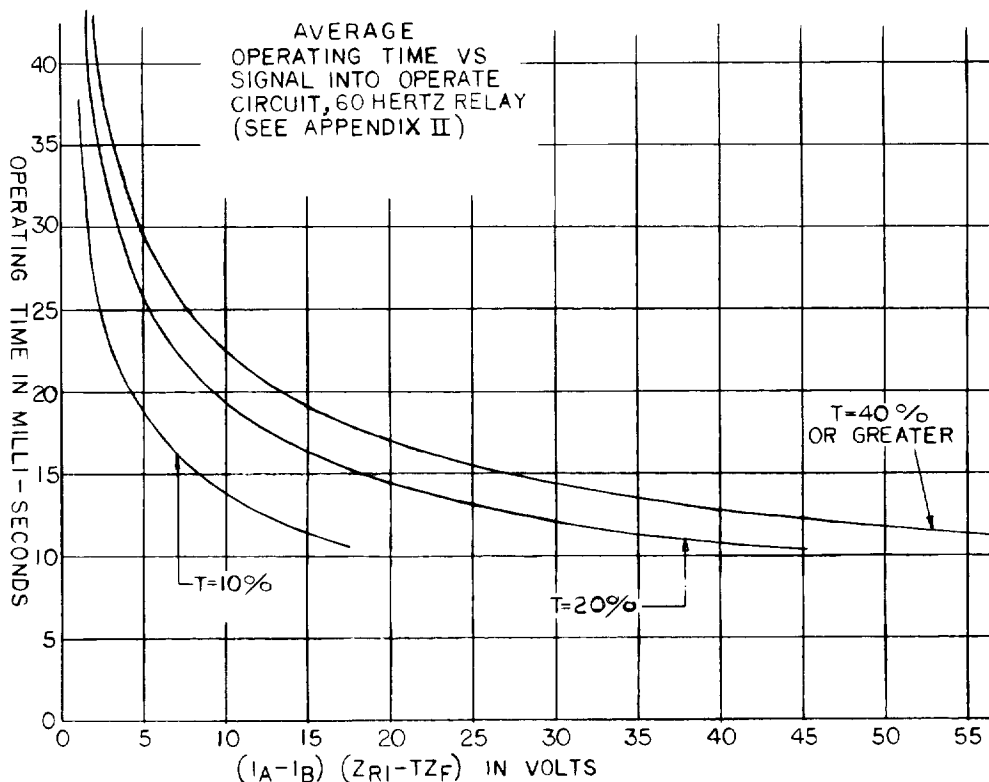

Figure 28A (0273A9101-4 Sh.1) Operating Time of 60 Hertz Relay Versus Signal into Operating Circuit

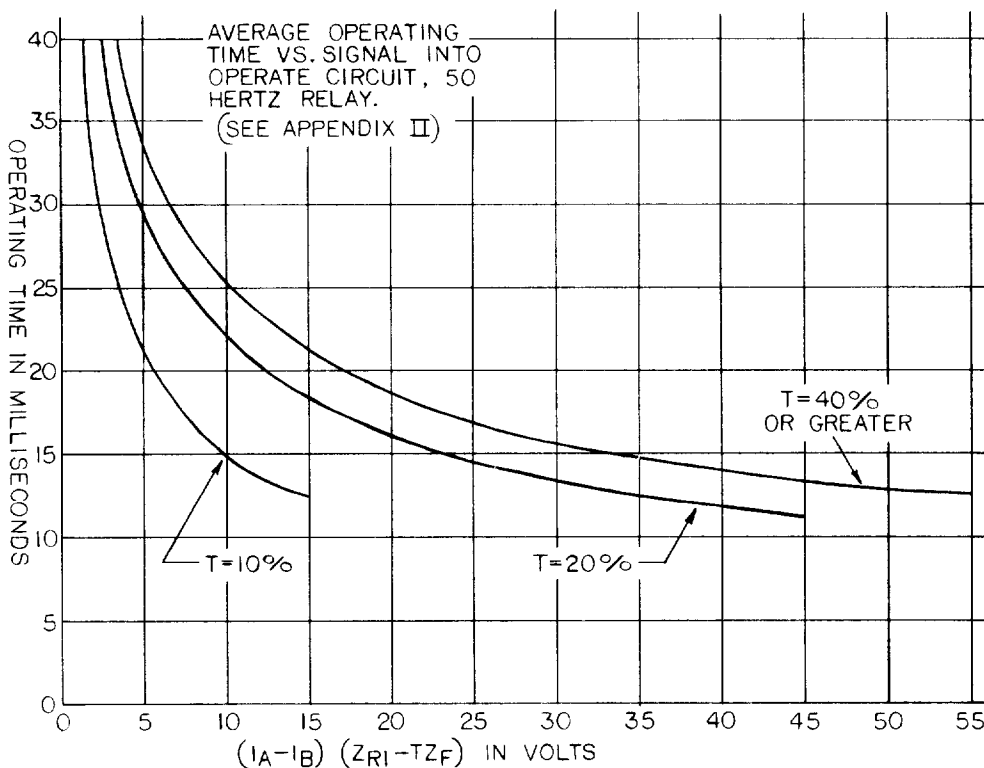
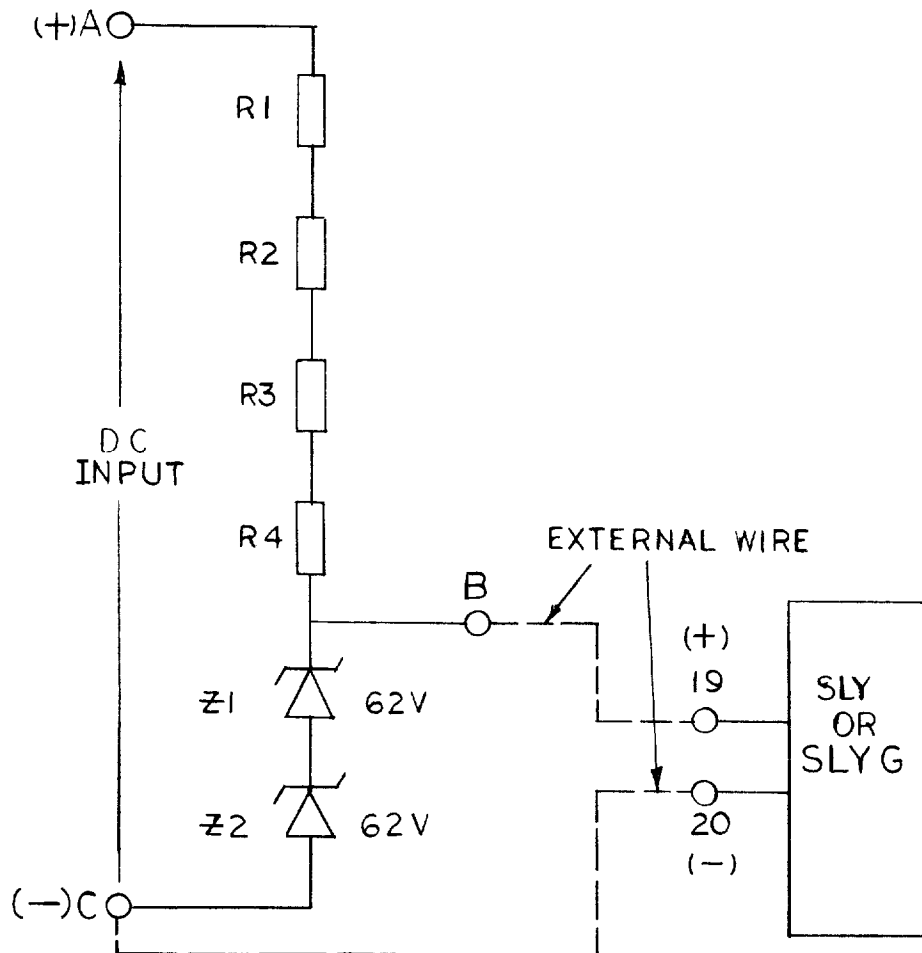

Figure 28B (0273A9101 Sh.2) Operating Time of 50 Hertz Relay Versus Signal into Operating Circuit



DC INPUT	R1	R2	R3	R4
250 VOLTS	150 $\Omega$	150 $\Omega$	100 $\Omega$	100 $\Omega$

Figure 29 (0275A4336-1) Internal Connections Diagram of Pre-Regulator

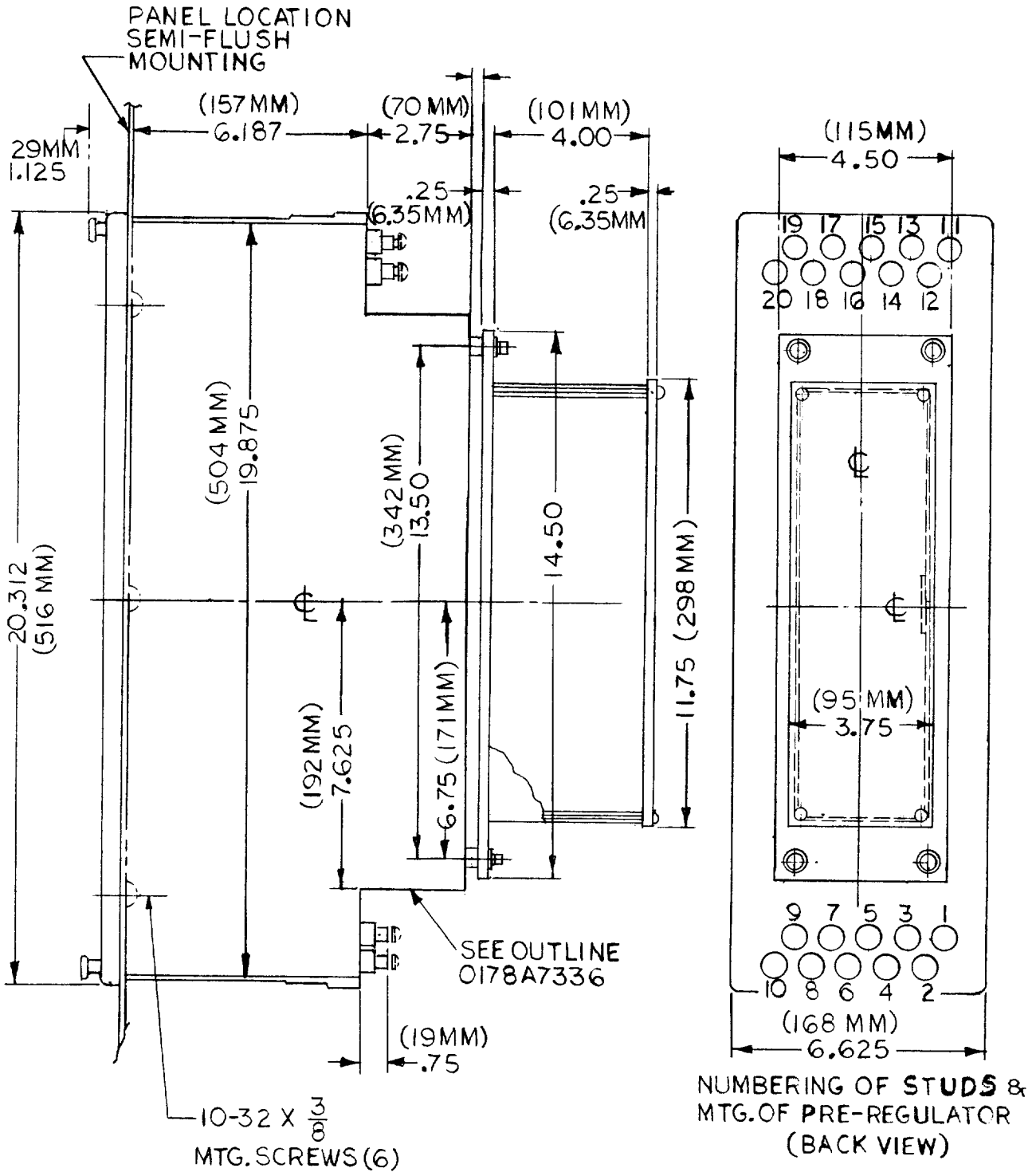

Figure 30 (0275A4339) Outline and Mounting Dimensions with Pre-Regulator

NOTE 1: PRE-REGULATOR USED FOR RATED INPUTS EXCEEDING 125 VDC

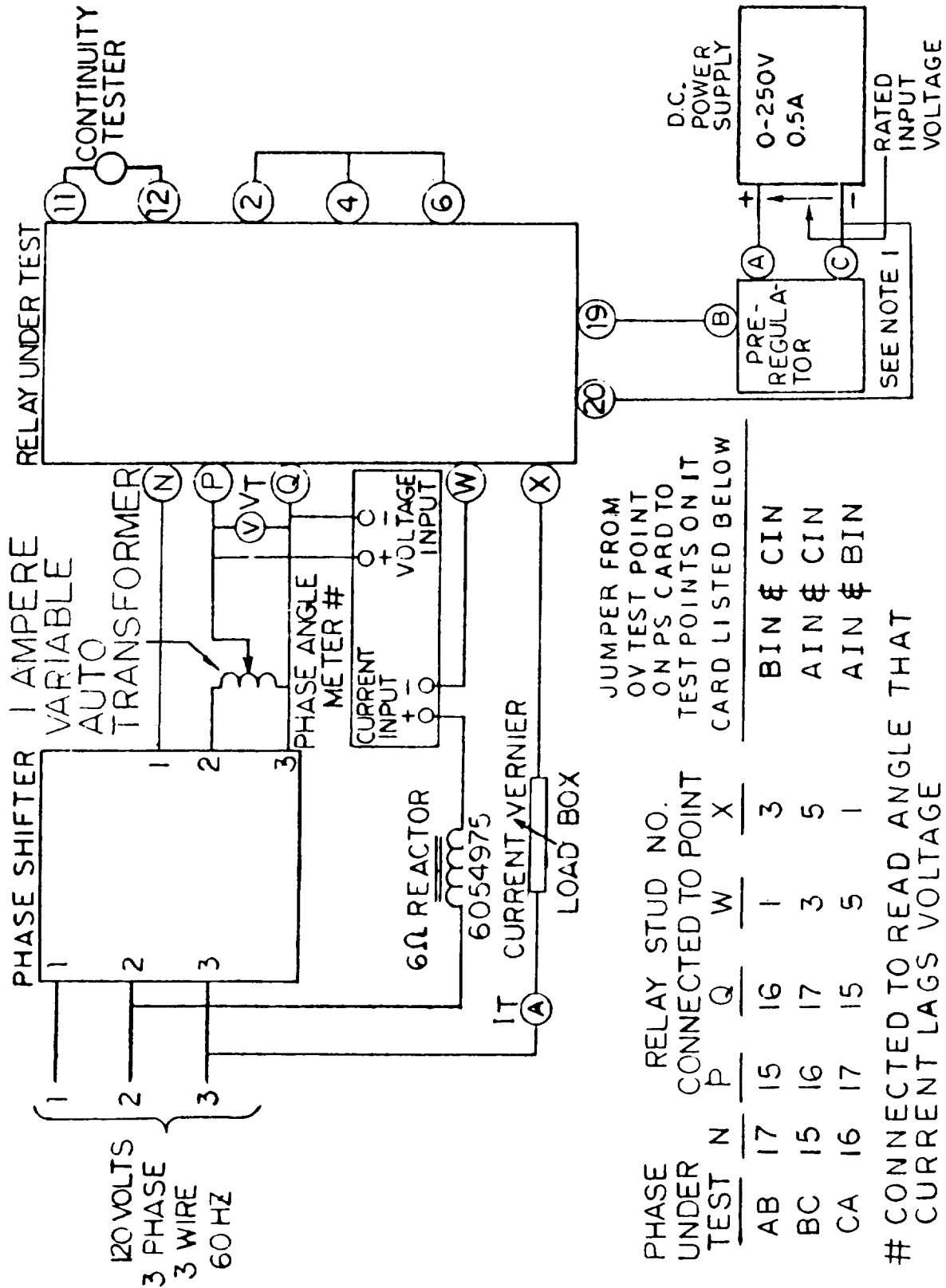

Figure 31 (0285A9951) Test Circuit for Characteristic Tests



---

***GE Power Management***

**215 Anderson Avenue  
Markham, Ontario  
Canada L6E 1B3  
Tel: (905) 294-6222  
Fax: (905) 201-2098  
[www.ge.com/indsys/pm](http://www.ge.com/indsys/pm)**