



**INSTRUCTIONS**

GEK-49870 B  
Supersedes GEK-49870 A

---

**STATIC GROUND MHO DISTANCE RELAY**

**TYPE SLYG61A**

---

**GENERAL  ELECTRIC**

CONTENTS

	<u>PAGE</u>
DESCRIPTION .....	3
APPLICATION .....	3
RATINGS .....	4
RANGES .....	4
BURDENS .....	4
SENSITIVITY .....	5
OPERATING CIRCUIT SENSITIVITY .....	5
NUMBER ONE POLARIZING CIRCUIT SENSITIVITY ( $V_{AG} + KV_{AG1}$ ) .....	5
NUMBER TWO POLARIZING CIRCUIT SENSITIVITY ( $TOKO I_0 BOT_0 - V_0$ ) .....	6
OPERATING PRINCIPLES AND CHARACTERISTICS .....	6
GENERAL .....	6
RELAY REACH .....	6
ANGLE OF MAXIMUM REACH .....	7
PHASE ANGLE MEASUREMENT .....	7
ZERO SEQUENCE CURRENT COMPENSATION .....	7
CALCULATION AND CHOICE OF SETTINGS .....	7
CONSTRUCTION .....	9
RECEIVING, HANDLING AND STORAGE .....	9
INSTALLATION TESTS .....	10
CAUTION .....	10
GENERAL .....	10
NECESSARY ADJUSTMENTS .....	10
DETAILED TESTING INSTRUCTIONS .....	11
$T_0 I_0 Z_0$ MAGNITUDE AND ANGLE .....	11
BASE REACH SETTING .....	11
VOLTAGE RESTRAINT TAP SETTING .....	11
ANGLE OF MAXIMUM REACH SETTING .....	11
ZERO SEQUENCE CURRENT COMPENSATION SETTING .....	12
CHARACTERISTIC TIMER SETTING .....	12
OVERALL CHECK OF THE MTG FUNCTION .....	13
BASE REACH ANGLE AND REACH CHECK .....	13
COMPLETE MTG FUNCTION CHECK .....	15
PERIODIC CHECKS AND ROUTINE MAINTENANCE .....	16
PERIODIC CHECKS .....	16
TROUBLESHOOTING .....	16
SPARE PARTS .....	16
TERMS .....	16

STATIC GROUND MHO DISTANCE RELAY  
TYPE SLYG61A

DESCRIPTION

The SLYG61A is a first zone, three phase, static ground distance relay. It is a rack mounting unit, two rack units high and requires other fault detecting relays, an SSA power supply, SLA logic unit(s), SLAT output unit(s), and a test panel to provide a complete scheme.

APPLICATION

The SLYG61A relay utilizes three input phase angle comparators for the ground distance measurement. The three inputs for the phase A-to-ground measurement are:

- |     |   |                    |
|-----|---|--------------------|
| (a) | $(I_A - I_0)Z_{R1} + I_0 K_0 Z_{R0} - T V_{AN}$ | Operating Quantity |
| (b) | $V_{BC} \angle 90^\circ$                        | #1 Polarizing      |
| (c) | $T_0 K_0 I_0 Z_{R0} - V_0$                      | #2 Polarizing      |

where:

- |                          |  |
|--------------------------|--|
| $I_A$                    | is the faulted phase current   |
| $I_0$                    | is the zero sequence component of current  |
| $Z_{R1}$                 | is the phase (positive and negative) base reach impedance with a selectable impedance angle of 85 degrees or 75 degrees  |
| $Z_{R0}$                 | is the zero sequence base reach impedance with a selectable impedance angle of 75 degrees or 65 degrees  |
| $T_{VAN}$                | is the faulted phase line-to-neutral voltage multiplied by the restraint tap T   |
| $V_{BC} \angle 90^\circ$ | is the phase-to-phase voltage in quadrature to the faulted phase voltage, shifted 90 degrees leading so as to be in phase with the faulted phase pre-fault voltage |
| $V_0$                    | is the zero sequence voltage at the relay location   |
| $T_0$                    | is a design variable that may be set equal to 0.0, 0.1, 0.2, 0.3 or 0.4  |

*These instructions do not purport to cover all details or variations in equipment nor to provide for every possible contingency to be met in connection with installation, operation or maintenance. Should further information be desired or should particular problems arise which are not covered sufficiently for the purchaser's purposes, the matter should be referred to the General Electric Company.*

*To the extent required the products described herein meet applicable ANSI, IEEE and NEMA standards; but not such assurance is given with respect to local codes and ordinances because they vary greatly.*

$K_0$  is a ratio tap to compensate for the magnitude ratio between the zero and positive sequence line impedance

The use of a three input comparator provides advantages over previous designs in simplifying the application of a ground distance relay. The #1 and #2 polarizing signals will be approximately in phase in the faulted phase comparator and approximately 120 degrees or more out of phase in the unfaulted phases. Hence the traditional concern of the unfaulted phases operating for a fault behind the relay is not a problem with the SLYG61A.

The use of the quadrature voltage for the #1 polarizing signal produces a "variable mho" characteristic, that is, a characteristic which increases in size as the source impedance increases to accommodate increasing arc resistance.

The SLYG61A has an adjustable characteristic which is adjusted by means of the timer setting on the characteristic timer. For short lines a circular characteristic is recommended, but, for longer lines, lines with unusually heavy load transfer, or three terminal lines where very large reach settings are applied, a lens shaped characteristic is recommended.

RATINGS

This relay is designed for use in an environment where the air temperature outside the relay case is between -20°C and +65°C.

Forms of the SLYG61A are available for either 50 or 60 hertz applications.

Forms of this relay are available with current circuits rated for either five amperes or one ampere for continuous duty and have a one second rating of 300 or 60 amperes respectively.

The potential circuits are rated for 69 volts.

The relay requires a  $\pm 15$  VDC power source which may be obtained from type SSA power supplies.

Refer to the unit nameplate for the frequency and current ratings for a particular relay.

RANGES

The SLYG61A relay has an adjustable reach of 0.1 to 30 ohms for the five ampere rated relay or 0.5 to 150 ohms for the one ampere rated relay.

Current input connections to establish the basic ohmic tap of one and three ohms line-to-neutral (five ampere relay) or five and fifteen ohms (one ampere relay) are available at the current input terminals. Restraint taps in the voltage circuit range between 10 and 100 percent in one percent increments. In addition to the current input taps the relay has a selectable base reach multiplier of 1.0, 0.5, 0.2 or 0.1 per unit.

The relay has a positive sequence base reach angle which can be adjusted for 85 or 75 degrees.

The relay has a zero sequence current compensation circuit with a  $K_0$  ( $Z_0/Z_1$ ) adjustment range of 1.0 to 10.9 per unit in 0.1 per unit steps. The zero sequence base reach angle can be adjusted for 75 or 65 degrees.

The polarizing voltage has an adjustable phase shift relative to the operating quantity of zero or fifteen degrees lead.

BURDENS

The maximum potential burden per phase, measured at 60 volts rms is:

60 Hz Relay	50 Hz Relay	
0.35	0.45	Volt-ampere Watt Var
0.28	0.34	
0.20	0.29	

The maximum phase current burden per phase is:

5 Ampere Relay	
1 or 3 $\Omega$ Tap	
Z: 0.024 $\angle 7.0^\circ$	0hm
R: 0.024	0hm
Z: 0.003	0hm

1 Ampere Relay	
1 or 15 $\Omega$ Tap	
Z: 0.115 $\angle 1.5^\circ$	0hm
R: 0.115	0hm
X: 0.003	0hm

The maximum zero sequence current burden is:

5 Ampere Relay	
1 or 3 $\Omega$ Tap	
Z: 0.024 $\angle 7.0^\circ$	0hm
R: 0.024	0hm
X: 0.003	0hm

1 Ampere Relay	
1 or 15 $\Omega$ Tap	
Z: 0.115 $\angle 1.5^\circ$	0hm
R: 0.115	0hm
X: 0.003	0hm

The maximum burdens that the logic circuits present to the power supply are:

0.240	Ampere to the +15 VDC supply
0.120	Ampere to the -15 VDC supply

SENSITIVITY

Sensitivity is defined as the steady state rms voltage or current, measured at the relay terminals, required for a particular quantity to cause the relay to operate if all input quantities are in the optimal phase relationship. The nominal sensitivities for the signal quantities in the SLYG61A relay are as follows:

OPERATING CIRCUIT SENSITIVITY

To determine the current sensitivity the ratio of  $I_0$  to  $I_\phi$  (phase current) must be known or assumed. The current sensitivity can then be determined from the relationship:

$$(I_\phi - I_0) Z_{R1} + I_0 K_0 Z_{R0} = \frac{0.20}{1-X}$$

where

$$X = \frac{\text{Actual Relay Reach}}{\text{Nominal Relay Reach}}$$

For example, if  $I_\phi = 3I_0$ ,  $Z_{R1} = Z_{R0} = 3\Omega$ ,  $K_0 = 3$  and  $X = 0.9$ , then:

$$2I_\phi + 3I_\phi = 2.0$$

$$I_\phi = 0.40 \text{ ampere}$$

NUMBER ONE POLARIZING CIRCUIT SENSITIVITY ( $V_{BC} \angle 90$ )

Sensitivity is fifteen percent of rated voltage.

NUMBER TWO POLARIZING CIRCUIT SENSITIVITY ( $T_0 K_0 I_0 BOT_0 - V_0$ )

The current sensitivity can be determined from the relationship:

$$T_0 K_0 I_0 BOT_0 - V_0 = 0.05$$

OPERATING PRINCIPLES AND CHARACTERISTICS

GENERAL

The mho characteristic is obtained by converting relay currents into voltage signals (IZ), combining these IZ signals with signals proportional to the line voltage (V), and measuring the angle between the appropriate combinations to obtain the desired characteristic.

Currents are converted into IZ signals by means of transactors (TE, TG and TJ) which are air gap reactors with secondary windings. The transactors are tapped on the primary to provide the basic ohmic tap selection of one or three ohms (five ampere rating) and five or fifteen ohms (one ampere rating).

The Z of the IZ quantity is the transfer impedance of the transactor and is equal to  $V_{OUT}/I_{IN}$ . The transactor secondaries have loading resistors across them. These resistors provide the desired angle between  $V_{OUT}$  and  $I_{IN}$ . This angle determines the base reach angle of the relay.

The mho distance characteristic is obtained by comparing the phase angle between the quantities (IZ-TV) and  $V_{po1}$  where V is the phase-to-neutral voltage at the relay,  $V_{po1}$  is the polarizing voltage, I is the phase current, Z is the relay base reach and T is the voltage restraint tap. For a circular characteristic, relay operation occurs when the angle between (IZ-TV) and  $V_{po1}$  is less than or equal to 90 degrees.

RELAY REACH

The positive and negative sequence base reach of the relay ( $Z_{R1}$ ) is determined by the basic ohmic tap (BOT) and the base reach multiplier tap (BRM). The base reach is equal to the product of the basic ohmic tap and the base reach multiplier tap:

$$Z_{R1} = (BOT) (BRM) \tag{Eq 1}$$

The reach of the MTG function at the base reach angle is given by the expression:

$$Z_R = \frac{Z_{R1}}{T} \times 100 = \frac{BOT \times BRM}{T} \times 100 \tag{Eq 2}$$

To obtain the same distance measurement for all ratios of zero to positive sequence current, set:

$$K_0 = \frac{Z_{0L}}{Z_{1L}} \text{ and } Z_{R0} = Z_{R1} \tag{Eq 3}$$

where

- $Z_R$  is the positive sequence reach at the base reach angle in line-to-neutral ohms.
- T is the voltage restraint tap in percent
- $K_0$  is the zero sequence current compensation setting in per unit
- BOT is the basic ohmic tap in line-to-neutral ohms
- BRM is the base reach multiplier

$Z_{R1}$  is the positive and negative sequence base reach of the relay in line-to-neutral ohms

$Z_{R0}$  is the zero sequence base reach of the relay in line-to-neutral ohms.

The reach of the relay is inversely proportional to the voltage restraint tap setting. The maximum reach of the relay (30 or 150 ohms depending upon the relay rating) is obtained with the suggested minimum restraint tap setting of ten percent.

ANGLE OF MAXIMUM REACH

The relay base reach angle is adjustable by means of links on the rear of the unit. The positive sequence base reach angle can be set for either 85 or 75 degrees; the zero sequence base reach angle can be set for either 75 or 65 degrees.

The polarizing quantity used to develop the mho characteristic can be phase shifted relative to the operating quantity. The phase shift can be set for either zero or fifteen degrees lead. The fifteen degree setting results in a clockwise shift in the angle of maximum reach away from the base reach angle. The angle of maximum reach is equal to the base reach angle minus the polarizing phase shift. The fifteen degree setting increases the reach at the relay angle of maximum reach by the factor  $1/\cos(15^\circ)$  which is equal to 1.035.

PHASE ANGLE MEASUREMENT

The quantities  $I_Z$ ,  $-TV$ , and  $V_{p01}$  are supplied to a summing amplifier-filter card. This card sums  $I_Z$  and  $-TV$  and filters extraneous frequencies from the quantities  $(I_Z-TV)$  and  $V_{p01}$ . Each of the resulting signals is then amplified to produce two square wave outputs. The square waves are applied to a coincidence logic circuit which establishes the coincidence of the same instantaneous polarity of the square waves. The output of the coincidence logic is a rectangular pulse with a duration which is proportional to the phase angle between  $(I_Z-TV)$  and  $V_{p01}$ . A square wave derived from the zero sequence quantity  $K_0 I_0 Z$  is also supplied to the coincidence logic card and supervises the coincidence measurement.

The coincidence logic output is applied to a timing circuit which produces an output whenever the pulse width exceeds a preset duration. If the timer is set for 90 degrees (4.17 milliseconds on a 60 Hz base, 5.0 milliseconds on a 50 Hz base) a circular R-X characteristic is obtained. If the timer is set for less than 90 degrees, an expanded circle (tomato shaped) characteristic is obtained. If the timer is set for more than 90 degrees, a contracted circle (lens shaped) characteristic is obtained.

ZERO SEQUENCE CURRENT COMPENSATION

Zero sequence current compensation is provided as an integral part of each relay. The compensating factor ( $K_0$ ) must be set equal to the ratio of the zero impedance to the positive sequence impedance of the protected line ( $Z_0/Z_1$ ). The selection of the value of the  $K_0$  setting is discussed in the CALCULATION AND CHOICE OF SETTINGS section of this book.

CALCULATION AND CHOICE OF SETTINGS

Assume that the line to be protected is approximately 70 miles long and has primary impedances as follows:

$$Z_1' = 42 \angle 83^\circ, Z_0' = 130 \angle 78^\circ$$

Assume CT ratio is 1000/5 and PT ratio is 2000/1.

$$Z_1 \text{ sec} = 42 \left( \frac{1000}{5} \right) \left( \frac{1}{2000} \right) = 4.2 \angle 83^\circ$$

$$Z_0 \text{ sec} = 130 \left( \frac{1000}{5} \right) \left( \frac{1}{2000} \right) = 13 \angle 78^\circ$$

For short to medium length lines, that is, lines that are under 100 miles long, the SLYG61A relay is set as follows:

- (a) The positive and negative sequence base reach angle is selected based on the positive sequence impedance angle of the line; for line angles above 80 degrees, select the 85 degree base reach angle tap. For line angles 80 degrees and below, select the 75 degree base reach angle tap. For the sample line, select the 85 degree tap.
- (b) The zero sequence base reach angle tap is selected at 75 degrees if the zero sequence line impedance angle is above 70 degrees. Select the 65 degree tap if the line impedance angle is 70 degrees and below. For the sample line, select the 75 degree tap.
- (c) A typical relay reach setting ( $Z_R$ ) for the sample line would be 85 percent of the positive sequence line impedance ( $Z_{1L}$ ). For the sample line the relay reach would be 0.85 (4.2) or 3.57 ohms.

The positive and negative sequence base reach tap ( $Z_{R1}$ ) is typically selected to be as large as possible, but still less than the relay reach. This gives the maximum current sensitivity. The positive and negative sequence base reach tap ( $Z_{R1}$ ) is the product of two factors: the basic ohmic tap (BOT) and the base reach multiplier (BRM). The basic ohmic taps available are one and three ohms; the base reach multiplier taps are 0.1, 0.2, 0.5 and 1.0. The available base reach settings are given in the following table:

$Z_{R1}$	BOT	BRM
0.1	1	0.1
0.2	1	0.2
0.3	3	0.1
0.5	1	0.5
0.6	3	0.2
1.0	1	1.0
1.5	3	0.5
3.0	3	1.0

For the sample line, the suggested base reach ( $Z_{R1}$ ) is three ohms. This results from a BOT of three ohms and a BRM of 1.0.

- (d) After  $Z_{R1}$  has been selected, T, the restraint tap setting, can be calculated in accordance with the formula:

$$Z_R = \frac{Z_{R1}}{T} \quad \text{or} \quad T = \frac{Z_{R1}}{Z_R}$$

For the sample line  $T = \frac{3}{3.57} = 0.84$  or 84 percent

- (e)  $Z_{R0}$ , the zero sequence base reach, multiplied by the  $K_0$  multiplier, provides the "replica impedance" for the zero sequence impedance of the line.  $Z_{R0} = (BOT_0) (BRM)$ , where the  $BOT_0$  taps have the same ohmic value as BOT, one ohm and three ohms. BRM for the zero sequence base reach tap is set by the same taps as the BRM for the positive sequence base reach.  $K_0$  is adjustable from one to 10.9 in steps of 0.1. The desired zero sequence reach setting is 0.85 ( $Z_{0L}$ ) or  $0.85 (13) = 11.05$  ohms for the sample line. Typically  $Z_{R0}$  has the same value as  $Z_{R1}$ , that is  $BOT_0$  is selected equal to BOT or three ohms, the BRM has already been established as 1.0.  $K_0$  can be calculated as follows if  $Z_{R0} = Z_{R1}$ :

$$K_0 = \frac{Z_{0L}}{Z_{1L}} = \frac{13}{4.2} = 3.095 \quad \text{Use 3.1}$$



The zero sequence reach setting is  $\frac{K_0 Z_{RO}}{T} = \frac{3.1 (3)}{0.84} = 11.07$  ohms. This is very close to the desired reach setting and hence  $K_0 = 3.1$  is appropriate.

- (f) The phase shift tap is typically set on the zero degree tap for normal applications involving lines less than 100 miles long.
- (g) For lines less than 100 miles long the characteristic timer setting is typically the factory setting, namely, 120 degrees, 90 degrees/110 degrees. For 60 Hz applications, this is approximately 5.5, 4.2/5 milliseconds, and 6.6, 5/6 milliseconds at 50 Hz.
- (h) The factor  $T_0 K_0 Z_{RO}$  should be less than  $Z_0$  secondary of the line plus the minimum zero sequence source impedance at the remote end of the line. Select the maximum  $T_0$  tap that meets this requirement. For the maximum  $T_0$  tap, (0.4),  $T_0 K_0 Z_{RO} = 0.4 \times 3.1 \times 3 = 3.72$ , which is much less the zero sequence impedance of the line by itself (13 ohms).

Longer lines, such as those over 100 miles long, and particularly those with heavy load transfer may require modification of the settings for optimum performance. Refer to the nearest General Electric Company Sales Office for suggested setting modifications.

#### CONSTRUCTION

The type SLYG61A relay is packaged in a metal enclosure designed for mounting on a 19 inch rack. The relay is two rack units high (one rack unit is 1-3/4 inches). The outline and mounting dimensions are shown in Fig. 1. The relay contains the magnetics and tap blocks for setting the base reach and the percent restraint. It also contains the printed circuit cards for developing three ground mho characteristics. The relay has a hinged front cover and a removable top cover.

The setting of the basic ohmic tap is accomplished by the connection of the input currents to the GC terminal board on the rear of the relay. The connection points for the basic ohmic taps are shown in the table on the internal connection diagram of Fig. 2.

The voltage restraint tap blocks are located on the front of the unit at the left-hand side. Refer to the component location diagrams of Fig. 3. The voltage restraint tap settings are made by jumpers with taper tip pins on the end. In the accessory kit accompanying each equipment there are two special tools supplied for use with these pins. One is an insertion tool and the other is an extraction tool. In order to achieve a proper connection and to prevent damage to the pins, it is essential that these tools be used. Two tap blocks are used per phase: one is for the ten percent tap and one is for the one percent tap. The voltage restraint tap setting is the sum of the one and ten percent settings.

The relay also contains printed circuit cards which are located to the right of the tap blocks. The printed circuit cards are identified by a code number such as F126, C106, T133 or P102 where F designates filter, C designates coincidence, T designates time delay, and P designates processing. The printed circuit cards plug in from the front of the unit. The sockets are identified by letter designations or "addresses" (D, E, F etc.) which appear on the guide strips in front of each socket, on the component location diagram, on the internal connection diagram and on the printed circuit card itself.

#### RECEIVING, HANDLING AND STORAGE

These relays will normally be supplied as a part of a static relay equipment, mounted in a rack or cabinet with other static relays and test equipment. Immediately upon receipt the static relay equipment should be unpacked and examined for any damage sustained in transit. If injury or damage resulting from rough handling is evident, file a damage claim at once with the transportation company and promptly notify the nearest General Electric Sales Office.

Reasonable care should be exercised in unpacking the equipment. If the equipment is not to be installed immediately, it should be stored indoors in a location that is free from moisture, dust, metallic chips and severe atmospheric contaminants.

Just prior to final installation the shipping support bolt should be removed from each side of all relay units, to facilitate possible future unit removal for maintenance. These shipping support bolts are approximately eight inches back from the relay unit front panel. Static relay equipment, when supplied in swing rack cabinets, should be securely anchored to the floor or to the shipping pallet to prevent the equipment from tipping over when the swing rack is opened.

INSTALLATION TESTSCAUTION

THE LOGIC SYSTEM SIDE OF THE DC POWER SUPPLY USED WITH MOD III STATIC RELAY EQUIPMENT IS ISOLATED FROM GROUND. IT IS A DESIGN CHARACTERISTIC OF MOST ELECTRONIC INSTRUMENTS THAT ONE OF THE SIGNAL INPUT TERMINALS IS CONNECTED TO THE INSTRUMENT CHASSIS. IF THE INSTRUMENT USED TO TEST THE RELAY EQUIPMENT IS ISOLATED FROM GROUND, ITS CHASSIS MAY HAVE AN ELECTRICAL POTENTIAL WITH RESPECT TO GROUND. THE USE OF A CONNECTION TO THE EQUIPMENT, SUCH AS A TEST LEAD INADVERTENTLY DROPPING AGAINST THE RELAY CASE, MAY CAUSE DAMAGE TO THE LOGIC CIRCUITRY. IT IS A GOOD TEST PROCEDURE TO CONNECT THE REFERENCE LEAD OF A TEST INSTRUMENT TO RELAY REFERENCE BEFORE CONNECTING THE SIGNAL LEAD.

GENERAL

The test points (TP1, TP2, etc.) shown on the internal connection diagram are connected to instrument test jacks on a test card in card location T. TP1 is located at the top of the card and is connected to relay reference. TP10 is located at the bottom of the card and is connected to +15 VDC. Output signals are measured with respect to the relay reference (TP1). Logic signals are approximately +15 VDC for the ON or LOGIC ONE condition, and between zero and + one VDC for the OFF or LOGIC ZERO condition. Filter card outputs are square waves which shift from +15V to -15V.

Any of the input/output pins on the printed boards can be monitored by using the test card adapter as described in the printed circuit card instruction book GEK-34158. The logic signals can be monitored with an oscilloscope, a portable high impedance voltmeter or the voltmeter on the equipment test panel. When the test panel meter is supplied, it will normally be connected to relay reference. Placing the test lead to the proper test point will connect the meter for testing. When time-delay cards are to be adjusted or checked, an oscilloscope which can display two traces simultaneously and which has a calibrated horizontal sweep should be used.

The relay contains printed circuit cards with trimmer potentiometers mounted on them. Some of these potentiometers are factory set and sealed. These potentiometers should not be readjusted.

Before testing the relay, the trip outputs from the associated type SLAT relay should be opened to prevent inadvertent tripping of the breakers.

Input currents and voltages may be supplied to the relay through Type XLA test plugs placed in the test receptacles on the equipment test panel. Reference to the elementary diagram for the static relay equipment will provide information concerning equipment inputs. All units of a given terminal have been calibrated together at the factory and will have the same summary number on the unit nameplates. These units should be tested and used together.

NECESSARY ADJUSTMENTS

The following checks and adjustments should be made by the user in accordance with the procedures give under DETAILED TESTING INSTRUCTIONS before the relay is put into service. The necessary set points may be calculated following the procedures under CALCULATION AND CHOICE OF SETTINGS. The adjustments should be made in the order shown.

1. Base reach setting (BR)
  - a) Basic ohmic tap selection (BOT)
  - b) Base reach multiplier selection (BRM)
2. Voltage restraint tap setting (T)
3. Angle of maximum reach setting.
  - a) Positive sequence base reach angle
  - b) Zero sequence base reach angle
  - c) Polarizing voltage phase shift
4. Zero sequence current compensation setting ( $K_0$ )

5. Characteristic timer setting
6. Overall check of the MG1 function

DETAILED TESTING INSTRUCTIONS

$T_0 I_0 Z_{RO}$  MAGNITUDE AND ANGLE

The magnitude of the  $T_0 I_0 Z_{RO}$  quantity is adjusted by means of the  $T_0$  plug on the G card.  $T_0$  may be set for 0.0, 0.1, 0.2, 0.3 or 0.4. It is shipped from the factory in the 0.4 position. The angle of the  $T_0 I_0 Z_{RO}$  quantity is not adjustable. Note: On the earlier versions of this relay, the angle was adjustable. On these relays the phase shift adjustment plug should be set to the position marked 60 on the board (this is a zero-degree phase shift)

BASE REACH SETTING

The basic ohmic tap (BOT) is determined by the terminals to which the relay input currents are connected to the unit. The correct input terminals for the various taps are given in Table I.

TABLE I

CURRENT TAP	$I_A$		$I_B$		$I_C$		$(I_A + I_B + I_C)$	
	IN	OUT	IN	OUT	IN	OUT	IN	OUT
1 OR 5 OHM	GA4	GB8	GA6	GB9	GA8	GB10	GA10	GB11
3 OR 15 OHM	GA3	GB8	GA5	GB9	GA7	GB10	GA9	GB11

The base reach multiplier selector is located on the card in location E. The adjustment is accomplished by a four position jumper block. In each position the gain of the IZ circuit for each phase is set to the proper value of base reach multiplier. The base reach multiplier for each jumper position on the card is shown in Table II. The relay base reach is given by equation 1.

TABLE II

JUMPER POSITION	BASE REACH MULTIPLIER (BRM)
B	1.0
C	0.5
D	0.2
E	0.1

VOLTAGE RESTRAINT TAP SETTING

The voltage restraint tap setting (T) is accomplished on tap blocks located on the front of the relay. Two separate tap blocks are provided for each phase pair. The setting consists of a ten percent tap and a one percent tap. A restraint tap setting of 57 percent would consist of a ten percent setting of 50 and a one percent setting of seven. Only the special tools supplied with the relay should be used to change the tap setting.

ANGLE OF MAXIMUM REACH SETTING

The positive and zero sequence base reach angles are adjusted by means of links on the rear of the relay. The positive sequence base reach angle can be set for 75 degrees or 85 degrees. The zero sequence base reach angle can be set for 65 degrees or 75 degrees.

In order to set the polarizing voltage phase shift, it is necessary to adjust the X option plug on the filter cards in card locations H, J and K. The setting must be made on each of the three cards. The polarizing voltage phase shift for each position is shown in Table III.

TABLE III

PLUG X SHORTING ARRANGEMENT	DEGREES OF LEADING PHASE SHIFT
2 to 3 and 4 to 5	0
1 to 2 and 3 to 4	15

The polarizing phase shift may be checked and, if necessary, adjusted by using the test circuit of Fig. 5 and the appropriate connections of Table IV. Note that only voltage is applied to the relay for this test. The following procedure is recommended:

- 1) Start with the phase A connections of table. Set the voltage restraint tap for 100 percent. Adjust the voltage for 30 V rms.

TABLE IV

PHASE	FIGURE 5 CONNECTIONS 1 OR 5 OHM TAP					OUTPUT
	A	B	C	D	E Through H	
A	GB2	GB4	GB6	**	NO CONNECTION	TP5
B	GB4	GB6	GB2	**	NO CONNECTION	TP7
C	GB6	GB2	GB4	**	NO CONNECTION	TP9

\*\*Jumper GB3, 5 and 7 to point D.

- 2) Observe the output at pins 8 and 9 of the filter card in location, H for phase A. The following phase angle measurements should be made using a dual trace oscilloscope with a calibrated sweep sufficiently fast to provide an accurate measurement, and with both traces carefully zeroed on the center line. Refer to Fig. 6 for sample waveforms.
- 3A) Zero Degree Polarizing Phase Shift  
The square waves at pins 8 and 9 of the filter card should be exactly 180 degrees out of phase, i.e., the zero crossings of each trace should coincide at the center line and the traces should have opposite slopes. The phase shift between pin 8 and pin 9 may be adjusted by potentiometer P71 on the filter card.
- B) Fifteen Degree Polarizing Phase Shift  
The square wave at pin 9 is now shifted 15 degrees in the leading direction (toward the left-hand edge of the screen). The zero crossings of the square waves should now occur 15 degrees apart (0.694 milliseconds on a 60 Hz base, 0.833 milliseconds on a 50 Hz base). Refer to Fig. 6. The phase shift between pins 8 and 9 may be adjusted by potentiometer P71 on the filter card.
4. Repeat steps 1, 2 and 3 for phase repairs B and C. Observe the outputs of the filter card associated with the phase under test. Use the appropriate connections from Table IV.

ZERO SEQUENCE CURRENT COMPENSATION SETTING

The zero sequence current compensation setting ( $K_0$ ) is adjusted by means of two thumb-wheel switches mounted on the card in position G.

The upper switch (S10) selects the unit value and is adjustable from one to ten in integer steps. The lower switch (S11) selects the tenths value and is adjustable from 0.0 to 0.9 in one tenth increments. The zero sequence current compensation setting is the sum of the settings on the two switches. The setting may be read directly from the positions of the two switches.

CHARACTERISTIC TIMER SETTING

The pickup setting of the characteristic timer affects the shape of the MG1 characteristic as plotted on an R-X diagram. Increasing the pickup time narrows the characteristic, decreasing the pickup time widens the characteristic. The reset time delay (dropout time) provides an overlap of the next half cycle measurement. The inputs to the characteristic timers are chains of pulses (one per half cycle) from the coincidence logic cards. The outputs of the timers are DC logic signals. The timer settings are discussed in the section CALCULATION AND CHOICE OF SETTINGS.

The timers used for the MTG function are integrating characteristic timers. These timers are typically listed on the overall logic as T1, T2/T3 where T1 is the pickup time in milliseconds on a step DC input, T2 is the pulse width which will cause the timer to pick up with one pulse applied per half cycle and T3 is the dropout delay. The operation of the integrating characteristic timers is discussed in the printed circuit card instruction book, GEK-34158.

The DC pickup (T1) and the dropout (T3) of the MTG characteristic timer may be set using the test circuit of Fig. 4. Before testing the timer with this circuit, the card which normally supplies the input to the timer must be removed (refer to Table V). Opening the normally closed contact of Fig. 4 causes the output to step to +15VDC after the pickup delay of the timer. To increase the pickup delay, turn the upper potentiometer (P1) on the timer card clockwise. Closing the contact causes the timer to drop out (step to less than one VDC) after the reset delay setting of the card. To increase the reset delay, turn the second potentiometer (P2) clockwise. The pulse pickup mode of the timer may be observed while plotting the characteristic as described in OVERALL CHECK OF THE MTG CHARACTERISTIC. The applied voltage and current as well as the phase angle between them, can be adjusted to vary the pulse width of the timer input.

TABLE V

PHASE	TIMER UNDER TEST	REMOVE CARD
A	P	L
B	R	M
C	S	N

OVERALL CHECK OF THE MTG FUNCTION

The test circuit of Fig. 5 should be used to check the operation of the MTG function. Use the connections of Table VI for the one or five basic ohmic tap or Table VII for the three or fifteen ohm basic ohmic tap.

TABLE VI

PHASE	FIGURE 5 CONNECTIONS 1 OR 5 OHM TAP								OUTPUT
	A	B	C	D	E	F	G	H	
A	GB2	GB4	GB6	**	GA4	GB8	GA10	GB11	TP5
B	GB4	GB6	GB2	**	GA6	GB9	GA10	GB11	TP7
C	GB6	GB2	GB4	**	GA8	GB10	GA10	GB11	TP9

\*\*Jumper GB3, 5 and 7 to point D.

TABLE VII

PHASE	FIGURE 5 CONNECTIONS 3 OR 15 OHM TAP								OUTPUT
	A	B	C	D	E	F	G	H	
A	GB2	GB4	GB6	**	GA3	GB8	GA9	GB11	TP5
B	GB4	GB6	GB2	**	GA5	GB9	GA9	GB11	TP7
C	GB6	GB2	GB4	**	GA7	GB10	GA9	GB11	TP9

\*\*Jumper GB3, 5 and 7 to point D.

Base Reach Angle and Reach Check

The base reach angle is a function of the positive sequence base reach angle, the zero sequence base reach angle, and the zero sequence current compensation factor. The nominal base reach angles for this

test configuration are given in Table VIII for various combinations of base reach angles and zero sequence current compensation settings ( $K_0$ ). If a  $K_0$  setting other than one in the table is used, the base reach angle can be found by interpolation.

TABLE VIII

$K_0$ TAP	POS. SEQ. SET	85°	85°	75°	75°
	ZERO SEQ. SET	75°	65°	75°	65°
1	Nominal base reach angles are for test circuit of Figure 5 ( $I_1 = I_0$ )	81.7°	78.4°	75°	71.7°
3		79.0°	73.0°	75°	69.0°
5		77.8°	70.7°	75°	67.8°
7		77.2°	69.4°	75°	67.2°
9		76.8°	68.6°	75°	66.8°
10.9		76.5°	68.1°	75°	66.5°

The following procedure is recommended to check the base reach angle (A) and the relay reach setting.

- 1) Use the test circuit of Fig. 5 starting with the phase A connections from Table VI or VII.

Set the test current for a current equal to or greater than that specified in Table IX. Currents greater than twice rated should not be continuously applied to the relay. Currents greater than four times rated should not be applied to the relay. Currents between two and four times rated should not be applied longer than five minutes with an off time of at least five minutes.

Note that the minimum currents of Table IX are for  $K_0 = 1$ ; for larger values of  $K_0$ , the minimum currents for each base reach is lower. Refer to the SENSITIVITY section of this book for further information.

TABLE IX

BASE REACH OHMS	RECOMMENDED MINIMUM TEST CURRENT (AMP) FOR LESS THAN 3% PULL BACK ( $K_0=1$ )	
	5 AMPERE RELAY	1 AMPERE RELAY
3.0	2	0.4
1.5	5	1.0
1.0	10	2.0
0.6	10	2.0
0.5	20	4.0
0.3	20	4.0
0.2	20**	4.0**
0.1	20**	4.0**

\*\*Less than 10 percent pull back.

- 2) Adjust the phase angle for the nominal base reach angle as found from Table VIII.
- 3) Observe the output at pin 8 of the appropriate filter card (card location H for A phase, J for B phase or K for C phase).

- 4) Lower the voltage to the value given by the following expression:

$$V = \left( \frac{2 + K_0}{3} \right) \times I \times \text{BOT} \times \text{BRM} \times \frac{100}{T} \quad (\text{Eq 4})$$

where:

- V is the pickup voltage at the base reach angle
- BOT is the basic ohmic tap in ohms
- BRM is the base reach multiplier
- I is the test current (one or five amperes)
- $K_0$  is the zero sequence current compensation setting
- T is the voltage restraint tap setting in percent

- 5) As the voltage is lowered, observe the output of the MTG function: TP5 for phase A, TP7 for B and TP9 for C. At the point where MTG picks up, a slight adjustment of the phase angle and voltage should cause the square wave at pin 8 of the filter card to come out of saturation. A further adjustment will cause the signal at pin 8 to be reduced to a null voltage consisting only of third and fifth harmonics. The angle on the phase angle meter is the base reach angle and should be within two degrees of nominal. The voltage should be within five percent of the value given by equation 4.
- 6) A vernier adjustment on the reach is provided on the filter card (position H, J and K). Turning P10 on the filter card clockwise increases the voltage required to null the MG1 function, thereby increasing the relay reach.
- 7) Repeat steps 1 through 6 for the phases B and C using the appropriate connections from Table VI or VII.

#### Complete MTG Function Check

The following procedure is recommended to provide an overall check of all the adjustments included in the MTG function. It is only necessary to check the relay reach at two angles other than the base reach angle.

- (1) Use the test circuit of Fig.5 and the phase A connections from Table VI and VII. Set the current for the desired test level (Table IX); monitor the output at the TP5 for a A phase, TP7 for B phase or TP9 for C phase.
- 2A) Pickup for angles less than or equal to the base reach angle.
- a) Adjust the phase shifter to obtain a phase angle 30 degrees less than the base reach angle.
- b) Lower the applied voltage and check for an MTG output within five percent of the voltage given by the expression:

$$V_D = V_T \times \frac{\text{Sin } (D - A + B + 180 - C)}{\text{Sin } (B + 180 - C)} \quad (\text{Eq 5})$$

where:

- A is the base reach angle found in Table VIII
- $V_T$  is the pickup voltage at the base reach angle given by equation 4
- B is the polarizing voltage phase shift setting in degrees

- C is the characteristic timer setting in degrees. For 50 Hz relays multiply the timer setting in milliseconds by 18 to obtain degrees; for 60 Hz relays multiply by 21.6.
- D is the phase angle meter reading (voltage leading current)

2B) Pickup for angles greater than the base reach angle

- a) Adjust the phase shifter to obtain a phase angle 30 degrees greater than the base reach angle.
- b) Lower the applied voltage and check for an MG1 output within five percent of the voltage given by the expression:

$$V_D = V_T \times \frac{\sin (D - A + B + C)}{\sin (B + C)} \quad (\text{Eq 6})$$

### PERIODIC CHECKS AND ROUTINE MAINTENANCE

#### PERIODIC CHECKS

The MTG functions included in the relay may be checked at periodic intervals using the procedures described under OVERALL CHECK OF THE MG1 FUNCTION. By checking the reach of each unit at the base reach angle and one angle either side of the base reach angle, all settings of the MTG functions may be verified.

#### TROUBLESHOOTING

In any troubleshooting equipment, it should first be established which unit is functioning incorrectly. The overall logic diagram supplied with the equipment shows the combined logic of the complete equipment and the various test points in each unit. By signal tracing, using the overall logic diagram and the various test points, it should be possible to quickly isolate the trouble.

A test adapter card (0149C7259G-2) is supplied with each static relay equipment to supplement the pre-wired test points on the test cards. Use of the adapter card is described in the card instruction book GEK-34158.

A dual-trace oscilloscope is a valuable aid to detailed troubleshooting, since it can be used to determine phase shift, operate and reset times as well as input and output levels. A portable dual-trace oscilloscope with a calibrated sweep and trigger facility is recommended.

#### SPARE PARTS

To minimize possible outage time, it is recommended that a complete maintenance program should include the stocking of at least one spare card of each type. It is possible to replace damaged or defective components on the printed circuit cards, but great care should be taken in soldering so as not to damage or bridge-over the printed circuit buses, or overheat the semi-conductor components. The repaired area should be recovered with a suitable high-dielectric plastic coating to prevent possible breakdowns across the printed buses due to moisture and dust. The wiring diagrams for the cards in the relay are included in the card book GEK-34158; the card types are shown on the component location diagram, Fig. 3.

#### TERMS

- BOT - Basic Ohmic Tap (ohms line-to-neutral)
- BR - Base Reach (ohms line-to-neutral)
- BRM - Base Reach Multiplier



- $K_0$  - Zero Sequence Current Compensation Setting  
( $Z_0/Z_1$ ) in per unit
- T - Voltage Restraint Tap in Percent
- B - Polarizing Voltage Phase Shift in Degrees
- A - Base Reach Angle
- $Z_A$  - Relay Reach at Base Reach Angle
- C - Characteristic Timer Setting in Degrees

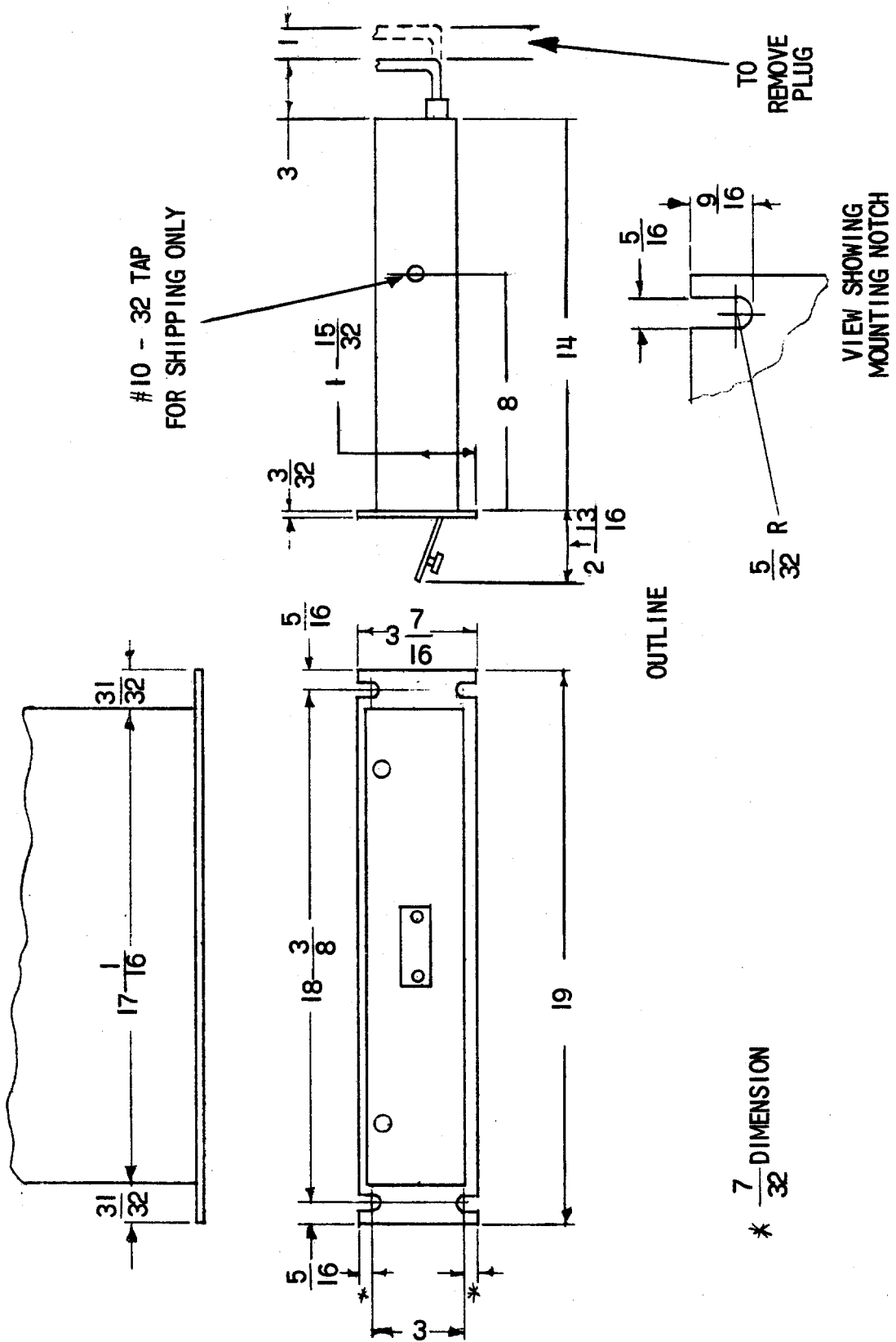

Fig. 1 (0227A2036-0) Outline and Mounting Dimensions for the SLYG61A Relay

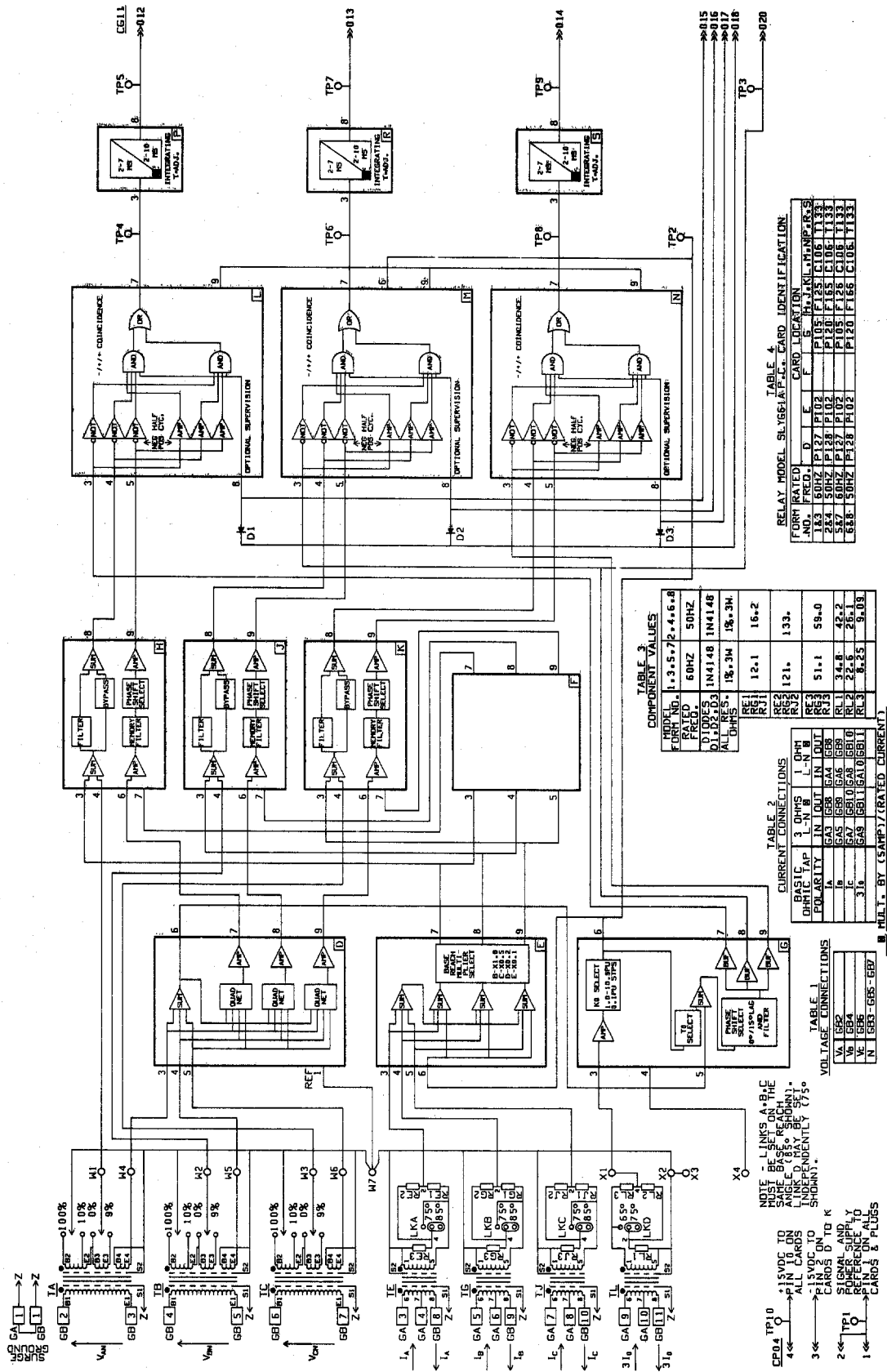
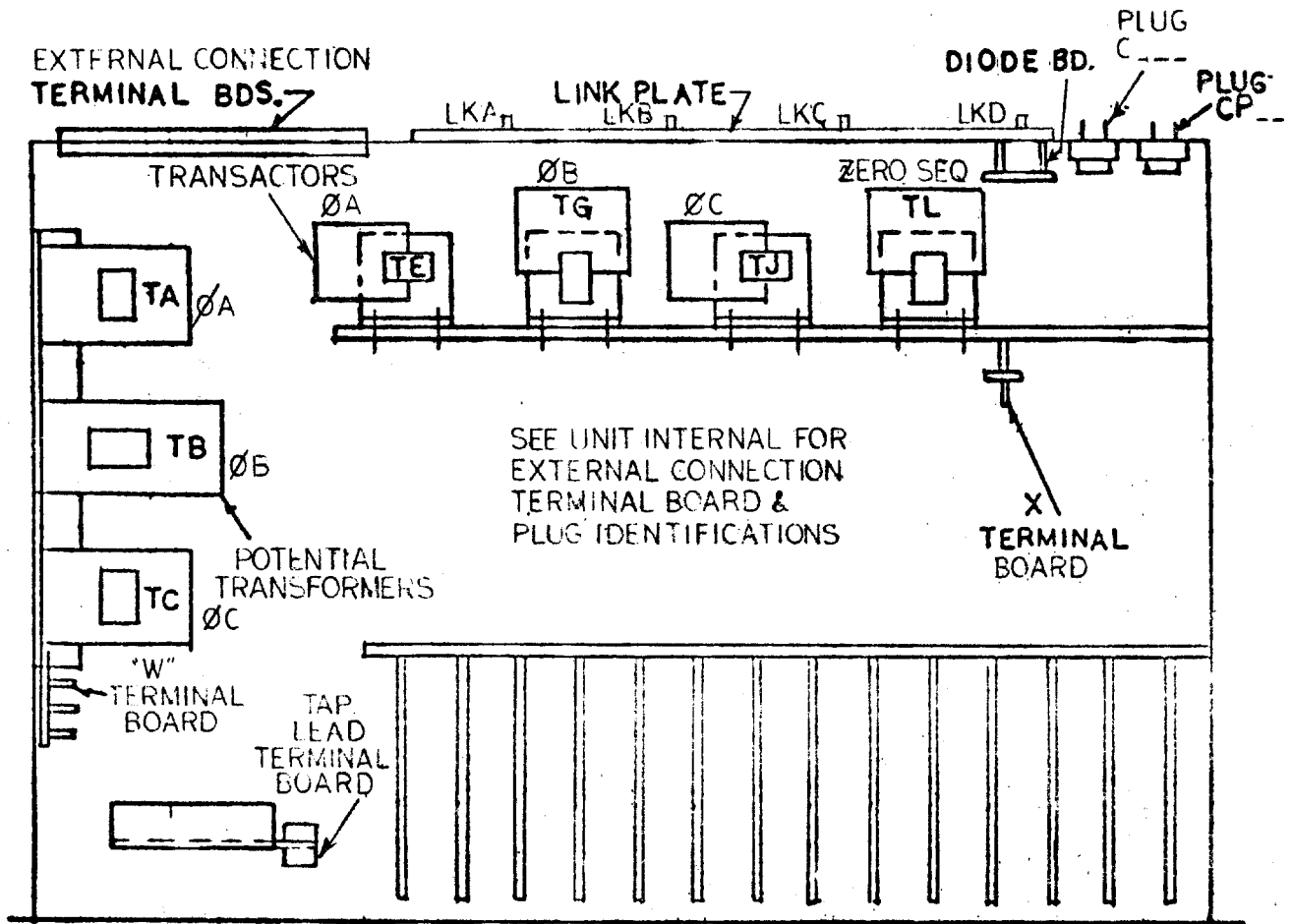
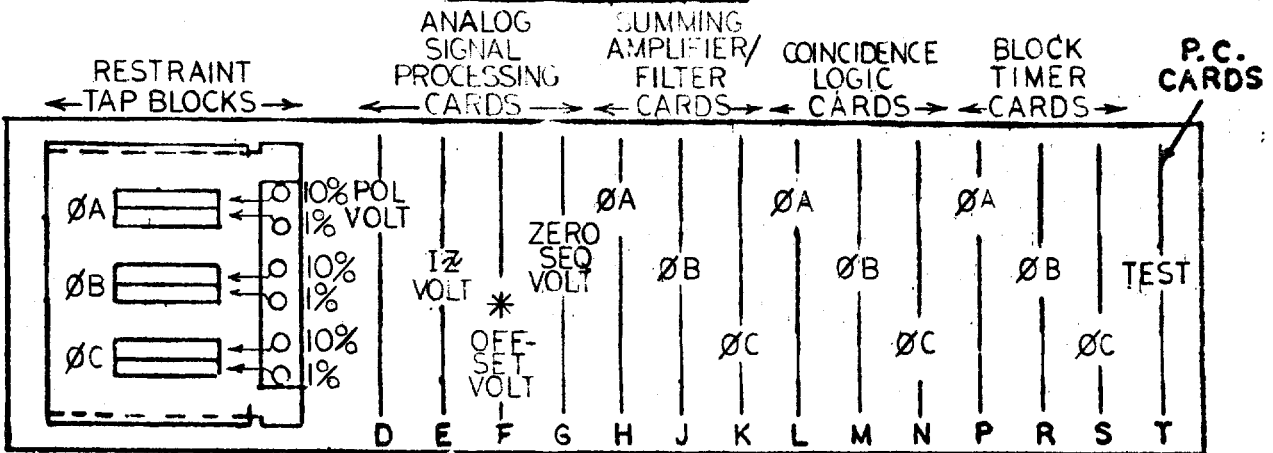

Fig. 2 (0136D5011-0) Internal Connections Diagram for the SLYG61A Relay



**PLAN VIEW**

FRONT



**FRONT VIEW**

\* WHEN USED. SEE UNIT INTERNAL FOR P.C. CARD LOCATIONS.

Fig. 3 (0269A3158-1) Component Location Diagram for the SLY661A Relay

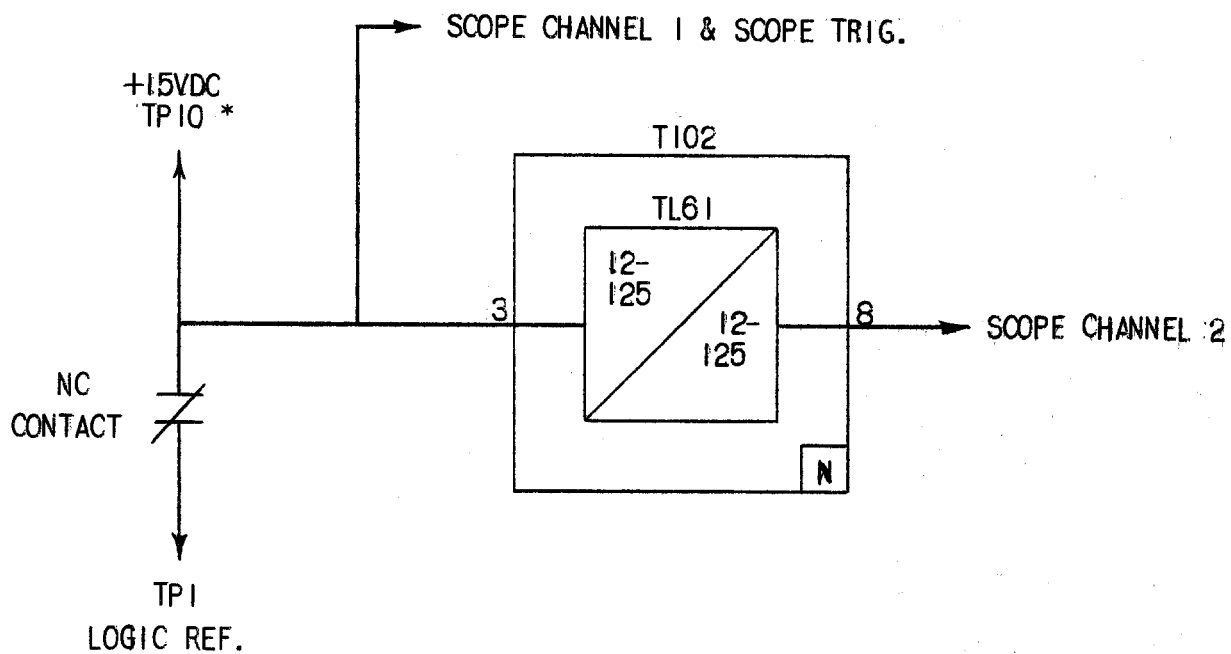

\* THE 15VDC SIGNAL AT PIN 10 HAS A CURRENT LIMITING RESISTOR MOUNTED ON THE TEST CARD.

Fig. 4 (0246A7987-0) Timer Test Circuit

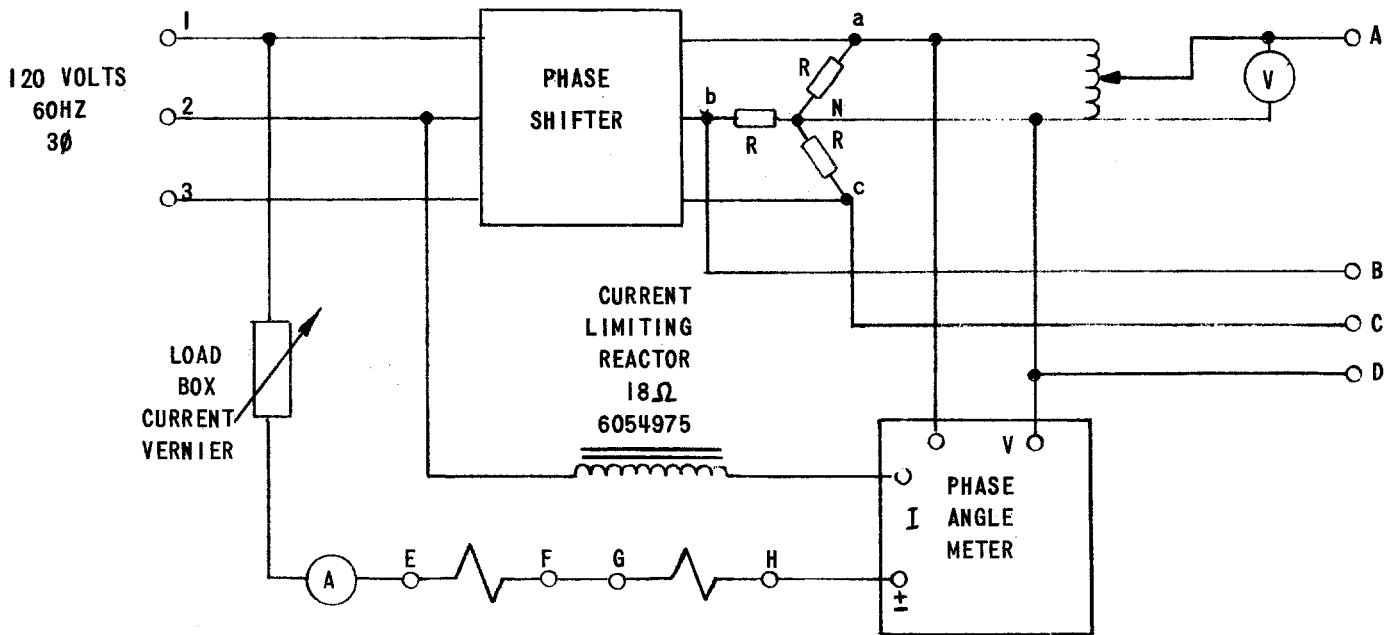

$R = \text{APPROX. } 100 \Omega \text{ (100W)}$   
 (ADJUST THE VALUE OF THE R'S SO THAT  $V_{A-N} = V_{B-N} = V_{C-N}$ )

Fig. 5 (0246A6530-2) MG1 Function Test Circuit

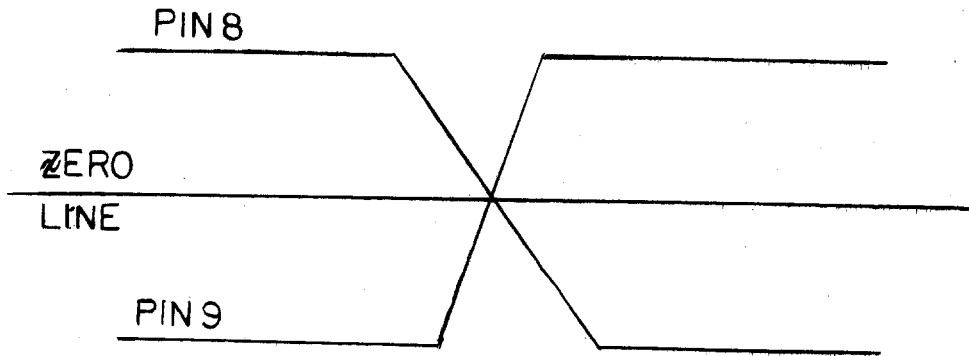

PROPERLY SET 0 DEGREE PHASE SHIFT

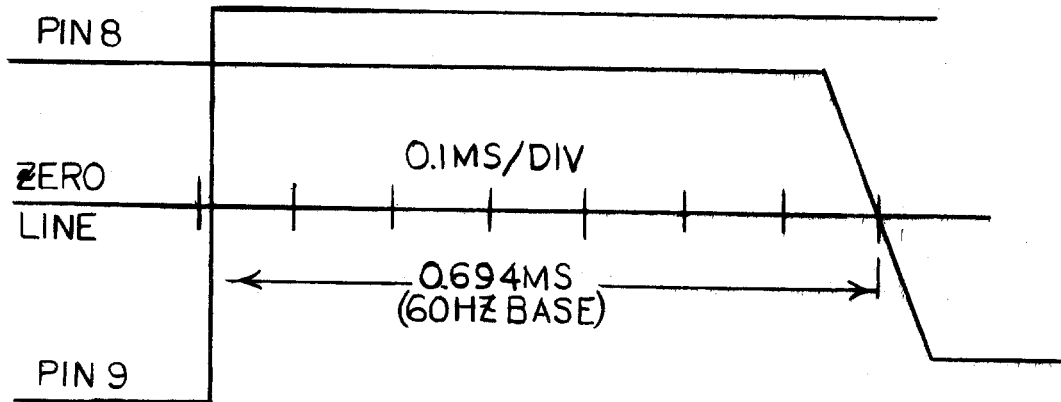

PROPERLY SET 15 DEGREE PHASE SHIFT

Fig. 6 (0257A9696-1) Polarizing Circuit Phase Shift Waveforms

**GENERAL ELECTRIC COMPANY  
POWER SYSTEMS MANAGEMENT BUSINESS DEPT.  
PHILADELPHIA, PA. 19142**

**GENERAL  ELECTRIC**