



INSTRUCTIONS

STATIC PILOT WIRE RELAY

TYPE SPD11A

These instructions do not purport to cover all details or variations in equipment nor provide for every possible contingency to be met in connection with installation, operation or maintenance. Should further information be desired or should particular problems arise which are not covered sufficiently for the purchaser's purposes, the matter should be referred to the General Electric Company.

To the extent required the products described herein meet applicable ANSI, IEEE and NEMA standards; but no such assurance is given with respect to local codes and ordinances because they vary greatly.

CONTENTS

	<u>PAGE</u>		<u>PAGE</u>
DESCRIPTION	3	ACCEPTANCE TESTS	17
APPLICATION	3	VISUAL INSPECTION	17
RATINGS	4	MECHANICAL INSPECTION	17
TEMPERATURE	4	ELECTRICAL TESTS	17
DIELECTRIC STRENGTH		INSTALLATION PROCEDURE	18
(AC HIGH-POTENTIAL TEST).....	4	LOCATION	18
SURGE-WITHSTAND CAPABILITY	4	GROUNDING	18
CURRENT CIRCUITS	4	VISUAL INSPECTION	19
DC CIRCUITS	4	MECHANICAL INSPECTION	19
OUTPUT CONTACTS	4	TELEPHONE RELAY	19
SEISMIC CAPABILITY	5	HIGH-SEISMIC TARGET/SEAL-IN UNIT	19
CURRENT TAPS	6	MECHANICAL CHECK	20
PHASE TAPS	6	ELECTRICAL TESTS - GENERAL	20
GROUND TAPS	6	DIELECTRIC TESTS	20
DC CONTROL-VOLTAGE TAPS	6	TESTS TO VERIFY SETTINGS	21
TARGET AND SEAL-IN UNIT		SYSTEM TESTS	24
PICKUP-CURRENT TAPS	6	PERIODIC TESTING AND	
RESTRAINT TAPS	6	ROUTINE MAINTENANCE	27
PILOT WIRE	6	CONTACTS	27
CHARACTERISTICS	7	ELECTRICAL TESTS	27
OPERATING PRINCIPLES	7	PILOT WIRE	28
PRINTED-CIRCUIT CARD	9	SERVICING	28
PICKUP TIME	10	GENERAL	28
DROPOUT TIME	10	CAUTION	29
PICKUP CURRENT VS.		ADDITIONAL CAUTION	29
PILOT-WIRE LENGTH	10	RECALIBRATION OF MIXING NETWORK..	29
BURDENS	10	RENEWAL PARTS	31
ONE-SECOND RATINGS	13	APPENDIX - PILOT WIRE PROTECTION ..	32
DC CONTROL BURDEN	13	INTRODUCTION	32
CALCULATION OF SETTINGS	13	MUTUAL-DRAINAGE REACTOR	33
CONSTRUCTION	15	NEUTRALIZING REACTOR	33
RECEIVING, HANDLING AND STORAGE ...	16	CONDUCTOR SHIELDING	34
		LIST OF ILLUSTRATIONS	38

LIST OF TABLES

Table I	Interrupting Ratings	5
Table II	Ratings and Characteristics of Target Seal-in Unit	5
Table III	Phase Faults	9
Table IV	Ground Faults	9
Table V(a)	Three Phase Faults or Loads, 60 Hertz	11
Table V(b)	Three Phase Faults or Loads, 50 Hertz	12
Table VI	Circuit Groups for Transverse-Mode Hipot Tests	21
Table VII	DC Current	22
Table VIII	Transactor-Output Voltage vs. Tap	30
Table IX	Voltage Across Ground Resistor	30
Table X	Mutual-Drainage Reactor	35
Table XI	Neutralizing Reactor	36
Table XII	Gas Protector Tube	37

STATIC PILOT WIRE RELAY

TYPE SPD11A

DESCRIPTION

The Type SPD relay is a high-speed static pilot wire relay that provides both phase- and ground-fault protection for all three phases of two-or three-terminal transmission lines. As shown in the block diagram of Figure 24, the relay includes the following: a current-sequence network that combines the currents from the three line-current transformers into a single quantity, a voltage-limiting unit to limit the magnitude of signals impressed on the pilot wires, a power supply, an isolation transformer, an electromechanical output relay, a target/seal-in unit, and a printed-circuit card.

The printed-circuit card includes voltage- and current-measuring functions, a summing function, a level-detecting function, a timing function and an output-driving function.

The relay is packaged in the medium-size, double-ended (M2) drawout case.

APPLICATION

The Type SPD relays provide high-speed protection for two-or three-terminal lines. A typical installation as shown in Figure 33 for a two-terminal line consists of two SPD relays, one at each line terminal, plus an interconnecting two-conductor metallic pilot-wire circuit, three current transformers (CTs) (one per phase) and DC power sources at each end. An AC pilot-wire current-measuring set consisting of an AC milliammeter, switch and meter transformer is supplied with the relay. It may be installed to permit monitoring of the pilot-wire currents on a periodic basis.

For a three-terminal line a typical installation consists of three SPD relays (one at each terminal), plus an interconnecting wye-connected pilot-wire circuit, padded if necessary, so that each branch has the same series resistance.

If the line to be protected is impedance grounded, the ground-fault current may be relatively small, below the level of the most-sensitive ground-current tap. For such installations, a ground-current sensor of proper ratio may be connected to terminals 13 and 14 of the SPD relay, providing greatly-improved sensitivity to ground-fault currents.

The maximum voltage for switchboard wiring is limited to 600 volts. The insulating transformer that is included in the SPD relay is designed to withstand voltages-to-ground up to 600 volts rms at terminals 18 and 19. If voltages due to

ground-potential rise or other causes exceed this value, measures should be taken as described in the Appendix (Pilot-Wire Protection) to reduce the voltage at the relay terminals.

Additional application information is available in publication GET-6462.

RATINGS

TEMPERATURE

These relays have been designed for continuous operation in ambient temperatures between -20°C and +55°C per ANSI Standard C37.90. In addition, these relays will not malfunction nor be damaged if operated in an ambient temperature up to 65°C.

DIELECTRIC STRENGTH (AC HIGH-POTENTIAL TEST)

For the purposes of dielectric tests, the SPD relay is rated 600 volts. Per ANSI/IEEE C37.90-1978, the high-potential test voltage is 2200 volts for one (1) minute. As described in the standard, relays other than new should be tested at 75% of this voltage. The surge-protective capacitors used in the SPD relay have **limited** AC-voltage ratings and the procedures described in **ACCEPTANCE TESTS** should be followed to avoid damaging them.

SURGE-WITHSTAND CAPABILITY

The SPD relay passes the surge-withstand capability of ANSI/IEEE C37.90-1978.

CURRENT CIRCUITS

The current circuits of the type-SPD relay are designed to carry 10 amperes at rated frequency continuously.

The phase-current circuits will withstand 250 amperes for one (1) second. The ground-current circuits (studs 3, 13 and 14) will withstand 125 amperes for one (1) second. These limitations are due to heating in the network resistors.

DC CIRCUITS

The type-SPD relay has a dual-rated power supply designed to operate at either of two DC control voltages. Models are available with ratings of 48/125 volts and 48/110 volts. The voltage range is selected by the DC-voltage tap located at the left of the upper tap block. The relay will operate properly with 80% to 112% of rated DC voltage. The 250 VDC relays use an external pre-regulator to reduce the voltage from 250 to 125 volts. The relay, therefore, must be set on the 125 volt DC links.

OUTPUT CONTACTS

The type-SPD relay has two electrically-separate normally-open output circuits. The output circuit connected to studs 1 and 11 has a high-seismic target/seal-in

unit. The output circuit connected to studs 2 and 12 has no target/seal-in unit. Each output circuit has contacts that will make and carry 30 amperes for tripping duty and 3 amperes continuously. The interrupting ratings are given in the following table:

TABLE I
INTERRUPTING RATINGS

AC VOLTS	AMPS	
	INDUCTIVE**	NON-INDUCTIVE
115	0.75	2.0
230	0.5	1.5
DC VOLTS		
48	1.0	3.0
125	0.5	1.5
250	0.25	1.0

** The inductive rating is based on an L/R ratio of 0.1 second.

The circuit with the target/seal-in unit will not attempt to interrupt if the current is sufficient to keep the target/seal-in picked up. In some cases the characteristics of the target/seal-in unit will limit the current rating of the circuit in which it is connected. The ratings and characteristics of the target/seal-in unit are given in Table II.

TABLE II
RATINGS AND CHARACTERISTICS OF TARGET/SEAL-IN UNIT

	TAP	
	0.2	2
DC Resistance \pm 10% (Ohms)	7	0.13
Minimum Operating (Amperes)	0.2	2.0
Carry Continuously (Amperes)	0.3	3.0
Carry 30 Amps for (Seconds)	0.03	4
Carry 10 Amps for (Seconds)	0.25	30
60 Hz Impedance (Ohms)	52	0.53
Minimum Dropout (Amperes)	0.05	0.5

SEISMIC CAPABILITY

The Seismic Fragility Level exceeds 3.5g ZPA when tested using a biaxial multi-frequency input motion to produce a Required Response Spectrum in accordance with ANSI/IEEE C37.98-1978, Standard for Seismic Testing of Relays.

CURRENT TAPS

These taps determine phase-current pickup. The current taps are located on the right of the upper tap block. The taps are labeled in terms of the balanced three-phase amperes required to pick up the relay (on tap C, with the pilot wire disconnected). The taps are 4, 5, 6, 7, 8, 10 and 12 amperes.

PHASE TAPS

These taps determine sequence mix. Unless unusual circumstances exist, the C tap should be used. The phase taps are located at the left of the lower tap block. They control the sensitivity to positive-sequence three-phase current with only a small effect on the phase-to-phase sensitivity. The C tap provides the lowest three-phase pickup, tap B provides twice as much, and tap A makes the relay insensitive to balanced three-phase current.

GROUND TAPS

These taps determine ground-current pickup. The ground taps are located at the right of the lower tap block. Tap H provides ground-current pickup of approximately one eighth (1/8) the setting of the current tap. Tap G provides ground-current pickup of approximately one fourth (1/4) the setting of the current tap. The ratio of ground-current sensitivity to current-tap setting is slightly influenced by the phase-to-phase tap. Tap F makes the relay insensitive to zero-sequence current.

DC-CONTROL-VOLTAGE TAPS

The DC-control-voltage taps are located at the left of the upper tap block. The two taps are labeled according to the relay rating. A movable dual link is used to set the relay for either of the two rated voltages. **Both** screws must be tightened in order to assure correct operation.

TARGET/SEAL-IN UNIT PICKUP-CURRENT TAPS

The target/seal-in unit taps are located on the right side of the target/seal-in unit and allow the selection of either of two trip-circuit pickup-current values. By using the procedure described in **ACCEPTANCE TESTS** the tap setting can be changed without disturbing the mechanical adjustment of the contacts.

RESTRAINT TAPS

The restraint taps, HI and LO, are located in the middle of the lower tap block. The normal setting is the HI position, which is to the left.

PILOT WIREGeneral

The pilot-wire loop resistance and shunt capacitance should be as low as possible and may not exceed the limits given below.

Two-Terminal Lines

The maximum pilot-wire loop resistance is 2000 ohms.

The maximum pilot-wire shunt capacitance is 1.5 microfarads.

For higher values consult the factory.

Three-Terminal Lines

The maximum pilot-wire loop resistance per leg is 500 ohms. The three leg loop resistances should be matched as closely as possible. One percent (1%) or less is recommended. Any mismatch will increase the tendency of the scheme to trip falsely on external faults. For example, a mismatch of 5% can produce a signal in one or more relays that is one quarter ($\frac{1}{4}$) of that required to cause a misoperation. The lower resistance legs may be padded if necessary with series resistors. Equal resistance should be put in each wire of a pair. The sum of the resistances of both wires between two locations is the loop resistance. The maximum total shunt capacitance is 1.8 microfarads.

Signal Level

The signal supplied by the relay to the pilot wire is limited to 60 volts by the voltage-limiting component. The pilot-wire current produced by the SPD relay will be below 100 milliamperes. This allows a telephone line to be used as the pilot wire.

CHARACTERISTICS

OPERATING PRINCIPLES

Pilot-wire relaying is a form of current-differential relaying. In current-differential relaying the currents entering and leaving the protected section are compared. Any difference indicates that some current is entering or leaving the protected section by an undesired path, that is, a fault. The currents are usually compared on a per-phase basis, with a separate relay for each phase. Current-differential relaying can be highly selective, sensitive, and fast in operation.

Pilot-wire relaying was developed to extend the concept of current-differential relaying to applications where the distance between the ends of the protected section is too great to allow current-transformer (CT) leads to run to a common location. To reduce the number of leads, all the currents at each location are combined into a single signal. This signal is conditioned so that it is suitable for application to a telephone-service-type wire pair (the pilot wire). The local signal is compared to the signal on the pilot wire, which is the result of the signals applied by both local and remote relays, to determine if there is a fault in the protected section.

In the SPD relay the input currents are combined by a network to produce a single-phase voltage that is applied to the pilot wire. The static circuitry measures the voltage and current in the pilot-wire circuit at the relay terminals.

When an external fault occurs, the voltages produced by both relays are equal in magnitude but opposite in polarity (refer to Figure 23a). The voltages add around the pilot-wire loop, and a relatively large current flows. The voltage at the relay pilot-wire terminals is low since the other relay opposes it. The static circuitry is designed to restrain under these conditions of low pilot-wire voltage and high pilot-wire current. This is also the condition that occurs during normal load flow, except that both the voltage and current magnitudes are lower.

When an internal fault occurs, the voltage at one end increases in magnitude, while at the other end the magnitude increases but the polarity reverses, (refer to Figure 23b). The two voltages now oppose current flow, and at each relay's pilot-wire terminals there is a large voltage and a small current. The static circuitry is designed to operate for this condition.

In the SPD relays the three-phase currents and ground currents are combined into a single signal by a network whose coefficients can be varied to suit the application. It is desirable to be able to vary the relay's sensitivity to balanced three-phase (positive-sequence) current for two reasons.

First, load current tends to restrain the relay for low-current faults. This tendency can be reduced by decreasing the relay's sensitivity to three-phase (positive-sequence) current. Of course, this also decreases the relay's sensitivity to three-phase faults, but if three-phase faults are detected by another relay, or if the three-phase fault current is always high, some reduction in three-phase sensitivity may be acceptable.

Second, in applications where the user is concerned about the pilot-wire being accidentally opened, which could cause a false trip, the relay three-phase-current pickup may be placed above maximum full-load current. The phase taps allow the three-phase-current sensitivity to be halved or reduced to zero with only a moderate effect on the phase-to-phase- and phase-to-ground-current sensitivity.

The effect of parallel (leakage) resistance between the wires of the pilot-wire pair is to increase the current required to cause the relays to operate. In the extreme case of a short circuit, none of the relays can be expected to trip; a series resistance in the pilot wire lowers the current required to pick up the relay. An open circuit will cause the relays to operate as overcurrent relays.

The tables on the following page give the pickup of the relay for each type of fault with each phase-tap and ground-tap setting in percent of the pickup for a three-phase fault with tap C. The tap positions available on the three-phase pickup-amperes tap block are 4, 5, 6, 7, 8, 10 and 12 three-phase amperes.

TABLE III
PHASE FAULTS

The value in the table is the pickup in percent of the pickup for a three-phase fault with tap C.

TYPE OF FAULT	PHASE TAP POSITION		
	A	B	C
A-B	100	90	86
B-C	100	65	53
C-A	100	90	86
3 ϕ	†	200	100

† The relay will not respond to balanced three-phase current in this tap.

TABLE IV
GROUND FAULTS

For all single-phase-to-ground faults, pickup on tap G is approximately 25% of ground tap, pickup on tap H is approximately 12.5% of ground tap.

On the F tap the relay is insensitive to zero-sequence current, but will respond to positive- and negative-sequence currents of ground faults.

The value in the table is the pickup in percent of the pickup for a three-phase fault with tap C.

TYPE OF FAULT	A		B		C		+ PHASE TAP POSITION + GROUND TAP POSITION
	G	H	G	H	G	H	
A-G	23.4	12.5	23.4	12.5	23.4	12.5	
B-G	27.1	13.5	27	13.5	26.3	13.4	
C-G	27.1	13.5	27	13.5	26.3	13.4	

PRINTED-CIRCUIT CARD

Refer to Figures 5 and 25. The voltage across the primary of the isolation transformer, which is proportional to the voltage at the pilot-wire terminals, is connected to printed-circuit-card pins 1 and 4. IC1A rectifies this voltage and one half of IC3A filters it. The restraint current is connected to pins 1 and 6. It is converted by R43 and R44 to a voltage that IC2A rectifies and one half of IC3A filters. The restraint and operate signals combine at the input of IC4A, along with a bias from P2. The second half of IC4A detects the polarity of the result. The output of IC4 goes to timer IC5.

The pickup-time delay is adjusted by P3 and the dropout-time delay is adjusted by P4. These are preset at the factory. The pickup- and dropout-time delays are both 5 milliseconds for the 60 hertz models, and 6 milliseconds for 50 hertz models. The output of the timer appears at the base of Q3. Q5 and Q4 form a second timer, which inhibits any output for 50 to 100 milliseconds after DC control power is applied. This circuit prevents misoperation during transitory removal of the DC control power. This inhibit time is not part of the pickup time of the relay. After this inhibit time elapses, Q4 receives base drive and Q3 can pass current to Q6, which picks up the output telephone relay.

PICKUP TIME

The pickup-time-versus-multiple-of-pickup is shown in Figure 1. On heavy faults the operating time approaches 16 milliseconds.

DROPOUT TIME

The dropout-time-versus-multiple-of-pickup is shown in Figure 2. The dropout time is always below 25 milliseconds.

PICKUP CURRENT VERSUS PILOT-WIRE LENGTH

The variation of pickup current as a function of pilot-wire length is shown in Figure 3. This characteristic is based on number 19 wire for the pilot-wire pair and on fault-current infeed from one end only. If there is a contribution from more than one end feeding an internal fault, Figure 3 will give an estimate of pickup current that is slightly greater than the actual value.

BURDENS

The burdens given in the following tables are measured with the pilot wire open or shorted, whichever gives the higher value. Burdens at all intermediate current taps are below the burden shown for that phase and ground tap. Burdens are in ohms.

TABLE V(a): 60 HERTZ
THREE-PHASE FAULTS OR LOADS

TAPS	PHASE A				PHASE B				PHASE C			
	R	X	Z	θ	R	X	Z	θ	R	X	Z	θ
AF	0.1	0.0	0.1	0	0.02	0.0	0.02	0	0.06	0.08	0.1	50
AG	0.14	0.0	0.14	0	0.00	0.04	0.04	90	0.04	0.05	0.06	50
AH	0.14	0.0	0.14	0	0.00	0.02	0.02	90	0.04	0.05	0.06	50
BF	0.1	0.0	0.1	0	0.025	0.0	0.025	0	0.06	0.08	0.01	50
BG	0.18	0.0	0.18	0	0.0	0.08	0.08	90	0.10	0.20	0.22	65
BH	0.22	0.0	0.22	0	0.0	0.06	0.06	90	-0.3	0.0	0.3	180
CF	0.1	0.0	0.1	0	0.04	-0.01	0.04	-15	0.07	0.07	0.1	45
CG	0.2	0.0	0.2	0	0.03	0.1	0.01	75	-0.16	0.12	0.2	145
CH	0.26	0.0	0.26	0	0.06	0.15	0.16	70	-0.08	0.00	0.08	180

PHASE-TO-PHASE FAULTS

	PHASE A TO PHASE B				PHASE B TO PHASE C				PHASE C TO PHASE A			
	R	X	Z	θ	R	X	Z	θ	R	X	Z	θ
All Taps	0.15	0.01	0.15	0 to 10	0.1	0.1	0.11	15 to 40	0.18	0.04	0.18	15

PHASE-TO-GROUND FAULTS

TAPS	PHASE A TO GROUND				PHASE B TO GROUND				PHASE C TO GROUND			
	R	X	Z	θ	R	X	Z	θ	R	X	Z	θ
AF	0.1	0.003	0.1	2	0.07	0.03	0.08	20	0.6	0.05	0.6	5
AG	0.5	0.08	0.5	10	0.6	0.16	0.6	15	0.5	0.3	0.6	30
AH	0.23	0.3	0.35	50	0.4	0.4	0.6	45	0.1	0.02	0.1	15
BF	0.1	0.004	0.1	5	0.08	0.02	0.08	15	0.6	0.1	0.6	10
BG	0.6	0.2	0.6	20	0.7	0.2	0.8	20	0.7	0.3	0.7	20
BH	0.5	0.6	0.7	50	0.6	0.8	1.0	50	0.5	0.6	0.7	50
CF	0.1	0.04	0.1	5	0.08	0.01	0.08	10	0.1	0.004	0.1	5
CG	0.7	0.2	0.7	20	0.8	0.3	0.9	20	0.7	0.2	0.7	15
CH	0.8	0.8	1.2	45	1.1	0.9	1.4	40	0.8	0.4	0.9	30

STUDS 13-14:

TAPS	PHASE A TO GROUND			
	R	X	Z	θ
AF, AG, AH	0.5	0.3	0.6	30
BG, BG, BH	0.7	0.4	0.8	30
CF, CG, CH	1.0	0.6	1.1	30

GEK-49794

TABLE V(b): 50 HERTZ
THREE-PHASE FAULTS OR LOADS

TAPS	PHASE A				PHASE B				PHASE C			
	R	X	Z	θ	R	X	Z	θ	R	X	Z	θ
AF	0.089	0	0.089	1 $^{\circ}$	0.026	0.002	0.026	4 $^{\circ}$	0.073	0.087	0.114	50 $^{\circ}$
AG	0.143	0.006	0.143	2.5 $^{\circ}$	0.002	0.044	0.044	87 $^{\circ}$	0.043	0.045	0.062	46 $^{\circ}$
AH	0.142	0.003	0.142	1 $^{\circ}$	0.0008	0.044	0.044	89 $^{\circ}$	0.044	0.045	0.062	45.7 $^{\circ}$
BF	0.093	0.003	0.09	2 $^{\circ}$	0.031	0.004	0.031	6.7 $^{\circ}$	0.080	0.075	0.110	43 $^{\circ}$
BG	0.175	0.023	0.177	7.5 $^{\circ}$	0.003	0.075	0.075	87 $^{\circ}$	0.005	0.101	0.011	115 $^{\circ}$
BH	0.205	0.036	0.208	10 $^{\circ}$	0	0.107	0.107	90 $^{\circ}$	0.007	0.005	0.008	147 $^{\circ}$
CF	0.095	0.005	0.095	3 $^{\circ}$	0.039	0.003	0.039	5 $^{\circ}$	0.079	0.076	0.110	44 $^{\circ}$
CG	0.194	0.045	0.199	13 $^{\circ}$	0.021	0.096	0.099	77.5 $^{\circ}$	0.004	0.101	0.011	112 $^{\circ}$
CH	0.238	0.087	0.253	20 $^{\circ}$	0.289	0.153	0.156	79.3 $^{\circ}$	0.054	0.014	0.056	194 $^{\circ}$

PHASE-TO-PHASE FAULTS

	PHASE A TO PHASE B				PHASE B TO PHASE C				PHASE C TO PHASE A			
	R	X	Z	θ	R	X	Z	θ	R	X	Z	θ
All Taps	0.160	0.015	0.161	5.5 $^{\circ}$	0.074	0.010	0.126	54 $^{\circ}$	0.182	0.038	0.186	12 $^{\circ}$

PHASE-TO-GROUND FAULTS

TAPS	PHASE A TO GROUND				PHASE B TO GROUND				PHASE C TO GROUND			
	R	X	Z	θ	R	X	Z	θ	R	X	Z	θ
AF	0.1036	0	0.1036	0 $^{\circ}$	0.092	0.024	0.095	14.8 $^{\circ}$	0.104	0.032	0.109	17.1 $^{\circ}$
AG	0.522	0.046	0.524	5 $^{\circ}$	0.542	0.115	0.554	12 $^{\circ}$	0.536	0	0.536	0 $^{\circ}$
AH	0.241	0.198	0.312	39.5 $^{\circ}$	0.379	0.316	0.494	40 $^{\circ}$	0.524	0.113	0.536	12.2 $^{\circ}$
BF	0.1034	0	0.1034	0 $^{\circ}$	0.094	0.021	0.096	12.4 $^{\circ}$	0.104	0.031	0.109	16.7 $^{\circ}$
BG	0.564	0.115	0.576	11.5 $^{\circ}$	0.598	0.191	0.628	17.7 $^{\circ}$	0.534	0.150	0.535	1.6 $^{\circ}$
BH	0.419	0.457	0.620	47.5 $^{\circ}$	0.587	0.597	0.838	45.5 $^{\circ}$	0.435	0.217	0.486	26.5 $^{\circ}$
CF	0.104	0	0.104	0.3 $^{\circ}$	0.096	0.016	0.097	9 $^{\circ}$	0.019	0.268	0.112	13.8 $^{\circ}$
CG	0.660	0.165	0.680	14 $^{\circ}$	0.705	0.225	0.74	17.7 $^{\circ}$	0.567	0.039	0.568	40 $^{\circ}$
CH	0.772	0.648	1.008	40 $^{\circ}$	0.996	0.752	1.224	37.9 $^{\circ}$	0.661	0.359	0.752	28.5 $^{\circ}$

STUDS 13-14:

TAPS	PHASE A TO GROUND			
	R	X	Z	θ
AF, AG, AH	0.324	0.166	0.364	27.2 $^{\circ}$
BG, BG, BH	0.474	0.378	0.606	38.6 $^{\circ}$
CF, CG, CH	0.769	0.537	0.938	34.9 $^{\circ}$

GEK-49794

ONE-SECOND RATINGS

Three-phase	250 amperes for 1 second
Phase-to-phase	250 amperes for 1 second
Phase-to-ground	125 amperes for 1 second
Ground circuit studs 13 and 14	125 amperes for 1 second

DC CONTROL BURDEN

48-volt tap at rated voltage

Normal (telephone relay dropped out)	120 milliamperes	6 watts
Operated (telephone relay picked up)	220 milliamperes	11 watts

110-volt tap at rated voltage

Normal (telephone relay dropped out)	85 milliamperes	10 watts
Operated (telephone relay picked up)	180 milliamperes	20 watts

125-volt tap at rated voltage

Normal (telephone relay dropped out)	85 milliamperes	11 watts
Operated (telephone relay picked up)	180 milliamperes	23 watts

CALCULATION OF SETTINGS

There are six settings that can be made on the relay. These are:

- 1) Three-phase pickup amperes - 4, 5, 6, 7, 8, 10 or 12
- 2) Phase-to-phase tap - A, B, or C
- 3) Ground tap - F, G, or H
- 4) Restraint tap - High or low (normally set on high)
- 5) DC control voltage - 48 or 125V
- 48 or 110V
- 6) Target/seal-in unit pickup-current tap - 0.2 or 2.0 amperes.

1. The three-phase pickup should be as sensitive as possible, but in some cases it may be desirable to set the tap setting above full load, so that an open pilot wire in the presence of load will not create an undesirable trip. Select the desired tap on the basis of these considerations. See Figure 35.

2. The phase-to-phase tap should be set on tap C unless the application requires desensitizing the relay for three-phase faults. For these special conditions, Taps A and B are provided.

3. The ground tap provides for ground sensitivity of either 1/4 or 1/8 of the phase tap. Generally the G tap should be used, providing for ground fault sensitivity of 1/4 of the phase tap. This is desirable as it gives substantially less burden on the phase CT's than does the H tap. The F tap is available to make the relay insensitive to zero-sequence current.

With the above selected settings, check the minimum total-fault current (current at all terminals summed) for three-phase faults, for A-to-B phase fault and for a single-line-to-ground fault. Make sure that the relay current required to operate the relay is less than three-fourths (3/4) of the minimum fault current for each of these faults. The current required to operate the relay is defined as:

$$I = \frac{T*N*P*L}{100} \text{ amperes}$$

where I is the current required to operate the relay for the given three-phase tap setting, number of terminals, and pilot-wire characteristics.

T is the three-phase-pickup tap in amperes

N is the number of terminals (2 or 3)

P is the pickup in percent of the three-phase pickup-current tap for the phase and ground taps selected. See Tables III and IV. For example, with a C phase tap and G ground tap, P will be 100 for three-phase faults, 53 for a phase-to-phase B fault, and 263 for a ground fault.

L is a factor based on pilot-wire characteristics. It may be read from the vertical axis of Figure 3.

If more-sensitive protection is required, readjust the phase pickup or ground tap as required, and recheck the pickup.

4. The restraint tap should be set on the high position. The low-restraint tap is available for special applications requiring increased sensitivity. The use of the low-restraint tap may result in lower security.

5. The DC-control-voltage tap should be set to agree with the DC voltage that is supplied to studs 10 and 20 of the relay. The tripping source connected to the contact studs 1, 11, 2, 12 may be a different voltage.

6. The target/seal-in unit should be set on the higher-current tap if the trip current available will always be sufficient to operate the unit. At least 150% of tap current is recommended. If it is necessary to use the lower-current tap, a calculation should be made to make sure that the impedance of the target/seal-in

GEK-49794

unit will not limit the current to a value that will slow or prevent operation of the tripping scheme.

When a ground-sensor current transformer is used connected to studs 13 and 14, the pickup is equivalent to tap H. The ground tap should be set on tap F.

The three-phase-pickup-amperes tap, the phase-to-phase tap, the ground tap and the restraint tap must be set in the same positions in all relays connected to the pilot wire. Auxiliary CT's should be used when the main CT's at the several stations have different ratios.

CONSTRUCTION

The Type-SPD11A relay is assembled in a medium-size, double-end (M2) drawout case having studs at both ends in the rear for external connections. The electrical connections between the relay unit and the case studs are made through stationary molded inner and outer blocks, between which nests a removable connecting plug that completes the circuits. The outer blocks attached to the case have the studs for the external connections, and the inner blocks have the terminals for the internal connections.

Every circuit in the drawout case has an auxiliary brush, as shown in Figure 6, to provide adequate overlap when the connecting plug is withdrawn or inserted. Current circuits are equipped with shorting bars (see internal connections in Figure 5), and on these circuits it is especially important that the auxiliary brush make contact as indicated in Figure 6, with adequate pressure to prevent the opening of the associated CT secondary.

The relay is mounted in a steel framework called the cradle, and is a complete unit with all leads terminated at the inner blocks. This cradle is held firmly in the case with a latch at both top and bottom. The connecting plug, besides making the electrical connections between the respective blocks of the cradle and case, also locks the latch in place. The cover, which is drawn to the case by thumbscrews, holds the connecting plugs in place. The target reset mechanism is a part of the cover assembly.

The relay case is suitable for either semiflush or surface mounting on all panels up to two (2) inches thick, and appropriate hardware will be supplied. Panel thickness must be indicated on the relay order to make sure that proper hardware will be included with the relay. Outline and panel-drilling dimensions are shown in Figure 7.

A separate testing plug can be inserted in place of the connecting plug to test the relay in place on the panel, either from its own source of current and voltage, or from other sources. The relay can be drawn out from the case and replaced by another that has been tested in the laboratory.

The front view of the relay removed from the case is shown in Figure 8. The output isolation transformer is at the bottom, with the input transactor above it. They are located behind the printed-circuit card and nameplate. The four adjustment potentiometers on the printed circuit are located at the left side, and are

accessible from the front when the nameplate is removed. These are factory adjustments and it is not necessary to disturb them unless the relay requires recalibration. Recalibration is described in the **SERVICING** section. Beginning at the top they are: P1 Offset adjust, P2 Pickup adjust, P3 Pickup-time-delay adjust, P4 Dropout-time-delay adjust.

Above the top edge of the nameplate are two tap blocks. On the upper tap block the DC-control-voltage taps are at the left and the three-phase-current taps are at the right. On the lower block the phase taps, A, B and C, are at the left; the restraint taps, HI and LO, are in the middle; and the ground taps, F, G and H, are at the right.

Above the tap blocks, the target/seal-in unit is at the upper left. The tap plate for setting its pickup current is on its right side.

On the right at the top of the relay is the telephone-type output relay.

Figure 9 is a rear view of the relay removed from the case. At the bottom is the lower terminal block with its surge-protection capacitors. On the plate above are three voltage-regulator diodes. Two at the sides regulate DC voltages for the printed-circuit card, while the third limits the maximum pilot-wire voltage. Above the diodes is the phase resistor for the current network. Its two adjustable taps are set at the factory and do not need to be adjusted unless the relay requires recalibration, as described in the **SERVICING** section. Above the plate is the ground resistor for the current network. Its taps are fixed. Insulated wires should be routed so they do not touch either the phase or the ground resistors, as these resistors can become hot during faults. Above the ground resistor is the voltage-limiting saturating transformer with two voltage-dropping resistors for the DC power supply mounted through its center. The resistor values are 800 ohms (right side, rear view) and 1000 ohms (left side, rear view) for 48/125 VDC models, 750 ohms (right) and 800 ohms (left) for 48/110 VDC models. Above the transformer are three smaller resistors: a 50 ohm adjustable resistor on the left, a 150 ohm resistor in the middle, and a 3 ohm on the right. The 50 ohm adjustable resistor is inserted in parallel with the current-measuring resistor on the printed-circuit card by placing the restraint-tap slider in the LO position. As this resistor is adjustable, the restraint can be lowered further by decreasing its value. The 150 ohm resistor is part of the DC supply and the 3 ohm resistor on the right is in the pilot-wire voltage-limiting circuit. The 800 ohm and 1000 ohm resistors (48/125 VDC models) and the 750 ohm and 800 ohm resistors (48/110 VDC models) are in the DC power supply.

Above these three resistors is the upper terminal block with its surge-protection capacitors.

RECEIVING, HANDLING AND STORAGE

These relays, when not included as part of a control panel, will be shipped in cartons designed to protect them against damage. Immediately upon receipt of a relay, examine it for any damage sustained in transit. If injury or damage resulting from rough handling is evident, file a damage claim at once with the transportation company and promptly notify the nearest General Electric Sales Office.

Reasonable care should be exercised in unpacking the relay in order that none of the parts are injured nor the adjustments disturbed.

If the relays are not to be installed immediately, they should be stored in their original cartons in a place that is free from moisture, dust and metallic chips. Foreign matter collected on the outside of the case may find its way inside when the cover is removed, and cause trouble in the operation of the relay.

ACCEPTANCE TESTS

Immediately upon receipt of the relay an inspection and acceptance test should be made to make sure that no damage has been sustained in shipment and that the relay calibrations have not been disturbed.

These tests may be performed as part of the installation or acceptance tests or both, at the discretion of the user.

VISUAL INSPECTION

Check the nameplate stamping to make sure that the model number and rating of the relay agree with the requisition. Remove the relay from its case and check that there are no broken or cracked parts and that all screws are tight.

MECHANICAL INSPECTION

Cradle and Case Blocks

Check that the fingers on the cradle and the case agree with the internal connection diagram. Check that the shorting bars are in the correct position. Check that each finger having a shorting bar makes contact with the shorting bar. Deflect each contact finger to make sure that there is sufficient contact force available. Check that each auxiliary brush is bent high enough to contact the connection plug approximately one-quarter (1/4) inch of plug travel before contacting the main finger.

ELECTRICAL TESTS

The relay is shipped with the taps in the following positions:

Target seal in unit	-	higher-current tap
DC control voltage	-	higher-voltage tap
Current tap	-	minimum-current tap
Phase tap	-	C
Ground tap	-	H
Restraint tap	-	HI

The following tests are designed to verify that the relay has been received from the factory in operating condition. They should be performed even if the final settings for the relay are not available, so that any concealed damage will be detected.

With the taps in the positions listed above, apply rated 125 VDC control voltage to the correct studs as shown on the internal-connections diagram. Apply 2.15 amperes AC to studs 5 and 6. The output relay should operate to close the contacts between studs 1 and 11 and between 2 and 12. Remove the AC and connect two jumpers, one from stud 15 to stud 16 and the other from stud 18 to stud 19. Apply 3.0 amperes to studs 5 and 6. The output relay should remain in the dropped out position.

Target/Seal-in Unit

Manually close and hold the output relay contacts and apply a low value of DC current to studs 1 and 11, increasing it smoothly until the target and seal-in unit picks up. Note the current value. Then decrease the current until the unit drops out and note this current value also. The pickup should be less than or equal to the value given in the **RATINGS** section for the tap being tested, and the dropout should be equal to or greater than the value given.

INSTALLATION PROCEDURE

LOCATION

The relay should be mounted on a vertical surface in a clean and dry location, free from dust or excessive vibration, that is well lighted to facilitate inspection and testing. The outline dimensions and panel-drilling diagram are shown in Figure 7.

GROUNDING

Relay Case Ground

One of the mounting screws or studs should be permanently connected to ground by a conductor not less than number 12 AWG copper wire or its equivalent. This connection is made to ground the case. If the relay is mounted on a conductive panel, the panel should be grounded and the relay case connected to the panel by a short jumper.

Surge Ground

The two surge-ground terminals, 7 and 17, should each be connected to the case of the relay by jumpers to the nearest surface mounting boss on the case. See Figure 10. These jumpers should be as short as possible. If the panel is conductive, place a jumper from each surge ground stud to the nearest possible point on the panel.

When performing AC dielectric tests (Hipot) or DC insulation tests (Megger[®]) it may be necessary to disconnect the surge grounds temporarily. Refer to DIELECTRIC TESTS.

Since most operating companies use different procedures for acceptance and for installation tests, the following section includes several applicable tests that may be performed on these relays.

VISUAL INSPECTION

Repeat the items described under **ACCEPTANCE TESTS - VISUAL INSPECTION**.

MECHANICAL INSPECTION

Repeat the items described under **ACCEPTANCE TESTS - MECHANICAL INSPECTION**.

TELEPHONE RELAY

With the telephone relay in the de-energized position, each circuit-closing contact should have a gap of 0.015 inch (0.38 millimeter). This can be checked in the following manner. First: Check that the armature moves very slightly before its arm touches the first moving contact. This gap should be less than 0.001 inch (0.025 millimeter). If the gap is too large, adjust the armature backstop with a backstop bender. If there is no gap, adjust the backstop. Second: Find the thinnest feeler gage that, when inserted between the armature and pole piece, will prevent the armature arm from touching the first moving contact. Third: Insert between the armature and pole piece a feeler gage 0.007 (0.18 millimeter) thinner than the gage used in the second step, and operate the relay. The contacts should **not** make, as determined by an ohmmeter or test light. The ratio between gaps at the pole piece and at the contacts is two to one. With a feeler gage 0.008 inch (0.20 millimeter) thinner than the gage used in the second step, both contacts **should** make.

Each circuit-closing contact should make 0.005 inch (0.13 millimeter) before the armature arm ends its stroke. This may be checked by inserting an 0.0025 inch (0.065 millimeter) feeler gage between the armature and pole piece and operating the relay by hand. Each contact should make electrically, as determined by an ohmmeter or test light.

Adjustments to telephone relays should be made by properly trained persons using correct tools to preserve the relay operating characteristics.

HIGH-SEISMIC TARGET/SEAL-IN UNIT

NOTE

Since **mechanical adjustment of the target/seal-in unit may affect the Seismic Fragility Level**, it is advised that **no mechanical adjustments be made if seismic capability is a concern**.

The target/seal-in unit has an operating coil tapped for two currents. The relay is shipped with the operating coil in the higher-current position. The tap screw is the one holding the right-hand fixed contact. To change the tap, first remove one screw from the left-hand fixed contact plate and place it in the desired tap position. Next remove the screw from the undesired position and install it in the left-hand fixed contact plate, where the first screw was removed. This procedure allows the tap to be changed without disturbing the mechanical adjustment of the contacts. The relay must **never** be left with screws in **both** tap positions.

MECHANICAL CHECK

Manually operate the target unit by raising the armature until it seats, in contact with the pole piece. The orange target should appear. When the armature is released, the target should remain in view. Push in on the reset arm. The target should drop from view.

Hold up the armature by hand. The target should not be at the end of its travel. Verify this by reaching in one of the windows of the target with a sharp instrument, such as a scribe or knife, and pushing upward. The target should move definitely upward at least 0.015 inch. Remove the sharp instrument. Observe the target while releasing the armature. It should fall visibly downward at least 0.010 inch before being caught by the latch.

Mechanical adjustment of these units requires the correct tools and some experience for best results. The following points should be helpful. With an 0.015 inch shim under the pole piece, both contacts should just make. With current gradually applied, the armature should pick up and seat itself on the pole piece before rated current for that tap is reached. This should occur in a single motion, without two-stepping. When the current is reduced to rated dropout value, the contacts should move to the fully-open position.

ELECTRICAL TESTS - GENERAL

All alternating-current-operated (AC) devices are affected by frequency of the applied signals. Since non-sinusoidal waveforms can be analyzed as a fundamental plus harmonics of the fundamental frequency, it follows that operating characteristics of alternating-current devices (relays) will be affected by a non-sinusoidal applied waveform. Therefore, in order to test alternating-current relays properly, it is essential to use sine-wave currents and voltages.

Similarly, relays requiring DC control power should be tested using well-filtered DC and not unfiltered rectified power. Unless the rectified supply is well filtered, the relay may not operate properly. As a general rule the DC source should not contain more than 5% peak ripple.

DIELECTRIC TESTSIntroduction

The surge capacitors used in this relay do not have voltage ratings to withstand AC high-potential-test voltage; therefore, caution must be exercised when hipotting to avoid damaging these capacitors.

It is recommended that hipot tests be performed on a bench rather than in the panel, and with the relay in a case. If the relay is to be hipotted together with other apparatus in an equipment, all external connections to studs 7 and 17 (surge ground) must be removed.

The hipot test voltage should be 1500 volts AC for new relays or 1125 volts AC for other relays. New relays are defined by ANSI C37.90-1978 as those that have not been in service, that are not more than one year old from date of shipment, and

that have been suitably stored to prevent deterioration. The duration of application of the test voltage should be 60 seconds. Refer to the **RATINGS** section.

Points of Application of Voltage

Common-mode tests (all terminals to case). Remove the surge-ground connections to terminals 7 and 17. Temporary connections should be made to tie all relay terminals, including terminals 7 and 17, together. Hipot voltage can then be applied between this common connection and the case of the relay.

Transverse-mode tests (between circuits). For high-potential tests between circuits of the relay, the internal surge capacitors must be temporarily disconnected from their surge-ground buses inside the relay. Temporary insulation should be installed where needed to isolate surge-capacitor leads from each other and from the bus. The relay-case terminals should be jumpered to make up the groups of studs as shown in Table VI. Hipot voltage may then be applied between any pair of groups.

TABLE VI
CIRCUIT GROUPS FOR TRANSVERSE-MODE HIPOT TESTS

CIRCUIT GROUP	JUMPER BETWEEN TERMINALS NUMBERED
Output Contacts	1, 2, 11 and 12
AC Current	3, 4, 5, 6, 13 and 14
Pilot Wire	8, 9, 15, 16, 18 and 19
DC Control Power	10 and 20

As an alternate to the transverse-mode hipot test, a 500 volt DC insulation resistance test (Megger [®]) can be performed between the circuit groups of Table VI without disconnecting the internal surge capacitors. While this method does not test the relay to its full dielectric rating, it will detect some cases of degraded insulation. The possibility of incorrect reassembly may make this the preferred test method.

Restoring Relay to Service

After the dielectric testing is completed, the surge capacitors should be reconnected to the surge-capacitor buses and all external wiring reconnected, including the wires to studs 7 and 17. The electrical tests in **ACCEPTANCE TESTS - ELECTRICAL** should be performed again.

TESTS TO VERIFY SETTINGS

1. Verify that all settings have been made. These should be in accordance with the section **CALCULATION OF SETTINGS**. The settings are:

- a. Target/seal-in-unit pickup-current tap located on the right-hand side of the unit that is mounted at the upper left of the relay (front view).
- b. DC-control-voltage tap located on the upper tap block on the left side (front view).
- c. Three-phase pickup-amperes tap (current tap) located at the right of the upper tap block.
- d. Phase-to-phase tap located at the left of the lower tap block.
- e. Restraint tap located at the center of the lower tap block.
- f. Ground tap located at the right of the lower tap block.

2. Target/seal-in unit

Close the output telephone relay by hand and apply tap value of DC current to studs 1 and 11. The target should pick up, showing its orange target and closing its contacts. Allow the output telephone relay to drop out. The target should remain picked up. Pick up the output relay again and reduce the DC current to 25% of the tap value. The unit should drop out, opening its contacts, but the target should remain visible. Allow the output relay to drop out. The DC current should go to zero (0). Note the telephone relays have DC-control power across them.

3. DC-control voltage

Check that both screws in the tap block are tightened. Remove the relay nameplate. Apply rated DC-control voltage through a milliammeter to studs 10 and 20. Measure the DC voltage from pin 2 (negative) to pin 1 (positive) of the printed-circuit-card connector (pin 1 is on the left, front view). Read +15 volts \pm 1 volt. Measure the DC voltage from pin 1 (negative) to pin 10 (positive). Read +15 volts \pm 1 volt. Measure the voltage from pin 2 to pin 10. Read +30 volts \pm 2 volts. The DC current drawn by the relay should be within the limits shown in Table VII.

TABLE VII

DC CURRENT

Tap	Applied DC Voltage	DC Current - Milliamperes		
		Minimum	Nominal	Maximum
48	48	105	120	135
110	110	70	85	100
125	125	70	85	100
125	250**	70	85	100

**The 250-VDC rating is accomplished with the use of an external pre-regulator, 0138B7511G-3. The regulator steps the DC voltage from 250 to 125 volts, which is the basic rating of the relay. The regulator is designed to be mounted on the rear

of the SPD relay on the four mounting studs that are normally used to surface-mount the relay. The electrical connections are made as follows:

INPUT 250 VOLTS DC: (+) to terminal "A"
 (-) to terminal "C"

OUTPUT 125 VOLTS DC: (+) from terminal "B" to stud 10 of SPD relay
 (-) from terminal "C" to stud 20 of SPD relay

4. Restraint Tap

For this test it is necessary to connect a 10 µfd capacitor between studs 15 and 16. If the monitor relay (type SPA) is available, the 10 µfd capacitor in it should be used by making the connections between it and the SPD relay. It is not necessary to energize the monitor with AC or DC control power; however, if it is energized it need not be de-energized.

To reduce the test current required, and to avoid the possibility of overheating the network resistors, temporarily move the taps as follows: Current tap-4, Phase tap-C, Ground tap-H, Restraint tap-HI.

The test limits given below are for the HI restraint tap. Since the restraint is continuously adjustable on the LO position, the person specifying the LO restraint tap should also give the test limits.

With the pilot wire disconnected, connect a 0.75 µfd capacitor between relay terminals 18 and 19. In parallel with it, connect a non-inductive resistor of 1400 ohms.

Suddenly apply 30 amperes to studs 4 and 3 to simulate an A-to-ground fault. The relay should operate. Change the resistor to 800 ohms and repeat. The relay should not operate.

Return the taps to their specified positions.

This test verifies the transient operation of the relay for high-current internal and external faults.

5. Current Test, Phase Tap and Ground Tap

Refer to Tables III and IV and calculate the open-pilot-wire pickup of the relay for each type of fault.

Example - Assume the tap settings are 7, B, G

For a phase-A-B fault and with the phase tap on B, the pickup is 90% of tap

$$I_{pu} = I_{tap} \times \frac{90}{100}$$

$$= 7 \times \frac{90}{100}$$

$$I_{pu} = 6.3 \text{ amperes (for A-B fault)}$$

In the same manner, the pickup current for a B-C fault is 4.6 amperes and for a C-A fault is 6.3 amperes.

For a phase-to-ground fault with the relay on tap G, the pickup is given by Table III as 25% of tap.

$$I_{pu} = I_{tap} \times \frac{25}{100}$$

$$I_{pu} = 1.75 \text{ amperes}$$

Apply DC control voltage to the relay. Now apply AC current to studs 4 and 5 for phase A and phase B and check that the relay pickup agrees with the calculated value $\pm 10\%$. On phase C and A the tolerance is also 10%. As the relay is calibrated on phases B and C, the tolerance for this phase pair is 5%. For phase-to-ground faults the tolerance is 10%. The three-phase test need not be performed, but if the tester elects to do so, both the magnitude and angle of each current, and also the phase sequence, must be correct for the test to be valid.

SYSTEM TESTS

Pilot Wire

NOTE: These tests require a test crew at each station.

The characteristics of the pilot wire should be verified at initial installation and periodically thereafter.

The following tests are suggested: Loop resistance, Resistive balance between the two wires, Interwire capacitance, Capacitance to ground of each wire, DC insulating tests between wires and from each wire to ground; for three-terminal lines, Loop resistance to the common point.

WARNING

WHEN TESTING PILOT WIRES, TAKE PRECAUTIONS TO AVOID EXPOSING PERSONNEL TO THE HIGH VOLTAGES THAT MAY APPEAR ON THE PILOT WIRES AT ANY TIME. THE PILOT-WIRE PROTECTIVE SYSTEM PROTECTS EQUIPMENT AGAINST OVERVOLTAGES, BUT IT IS NOT DESIGNED TO LIMIT VOLTAGES TO A LEVEL THAT IS NON-HAZARDOUS TO PERSONNEL. FURTHERMORE, PART OR ALL OF THE PROTECTIVE SYSTEM MAY BE BYPASSED AND BECOME INEFFECTIVE DURING SOME OF THE TESTING.

LEASED PILOT WIRES CAN CHANGE RESISTANCE OR CAPACITANCE ABRUPTLY DUE TO REROUTING BY THE LESSOR.

THE PILOT-WIRE PROTECTIVE SYSTEM SHOULD BE TESTED TO VERIFY THAT IT IS IN WORKING ORDER.

Relay

Check each relay by applying B-C and A-G current with the pilot wire disconnected, to see that it is in working order.

Connect all relays to the pilot wire and disconnect the far relays from their current circuits. Measure and record pickup current for each relay with B-C and A-G current in the near relay. Repeat for each relay. Record these values in a permanent test record.

Current-Transformer Phasing

For the pilot-wire system to work correctly, the phase current supplied to stud 4 (phase A) must be derived from the same primary conductor at all stations. The phases supplied to the other studs must also be the same at each station. The following test procedure is designed to check this by first checking that the phase sequence at the two ends is correct, and then checking that phase A current is in phase at both ends. All taps must be set in the same positions in relays at all stations.

These tests will yield best results when the load is above 50% of tap, balanced, and is steady. It is convenient to run these tests using Type-12XLA12A test plugs, and test plug connection diagrams are shown in Figures 12 through 17. The 12XLA12A test plug is further described in instruction book GEI-25372. The relay's trip circuits should, of course, be open during these tests, as shown in the diagrams.

Test Switch

A test switch and milliammeter are provided with each relay and may be installed for convenience in reading the pilot-wire currents. The test switch has four positions: local (LOC), normal (NOR), circulating (CIR), and remote (REM). In addition, the meter sensitivity in any position may be increased five times (from 25 milliamperes full scale to 5 milliamperes full scale) by pulling the switch handle out. The normal (NOR) position connects the local relay to the pilot wire and removes the meter from the circuit. In the local (LOC) position, the pilot wire is shorted and the local relay is separated from the pilot wire and shorted through the milliammeter. In the circulating (CIR) position the local relay is connected to the pilot wire with the milliammeter in series. The meter reads the current in the pilot wire produced by the combined effect of both the local and remote relays. In the remote (REM) position the local relay is shorted and separated from the pilot wire. The pilot wire is shorted through the milliammeter, which reads the current produced by the remote relay. The meter is coupled to the circuit through a transformer. Therefore the meter is not affected by the DC monitoring current.

The test switch is designed to short both the local relay and the pilot wire when moving between positions, to prevent incorrect tripping. All the test plug drawings, Figures 12 through 17, show the trip circuit open as an added precaution and because tripping of one or both ends is expected in some of the tests. A lamp (not shown in the test plug drawings) may be used to indicate that the relay contacts are closed.

Three-Terminal Lines

Three-terminal installations are tested by taking the stations in pairs, as though there were three two-terminal pilot wires. In doing this the first pair of relays should be checked and current transformer connections changed, if necessary,

before going to the second pair. When checking the second pair, only the current transformer connections at the third station should be changed, if needed. During a test of a pair of relays the third relay should be disconnected from the pilot wire and the pilot-wire terminals open circuited. The breaker at the third terminal must also be opened.

The relay taps at all stations must be at 4, C, H and HI throughout these tests.

First Test - see Figure 12

This test applies normal current to both relays. Neither relay should trip with the meter test switch in the normal (NOR) position. Read and record the relay input current as shown on the test ammeter in the figure. Also read and record the AC pilot-wire currents as indicated by the panel ammeter with the test switch in the local (LOC), remote (REM), normal (NOR) and circulating (CIR) positions. Take readings at both terminals.

Second Test - see Figure 13

This test applies reverse-phase sequence to both relays by interchanging phases B and C. Neither relay should trip with the meter test switch in the normal (NOR) position. The local, remote and circulating pilot-wire currents should be approximately twice the value measured in the first test.

If the local current in this test is one-half, instead of twice, the local current in the first test, then the phase sequence of the currents at the relay is reversed.

Third Test - see Figure 14

This test simulates a single-phase-to-ground, single-end-fed fault on phase A of the local relay. The remote relay receives no current from its current transformers. If the load current is sufficient, both relays should trip. When the meter test switch is placed in the remote (REM) position, both relays should reset and the meter should read zero (0) current. In the local (LOC) position, both relays should reset and the meter should read a current as given by Figure 18.

Fourth Test - see Figure 15

This test simulates a phase-A-to-ground, single-end-fed fault, fed from the remote station. The near relay receives no current from its current transformers. If the load current is sufficient, both relays should trip. When the meter test switch is placed in the local (LOC) position, both relays will reset and the meter will read zero (0). In the remote (REM) position, the meter will read a current lower than that given by Figure 18.

Fifth Test - see Figure 16

This test simulates an external phase-A-to-ground fault. Neither relay should trip.

Sixth Test - see Figure 17

This test simulates a phase-A-to-ground internal fault fed from both stations. The local relay sees phase-A load current as though it were A-to-ground current, while the far relay sees the same current reversed in direction. If the load current is sufficient, both relays should trip.

When the auxiliary ground-current transformer is used, the polarity should be as shown on the external-connection drawing. This should be verified by test.

PERIODIC TESTING AND ROUTINE MAINTENANCE

WARNING: HIGH VOLTAGES MAY APPEAR ON PILOT WIRES UNEXPECTEDLY AT ANY TIME. USE APPROPRIATE CARE WHEN MAKING CONTACT WITH PILOT WIRES OR EQUIPMENT CONNECTED TO THEM.

The pilot-wire protective equipment, if installed, is designed to limit the pilot-wire voltages to a level that will not damage the wires or equipment connected to them. It does not limit the voltages to a level that is safe for unprotected personnel contacting the pilot wires or connected equipment. THEREFORE, USE APPROPRIATE CARE WHEN MAKING CONTACT WITH PILOT WIRES, EVEN WHEN THE PILOT WIRE PROTECTIVE EQUIPMENT IS IN PLACE.

In view of the vital role of protective relays in the operation of a power system, it is important that a periodic test program be followed. It is recognized that the interval between periodic checks will vary depending upon environment, type of relay and the user's experience with periodic testing. Until the user has accumulated enough experience to select the test interval best suited to his individual requirements, it is suggested that the points listed below be checked at an interval of from one to two years.

Check the items described under **ACCEPTANCE TESTS - VISUAL INSPECTION AND MECHANICAL INSPECTION**. Examine each component for signs of overheating, deterioration or other damage. Check that all connections are tight by observing that the lockwashers are fully collapsed.

CONTACTS

Examine the contacts for pits, arc or burn marks, corrosion, and insulating films. For cleaning contacts, a flexible burnishing tool should be used. This consists of a flexible strip of metal with an etched-roughened surface, resembling in effect, a superfine file. The polishing action is so delicate that no scratches are left, yet any corrosion is thoroughly and rapidly cleaned. The flexibility of the tool ensures the cleaning of the actual points of contact. Do not use knives, files, abrasive paper or cloth of any kind to clean relay contacts.

ELECTRICAL TESTS

Measure the pickup of the relay, with the pilot wire open, for phase-A-to-ground and phase-B-to-phase-C current. See Figure 19. Record these values in the test record. It is not necessary to move the taps from the service positions for these tests.

The measured value may be slightly different from that measured at a previous time. This is not necessarily an indication that the relay should be readjusted. The errors of all the test equipment are often additive and the total error of the present setup may be of opposite sign from the error of the previous periodic test. Instead of readjusting the relay, it is recommended that if the apparent error is acceptable, no adjustment be made, and that the error be noted on the relay test record. After sufficient test data has been accumulated, it will become apparent whether the measured errors in the setting are due to random variations in the test conditions or are due to a drift in the characteristics of the relay.

PILOT WIRE

The test switch may be used to verify the integrity of the pilot wire without a test crew at the other station and without opening the trip circuits. In this procedure the line current is used to provide the signals. At the time of installation, measure and record the local, circulating and remote pilot-wire currents and the line current. At any desired later time these four currents may be read again. While the values will in general be different, the ratios between line current and each of the pilot-wire readings should be the same.

In particular, if the ratio of the local pilot-wire current to the line current is the same as at installation, but the ratio of remote pilot-wire current to line current is lower than it was at installation, the pilot wire may be either shorted or open. If the ratio of circulating pilot-wire current to line current is the same as or higher than at installation, a short circuit is indicated; if lower, an open circuit is indicated. When pilot-wire-monitoring relays are not used, this test may be used at regular frequent intervals to perform somewhat the same function manually.

SERVICING

CAUTION

Remove ALL power from the relay before removing or inserting any of the printed-circuit boards. Failure to observe this caution may result in damage to and/or misoperation of the relay.

GENERAL

The factory offers a repair and recalibration service, as do many GE Service Shops. For further information contact your General Electric representative.

Should a printed-circuit card become inoperative, it is recommended that this card be replaced with a spare. In most instances, the user will be anxious to return the equipment to service as soon as possible and the insertion of a spare card represents the most expeditious means of accomplishing this. The faulty card can then be returned to the factory for repair or replacement.

Although it is not generally recommended, it is possible, with the proper equipment and trained personnel, to repair cards in the field. This means that a troubleshooting program must isolate the specific component on the card that has failed. By referring to the internal-connection diagram for the card, it is possible to trace through the card circuit by signal checking, and hence determine which component has failed. This, however, may be time consuming and if the card is

being checked in place in its unit, as is recommended, will extend the outage time of the equipment.

CAUTION:

Great care must be taken in replacing components on the cards. Special soldering equipment suitable for use on the delicate solid-state components must be used and, even then, care must be taken not to cause thermal damage to the components, and not to damage or bridge over the printed-circuit buses. The repaired area must be coated with a suitable high-di-electric plastic coating to prevent possible breakdowns across the printed-circuit buses due to moisture or dust.

ADDITIONAL CAUTION:

Dual in-line integrated circuits are especially difficult to remove and replace without specialized equipment. Furthermore, many of these components are used on printed-circuit cards that have bus runs on both sides. These additional complications require very special soldering equipment and removal tools, as well as additional skills and training, which must be considered before field repairs are attempted.

RECALIBRATION OF MIXING NETWORK

1. Connect a jumper between terminals 15 and 16 and connect a low-voltage AC voltmeter to 18 and 19. Set phase tap at position A and ground tap at position F.
2. Apply 10 amperes rated frequency-balanced three-phase positive-sequence to terminals 4 (ϕA), 5 (ϕB) and 6 (ϕC). Adjust the upper of the two movable taps on the phase resistor until the voltage measured is a minimum. Use caution, as this resistor may be hot.

If there is a significant harmonic content in the applied currents the null will be indistinct and broad. The harmonic-current content can be lowered by using reactance instead of resistance to limit the current. The GE test reactor 6054975G1, a part of the distance-relay test set, may be used. Three reactors are required, one per phase.

Alternatively the null can be observed with a tuned voltmeter that will ignore the harmonic portions of the voltage. An oscilloscope can also be used to judge when the fundamental-frequency component is at a minimum.

3. With the ground tap at position F, and the phase tap at position C, apply three equal currents of 3 amperes, all in phase, to the three terminals, 4, 5 and 6. All currents return through terminal 3. Adjust the lower movable tap of the phase resistor for a minimum reading on the voltmeter.

Verification of Calibration

1. Lift the slider from the current-tap block. Connect an AC voltmeter from the lifted tap to terminal 13.
2. Apply 10 amperes AC to terminals 5 and 6.

3. Measure voltage across the lifted slider and tap listed below. The position of the phase tap will not affect the reading.

TABLE VIII
TRANSACTOR-OUTPUT VOLTAGE VS. TAP

TAP	AC VOLTS	
A	1.45 - 1.65	} Record this measured value
B	2.54 - 2.8	
C	3.7 - 4.1	

If the voltages are outside these limits, the transactor is defective.

4. Apply 10 amperes AC to terminals 14 and 13. Measure the voltage from the lifted slider to the tap listed below.

TABLE IX
VOLTAGE ACROSS GROUND RESISTOR

TAP	AC VOLTS
G	7.2 - 8.4
H	13.7 - 16.0

Calibration of Printed-Circuit Card

1. Apply rated DC to relay and measure DC voltage from printed-circuit-card connector pin 1 to pin 2 (pin 1 positive). The measured voltage should be 15 volts \pm 2 volts. Note: Pin 1 is on the left, front view. Measure the DC voltage from pin 10 to pin 1 (pin 10 positive). The voltage should be 15 volts \pm 2 volts. If these voltages are incorrect, unplug the card and measure the voltages at the connector again. If they are still incorrect, there is a problem in the power supply; if they are correct, there is a problem on the card.
2. Offset adjust P1 (see Figure 25 for location). Connect an oscilloscope to the bottom of D11 with reference connected to pin 1. Set taps for 4, C and H and apply approximately 0.5 ampere AC to terminals 3 and 4. Apply DC and increase the applied AC current until a waveform appears on the screen. Reduce the current until the waveform has rounded peaks without flat tops. The desired waveform has a peak every half cycle (8 milliseconds for 60 hertz, 10 milliseconds for 50 hertz), but in general the waveform that appears will have a peak every full cycle. Adjust P1 and the current alternately until both sets of peaks (at the half and the full cycle) appear and are of equal height.
3. Pickup Adjust P2

With relay taps set at 4, C and H, apply 2.12 amperes AC to studs 5 and 6. Apply DC and adjust P2 until the telephone relay just picks up.

4. Pickup-Delay-Time Adjust

Set a pulse generator to produce 4-volt negative pulses 6 milliseconds long (60 hertz models) or 7 milliseconds long (50 hertz models), repeating every 50 milliseconds. Turn generator off and connect reference to pin 1 and output through a 1000 ohm resistor to top of R29 (D11 and R29 Junction). Connect a dual-channel oscilloscope with reference on pin 1, channel 1 on bottom of D12, and channel 2 on left of R39. Apply rated DC to relay and turn pulse generator on. Using the external pulse-generator control, slowly decrease pulse width from 6 to 4 milliseconds (60 hertz models) or from 7 to 5 milliseconds (50 hertz models).

The channel 2 pulse should disappear as the input pulse width passes through 5 milliseconds (60 hertz models) or 6 milliseconds (50 hertz models). Adjust P3 as needed to make pulses disappear at 5 milliseconds.

5. Dropout-Time-Delay Adjust P4

Using the same setups as in previous step, set pulse width again to 6 milliseconds (60 hertz models) or 7 milliseconds (50 hertz models). Adjust P4 so that the channel 2 pulse stays up for 5 milliseconds (60 hertz models) or 6 milliseconds (50 hertz models) after the channel 1 pulse ends.

6. DC Supervision Time (not adjustable)

Connect a double-pole switch so that one pole applies DC to the relay and the other applies 2 amperes AC to terminals 4 and 3. Set taps on 4, C and H. Connect a dual-channel oscilloscope with reference to pin 1, channel 1 on pin 10 and channel 2 on left of R39. Suddenly close switch and measure time until channel 2 goes up. Time should be 40 to 100 milliseconds.

7. Restraint Check

Connect pin 6 to pin 1 and measure pickup as described above in step 3. Pickup Adjust P2, under Calibration of Printed-Circuit Card. The pickup should be 93% \pm 2% of the pickup in step 3.

RENEWAL PARTS

It is recommended that sufficient quantities of renewal parts be carried in stock to enable the prompt replacement of any that are worn, broken or damaged.

When ordering renewal parts, address the nearest Sales Office of the General Electric Company, specify quantity required, name of the part wanted, and the complete model number of the relay for which the part is required.

An order for a printed-circuit card should include the number on the front of the card.

APPENDIX

PILOT-WIRE PROTECTION

INTRODUCTION

Pilot-wire protection is a complex and active subject. The Institute of Electrical and Electronic Engineers has published a continuing series of papers, guides and standards on the subject. The following four are especially recommended:

IEEE 81-1962 Recommended Guide for Measuring Ground Resistance and Potential Gradients in the Earth.

IEEE 80-1976 Guide for Safety in AC Substation Grounding

IEEE 367-1979 Guide for Determining the Maximum Electric Power Station Ground Potential Rise and Induced Voltage from a Power Fault

A Guide for the Protection of Wire Line Communications Facilities Serving Electric Power Stations. 79-487. Published 1979.

In many cases the communications utility supplying the pilot wire will supply the protective equipment and its engineering. The power system engineer should carefully review the protective system supplied, to see that it meets his objectives as well as those of the communications utility.

As the pilot-wire protection is a part of the relay system, its incorrect installation or maintenance can reduce the relay system's ability to protect the power system. For this reason the pilot-wire protective system should be periodically inspected and tested. When the pilot wire is provided by a communications utility, a joint periodic inspection and test procedure should be agreed upon.

As an example, when isolation or neutralization is used, the shield of the communication cable must not be grounded at any point within the zone of influence (any point subject to ground-potential rise due to the flow of ground-fault current). The cable may be installed correctly, but as it is normal (communications utility) practice to ground the shield whenever it appears, a subsequent inspection and test will often find the shield grounded at some point.

Consideration must be given to the safety of the personnel involved in the testing, as high potential may appear on the pilot wire while the protective equipment is undergoing test.

The SPD relay will withstand voltages up to 600 volts rms on the pilot-wire studs. If the expected maximum common-mode voltage at the pilot-wire terminals produced by ground-potential rise, longitudinal induction, or other causes exceeds this value, then external devices must be used to prevent this voltage from appearing at the relay terminals. Often the pilot wire itself cannot withstand the voltage and also requires protection. Protection may also be required due to hazards to personnel.

Mutual-Drainage Reactors

Mutual-drainage reactors are primarily used for protection against longitudinal induction. For the reasons described below their usage is generally limited to installations where the maximum induced voltage is less than 1500 volts rms.

Neutralizing Reactors

Neutralizing reactors are recommended where station ground can differ from remote ground by more than 600 volts rms during power-system ground faults.

Mutual-drainage reactors and neutralizing reactors may be used together or separately as required.

MUTUAL-DRAINAGE REACTOR (see Figure 20)

Mutual-drainage reactors cause a current to flow over the pilot-wire conductors to produce a voltage drop that will lower the voltage at the relay to an acceptable level. Mutual-drainage reactors are available to connect the wires to local ground without shorting out the desired pilot-wire signal. Gas tubes are used with the mutual-drainage reactors to prevent drainage current from flowing continuously and also so the monitoring relays are not shorted out. The current in the pilot wire should be compared with the short-time rating of the wire to make sure that it will not be damaged. The mutual reactor forces equal current flow through each wire. If the wire resistances are not perfectly balanced, some of the longitudinal voltage will be converted to transverse voltage, which can cause the SPD relay to misoperate. A careful analysis of all sources of unbalance must be made to ensure that the maximum transverse voltage produced will not affect the relay. Mutual-drainage reactors must be installed at more than one location to allow current to flow.

Mutual-drainage reactors are not intended for protection against ground-potential rise. To avoid the effects of ground-potential rise, the mutual-drainage reactor gas-tube ground terminal should always be connected to a remote ground point outside the zone of influence.

NEUTRALIZING REACTOR (see Figure 21)

The neutralizing reactor (often called a transformer) inserts a high impedance in series with the common-mode voltage by means of a two-winding reactor. The relay voltage is differential mode and passes through the reactor largely unaffected. A small amount of common-mode current is required to excite the reactor, and is provided by exciting capacitors on the station side of the reactor. Everything connected to the pilot wires on the line side of the reactor is at high potential during a disturbance, and must be carefully insulated from local ground.

The impedance to ground from the pilot-wire side of the neutralizing reactor consists of a network that includes 1) the distributed pilot-wire series resistance, 2) the distributed shunt capacitance from the pilot wires to ground, and 3) the neutralizing reactor(s) and exciting package(s) (if any) at the other terminal(s). It should be determined whether or not this impedance is low enough to allow ample current flow during a ground-potential rise; ample current being the current needed to excite the core of the neutralizing reactor without causing excessive voltage

rise on the pilot wire. If the impedance is not low enough, additional capacitors may be added to bring the total capacitance of each pilot-wire-to-ground above 1 microfarad. A 1 microfarad external capacitor is available (see Figure 28). External capacitors must be grounded to remote ground and are best connected at the midpoint of the pilot wire. If it is decided that protection against ground-potential rise is not needed at all terminals, a neutralizing reactor need be installed only where protection is needed.

The voltage rating of the neutralizing reactor must be high enough so that it will not saturate. If it saturates, its voltage-blocking ability will be reduced and the voltage at the relay terminals may rise to excessive levels.

The common-mode voltage may have DC offset. This is common when the voltage is produced by ground-potential rise due to a local ground fault. The neutralizing reactor must have sufficient voltage rating so that it will not saturate under the worst conditions of DC offset and residual flux in its core. A gas tube should be connected across the line terminals of the reactor to protect against excessive voltage if one of the pilot wires shorts to ground. The gas tube's ground terminal must not be grounded in this application.

CONDUCTOR SHIELDING

A shield will protect against electrostatic coupling in a zone if it is grounded at least at one point. To avoid coupling ground-potential rise to the conductors, the shield should be grounded at a point with negligible ground-potential rise.

A shield will protect against magnetic coupling in a zone if it is grounded at both ends of the zone so that current can flow through the shield. Shielding can be used to good advantage when the pilot wires are parallel to power conductors, to minimize effects of longitudinal induction. However, if the shield is continued to the power station and grounded to the ground mat, it will be subjected to heavy currents caused by ground-potential rise during ground faults. The shield can be sized to withstand these currents or it can be ended and grounded outside the zone of influence of ground-potential rise. In this case the section from the last ground point into the station must be insulated for the ground-potential-rise voltage. The shield beyond the last ground point provides no shielding against magnetic induction. Decreasing shield resistance will produce a less-than-proportional increase in shield current due to inductance. All shield sections, even an insulated one entering a station, should be grounded at some point to provide electrostatic shielding. It is usually best to ground at a location with minimum ground-potential rise.

G E Company offers a mutual-drainage reactor, a neutralizing reactor, and a gas tube that are suitable for many applications. Their characteristics are listed in tables X, XI and XII. Their outlines and mounting information are shown in Figures 22 and 27.

TABLE X

Mutual-Drainage Reactor - Order as 0257A9787G4 (60 hertz) or G9 (50 hertz)

DC-Winding Resistance	8.0 Ohms
each winding	
Leakage Inductance at rated frequency	0.004 H
One-Second Rating	90 Amperes AC
each winding	
Saturation Voltage	500 Volts
each winding at rated frequency	
Exciting Impedance	24,000 to 48,000 Ohms
windings in series at 120 volts, rated frequency	
High-Potential Test	4,000 volts AC
rated frequency between windings and each winding to frame	
Supplied with a Gas Protector Tube	
Weight Approximate	
(60 Hz Model)	40 Pounds (20 Kilograms)
(50 Hz Model)	48 Pounds (22 Kilograms)

TABLE XINeutralizing Reactor - Order as 0257A9787G3 (60 Hz) or G8 (50 Hz)

DC-Winding Resistance	88 Ohms
each winding	
Leakage Inductance at rated frequency	0.172 H
each winding	
Total Impedance at rated frequency	220 Ohms
both windings in series opposing	
Voltage Rating	500 Volts DC or Peak AC
Maximum Voltage Across Windings	4,000 Volts AC
windings in parallel, rated frequency	
Exciting Current	0.015 to 0.030 Amperes AC
4,000 volts rated frequency, windings in parallel	
One-Second Rating	10 Amperes AC
Continuous-Current Rating	0.5 Ampere AC
High-Potential Test	10,000 volts AC
windings to frame for 1 minute	
Induced-Voltage Test	10,000 volts AC
windings in parallel for 1 minute	
Supplied with a Gas Protector Tube	
Weight Approximate	
(60 Hz Model)	80 Pounds (36 Kilograms)
(50 Hz Model)	96 Pounds (44 Kilograms)

TABLE XII

Gas Protector Tube (Supplied with neutralizing transformer and mutual-drainage reactor) Available separately - order 0257A9787 G005

AC rms Breakdown Voltage	300-500 Volts
One-Second Current Rating	90 Amperes
Two-Second Current Rating	40 Amperes

Since the last edition, the CAUTION has been added at the beginning of the SERVICING section.

LIST OF ILLUSTRATIONS

<u>Figure</u>	<u>Page</u>
1 Typical Pickup Time Versus Multiple of Pickup	39
2 Typical Dropout Time Versus Multiple of Pickup	39
3 Typical Pickup Versus Pilot Wire Length	40
4 Cradle Block and Terminal Block Cross Section	40
5 Printed-Circuit Card Internal Connections Diagram	41
6A Internal Connections Diagram for the Type SPD11A Relay	42
6B Internal Connections Diagram for the Type SPD11A Rev.A Relay	43
7 Outline Drawing and Panel-Drilling Dimensions	44
8 Front View of Type SPD11A Relay	45
9 Rear View of Type SPD11A Relay	46
10 Method of Connecting Surge Ground to Case	47
11A Elementary Diagram of Internal Connections	48
11B Elementary Diagram of Internal Connections	49
12 Test Connections Diagram for Test 1	50
13 Test Connections Diagram for Test 2	50
14 Test Connections Diagram for Test 3	51
15 Test Connections Diagram for Test 4	51
16 Test Connections Diagram for Test 5	52
17 Test Connections Diagram for Test 6	52
18 Pilot-Wire-Short-Circuit Current Versus Input Current	53
19 Field Test Connections for Periodic Testing	54
20 External Connections Diagram for Mutual-Drainage Reactor	55
21 External Connections Diagram for Neutralizing Reactor	55
22A Outline and Mounting Dimensions for 60 Hertz Neutralizing Reactor	56
22B Outline and Mounting Dimensions for 50 Hertz Neutralizing Reactor	56
23 Simplified External Connection Diagram Showing Relay Polarities	57
24 Printed-Circuit Card	57
25 Functional Block Diagram	58
26 Connections of External Pilot-Wire Protection Equipment	59
27A Outline and Mounting Dimensions for 60 Hertz Mutual-Drainage Reactor	60
27B Outline and Mounting Dimensions for 50 Hertz Mutual-Drainage Reactor	61
28 Outline and Mounting Dimensions for External Exciting Capacitor	62
29 Outline, Panel-Drilling Dimensions and Electrical Connections Diagram for External AC Milliammeter Auxiliary Transformer	63
30 Outline, Panel-Drilling Dimensions and Electrical Connections Diagram for External AC Milliammeter Switch	64
31 Outline, Panel-Drilling Dimensions and Electrical Connections Diagram for External Neutralizing Transformer Exciting Package	65
32 Outline and Panel-Drilling Dimensions for External AC Milliammeters	66
33A Typical Elementary Diagram of External Connections	67
33B Typical Elementary Diagram of External Connections	68
34A Typical Elementary Diagram of External Connections for Three-terminal Lines	69
34B Typical Elementary Diagram of External Connections for Three-terminal Lines	70
35 Pickup Versus Pilot-Wire Length with Far End of Pilot Wire Open	71

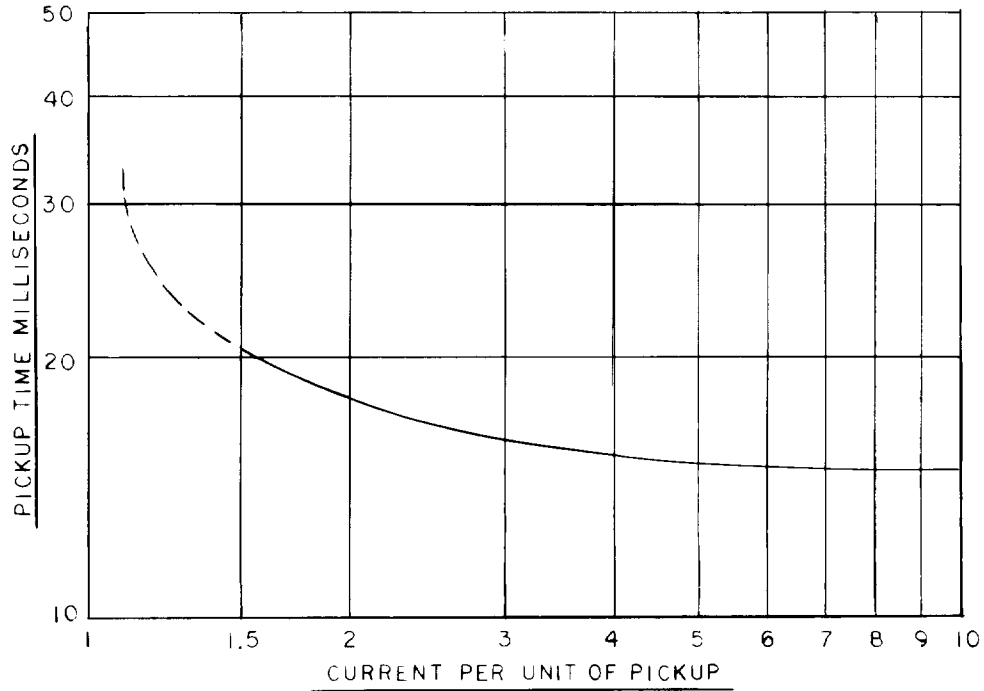

Figure 1 (0275A2036-1) Typical Pickup Time Versus Multiple of Pickup

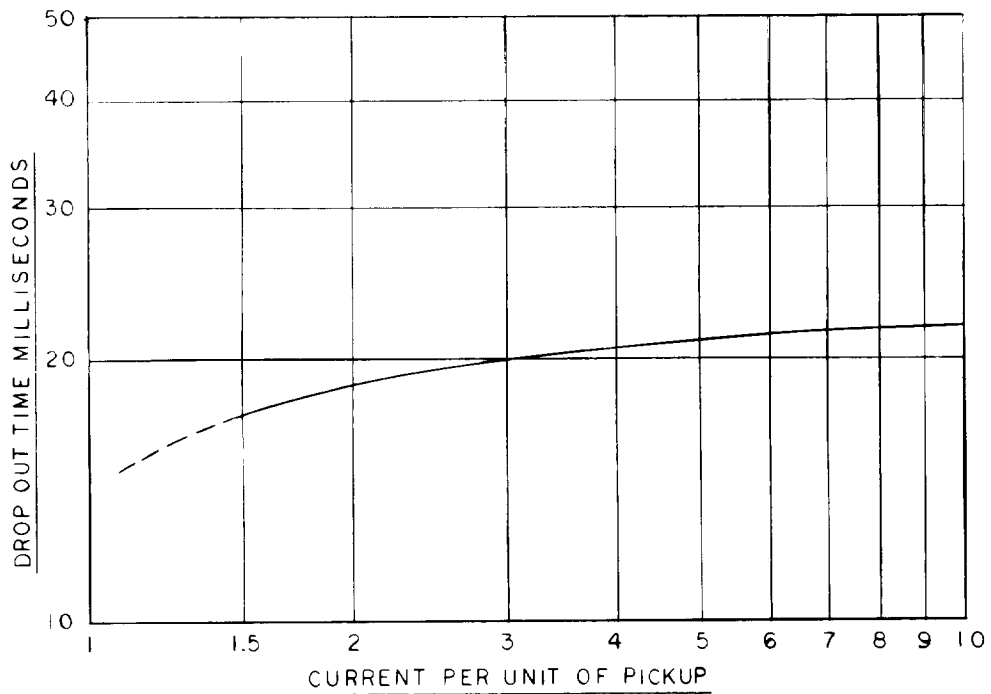

Figure 2 (0275A2037-1) Typical Dropout Time Versus Multiple of Pickup

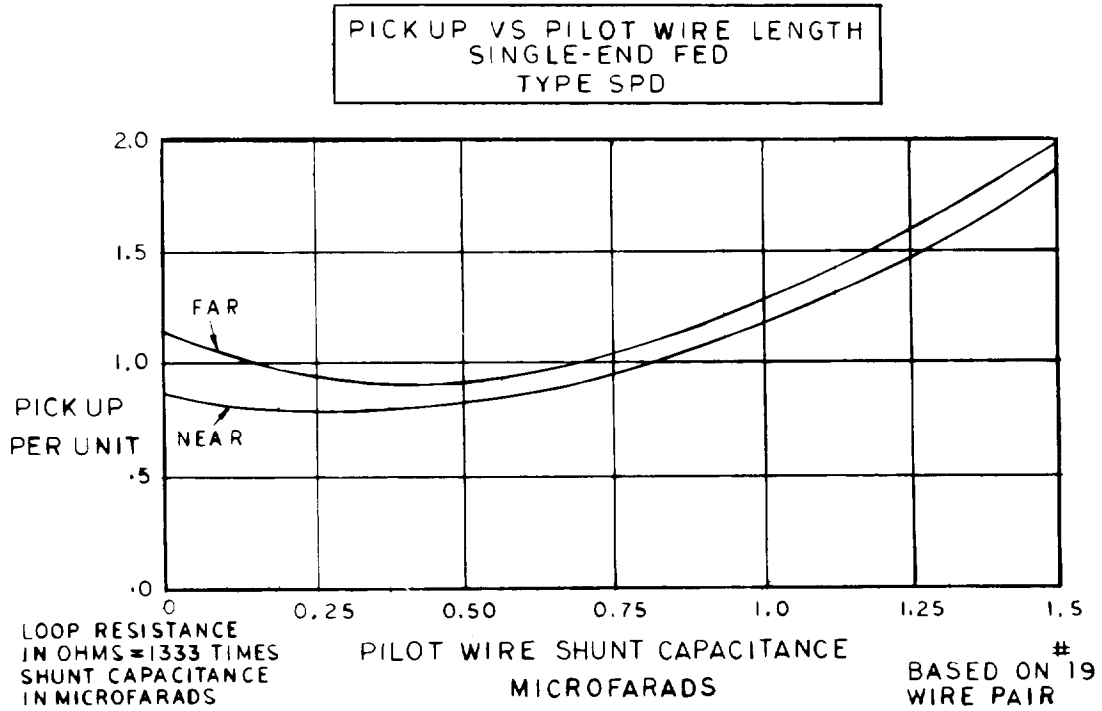
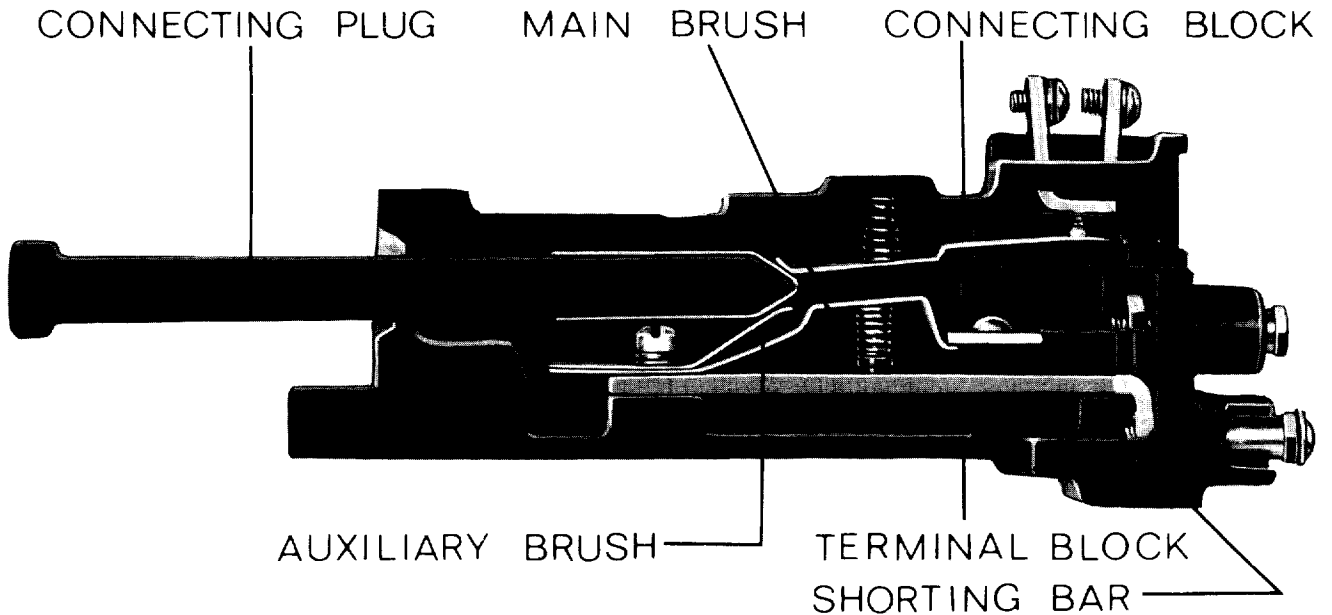

Figure 3 (0273A9054-3) Typical Pickup Versus Pilot Wire Length



NOTE: AFTER ENGAGING AUXILIARY BRUSH CONNECTING PLUG TRAVELS $\frac{1}{4}$ INCH BEFORE ENGAGING THE MAIN BRUSH ON THE TERMINAL BLOCK

Figure 4 (8025039) Cradle Block and Terminal Block Cross Section

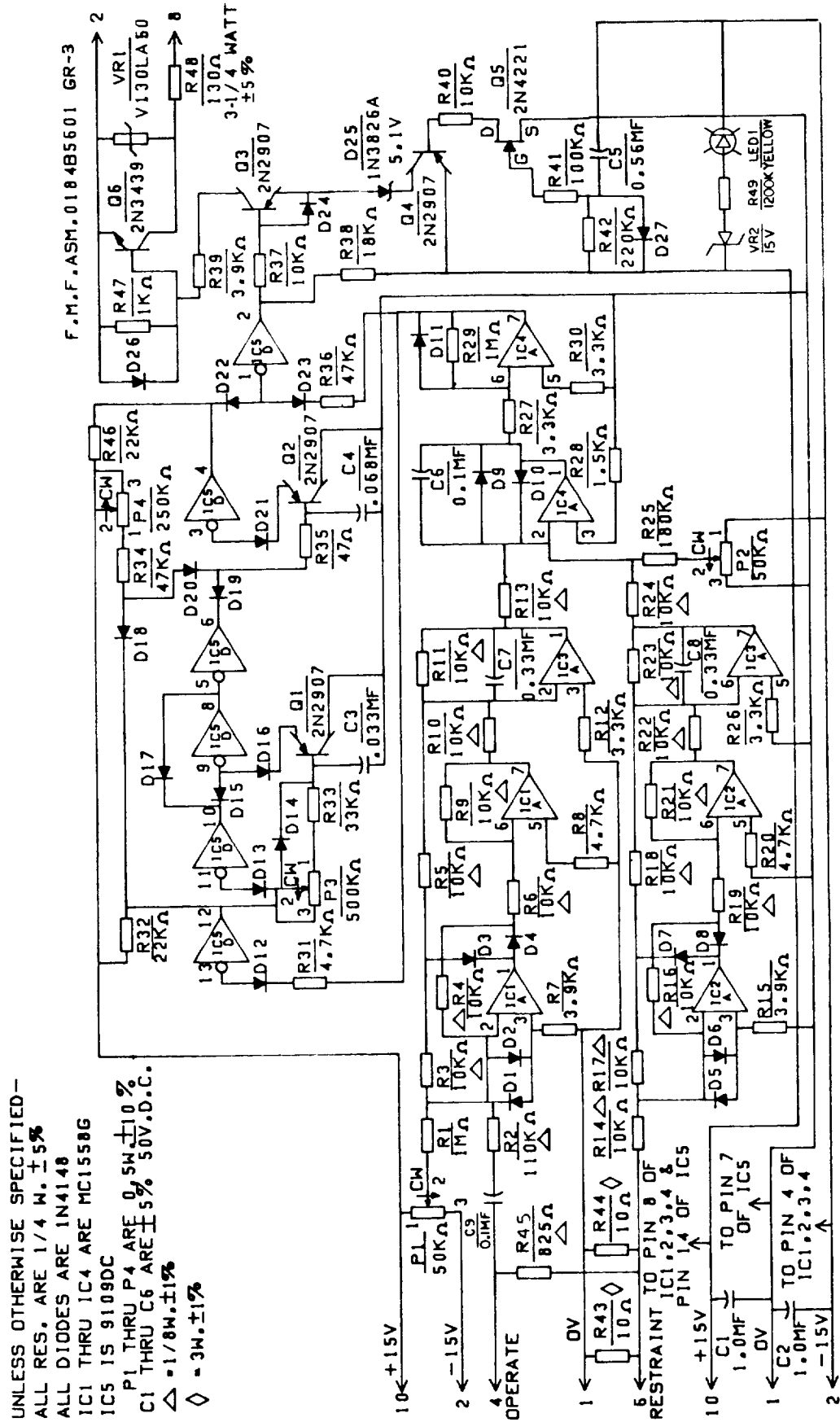

Figure 5 (0184B5701, Sh. 3 1) Printed-Circuit Card Internal Connections Diagram

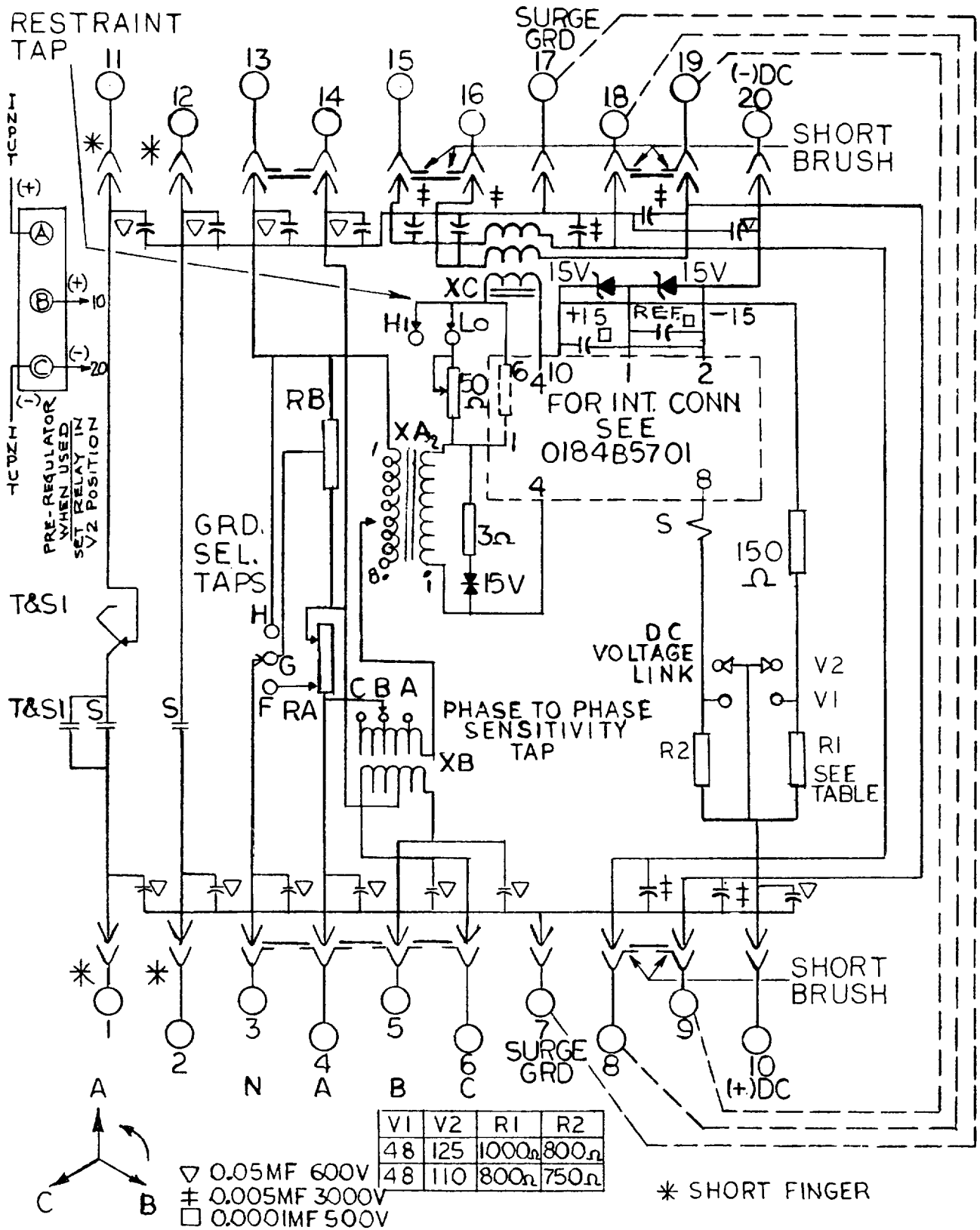

Figure 6B (0285A9904) Internal Connections Diagram for the Type SPD11A Relay, Revision A

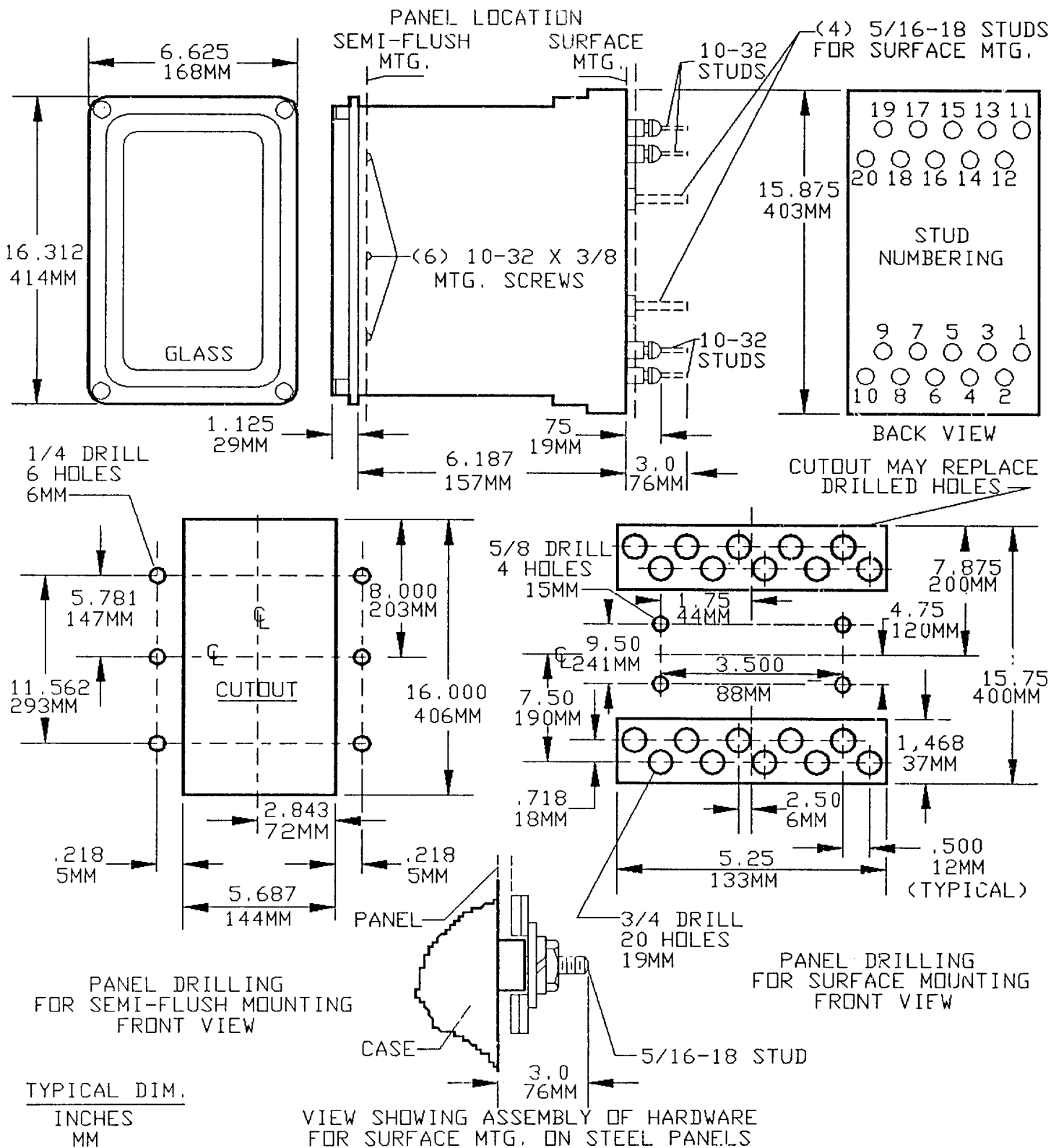

Figure 7 (K-6209274 [6]) Outline Drawing and Panel-Drilling Dimensions for the Size M2 Case Used for Type SPD Relays

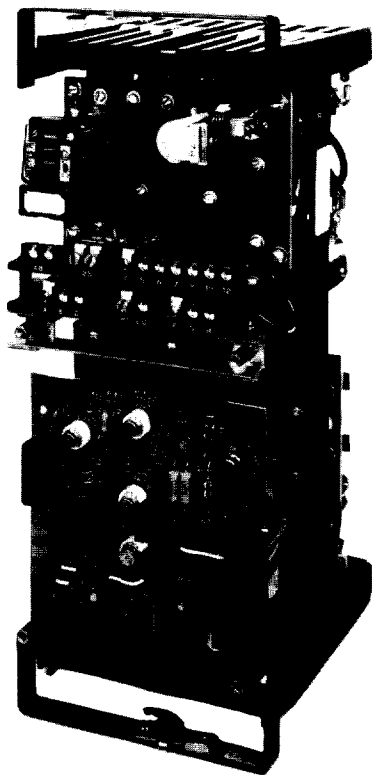
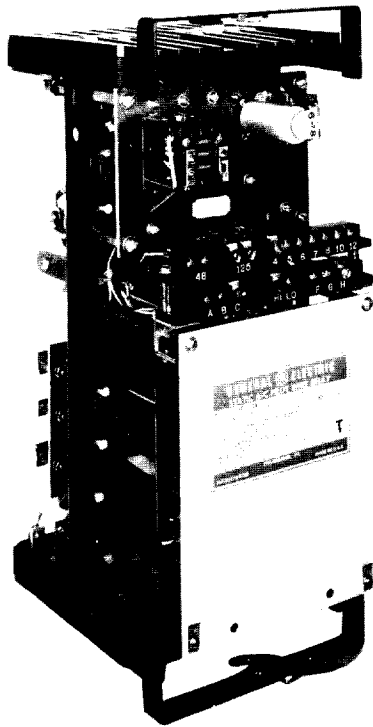

Figure 8 (8043289 and 8043333) Front View of Type SPD11A Relay

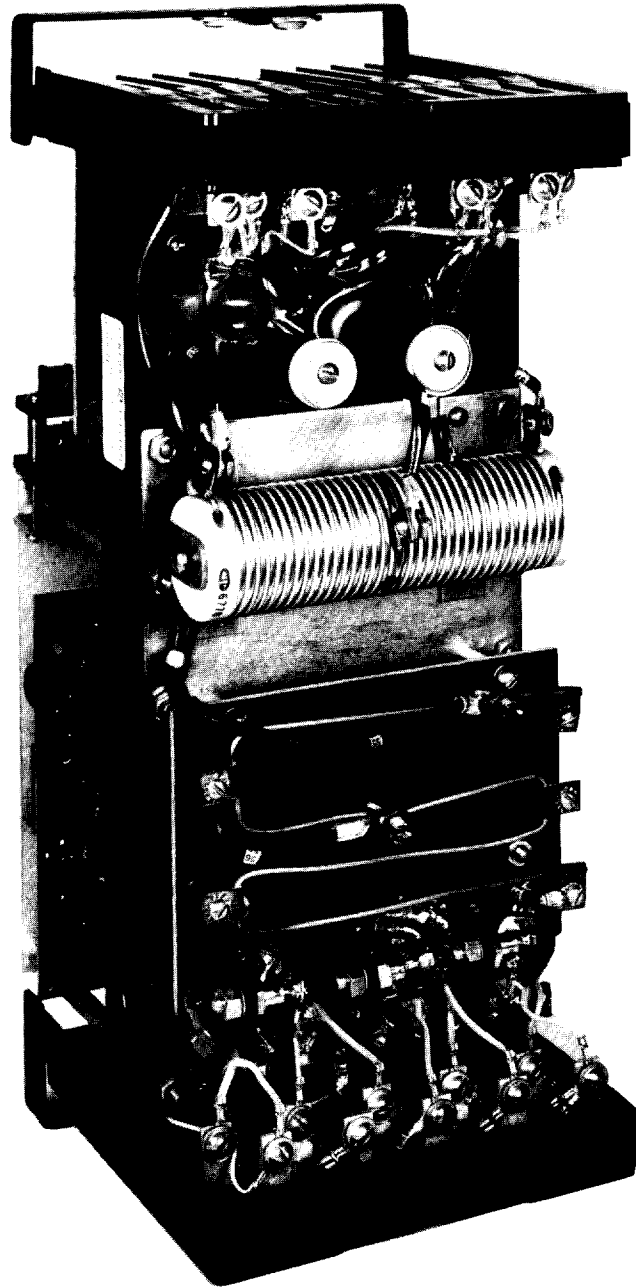

Figure 9 (8043290) Rear View of Type SPD11A Relay

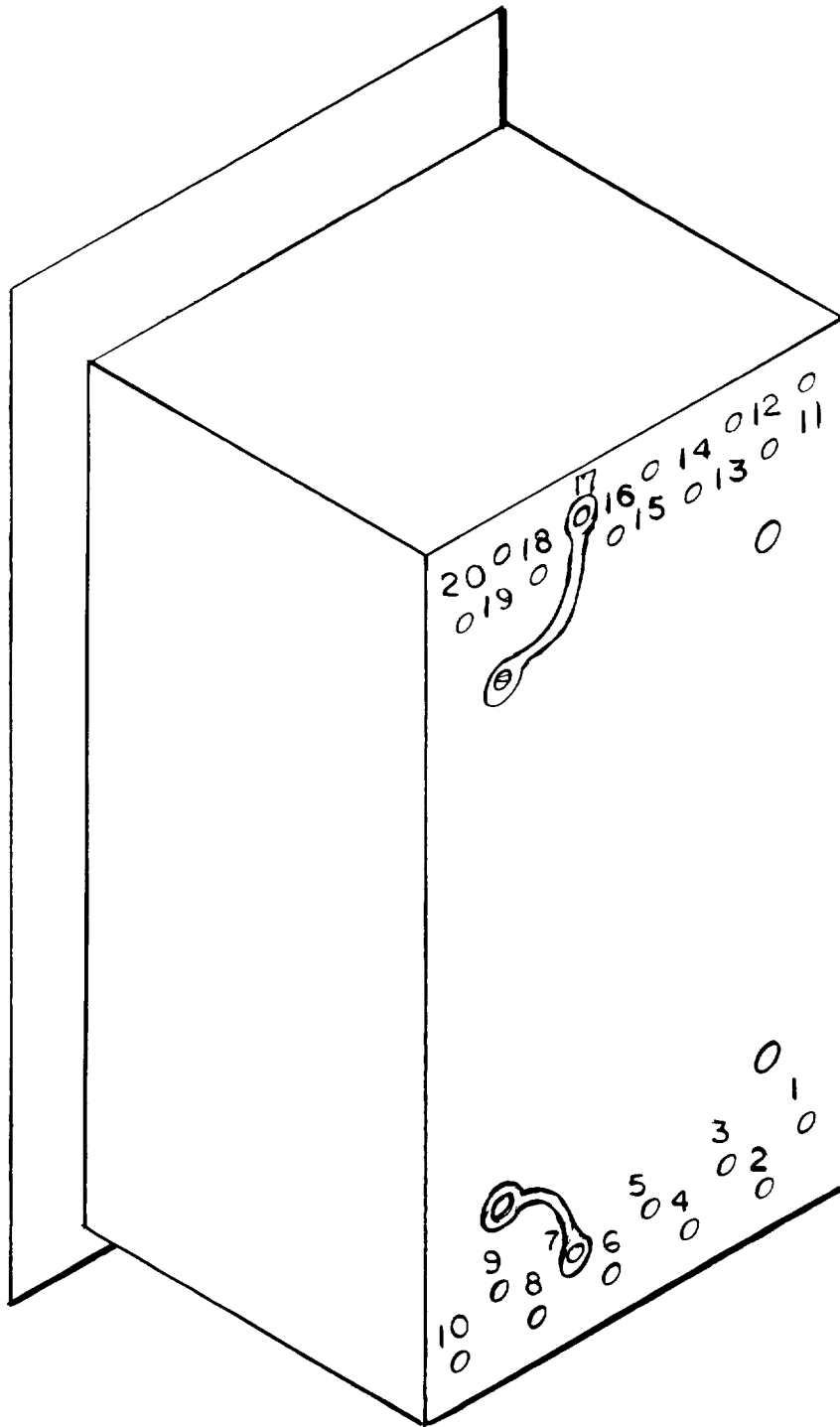

Figure 10 (0273A9053) Method of Connecting Surge Ground to Case

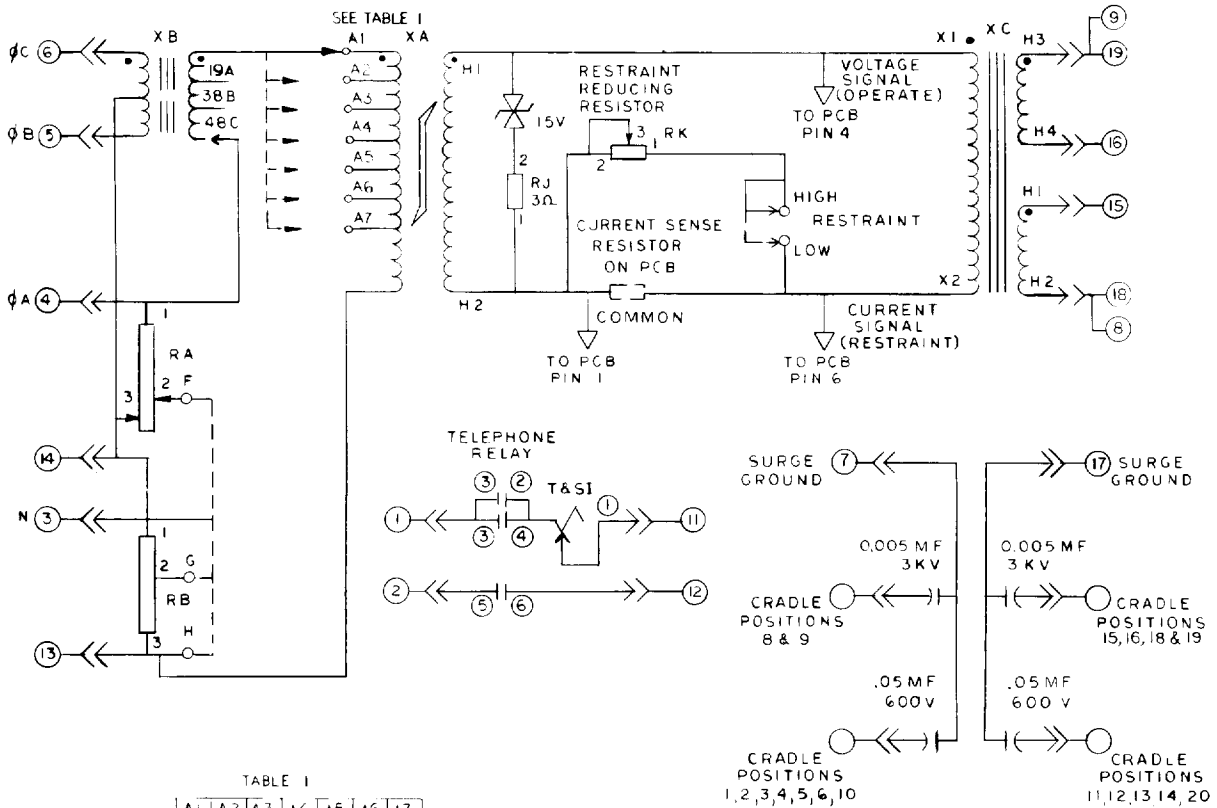

TABLE I

	A1	A2	A3	A4	A5	A6	A7
1 AMP MODELS	0.8	1.0	1.2	1.4	1.6	2.0	2.4
5 AMP MODELS	4	5	6	7	8	10	12

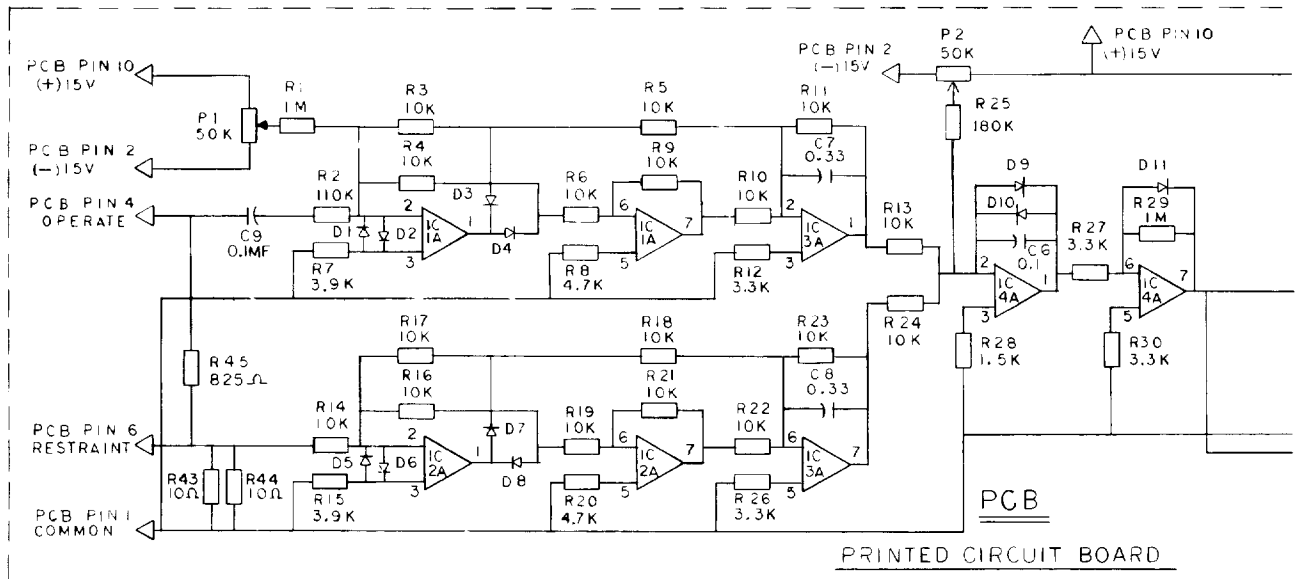

Figure 11A (0136D1473-7) Elementary Diagram of Internal Connections

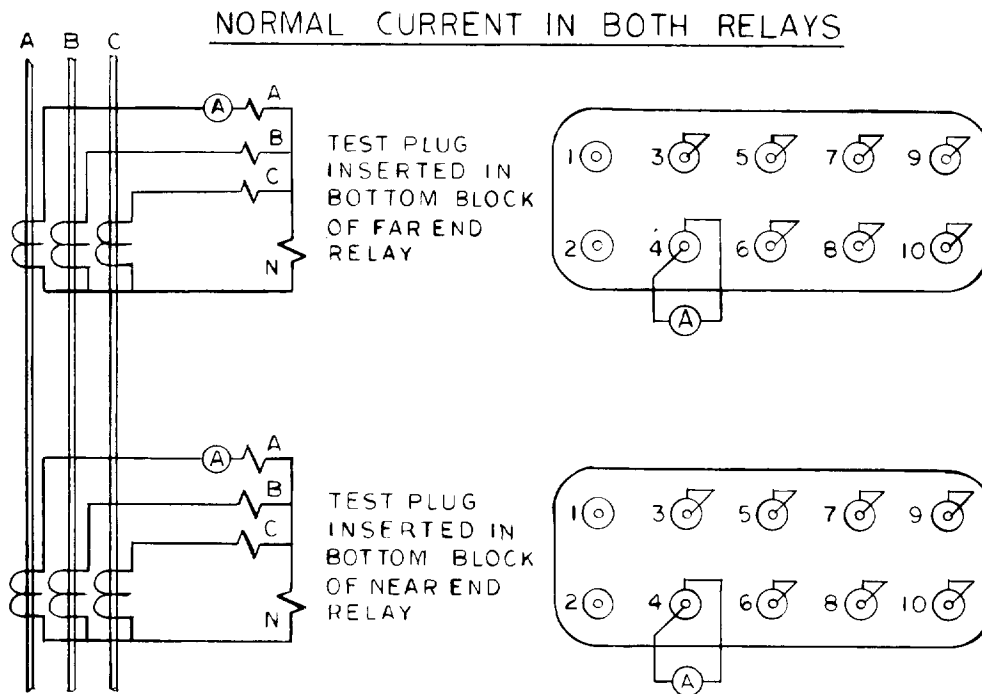

Figure 12 (0275A2016) Test Connections Diagram for Test 1

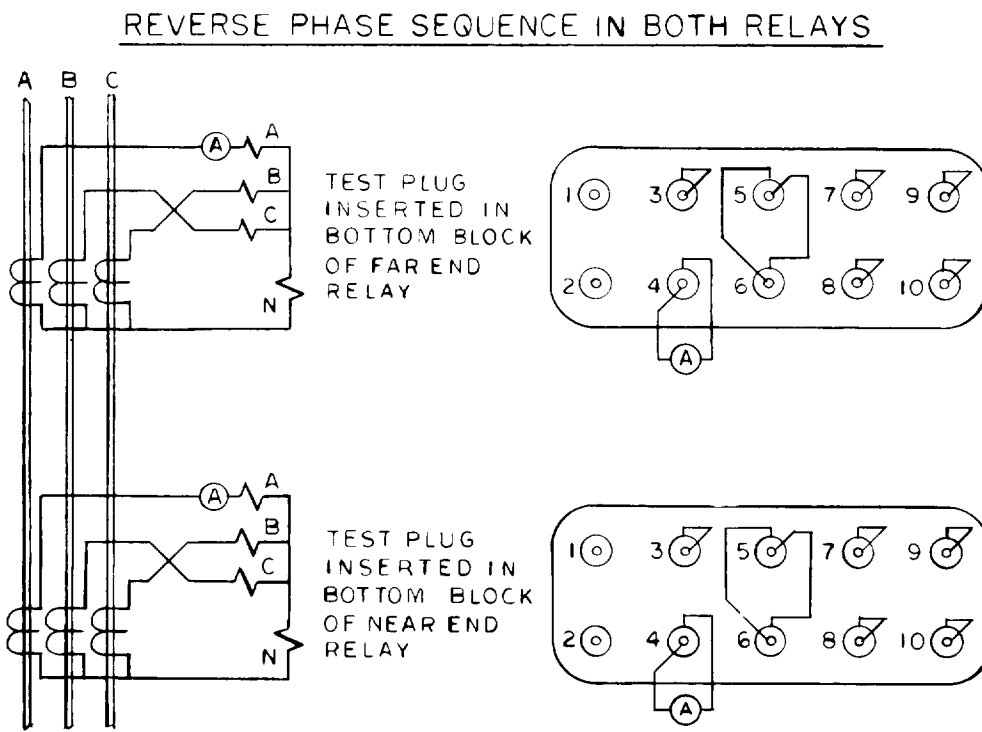

Figure 13 (0275A2017) Test Connections Diagram for Test 2

SIMULATION OF PHASE A TO GROUND FAULT AT NEAR END WITH FAR END BREAKER OPEN

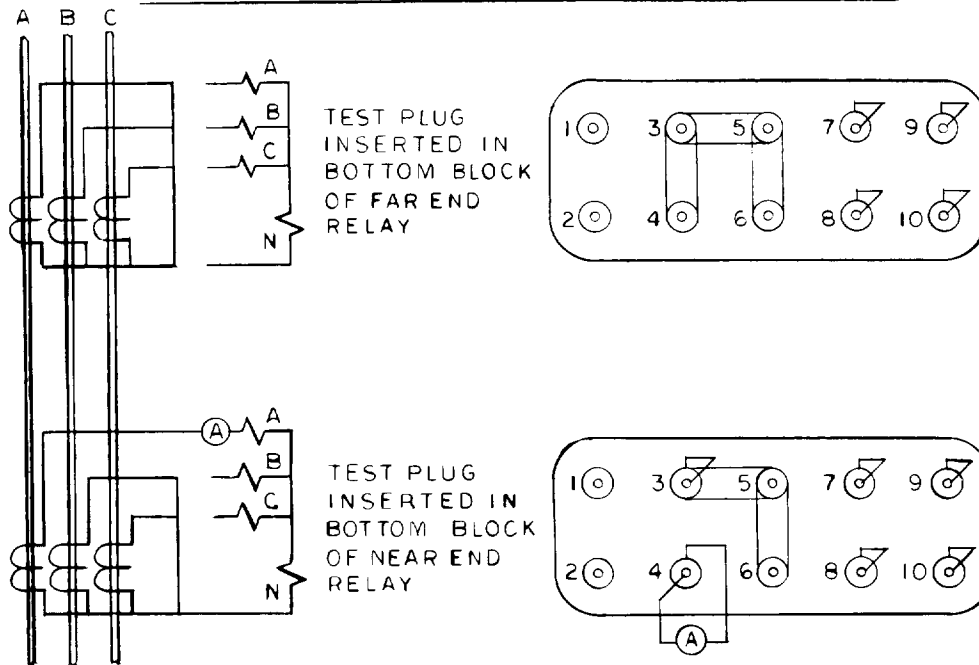

Figure 14 (0275A2018) Test Connections Diagram for Test 3

SIMULATION OF PHASE A TO GROUND FAULT AT FAR END WITH NEAR END BREAKER OPEN

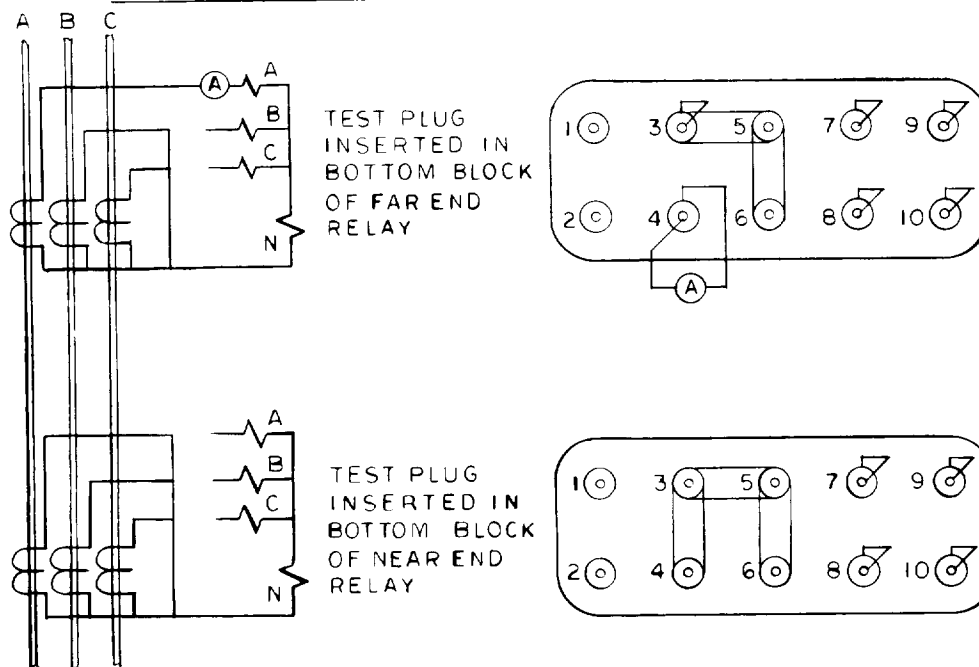

Figure 15 (0275A2019) Test Connections Diagram for Test 4

SIMULATION OF PHASE A TO GROUND EXTERNAL FAULT

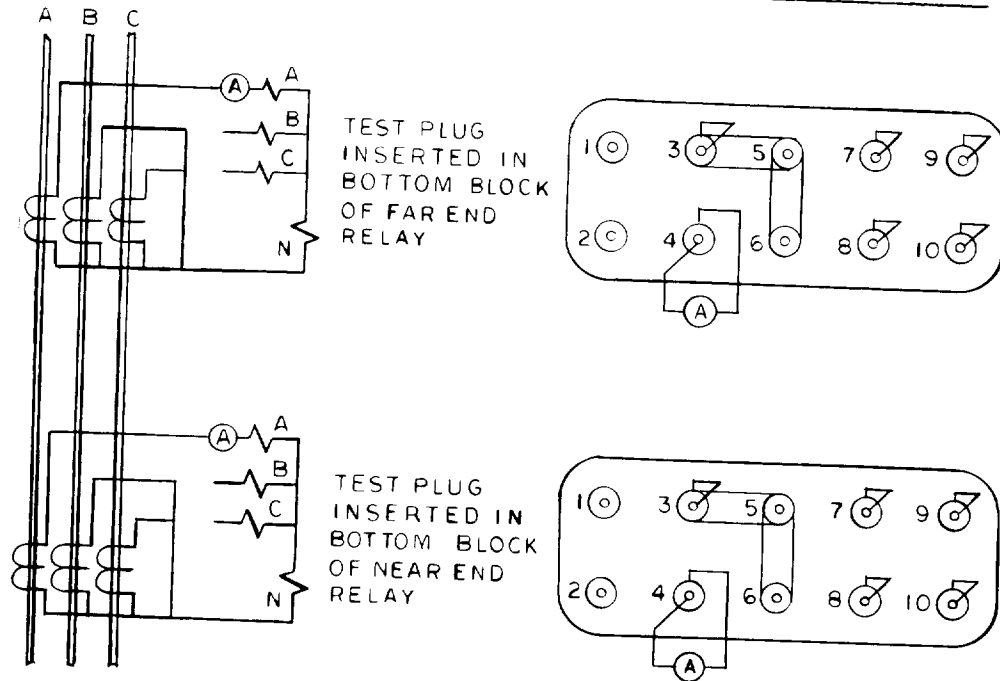

Figure 16 (0275A2020) Test Connections Diagram for Test 5

SIMULATION OF PHASE A TO GROUND INTERNAL FAULT

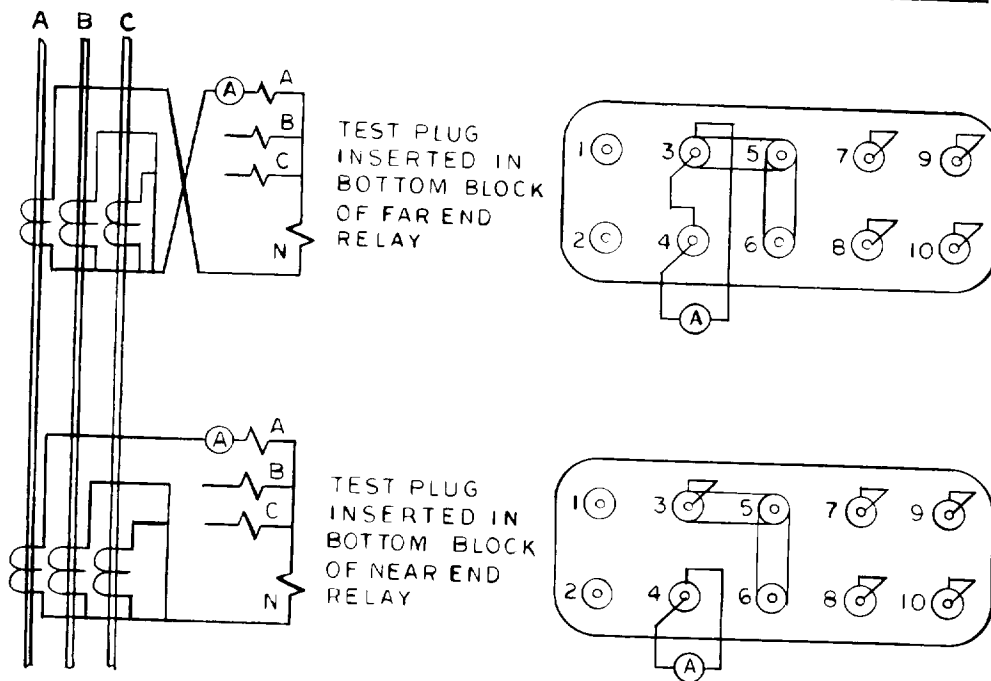

Figure 17 (0275A2021) Test Connections Diagram for Test 6

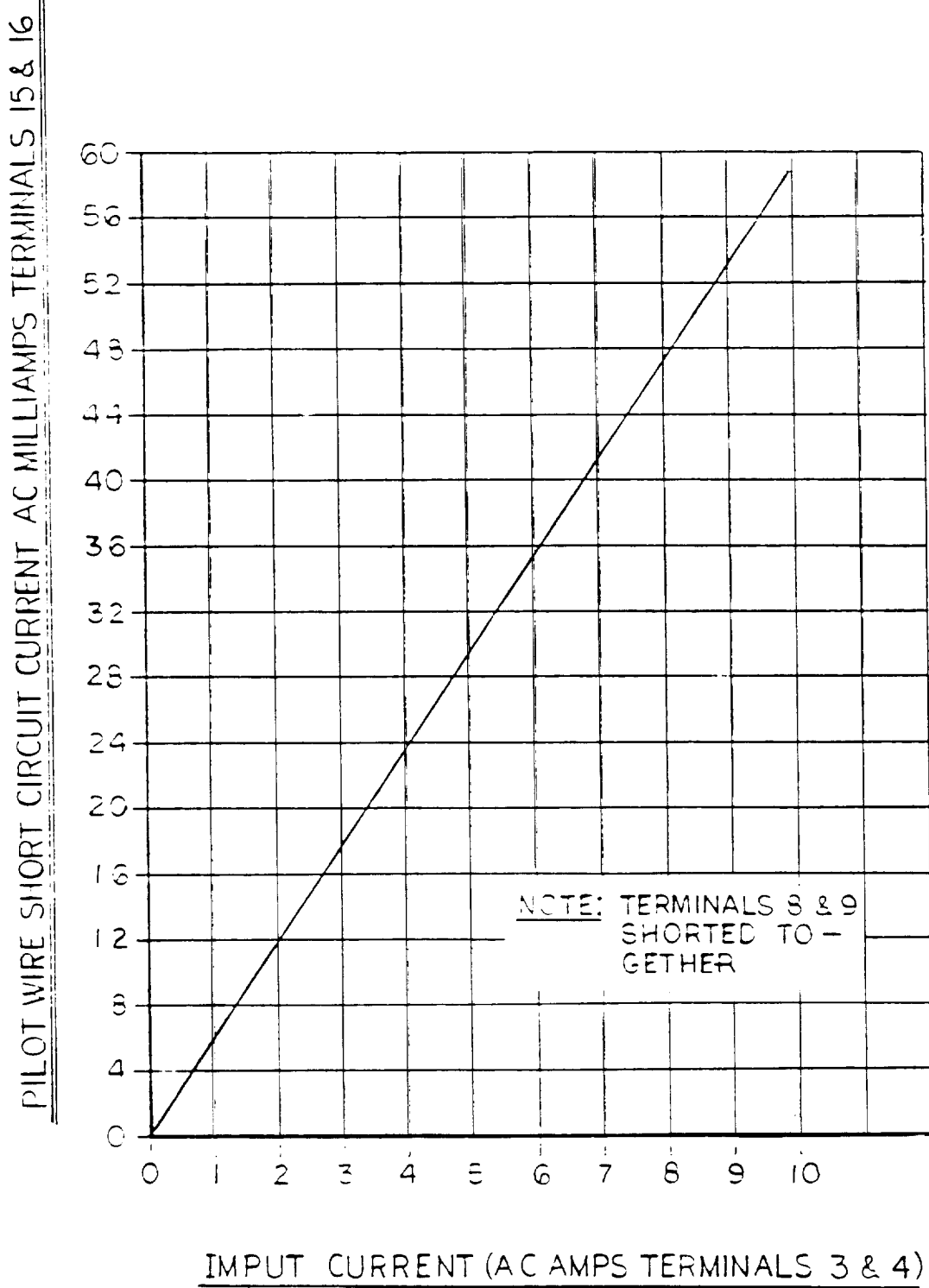

Figure 18 (0275A2038-1) Pilot-Wire-Short-Circuit Current Versus Input Current

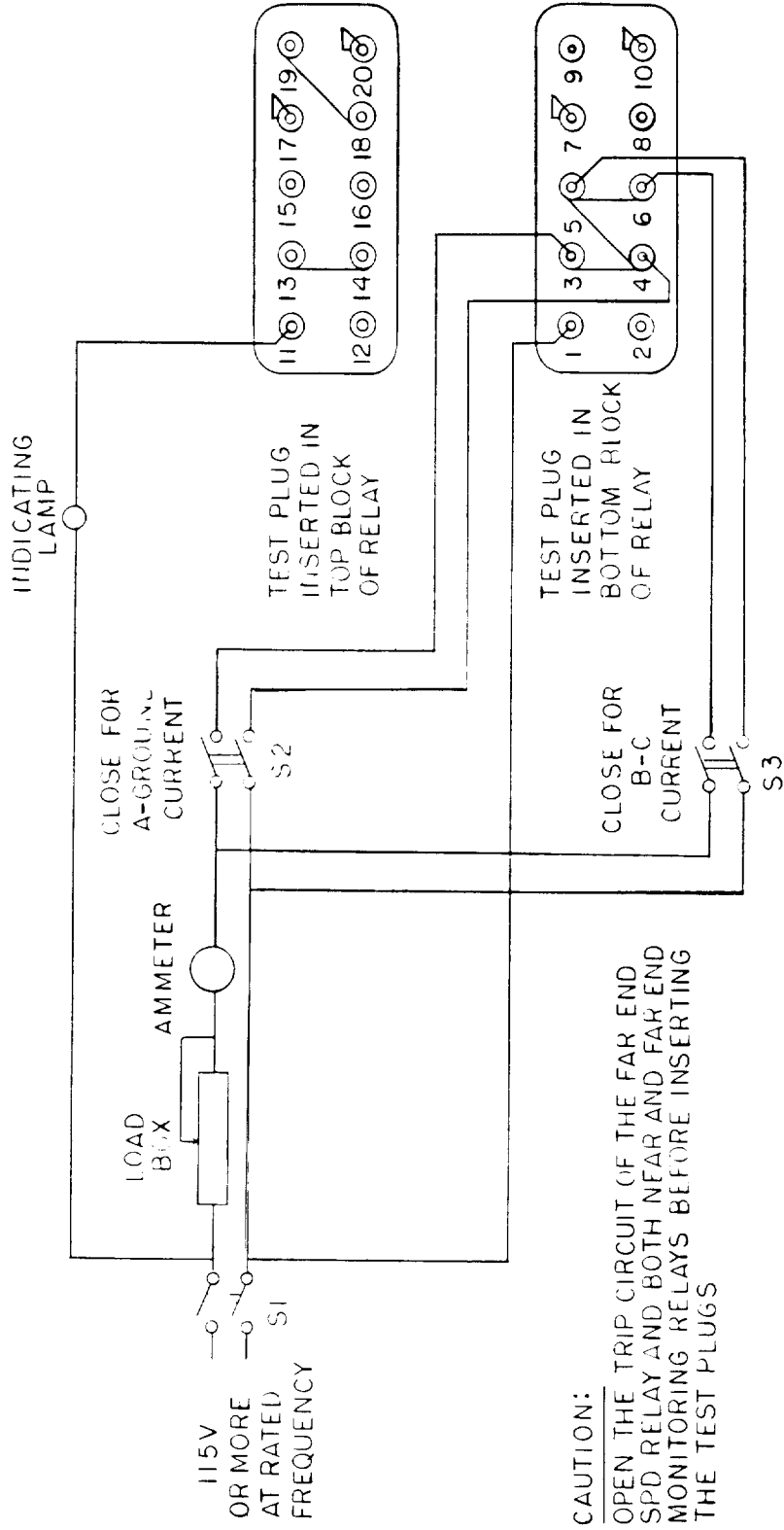

Figure 19 (0275A2042) Field Test Connections for Periodic Testing

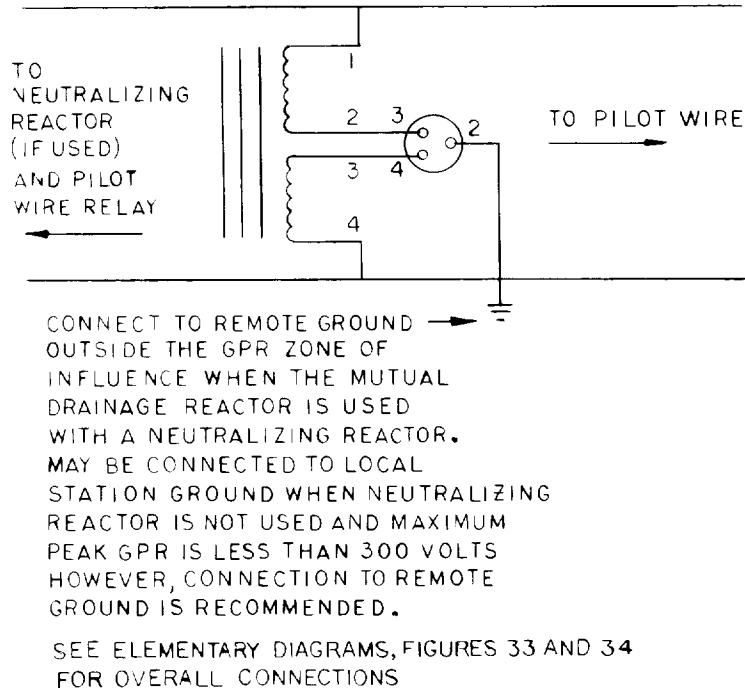
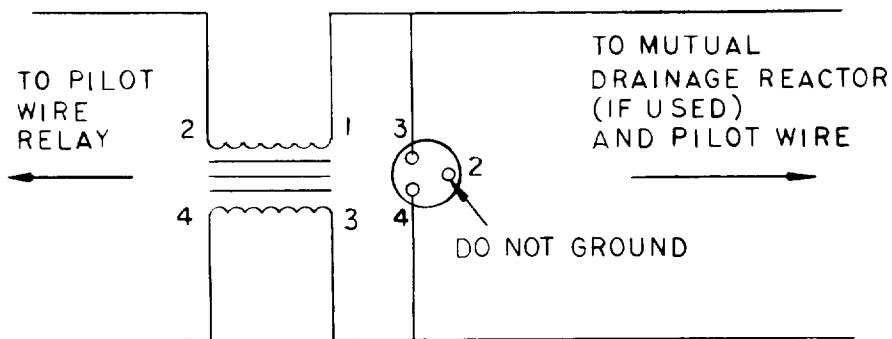

Figure 20 (0275A2039-1) External Connections Diagram for Mutual-Drainage Reactor



SEE ELEMENTARY DIAGRAMS, FIGURES 33 AND 34 FOR OVERALL CONNECTIONS

Figure 21 (0275A2040-1) External Connections Diagram for Neutralizing Reactor

GEK-49794

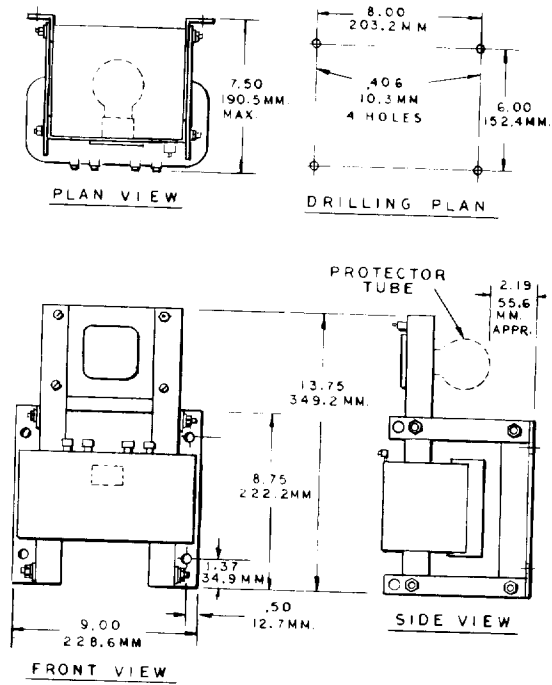

Figure 22A (0275A2044, Sh. 1 1) Outline and Mounting Dimensions for 60 Hertz Neutralizing Reactor

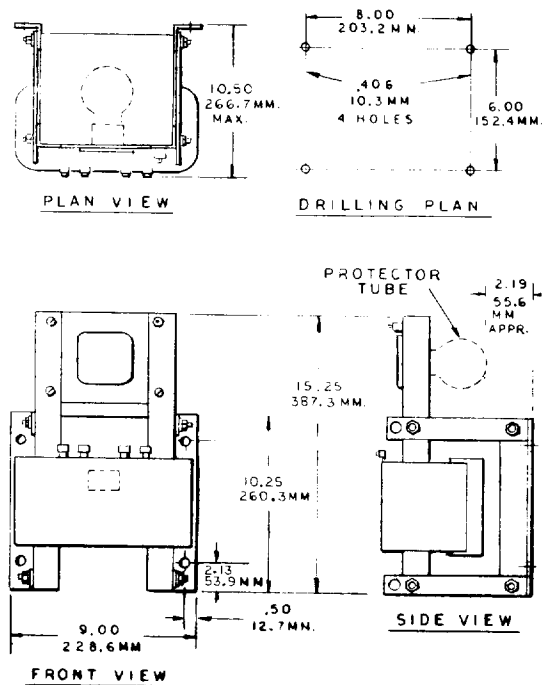

Figure 22B (0275A2044 Sh.2) Outline and Mounting Dimensions for 50 Hertz Neutralizing Reactor

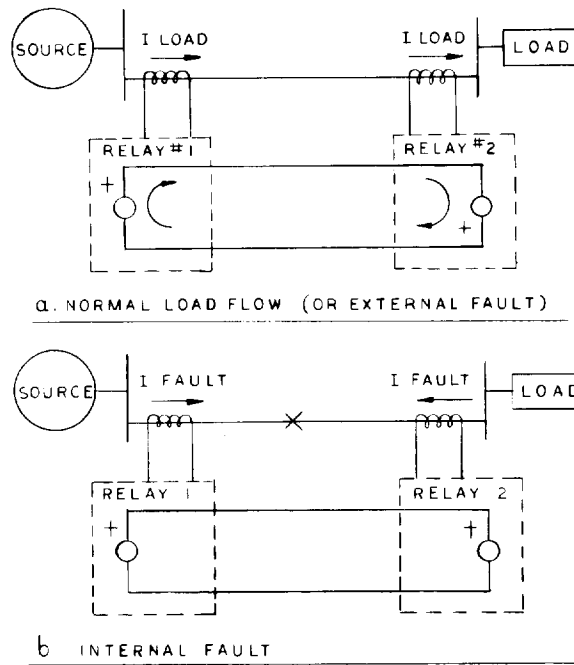

Figure 23 (0275A2041) Simplified External Connections Diagram Showing Relay Polarities

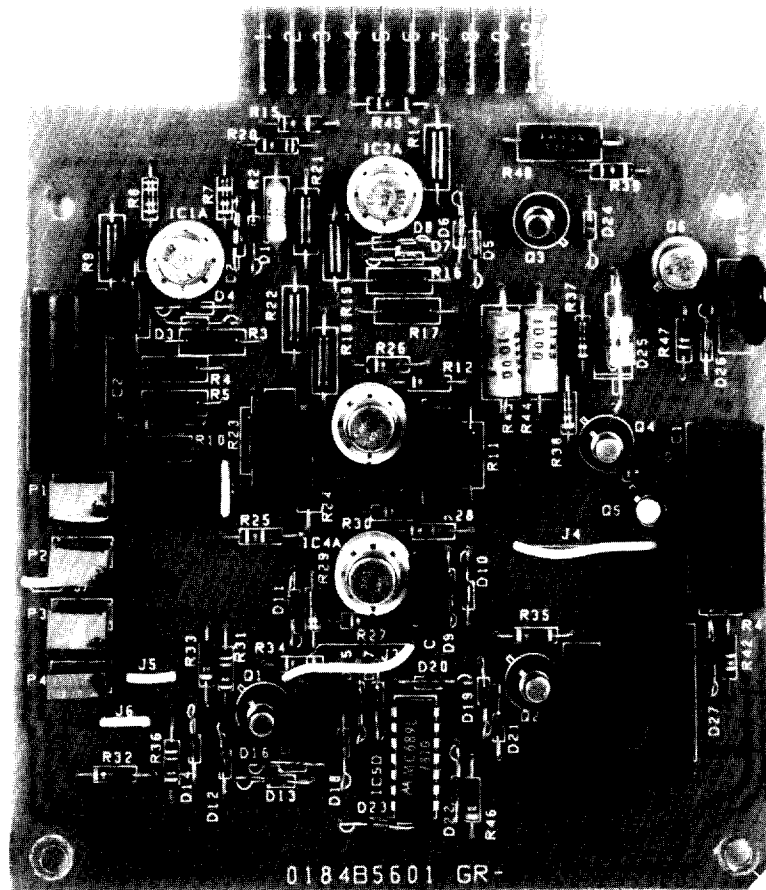
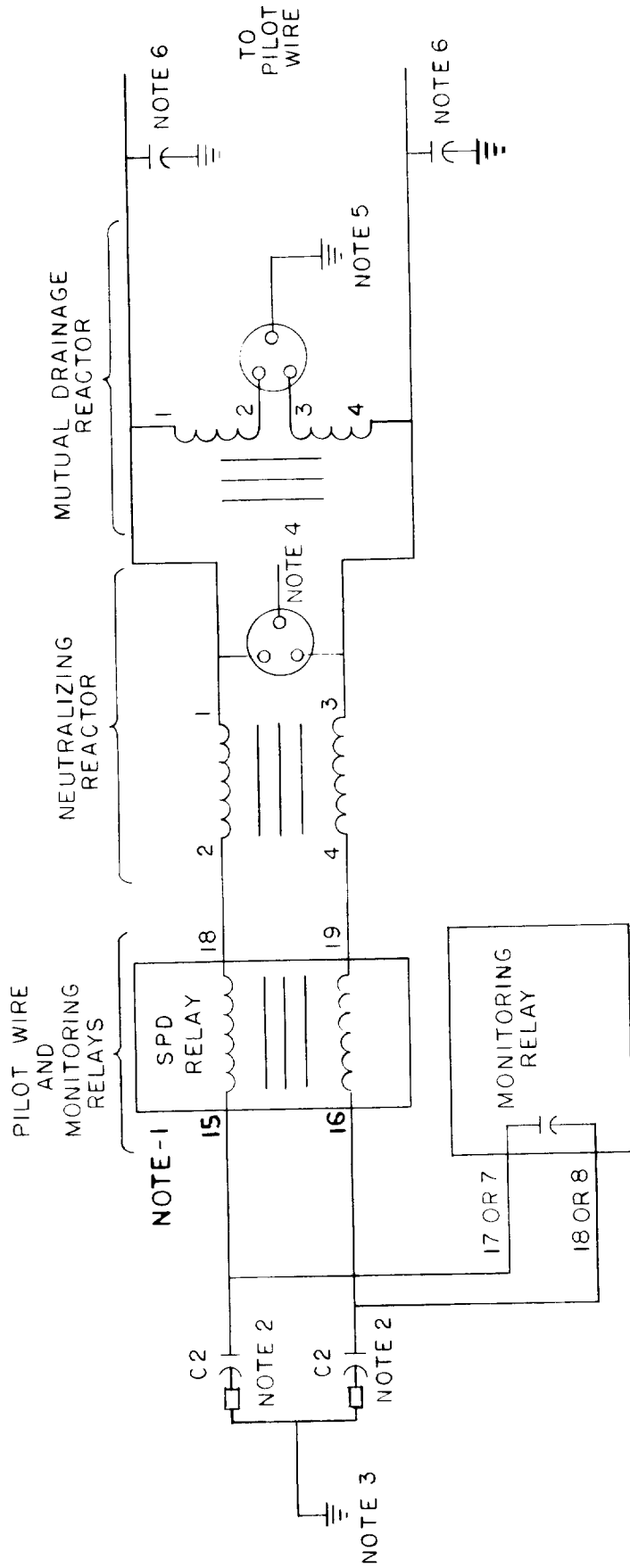

Figure 24 (8043291) Printed-Circuit Card



- NOTES**
- 1 WHEN MONITORING RELAYS ARE NOT USED CONNECT STUDS 15 AND 16 TOGETHER WITH A JUMPER
 - 2 C2 EXCITING CAPACITORS 1 μ FD ARE REQUIRED WHEN THE NEUTRALIZING REACTOR IS USED
 - 3 GROUND TO LOCAL STATION GROUND
 - 4 GAS TUBE THIRD TERMINAL MUST NOT BE GROUNDED
 - 5 THE CENTER TERMINAL OF THE GAS TUBE SHOULD BE CONNECTED TO LOCAL STATION GROUND WHEN THE NEUTRALIZING REACTOR IS NOT USED. IT SHOULD BE CONNECTED TO REMOTE GROUND OUTSIDE THE ZONE OF INFLUENCE IF THE NEUTRALIZING REACTOR IS USED
 - 6 EXCITING CAPACITORS ARE REQUIRED ONLY IF THE NEUTRALIZING REACTOR IS USED AND IF THE CAPACITANCE OF THE PAIR TO GROUND IS NOT SUFFICIENT TO EXCITE THE NEUTRALIZING REACTOR, THEY SHOULD BE CONNECTED TO REMOTE GROUND OUTSIDE THE ZONE OF INFLUENCE AND SHOULD NOT BE LARGER THAN REQUIRED TO EXCITE THE NEUTRALIZING REACTOR.

Figure 26 (0275A2043-1) Connections of External Pilot-Wire Protection Equipment

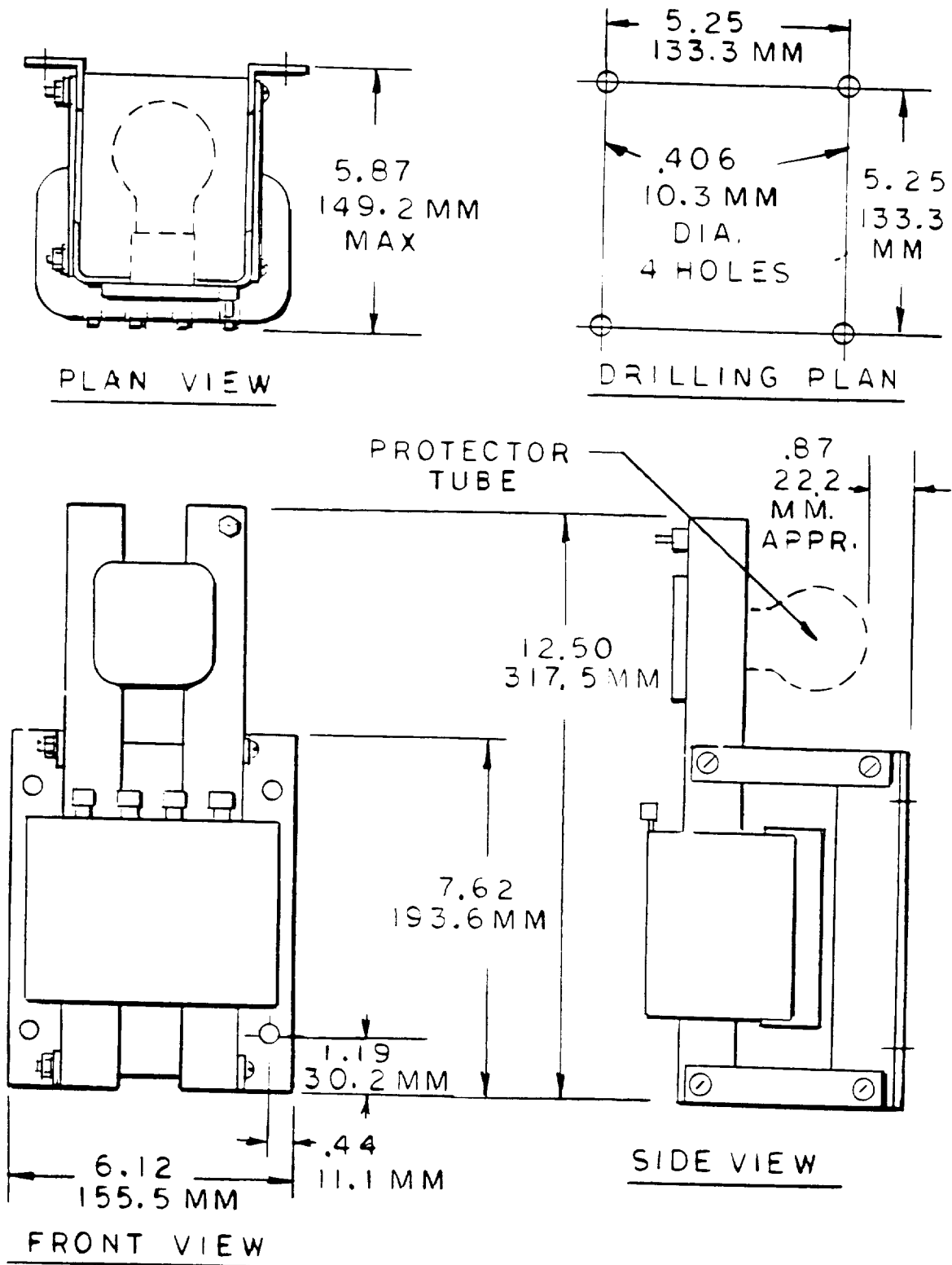

Figure 27A (0275A2045, Sh. 1 1) Outline and Mounting Dimensions for 60 Hertz Mutual-Drainage Reactor

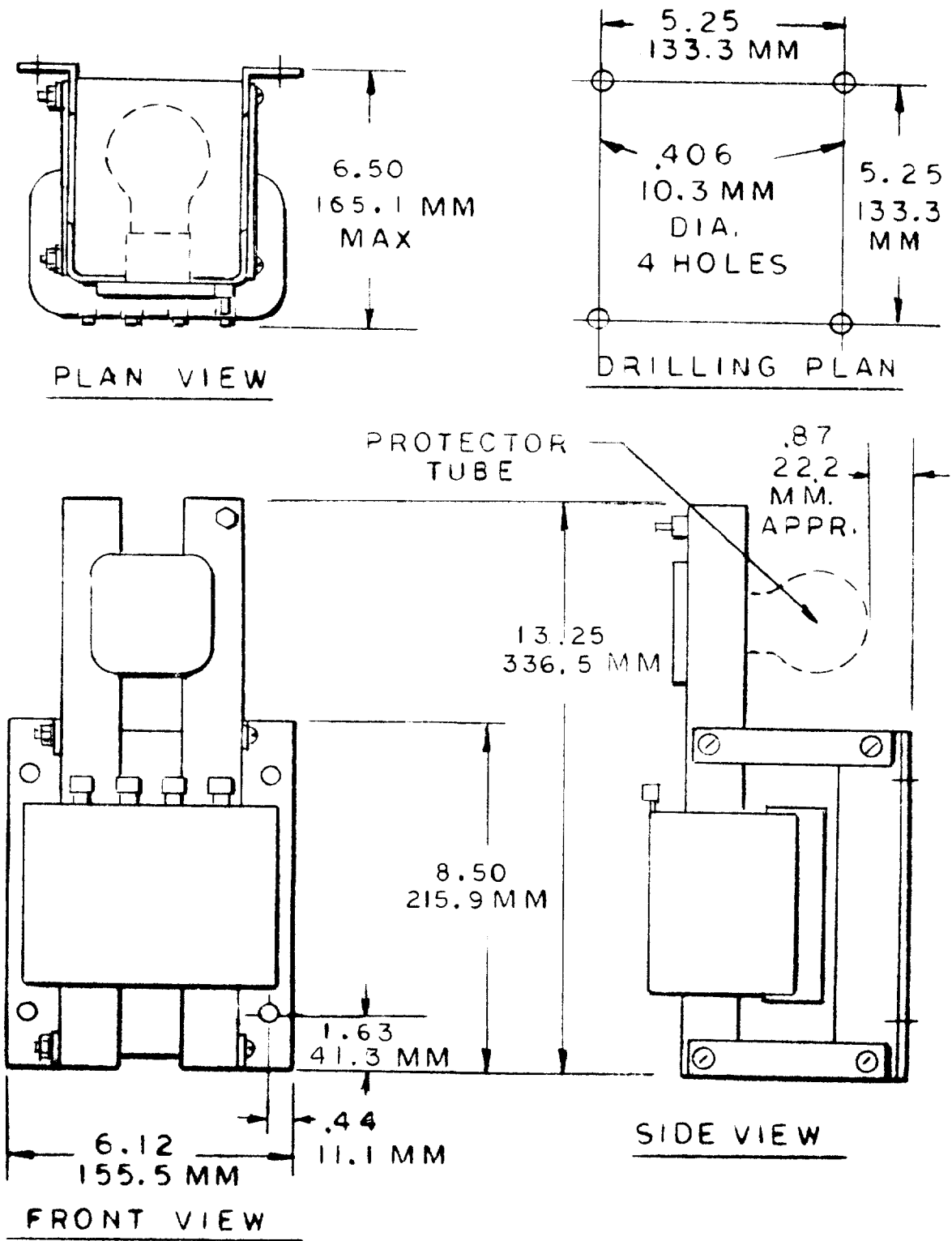

Figure 27B (0275A2045, Sh. 2) Outline and Mounting Dimensions for 50 Hertz Mutual-Drainage Reactor

CAPACITOR 0246A9023 P0100A
BRACKET 0302C0920 P027

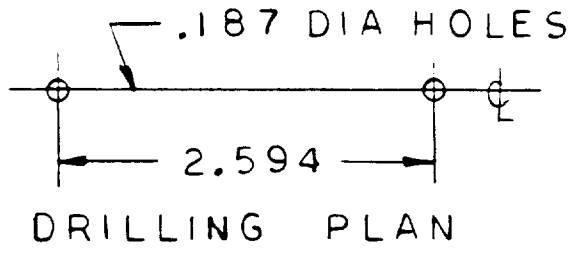
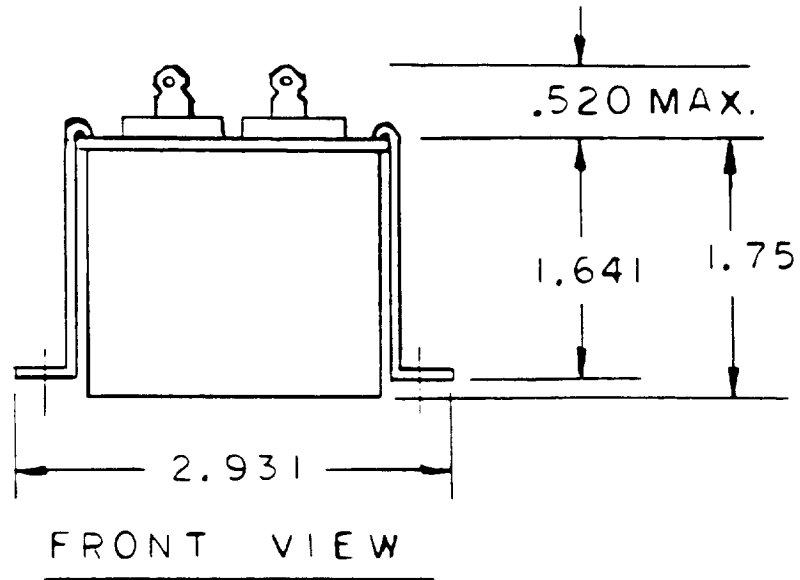
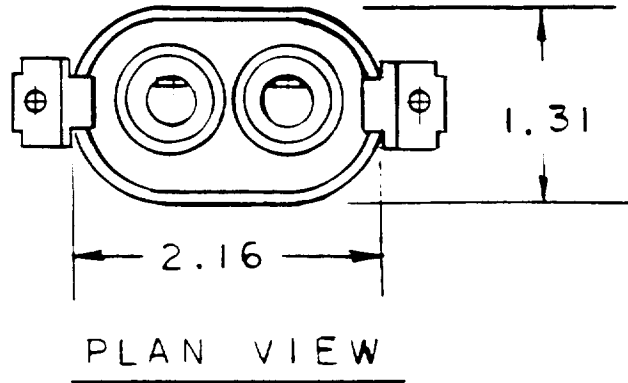
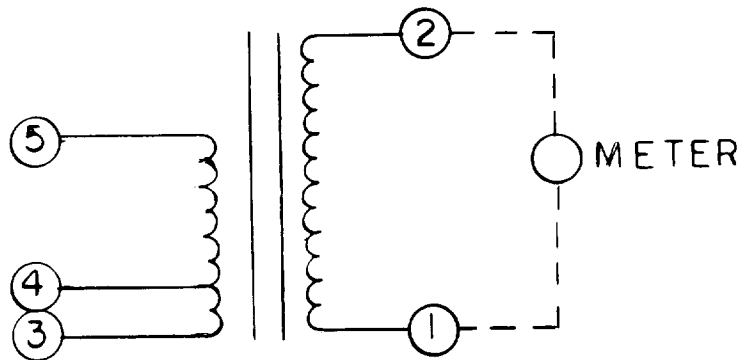
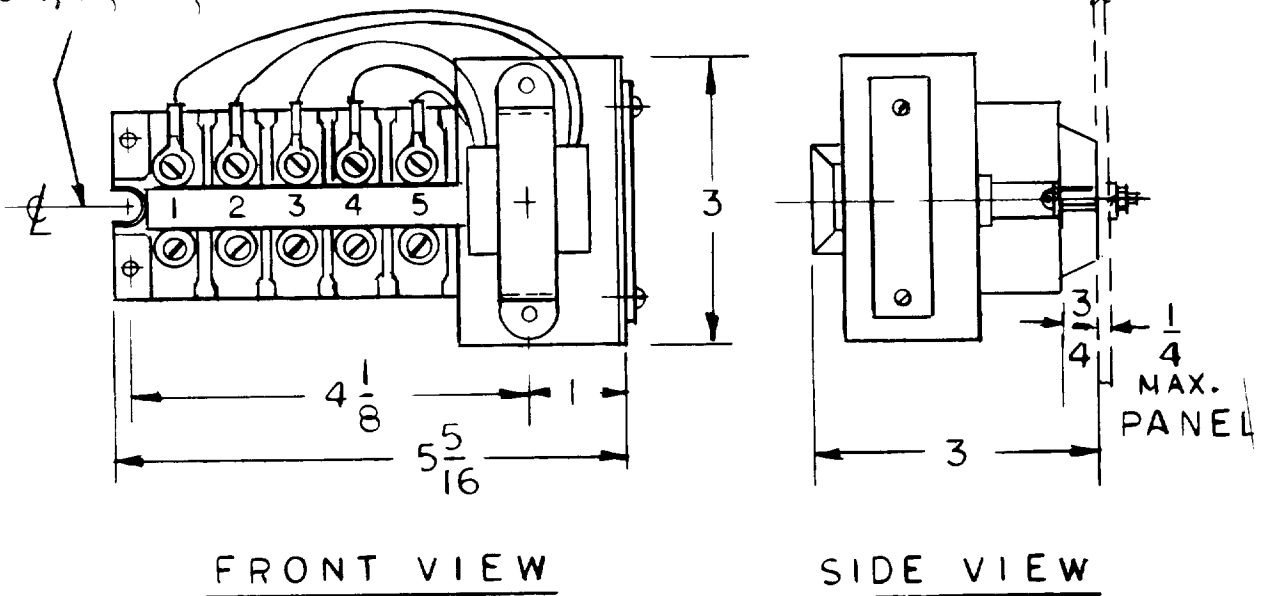
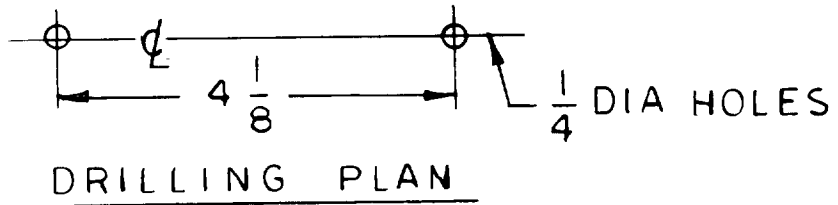

Figure 28 (0275A2047) Outline and Mounting Dimensions for External Exciting Capacitor

8-36
MOUNTING
HARDWARE
SCR, W, LW, NUT



CONNECT TO 3 AND 4 FOR 25MA FULL SCALE
CONNECT TO 3 AND 5 FOR 5MA FULL SCALE

Figure 29 (0273A9068) Outline, Panel-Drilling Dimensions and Electrical Connections Diagram for External AC Milliammeter Auxiliary Transformer

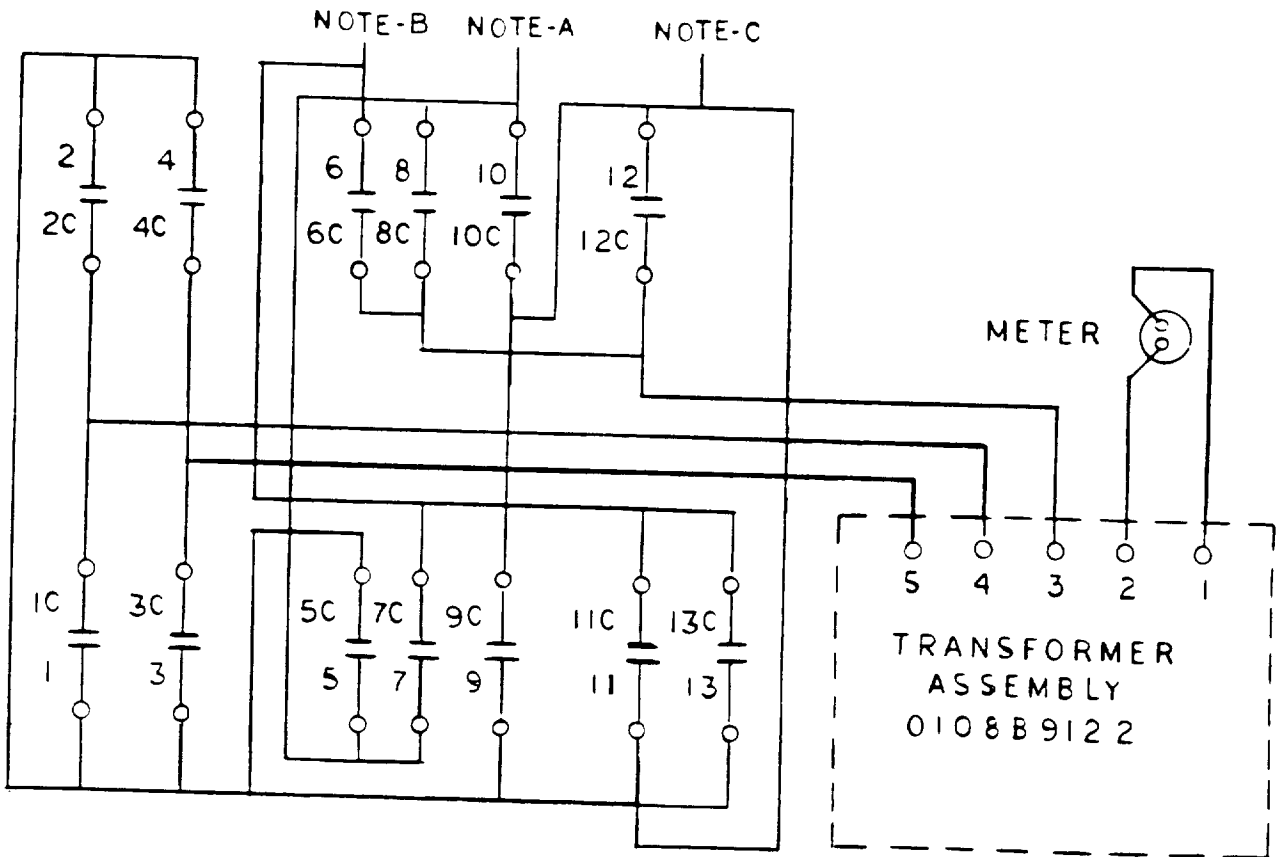
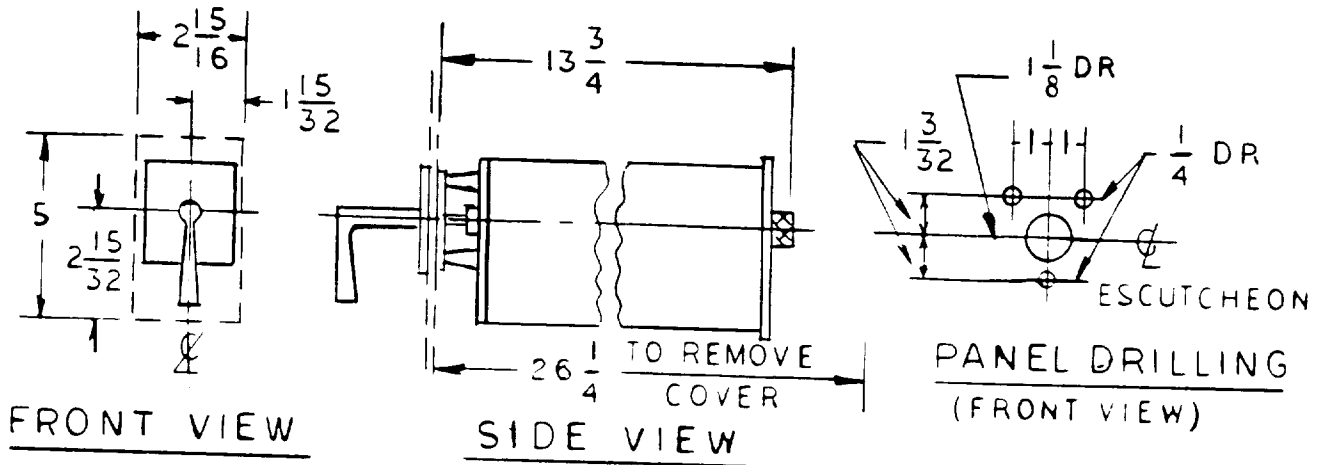

NOTE-A TO LOCAL SPD RELAY STUD 18

NOTE-B { TO LOCAL SPD RELAY STUD 19 AND VIA PILOT
WIRE TO REMOTE SPD RELAY STUD 19

NOTE-C VIA PILOT WIRE TO REMOTE RELAY STUD 18

Figure 30 (0273A9070-1) Outline, Panel-Drilling Dimensions and Electrical Connections Diagram for External AC Milliammeter Switch

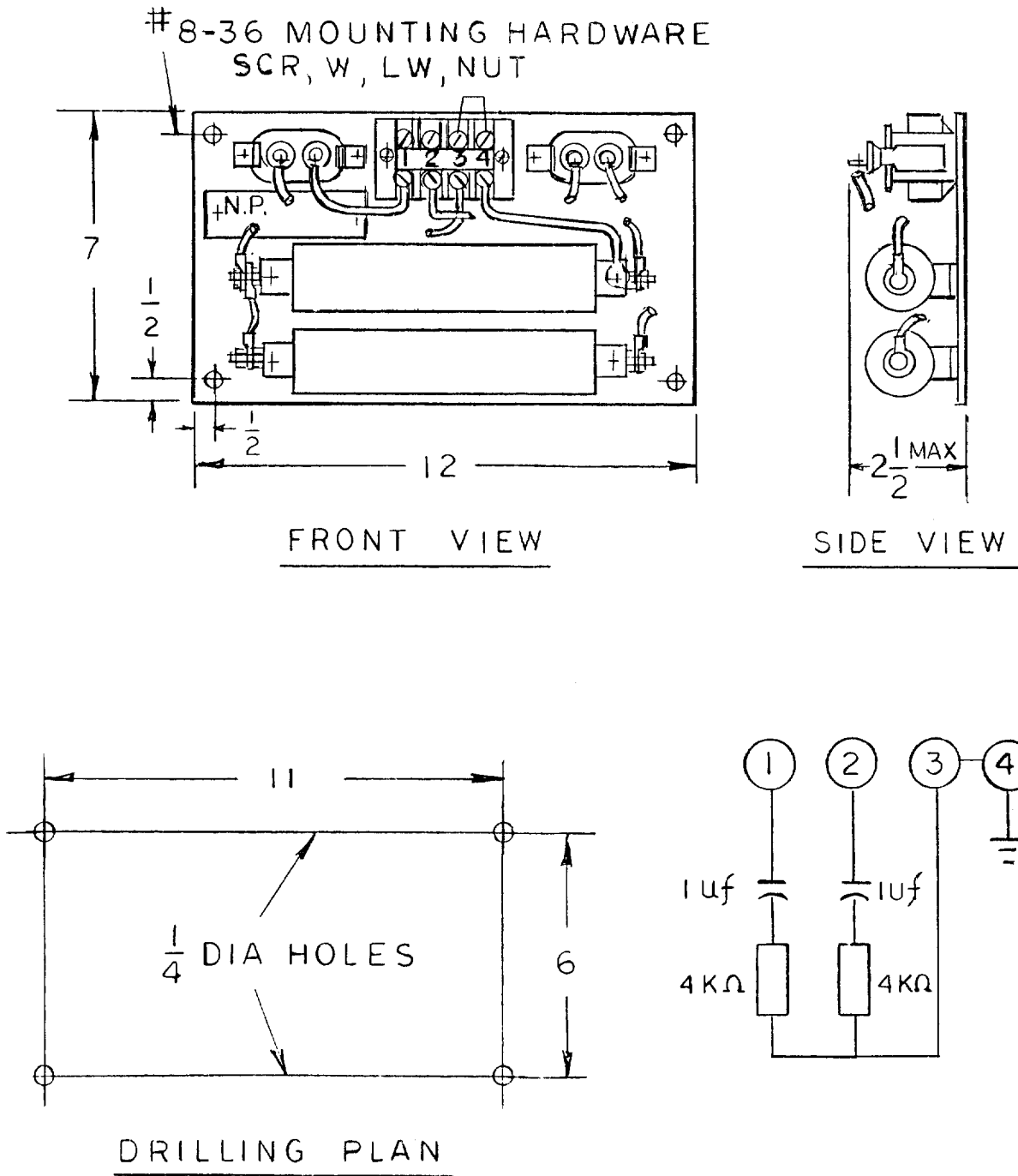

Figure 31 (0273A9067 [1]) Outline, Panel-Drilling Dimensions and Electrical Connections Diagram for External Neutralizing Transformer Exciting Package

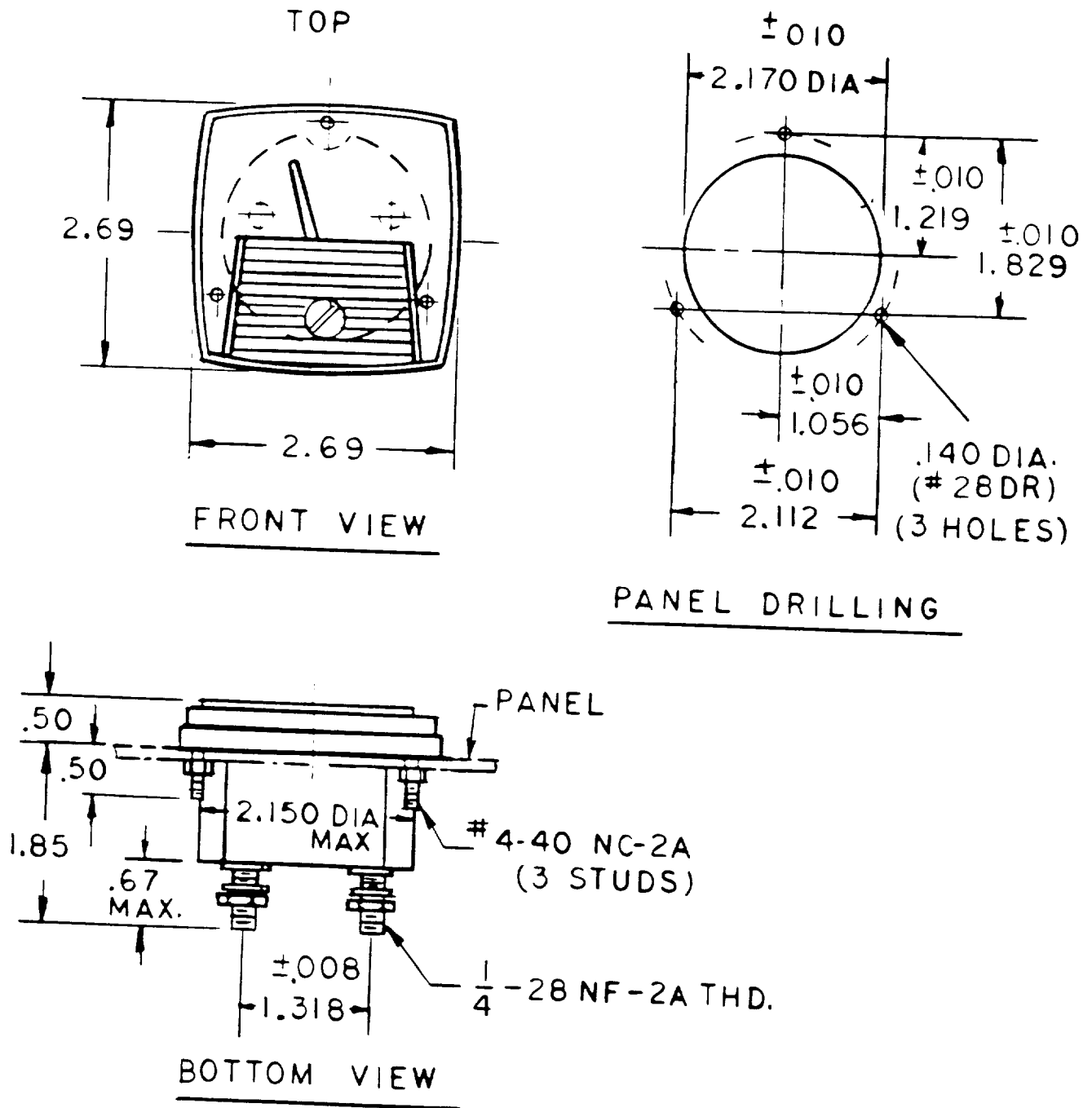
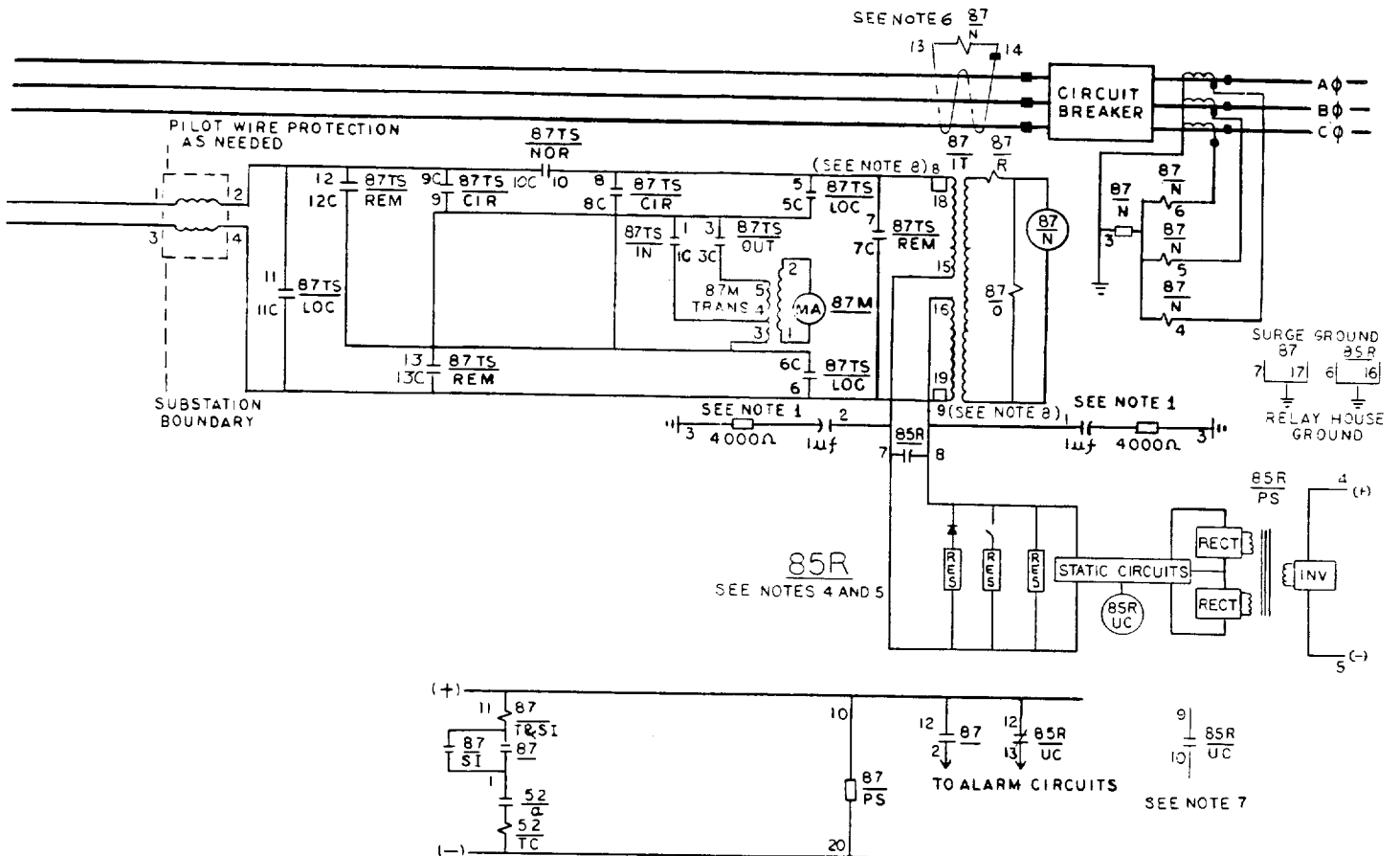

Figure 32 (0273A9083) Outline and Panel-Drilling Dimensions for External AC Milliammeters



87TS 0273A8437G1 SB10					
TEST SWITCH			AC CHECK		
CONT. NO	REM*	CIR*	NOR*	LOC	
1 1C 2C 2					SEE NOTE 2
3 3C 4C 4					SEE NOTE 2
5 5C 6C 6				X	X
7 7C 8C 8	X	X	X		
9 9C 10C 10	X	X	X	X	X
11 11C 12C 12	X	X			X
13 13C	X	X			

LEGEND			
DEVICE NO.	TYPE	INC ELEM	DESCRIPTION
87	SPD11A		PILOT WIRE RELAY NETWORK
	N		NETWORK
	O		OPERATE FUNCTION
	R		RESTRAINT FUNCTION
	IT		INSULATING TRANSF
	T&S		TARGET AND SEAL IN
	PS		POWER SUPPLY
87TS			AC CONNS. TEST SW
87M			AC CONNS. METER
87M TRANS			TRANSF FOR METER
85T SPA11A			MONITOR REL TRANSMIT END
	UC		UNDER CURRENT UNIT
	OC		OVER CURRENT UNIT
	G		GROUND DETECTOR UNIT
	PS		POWER SUPPLY
85R SPA12A			MONITOR RELAY RECEIVE END
	UC		UNDER CURRENT UNIT
	PS		POWER SUPPLY
87PR			PADDING RESISTOR (SEE NOTE 3)

DEVICE	INTERNAL CONNECTIONS	OUTLINE
SPD11A	0269A3024	006209274
SPA11A	0275A3240	006209272
SPA12A	0275A3242	006209272
METER	-	0273A9083
TEST SW	0273A9070	0273A9070
METER TRANS	0273A9068	0273A9068

Figure 33B (0138D2454[4]) Typical Elementary Diagram of External Connections

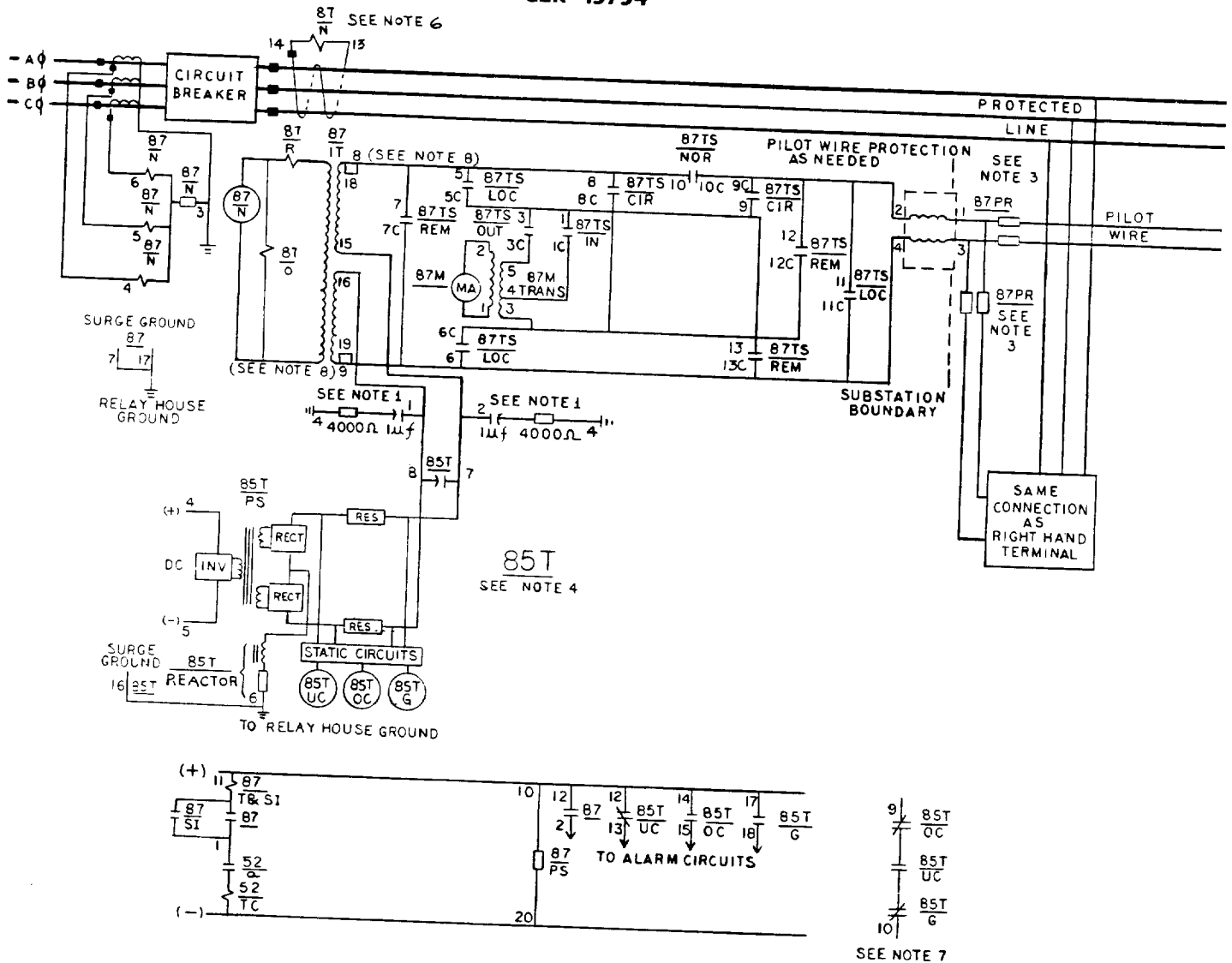

NOTE 1 THESE CAPACITORS AND RESISTORS REQUIRED ONLY IF NEUTRALIZING REACTORS ARE USED.
 THESE RESISTORS AND CAPACITORS ARE SUPPLIED ON EXCITING PLATE SUPPLIED WITH NEUTRALIZING REACTOR 0257A9787 6003

NOTE 2 CONTACTS 1 AND 2 ARE CLOSED WHEN SWITCH HANDLE IS IN THE IN POSITION. CONTACTS 3 AND 4 ARE OPEN WHEN SWITCH HANDLE IS IN THE IN POSITION. CONTACTS 1 AND 2 OPEN AFTER CONTACTS 3 AND 4 CLOSE WHEN HANDLE IS PULLED OUT. SWITCH SPRING RETURNS TO THE NORMAL POSITION AND TO THE IN POSITION

NOTE 3 FOR THREE TERMINAL LINES THE PILOT WIRE MUST BE PADDED SO THAT ALL THREE SECTIONS OF PILOT WIRE FROM RELAY TO MIDPOINT HAVE THE SAME SERIES RESISTANCE

NOTE 4 WHEN MONITORING RELAYS ARE NOT USED, CONNECT 87 STUD 15 TO 87 STUD 16

NOTE 5 OPEN LINK FOR THREE TERMINAL LINES

NOTE 6 RESIDUAL GROUND CT. WHEN USED FOR INCREASED GROUND CURRENT SENSITIVITY

NOTE 7 LOCKOUT CIRCUIT FOR SPD RELAY WHEN USED TO BE CONNECTED IN SERIES WITH 87 TRIP CIRCUIT

NOTE 8 CONNECT STUD 8 TO 18 AND 9 TO 19 OF SPD RELAY EXTERNAL TO THE RELAY CASE

NOTE 9 EACH RELAY CASE SHOULD BE CONNECTED TO THE RELAY HOUSE GROUND WITH A SEPARATE #12 OR LARGER COPPER CONDUCTOR OF MINIMUM LENGTH. CONNECT STUD 7 TO 17 OF SPA AND STUD 6 TO 16 OF SPA EXTERNAL TO THE CASE AND TO RELAY HOUSE GROUND WITH MINIMUM LENGTH #12 OR LARGER COPPER CONDUCTOR

Figure 34A (013802455 [4]) Typical Elementary Diagram of External Connections for Three-terminal Lines

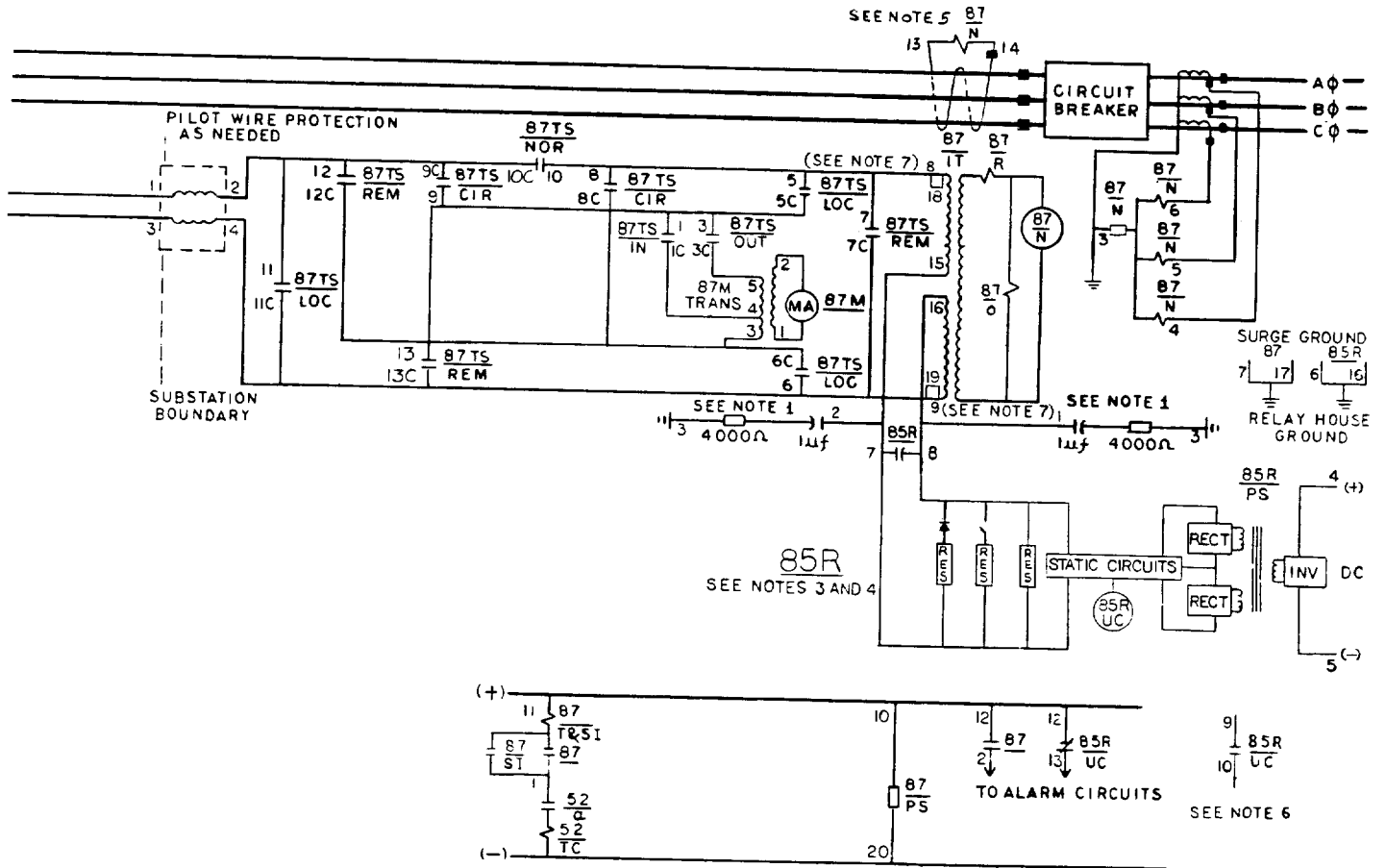

87TS 0273AB437G1 SB10						
TEST SWITCH			AC CHECK			
CONT. NO.	REM*	CIR*	NOR*	LOC		
1 1C 2C 2						SEE NOTE 2
3 3C 4C 4						SEE NOTE 2
5 5C 6C 6						
7 7C 8C 8	X	X	X		X	X
9 9C 10C 10	X	X	X		X	X
11 11C 12C 12	X	X		X	X	X
13 13C	X	X				

LEGEND		
DEVICE TYPE NO.	INC ELEM	DESCRIPTION
87 SPDI1A		PILOT WIRE RELAY
N		NETWORK
O		OPERATE FUNCTION
R		RESTRAINT FUNCTION
IT		INSULATING TRANSF.
T&S1		TARGET AND SEAL IN
PS		POWER SUPPLY
87TS		AC CONNS. TEST SW
87M		AC CONNS. METER
87M TRANS		TRANSF FOR METER
85T SPA11A		MONITOR REL. TRANSMIT END
UC		UNDER CURRENT UNIT
OC		OVER CURRENT UNIT
G		GROUND DETECTOR UNIT
PS		POWER SUPPLY
85R SPA12A		MONITOR REL. RECEIVE END
UC		UNDER CURRENT UNIT
PS		POWER SUPPLY

DEVICE	INTERNAL CONNECTIONS	OUTLINE
SPDI1A	0269A3024	006209274
SPA11A	0275A3240	006209272
SPA12A	0275A3242	006209272
METER	-	0273A9083
TEST SW	0273A9070	0273A9070
METER TRANS	0273A9068	0273A9068

Figure 34B (0138D2455 [4]) Typical Elementary Diagram of External Connections for Three-terminal Lines

PICK UP VS PILOT WIRE LENGTH
FOR A PILOT WIRE OPEN AT FAR END
TYPE SPD

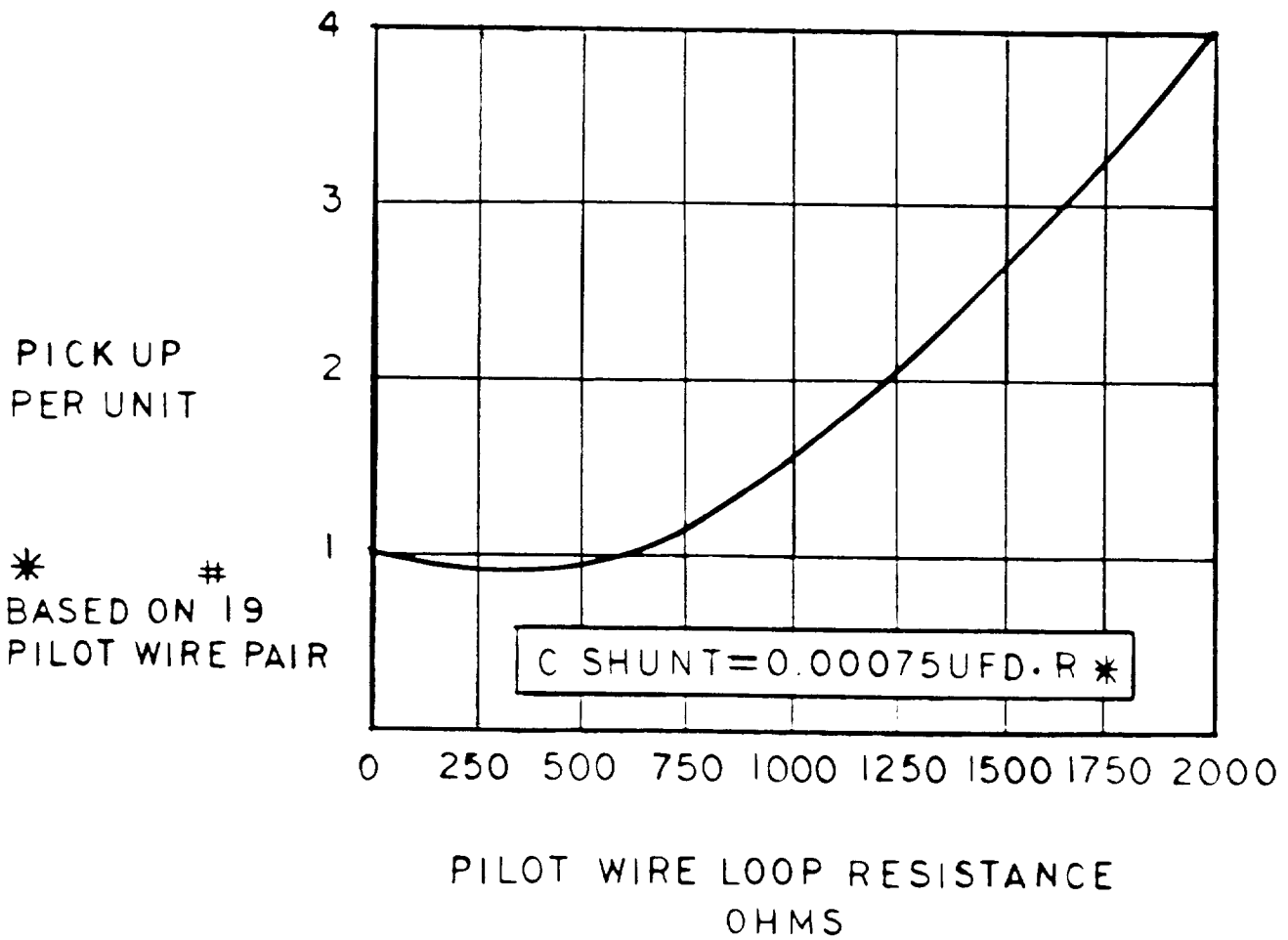

Figure 35 (0273A9127-1) Pickup Versus Pilot-Wire Length
with Far End of Pilot Wire Open



GE Power Management

**215 Anderson Avenue
Markham, Ontario
Canada L6E 1B3
Tel: (905) 294-6222
Fax: (905) 201-2098
www.ge.com/indsys/pm**