



INSTRUCTIONS

GEK-41958 B
Supersedes GEK-41958 A

STATIC RELAY POWER SUPPLY

TYPE SSA51A

GENERAL  ELECTRIC

CONTENTS

INTRODUCTION.....3

APPLICATION.....3

RATINGS.....3

BURDENS.....3

DESCRIPTION.....3

 DC TO AC INVERTER.....4

 RECTIFIER AND REGULATOR CIRCUITS.....4

 ALARM CIRCUITS.....4

 OVERCURRENT PROTECTION.....4

 OVER VOLTAGE PROTECTION.....4

 EXTERNAL BATTERY CLAMP.....4

 A. DESCRIPTION.....4

 B. NORMAL OPERATING CONDITION.....5

 C. SOLENOIDS AS SURGE VOLTAGE SOURCES.....5

 D. BATTERY CLAMP OPERATION.....5

 E. LOW ENERGY TRANSIENTS BETWEEN BATTERY LEADS.....5

CONSTRUCTION.....5

RECEIVING, HANDLING AND STORAGE.....7

DC POWER SUPPLY

TYPE SSA51A

INTRODUCTION

The Type SSA51A POWER SUPPLY is designed for operation from the station battery to provide an isolated, regulated low-voltage dc supply for use with rack mounted static relays. Components of the power supply are mounted in a metal enclosure as shown in Figure 1, designed for mounting on a standard 19 inch rack. The power supply unit is 4 rack units (7") high and 14 inches deep.

APPLICATION

Type SSA51A POWER SUPPLY is designed for use with static protective relays which require an isolated, regulated dual 15 volt dc supply (± 15 volts with midpoint reference) for logic circuit operation. It is recommended that a battery clamp be used in conjunction with static relays. One clamp should be used per battery or per physical location. The battery clamp should be connected to the battery so that it is always connected to the dc supply of the equipments the clamp is to protect and cannot be isolated by switches or fuses in the dc distribution system.

RATINGS

Type SSA51A POWER SUPPLY is designed for operation from station battery voltages of 48, 125, or 250 volts dc. The power supply output voltages have nominal values with respect to the reference bus of ± 15 volts dc. The positive and negative output circuits each has a maximum current rating of 3.0 amperes. The alarm contacts will make and carry 3 amperes continuously. The contacts will interrupt 180 VA resistive (60 VA inductive).

BURDEN

Maximum current drain of the SSA51A from the station battery is given in the table below.

BATTERY VOLTAGE	CURRENT BURDEN
48 VDC	AMP
125 VDC	2.0 AMP
250 VDC	AMP

DESCRIPTION

Components of the power supply may be divided into four functional groups (1) DC to AC inverter, (2) positive rectifier and regulator circuit, (3) negative rectifier and regulator circuit, and (4) over-under voltage alarm protection circuits. The internal connections are shown in Figure 2. The Component locations are shown in Figure 3.

These instructions do not purport to cover all details or variations in equipment nor to provide for every possible contingency to be met in connection with installation, operation or maintenance. Should further information be desired or should particular problems arise which are not covered sufficiently for the purchaser's purposes, the matter should be referred to the General Electric Company.

To the extent required the products described herein meet applicable ANSI, IEEE and NEMA standards; but no such assurance is given with respect to local codes and ordinances because they vary greatly.

DC TO AC INVERTER

Transistors Q_1 and Q_2 , in conjunction with the converter card (Fig. 4), form a DC to AC inverter circuit, whose frequency is approximately 1000 Hz. Transformer T1 provides isolation between the station battery and the desired secondary voltage (33V).

When Q_2 begins to conduct, the voltage induced in the auxiliary winding B3-E3 sustains Q_1 in cutoff and Q_2 in saturation. When the transformer T₁ saturates, the decreasing voltage across the driving winding B1-E1 induces a voltage in the auxiliary winding B3-E3 which turns Q_1 on. The cycle then continues with Q_1 and Q_2 conducting alternately.

RECTIFIER AND REGULATOR CIRCUITS

Diodes D4 and D5 form the positive rectifier. Transistors Q3, Q4, and Q5 along with IC1 (Fig. 2) form a series regulator circuit which provides the +15 VDC logic voltage. The magnitude of the regulated voltage can be varied by potentiometer P1 which is mounted on the positive regulator card. The internal connections of the regulator card are shown in Figure 5.

Diodes D6 and D7 form the negative rectifier. Transistors Q6, Q7 and Q8 along with IC2 form the negative series regulator circuit which produces a -15VDC logic voltage. The magnitude of the negative logic voltage can be adjusted by potentiometer P2 on the negative regulator card. The internal connections of the negative regulator card are shown in Figure 6.

ALARM CIRCUIT

The Type SSA51A power supply contains an under-over voltage alarm on the regulated output. The alarm is formed by zener diodes Z3, Z4 and Z5 and the OV and UV telephone relays. The alarm operates a red lamp on the power supply and transfer contacts which are wired to the PA terminal block on the rear of the unit for connection to a station alarm.

When the voltage between the positive and negative regulated outputs is between 28 and 32 VDC (normal operating conditions), Z3 and Z5 are conducting and the UV telephone relay is energized. Z4 is not conducting and the OV relay is deenergized. If the voltage exceeds 32 VDC the OV telephone relay operates, if the voltage falls below 28 VDC the UV relay is deenergized.

OVERCURRENT PROTECTION

A double pole breaker is connected to the regulator circuit with one pole in each circuit. Each pole has a 3 ampere rating. The two poles are mechanically connected so that both logic voltages will be deenergized if either trips. When the breaker trips, the alarm circuit is activated by the loss of regulated DC voltage. The circuit breaker is identified as BRI-A and BRI-B in Figure 2.

OVER VOLTAGE PROTECTION

The logic circuits powered by the SSA51A are protected against over-voltages by zener diodes Z1 and Z2. When the regulated output approaches +17 VDC (-17 VDC for the negative regulator) Z1 begins to conduct (Z2 for the negative). The zener diodes provide a clamp for the regulated outputs. If the regulator attempts to produce a voltage higher than the clamp level, excessive current will be drawn causing the overcurrent circuit breaker to trip.

EXTERNAL BATTERY CLAMP

NOTE: The battery clamp is not included in the Type SSA51A power supply and may not be supplied on all equipments using the Type SSA51A power supply.

A. DESCRIPTION

The battery clamp provides protection against transient voltages which may appear on the station battery leads at the relay or cabinet external connections terminal block. A typical battery clamp internal connection diagram is shown in Figure 7 and an outline diagram is shown in Figure 8.

The function of the battery clamp is twofold. The first is to absorb transients which may appear between the battery leads. This is accomplished without allowing a significant voltage change between either lead and the Relay Surge Ground.

Second, it prevents an incoming surge voltage from causing either the positive or negative battery lead to be driven more than a limited potential difference from the relay ground. The positive battery supply lead can not assume a positive potential greater than battery voltage, nor a negative potential of more than one volt relative to Relay Surge Ground; and the negative battery supply lead can not assume a negative potential greater than battery voltage, nor a positive potential or more than one volt relative to Relay Surge Ground.

B. NORMAL OPERATING CONDITION

Under normal operating conditions in most stations, the battery voltage is divided by ground indicating lamps, or by other high impedance devices, so that each battery lead is one half of the battery voltage relative to the Relay Surge Ground. The battery clamp, which is connected to the supply circuits as shown in Figure 4A, rests with capacitors C_1 , C_2 , C_3 , and C_4 charged to one half of battery voltage. Diodes D_1 and D_2 have this voltage impressed across them in the reverse or blocking direction.

C. SOLENOIDS AS SURGE VOLTAGE SOURCES

The voltage induced in a solenoid operating coil when the current through the coil is interrupted is determined only by the rate at which the coil current is forced to decay. If the interrupting contact parts rapidly enough, and if the insulation surrounding the contact is weak, this induced voltage may be sufficient to establish an arc to ground. The voltage drop across the arc will be relatively low and constant. If the battery clamp is not used, the remaining impedance in the arc current path is the battery ground lamp. Figure 9B illustrates these conditions.

The collapsing magnetic field of the coil tends to maintain the original magnitude of current flowing in the coil turns, and this current must be driven through the high impedance of the ground lamp. Consequently, a high voltage appears across the lamp. The result is a large voltage swing on the battery leads with respect to ground. The polarity of this voltage causes the lead to which the coil is directly connected to assume a potential with respect to ground which is opposite from normal.

D. BATTERY CLAMP OPERATION

If the conditions described in Section C and shown in Figure 9B exist, the negative battery lead might be driven as much as 1.5KV positive with respect to ground (or the positive lead driven negative with respect to ground). Placing a low impedance, such as the forward impedance of a rectifier, between the lead and ground, in parallel with the ground lamp will limit the voltage swing of that lead. This is shown in Figure 9C.

With this connection, the solenoid current has a low impedance path through which to flow to dissipate the energy in its magnetic field. The induced voltage is thereby kept low, and the battery lead is held within one volt of ground potential, one volt being the approximate voltage drop across the rectifier. Since one battery lead is clamped at ground, the maximum value that the other lead can assume is either plus or minus battery voltage depending upon which lead is grounded. If a rectifier is placed between each lead and ground, both leads will be clamped at ground potential.

E. LOW ENERGY TRANSIENTS BETWEEN BATTERY LEADS

In the previous paragraphs, it was assumed that the battery leads were held by the battery at a constant potential difference. Because these leads have self-inductance, a current flow in them results in stored energy that must be dissipated when the current is interrupted. Since the inductance is small, the total stored energy is low, but the voltage of self-inductance when the current is interrupted rapidly may be very high. However, this energy can be absorbed by the battery clamp capacitor (C_5) with only a small change in the voltage between the leads. The stored energy is thereby transferred to the capacitors and ultimately dissipated in the load circuit without a significant voltage change between the Relay Surge Ground and either of the battery leads at the location of the ground lamps.

CONSTRUCTION

All power supply components, are mounted in a metal enclosure four rack units in height. Both the cover and the bottom of the power supply are perforated steel to allow for ventilation of the heat sinks.

External connections to the power supply are made at the back of the unit. Sockets for interconnecting the power supply output with the static relay logic units are marked PS. Arrangement of these sockets are shown on the SSA51A component location drawing in Figure 3.

The PA terminal strip on the rear of the SSA51A power supply has screw terminals for external connections. The power supply unit will normally be supplied with a cable attached to this terminal strip with a drawout relay cable block on the end of the cable. This arrangement is designed for use with a test and connection receptacle. All receptacles for a terminal of equipment are usually mounted on a common test panel.

The cable block is inserted into the test and connection receptacle from the rear and is locked in place with two mounting screws. A standard drawout case connection plug then completes the circuit when inserted from the front of the panel. A Type XLA relay test plug may be used to make tests in the conventional manner.

Three test points are brought out to the front panel providing access to the two output voltages and reference.

CAUTION: THE LOGIC SYSTEM SIDE OF THE TYPE SSA51A DC POWER SUPPLY USED WITH STATIC RELAY EQUIPMENT IS ISOLATED FROM GROUND. IT IS A DESIGN CHARACTERISTIC OF MOST ELECTRONIC INSTRUMENTS THAT ONE OF THE SIGNAL INPUT TERMINALS IS CONNECTED TO THE INSTRUMENT CHASSIS. IF THE INSTRUMENT USED TO TEST THE RELAY EQUIPMENT IS ISOLATED FROM GROUND, ITS CHASSIS MAY HAVE AN ELECTRICAL POTENTIAL WITH RESPECT TO GROUND. A TEST INSTRUMENT WITH A GROUNDED CHASSIS WILL NOT AFFECT THE TESTING OF THE EQUIPMENT. A SECOND GROUND CONNECTION TO THE EQUIPMENT, SUCH AS A TEST LEAD INADVERTENTLY DROPPING AGAINST THE RELAY CASE, MAY CAUSE DAMAGE TO THE LOGIC CIRCUITRY. NO EXTERNAL TEST EQUIPMENT SHOULD BE LEFT CONNECTED TO THE STATIC RELAYS WHEN THEY ARE IN PROTECTIVE SERVICE, SINCE TEST EQUIPMENT GROUNDING REDUCES THE EFFECTIVENESS OF THE ISOLATION PROVIDED.

The following tests should be made to insure that the SSA51A power supply is operating correctly.

1. Connect (+) battery lead to PA2, (-) battery lead to PA3, and station ground to PA1. Check that overcurrent circuit breaker is closed.
2. The power supply output voltages may be checked at the test jacks provided on the front of the unit. All voltages are with respect to reference (TJ2). With rated battery voltage applied the positive output voltage at TJ3 should be (+) 15 volts, corrections can be made by adjusting pot P1 on the front regulator card; the negative output voltage at TJ1 should be (-) 15 volts, corrections can be made by adjusting pot P2 on the rear regulator card.
3. Power supply regulation can be checked by connecting an adjustable load resistor across positive output pins 1 and 4 of any PS socket. Apply rated DC voltage, adjust load resistor for 3.00 ampere, and check that the positive output voltage reading is between (+) 14.9 - 15.1 volts DC. Reduce input voltage to 80 percent of rating with same load and check that the positive output voltage reading is between (+) 14.7 - (+) 15.1 volts DC. The negative output circuit regulation can be checked in a similar manner after connecting the adjustable load resistor across pins 1 and 3 of the PS socket. Output voltage readings are to be between (-) 14.7 - (-) 15.1 volts DC.
4. The operation of the output breaker (BR1) can be checked by connecting an adjustable load resistor across one of the output circuits, adjust the load for 4 amperes and check for a trip in 10 seconds or less. This test can be repeated on the other output circuit to check both poles of the breaker.
5. The under voltage alarm relay may be checked as follows:
 - a. Decrease the input DC voltage until the voltage between the regulated outputs drops below the rated alarm voltage (approximately 28 volts). This will cause the alarm relays to drop out, energizing the alarm light.
 - b. Open the breaker (BR1) on the front panel. This again will energize the alarm lamp.
6. To test the overvoltage alarm circuits, it is necessary to remove the unit top cover, and increase the output voltage by adjusting P1 on the positive regulator card or P2 on the negative regulator card. The overvoltage alarm should operate when Z_4 begins to conduct (approximately 32 volts).

RECEIVING, HANDLING AND STORAGE

* This power supply will normally be supplied as a part of a static relay equipment, mounted in a rack or cabinet with other static relays and test equipment. Immediately upon receipt of a static relay equipment, it should be unpacked and examined for any damage sustained in transit. If injury or damage resulting from rough handling is evident, file a damage claim at once with the transportation company and promptly notify the nearest GENERAL ELECTRIC SALES OFFICE.

Reasonable care should be exercised in unpacking the equipment. If the equipment is not to be installed immediately, it should be stored indoors in a location that is free from moisture, dust, metallic chips, and severe atmospheric contaminants.

Just prior to final installation the shipping support bolt should be removed from each side of all relay units, to facilitate possible future unit removal from maintenance. These shipping support bolts are approximately 8 inches back from the relay unit front panel. Static relay equipment, when supplied in swing rack cabinets, should be securely anchored to the floor or to the shipping pallet to prevent the equipment from tipping over when the swing rack is opened.

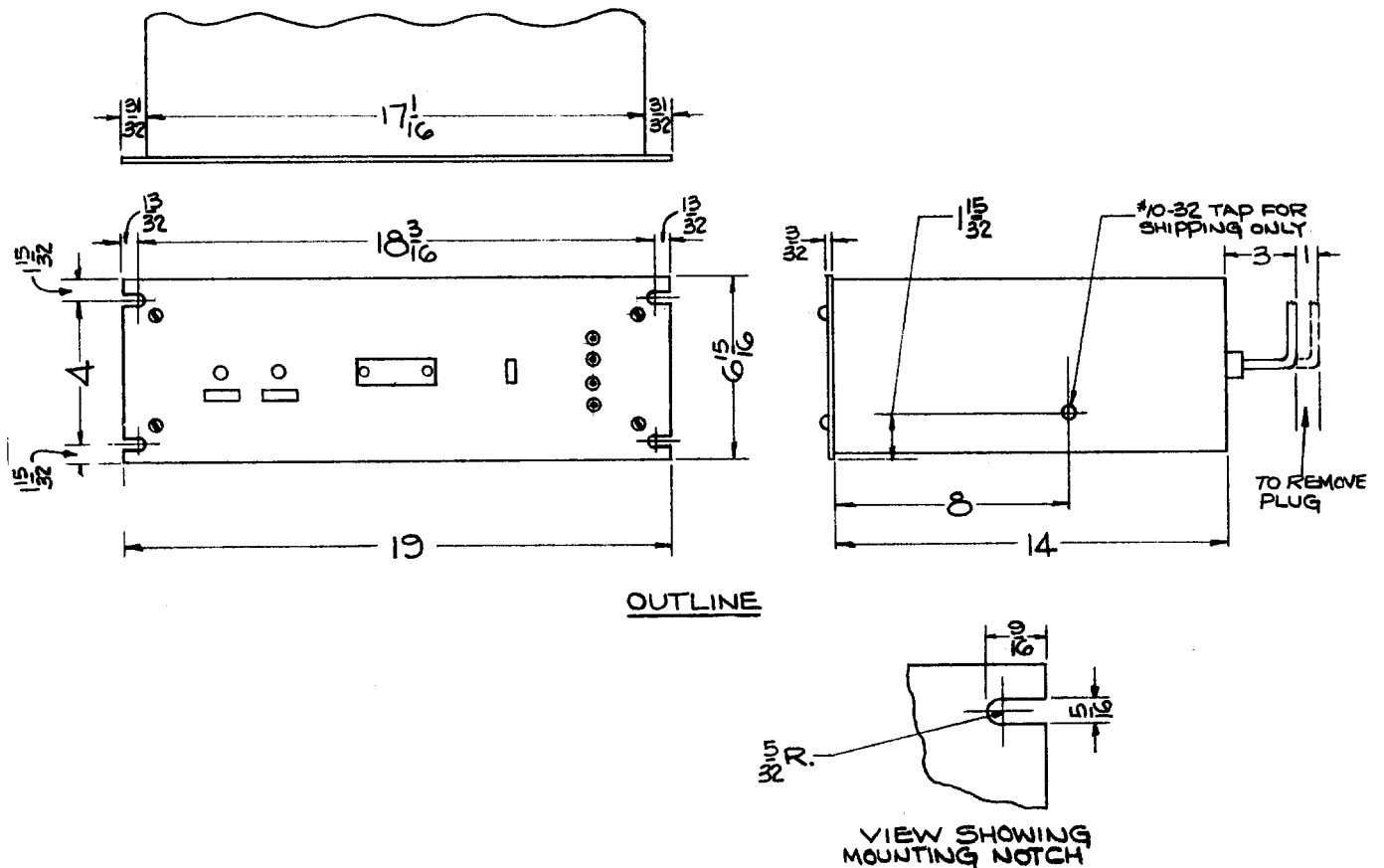

FIG. 1 (0208A3514-0) OUTLINE AND MOUNTING DIMENSIONS FOR THE TYPE SSA51A POWER SUPPLY

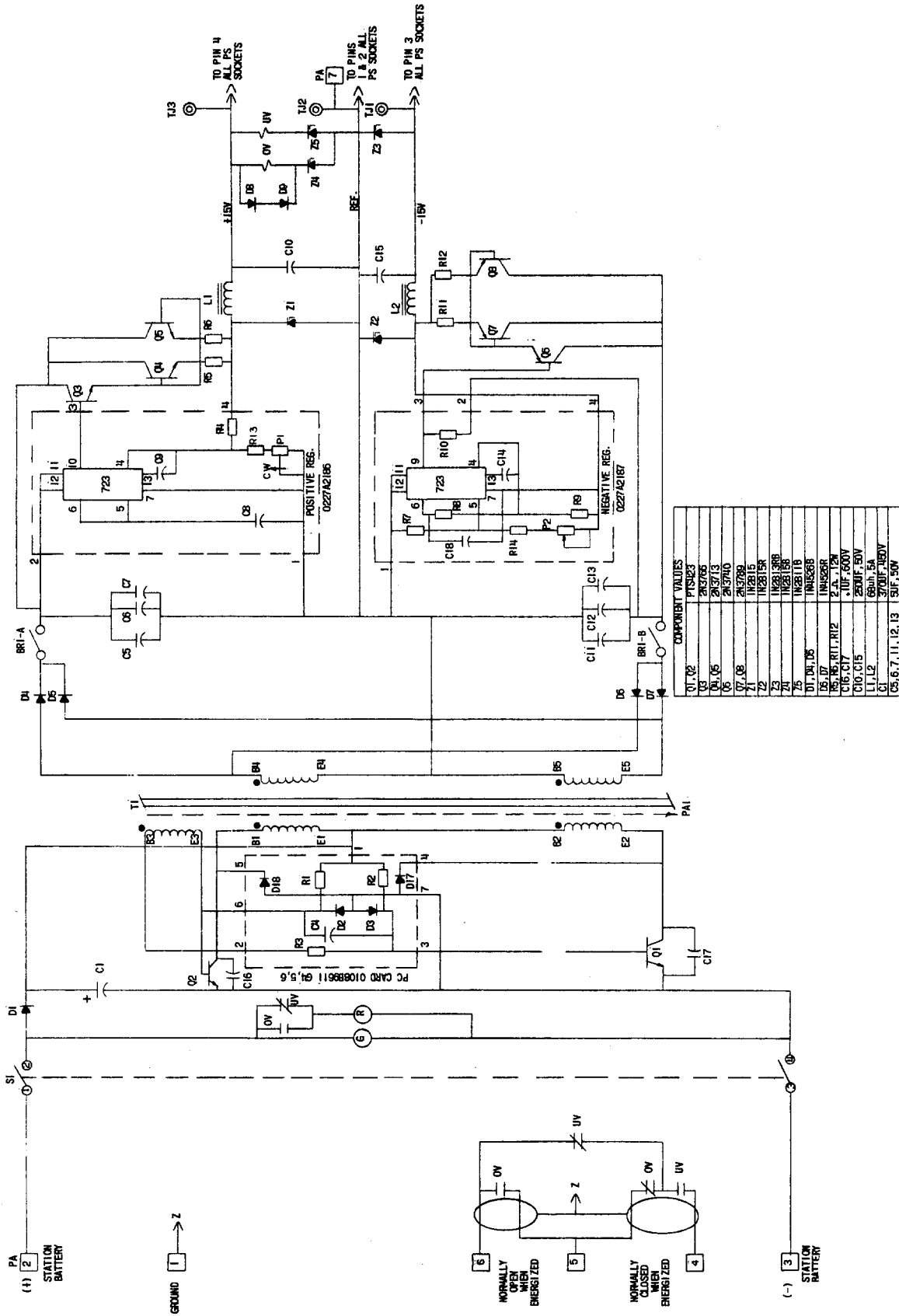
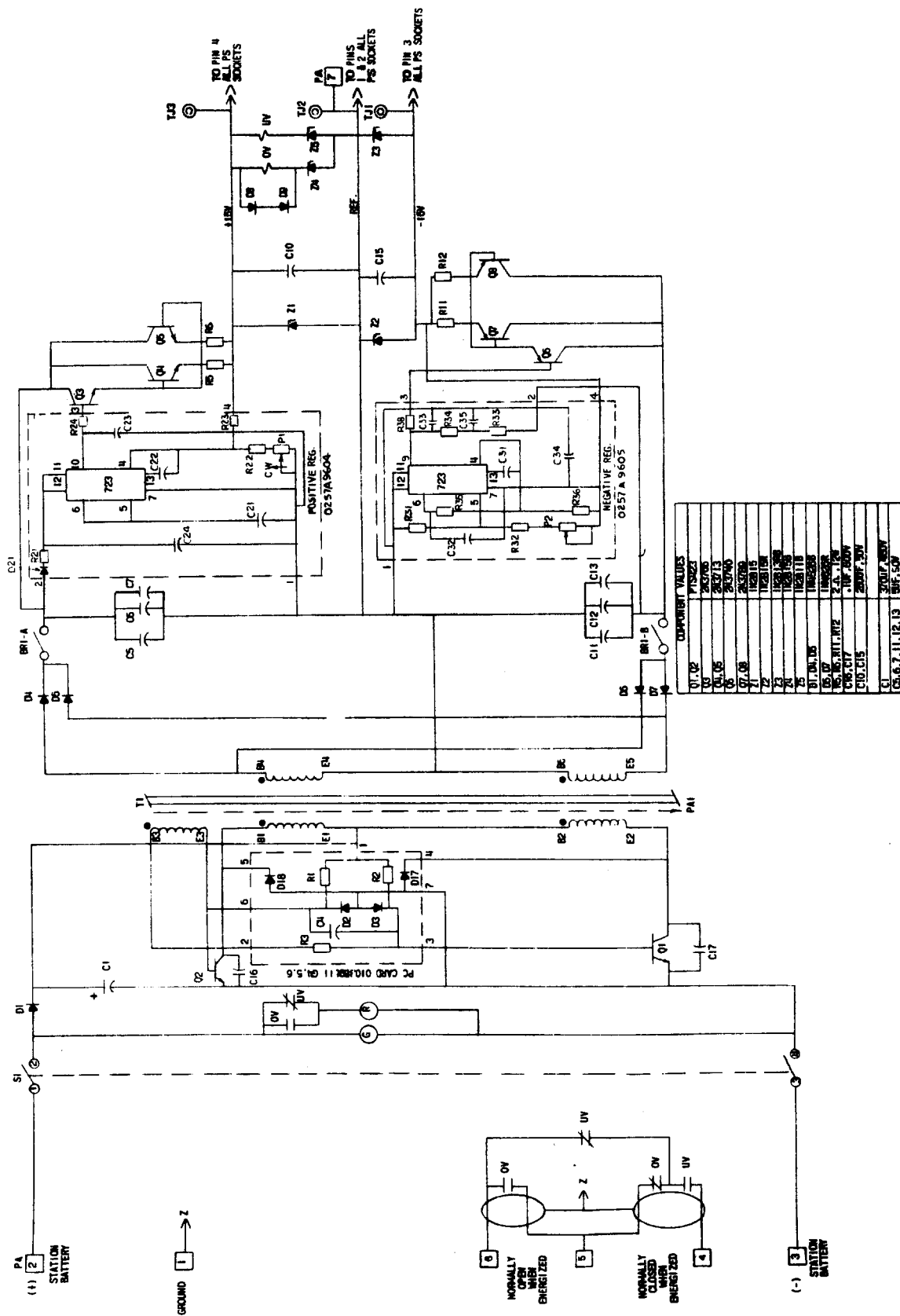

FIG. 2 (0149C7374-0) INTERNAL CONNECTION DIAGRAM FOR THE TYPE SSA51A POWER SUPPLY (FORMS 1,2 and 3)



* FIG. 2A (0171C7820-0) INTERNAL CONNECTION DIAGRAM FOR THE TYPE SSA51A POWER SUPPLY (FORMS 4 and up)

* Indicates Revision

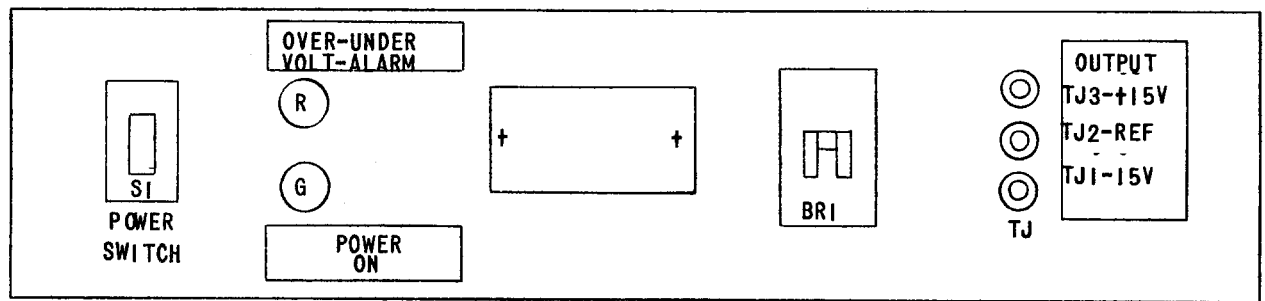
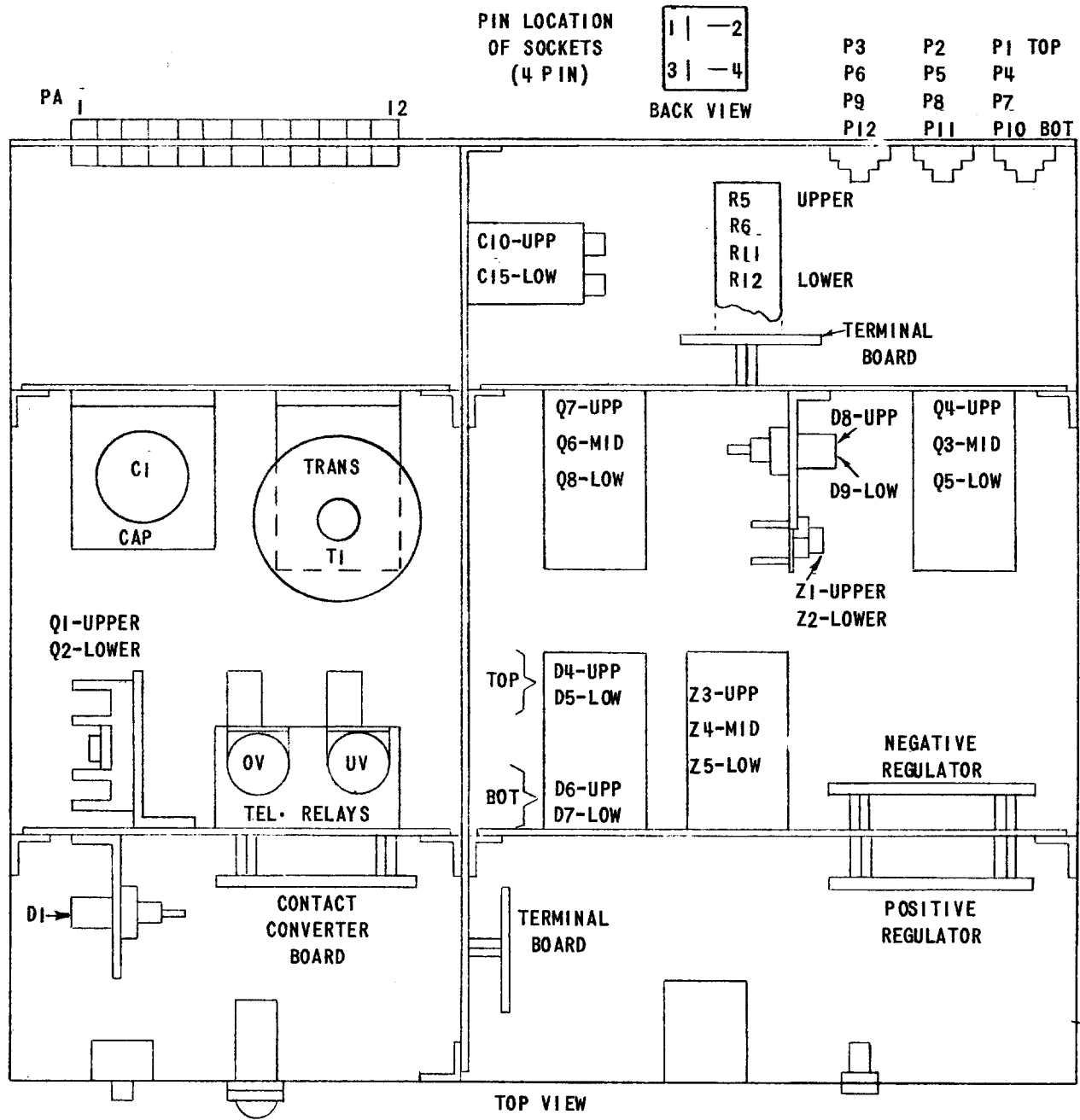
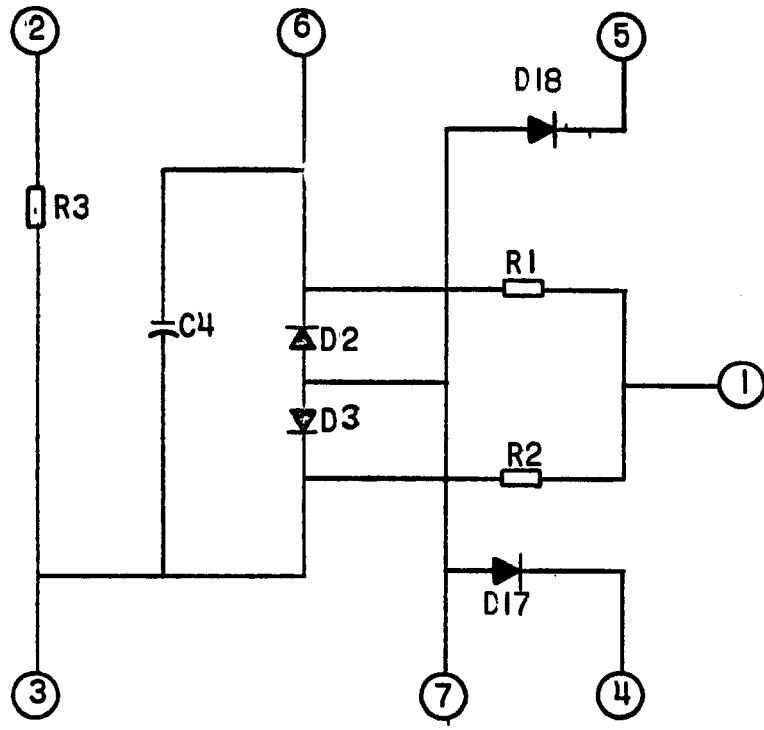

FIG. 3 (0257A6242-0) COMPONENT LOCATION DIAGRAM FOR THE TYPE SSA51A POWER SUPPLY



- $R1, R2 \begin{cases} 6K, 10W-48V \\ 12K, 10W-125V \\ 25K, 10W-250V \end{cases}$
 $R3 \begin{cases} 15\Omega, 5 \frac{1}{4}W - 48V \\ 39\Omega, 2W - 125V, 250V \end{cases}$
 $C4 - .1 \text{ uf}, 50V$
 $D2, D3 - 1N5061$
 $D17, D18$

- P.C. CARD - 0108B9611 G-4 (48V)
 0108B9611 G-5 (125V)
 0108B9611 G-6 (250V)

FIG. 4 (0227A2111-2) INTERNAL CONNECTIONS FOR THE TYPE SSA51A CONVERTER CARD

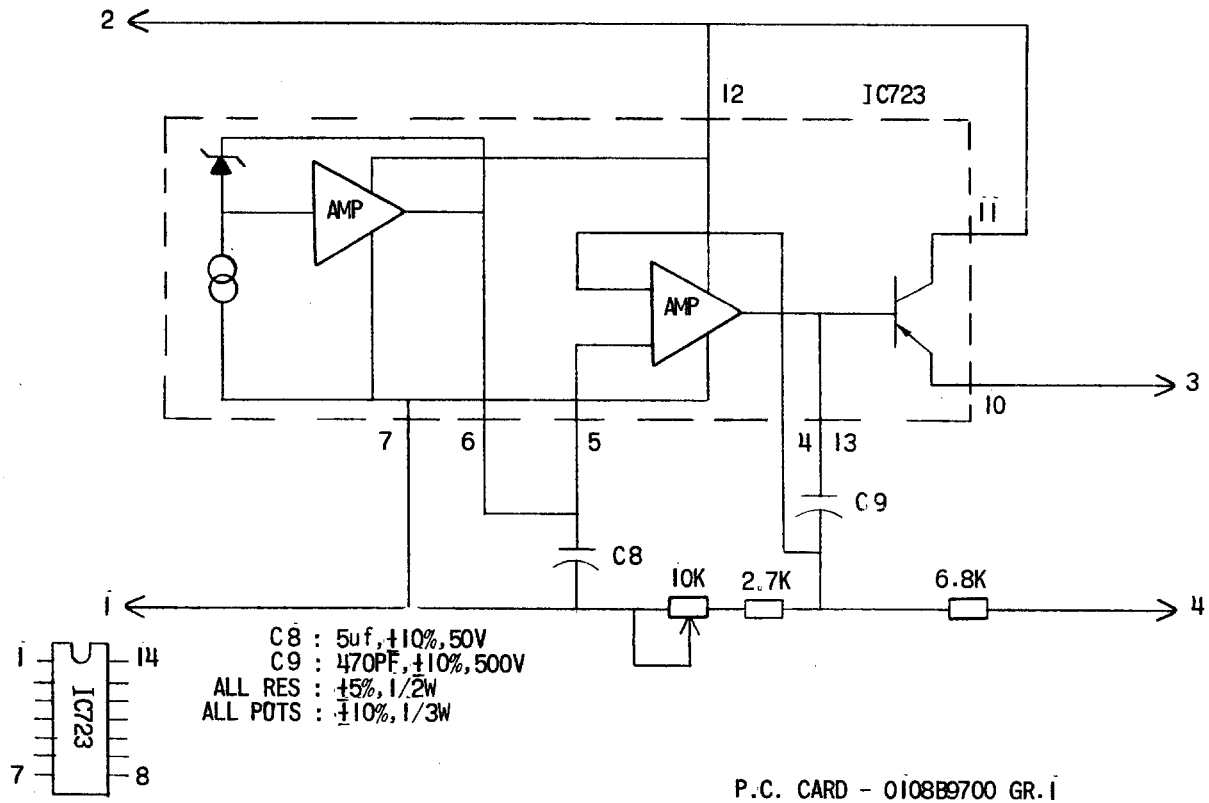
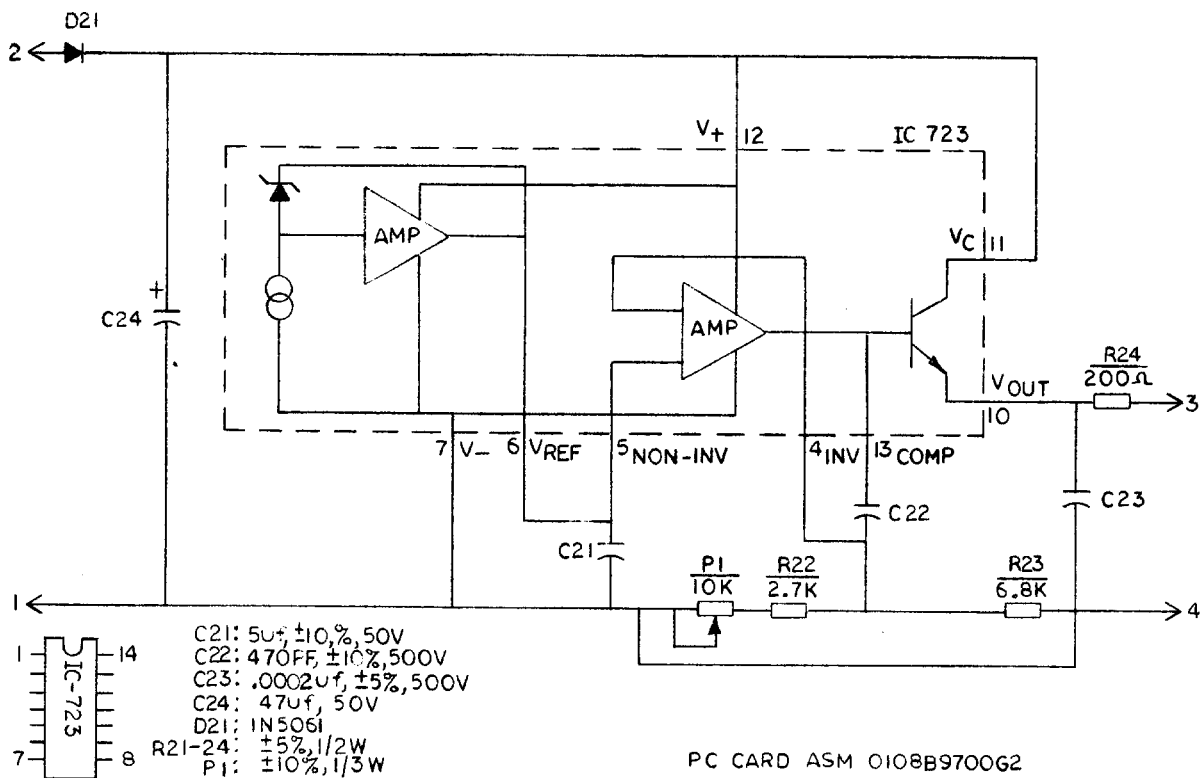

FIG. 5 (0227A2186-0) INTERNAL CONNECTIONS FOR THE POSITIVE REGULATOR CARD (FORMS 1,2 and 3)



* FIG. 5A (0257A9604-1) INTERNAL CONNECTIONS FOR THE POSITIVE REGULATOR CARD (FORMS 4 and up)

* Indicates Revision

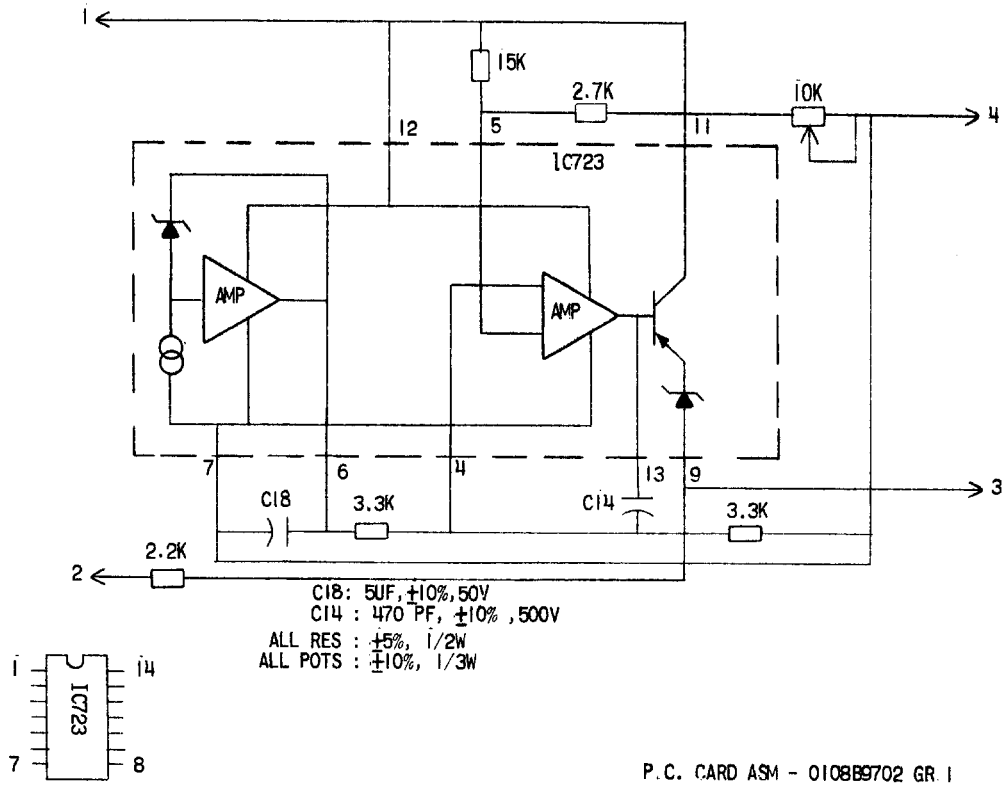
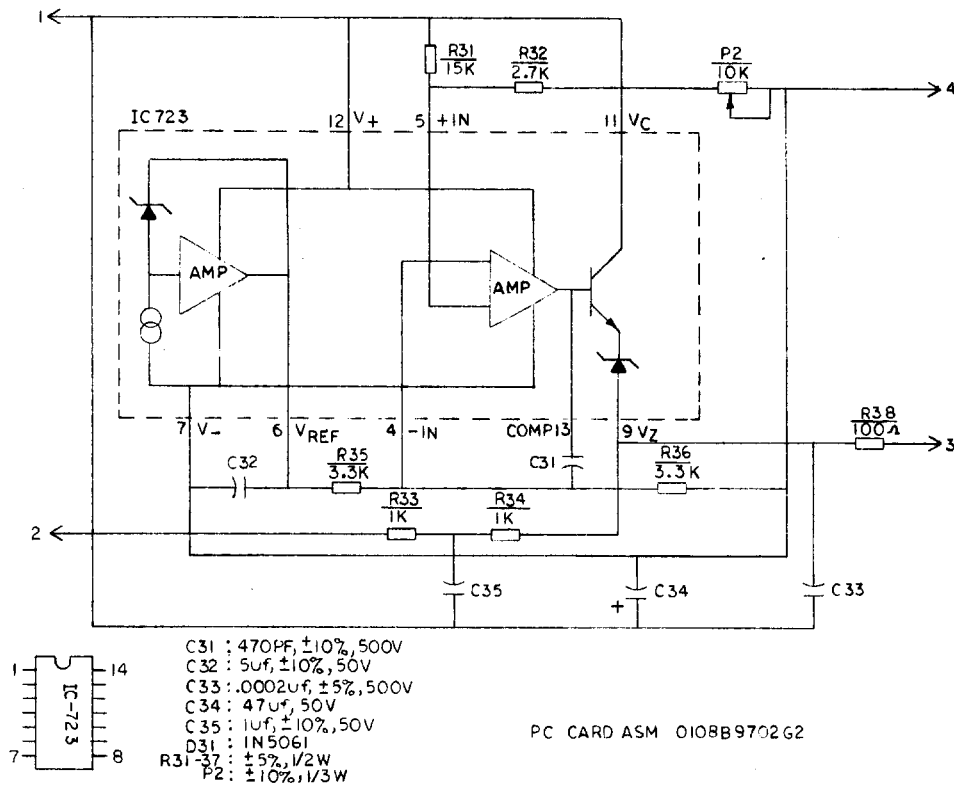

FIG. 6 (0227A2187-0) INTERNAL CONNECTIONS FOR THE NEGATIVE REGULATOR CARD (FORMS 1,2 and 3)



* FIG. 6A (0257A9605-1) INTERNAL CONNECTIONS FOR THE NEGATIVE REGULATOR CARD (FORMS 4 and up)

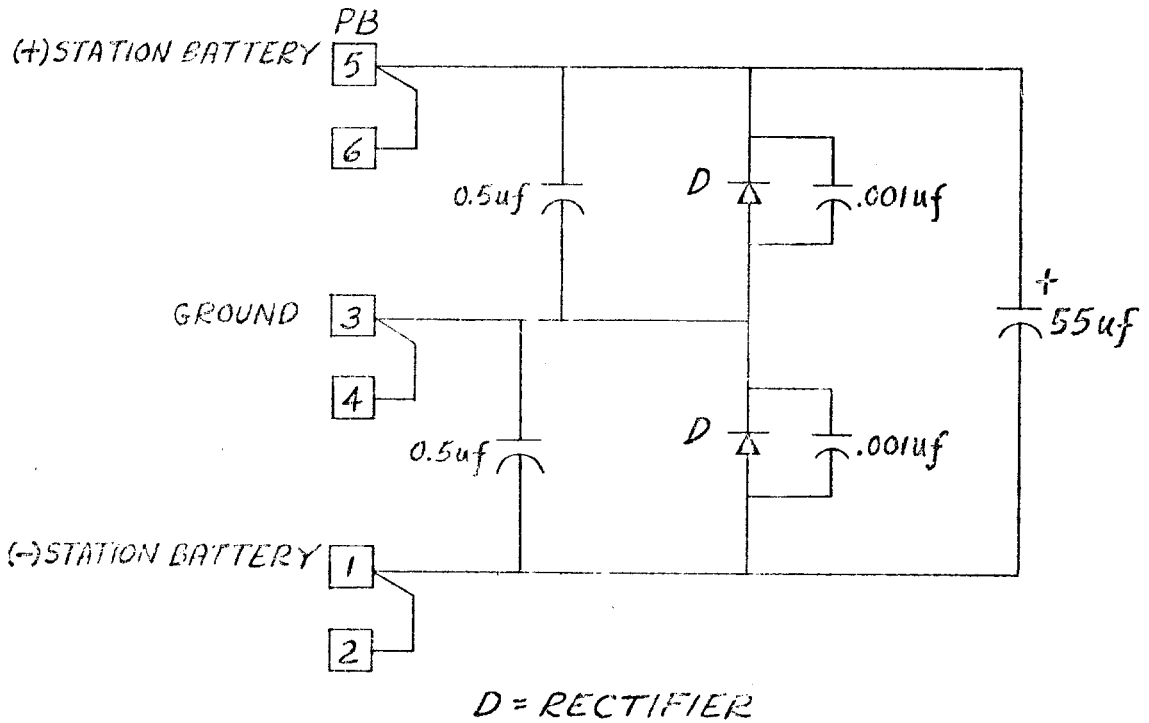

FIG. 7 (0178A9179-1) INTERNAL CONNECTIONS FOR A TYPICAL BATTERY CLAMP

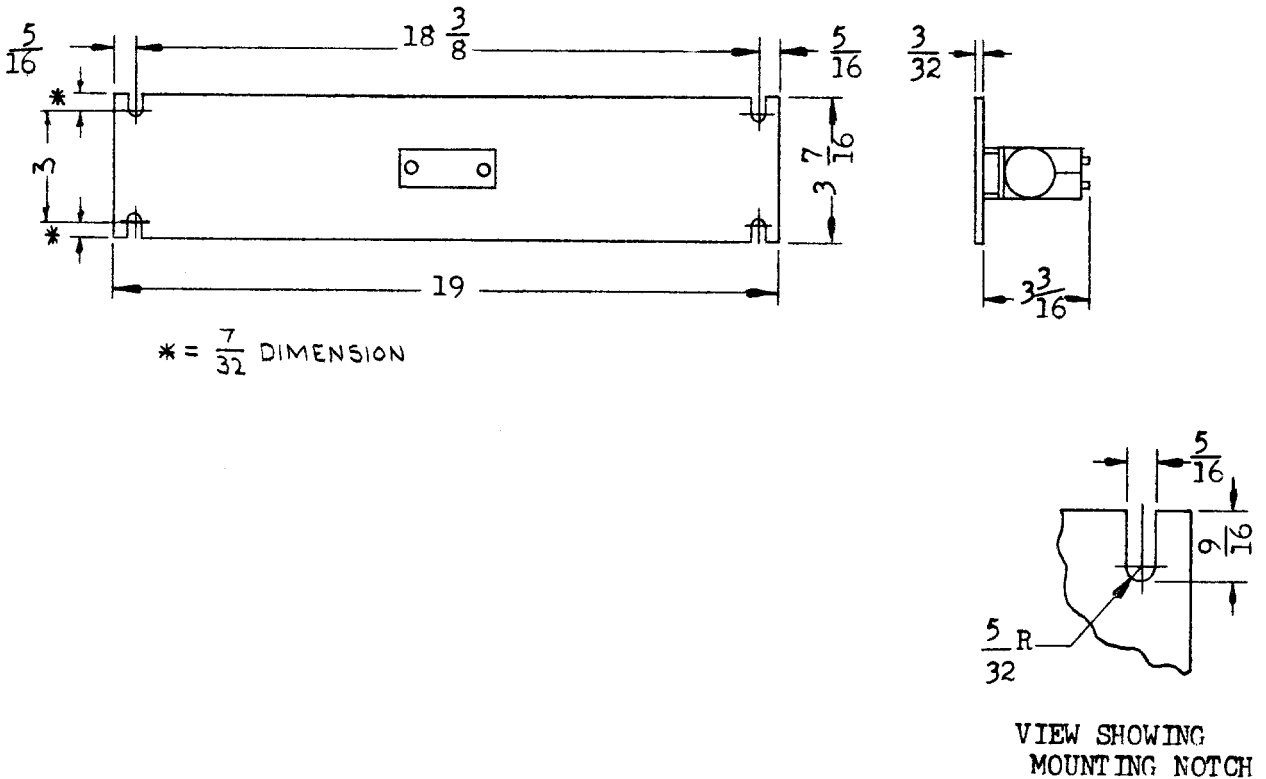
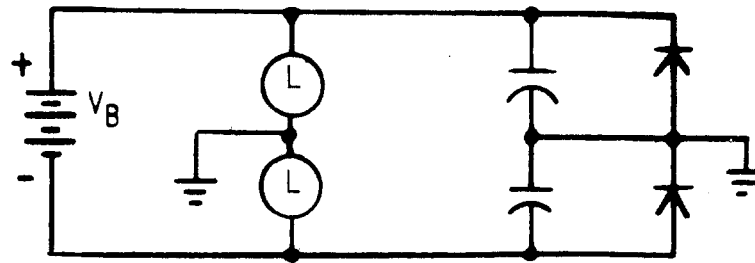
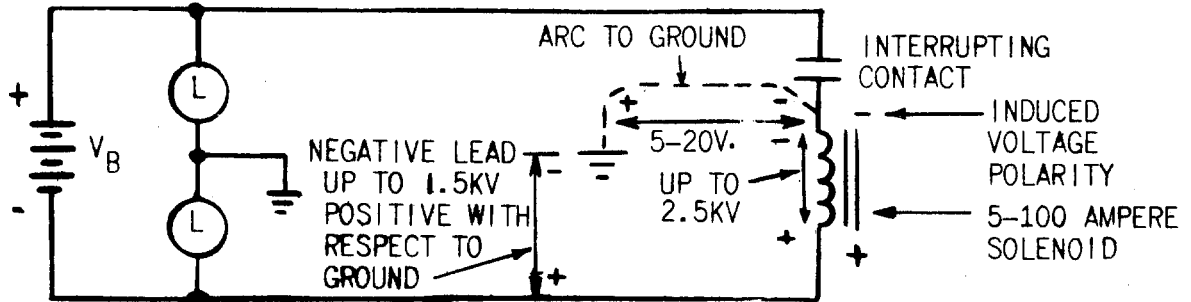

FIG. 8 (0178A9330-1) OUTLINE AND MOUNTING DIMENSIONS FOR A TYPICAL BATTERY CLAMP



(A) NORMAL OPERATING CONDITIONS



(B) ARC-OVER TO GROUND DURING SOLENOID CURRENT INTERRUPTION WITHOUT BATTERY CLAMP RECTIFIERS

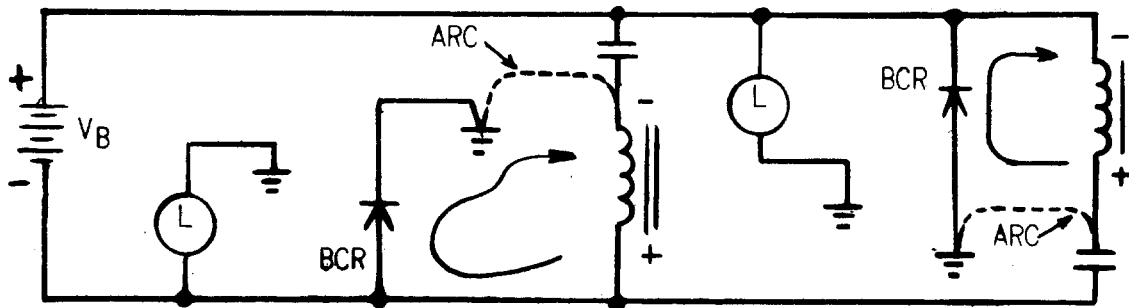

(C) CONDITIONS DURING ARC-OVER TO GROUND WITH BATTERY CLAMP RECTIFIERS (BCR) CONNECTED

FIG. 9 (0148A4062- 1) BATTERY CLAMP SURGE CURRENT CONDITIONS

**GENERAL ELECTRIC COMPANY
POWER SYSTEMS MANAGEMENT BUSINESS DEPT.
MALVERN, PA 19355**

GENERAL  ELECTRIC