



INSTRUCTIONS

GEK-45312A
Insert Booklet GEK-45307

TRANSFORMER DIFFERENTIAL RELAY WITH PERCENTAGE AND HARMONIC RESTRAINT

TYPE STD25D

INTRODUCTION

This instruction book, together with insert booklet GEK-45307, forms the instructions for the Type STD25D relays.

DESCRIPTION AND APPLICATION

The STD25D relay is a single phase harmonic restrained transformer percentage differential relay for the protection of high voltage rectifier transformers. This relay is similar to the STD15C, except that the harmonic restraint is provided by the second harmonic only so that the normal odd harmonic flowing in a rectifier transformer will not reduce the relay sensitivity. This harmonic selection is accomplished by finely tuned filters. However, the change in harmonic restraint does not change the application or setting calculation as outlined for the STD15, except that the STD25D relay is so designed that the harmonic restraint may be set at 15 percent minimum.

Figure 1 illustrates the internal connections diagram for the Type STD25D relay.

Figure 2 illustrates the external wiring diagram for the Type STD25D relay.

Figure 3 illustrates the test circuit for the Type STD25D relay. Note polarity when connecting DC sources.

TESTING INSTRUCTIONS

*
* The STD25D relay may be tested per the instructions in the attached instruction book. In addition, since the harmonic restraint can be set at 15 percent by adjusting R2, such may be checked by adjusting the I_{dc} at 4.0 amps and the I_1 (current into relay) at 8.1 amps, per the test circuit illustrated in Figure 3A with the S2 switch closed to position "A."

These instructions do not purport to cover all details or variations in equipment nor to provide for every possible contingency to be met in connection with installation, operation or maintenance. Should further information be desired or should particular problems arise which are not covered sufficiently for the purchaser's purposes, the matter should be referred to the General Electric Company.

To the extent required the products described herein meet applicable ANSI, IEEE and NEMA standards; but no such assurance is given with respect to local codes and ordinances because they vary greatly.

*Indicates Revision

GEK-45312

A tolerance of plus or minus one percent is acceptable, thus if the relay operated within 14-16 percent harmonic restraint for the 15 percent calibration, no attempt should be made to obtain a more precise setting.

The following expression shows the relationship between the percent second harmonic, the dc component and the bypass current:

$$\text{Percent Second Harmonic} = \frac{0.212 I_{dc}}{0.45 I_1 + 0.5 I_{dc}} \times 100$$

By setting the I_{dc} at 4.0 amps, and solving for the "percent second harmonic" for 14-16%, the following bypass current levels are required:

PERCENT HARMONIC RESTRAINT	I_1
14	9.1

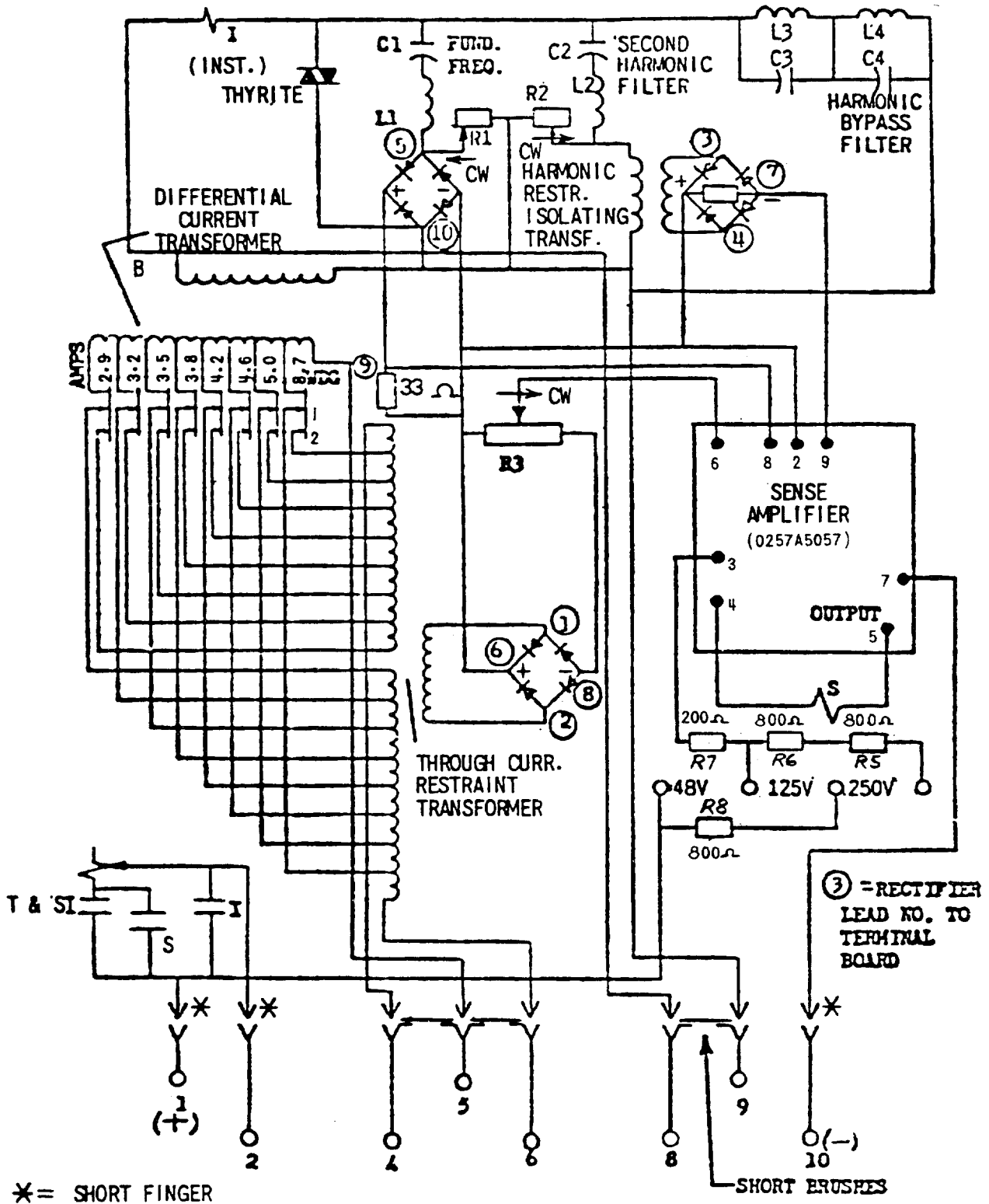

Figure 1 (0257A5031-0) Internal Connections Diagram for the Type STD25D Relay (Front View)

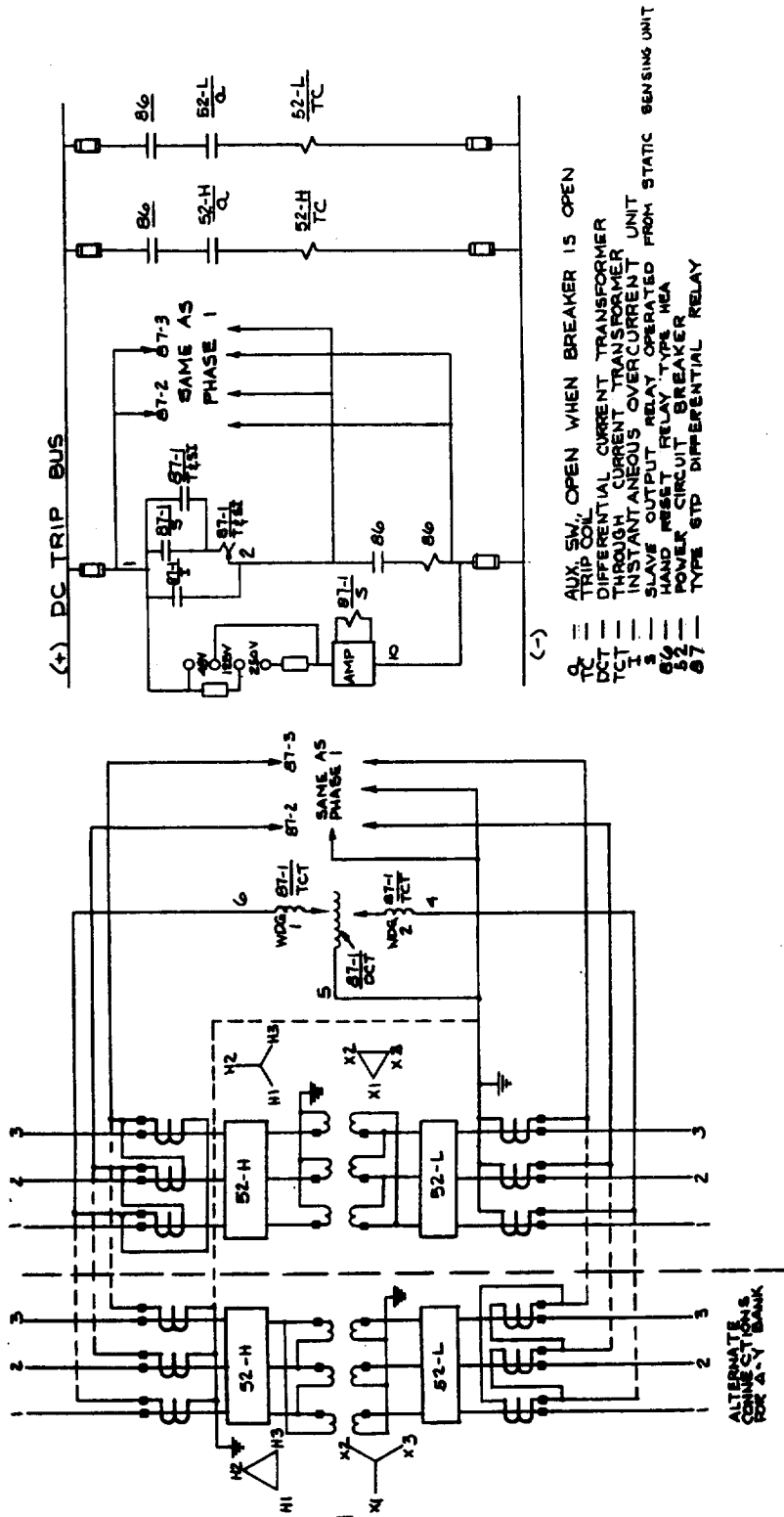
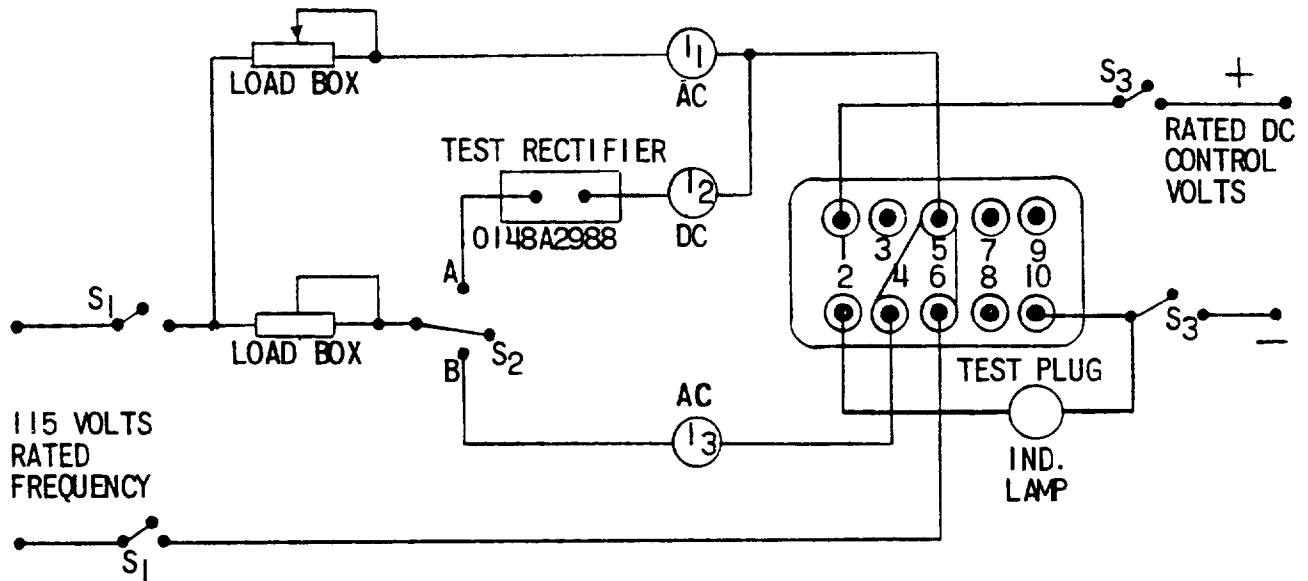
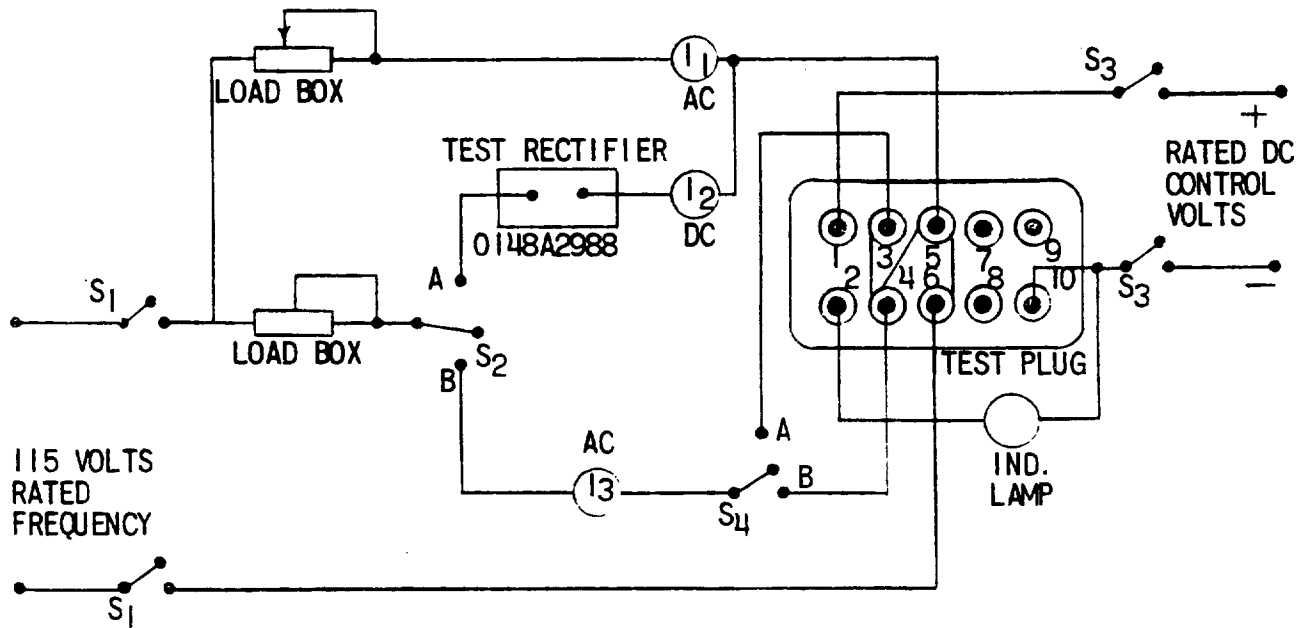

Figure 2 (0128B1981-1) External Wiring Diagram for the Type STD25D Relay



A. TEST CIRCUIT FOR STD25D OR 25E RELAYS
(FOR STD 25E REVERSE POLARITY OF 1 & 10)



B. TEST CIRCUIT FOR STD26C RELAYS

Figure 3 (0227A2567-2) Test Connections Diagram
for the Type STD25 Relays

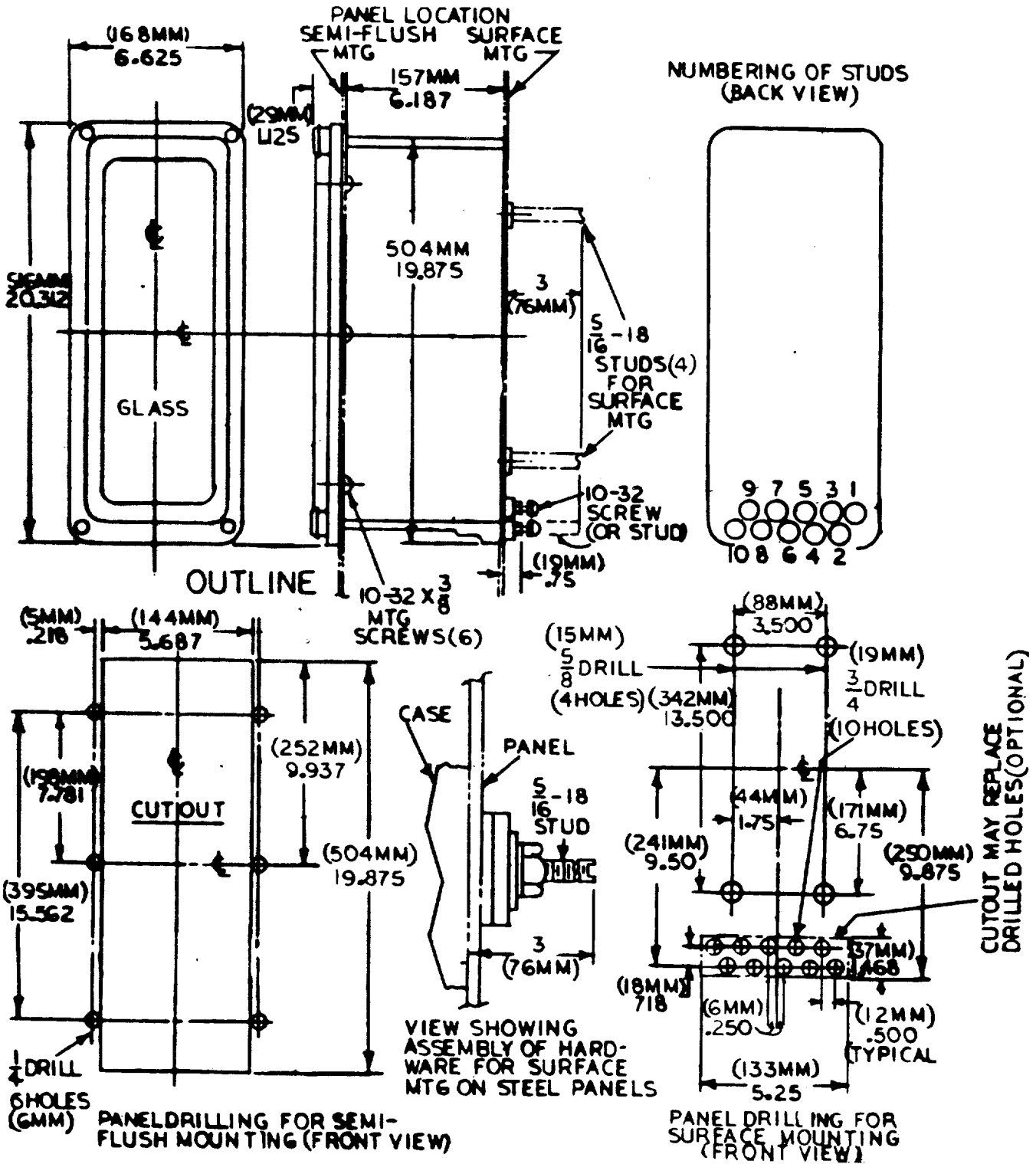

Figure 4 (K-6209275-1) Outline and Panel Drilling Dimensions for the Type STD25 Relays



GE Power Management

**215 Anderson Avenue
Markham, Ontario
Canada L6E 1B3
Tel: (905) 294-6222
Fax: (905) 201-2098
www.ge.com/indsys/pm**