



# INSTRUCTIONS

---

## TLS 1114 MODULAR RELAY SYSTEM FOR TRANSMISSION LINE PROTECTION

### INTRODUCTION

This instruction book, together with insert booklet GEK-86638B, forms the instructions for the TLS 1114 Relay.

### DESCRIPTION

The TLS 1114 is similar to the TLS 1109, which incorporates three (3) separate zones of protection. The feature that makes the two different lies in the DLA point locations. These distinguishing features are evident in the elementary diagrams, Figures 1, 2, 3, 4, and 5 of this insert book.

*These instructions do not purport to cover all details or variations in equipment nor to provide for every possible contingency to be met in connection with installation, operation or maintenance. Should further information be desired or should particular problems arise which are not covered sufficiently for the purchaser's purposes, the matter should be referred to the General Electric Company.*

*To the extent required the products described herein meet applicable ANSI, IEEE and NEMA standards; but no such assurance is given with respect to local codes and ordinances because they vary greatly.*

LIST OF FIGURES

FIGURE	DRAWING #	DESCRIPTION
1	0184B5787 Sh.1	Elementary for TLS 1114
2	0184B5787 Sh.2	Elementary for TLS 1114
3	0184B5787 Sh.3	Elementary for TLS 1114
4	0184B5787 Sh.4	Elementary for TLS 1114
5	0184B5787 Sh.5	Elementary for TLS 1114

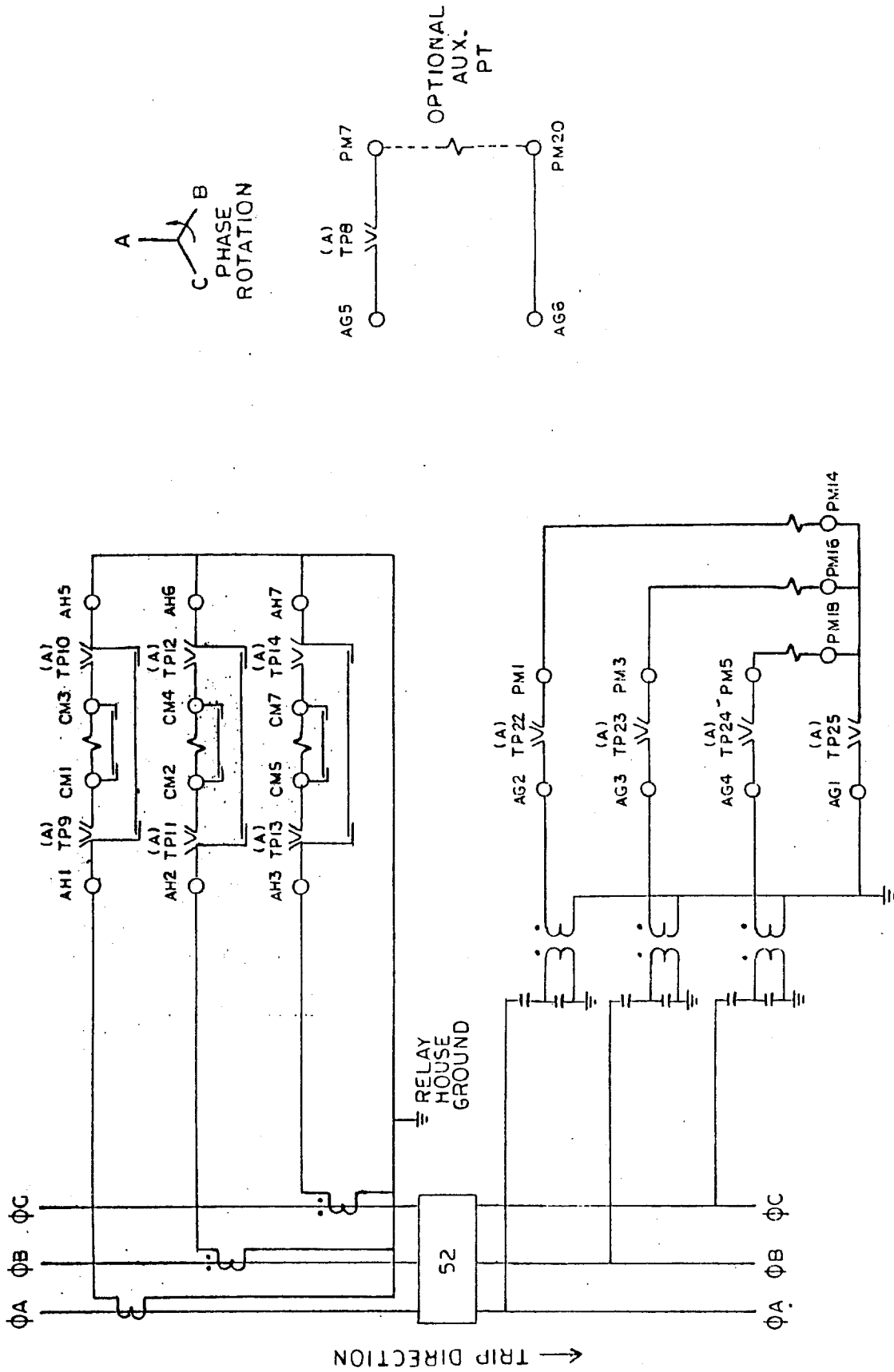

Figure 1 (0184B5787 Sh.1) Elementary for TLS 1114

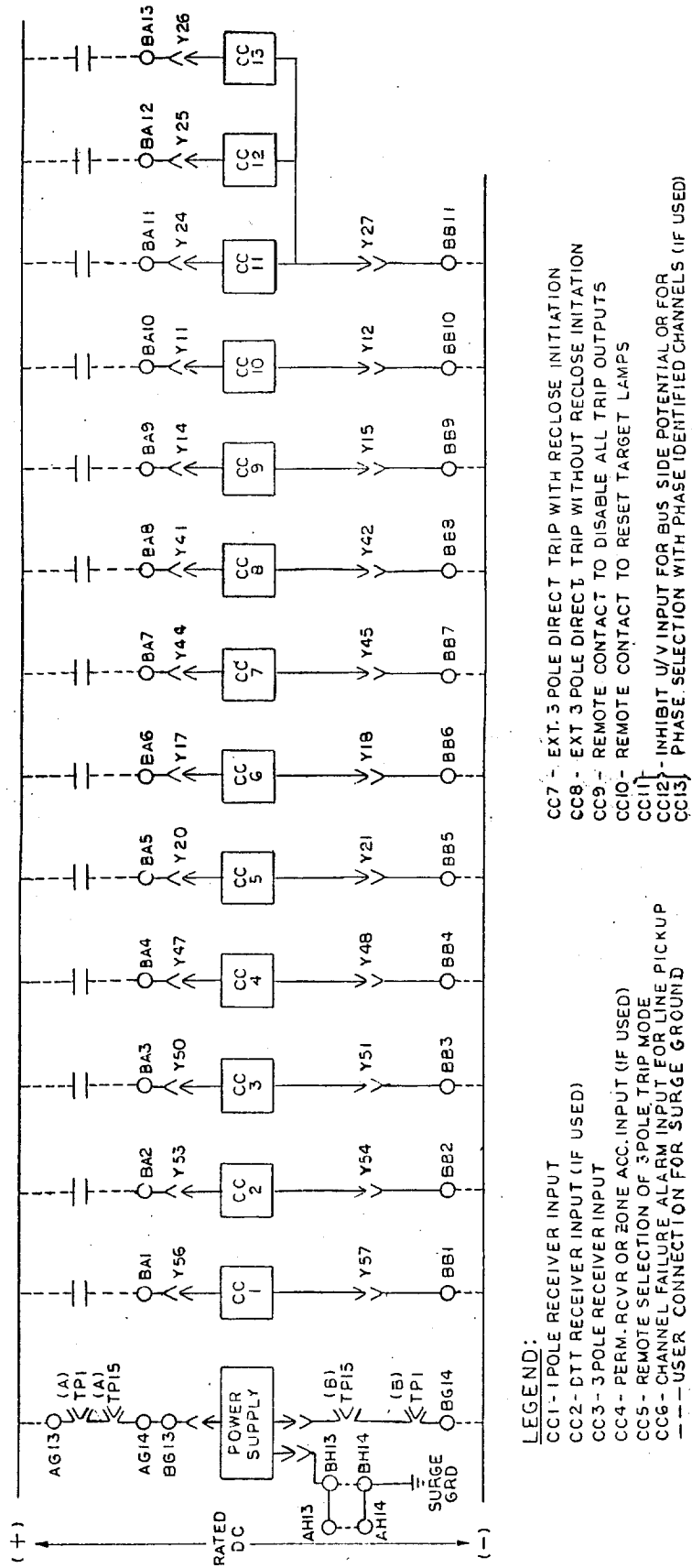

Figure 2 (0184B5787 Sh.2) Elementary for TLS 1114

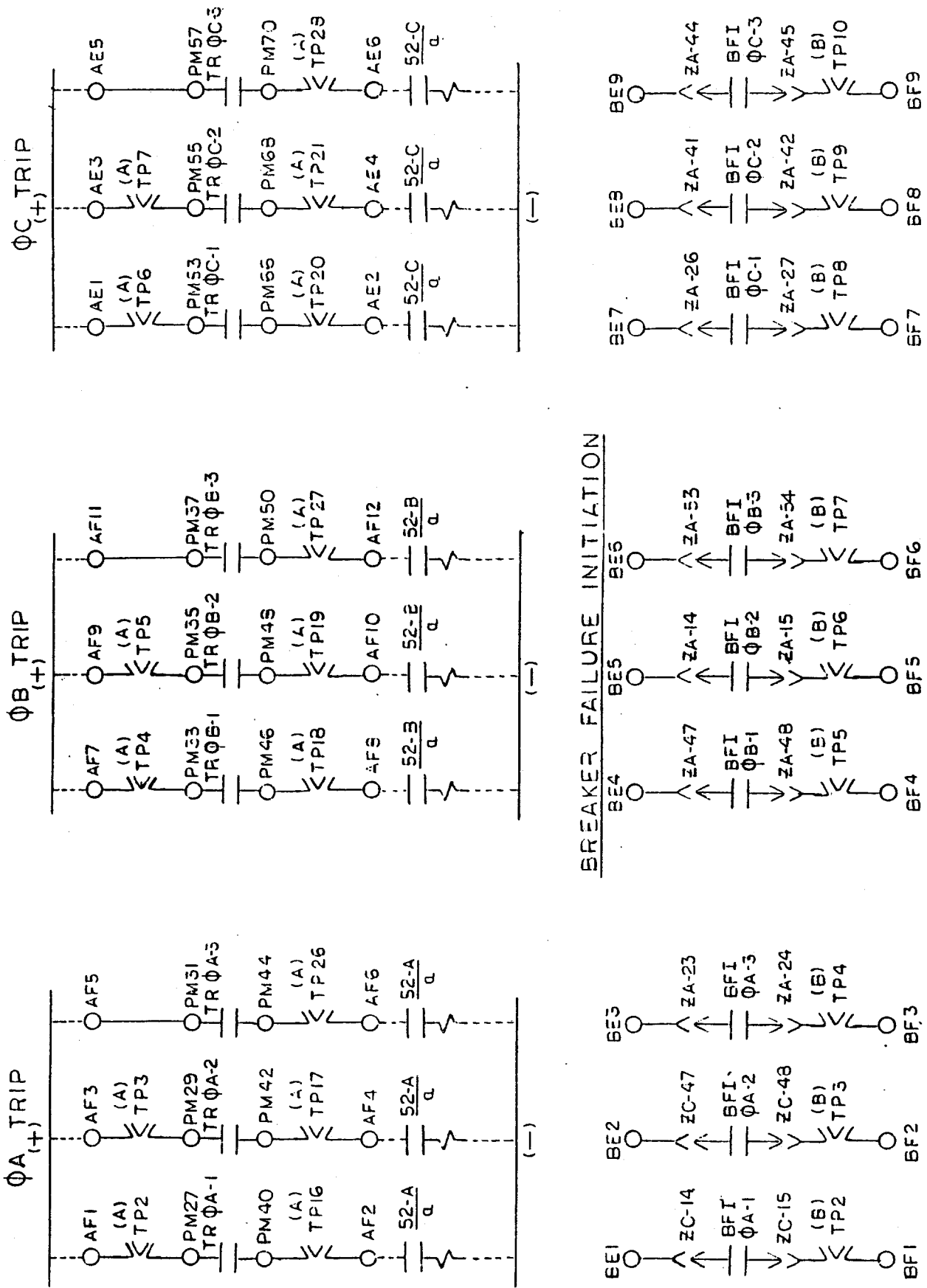

Figure 3 (0184B5787 Sh.3) Elementary for TLS 1114

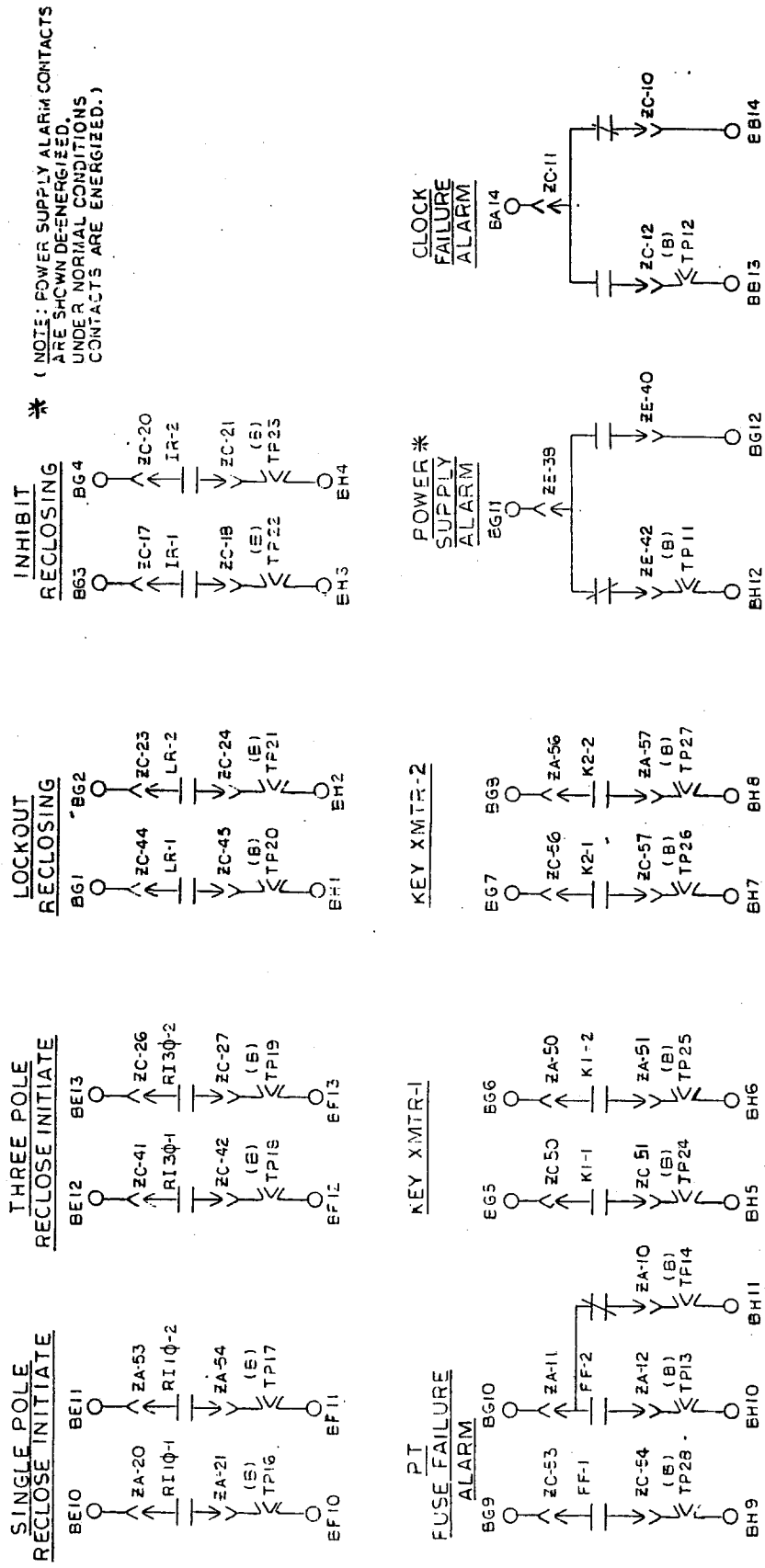
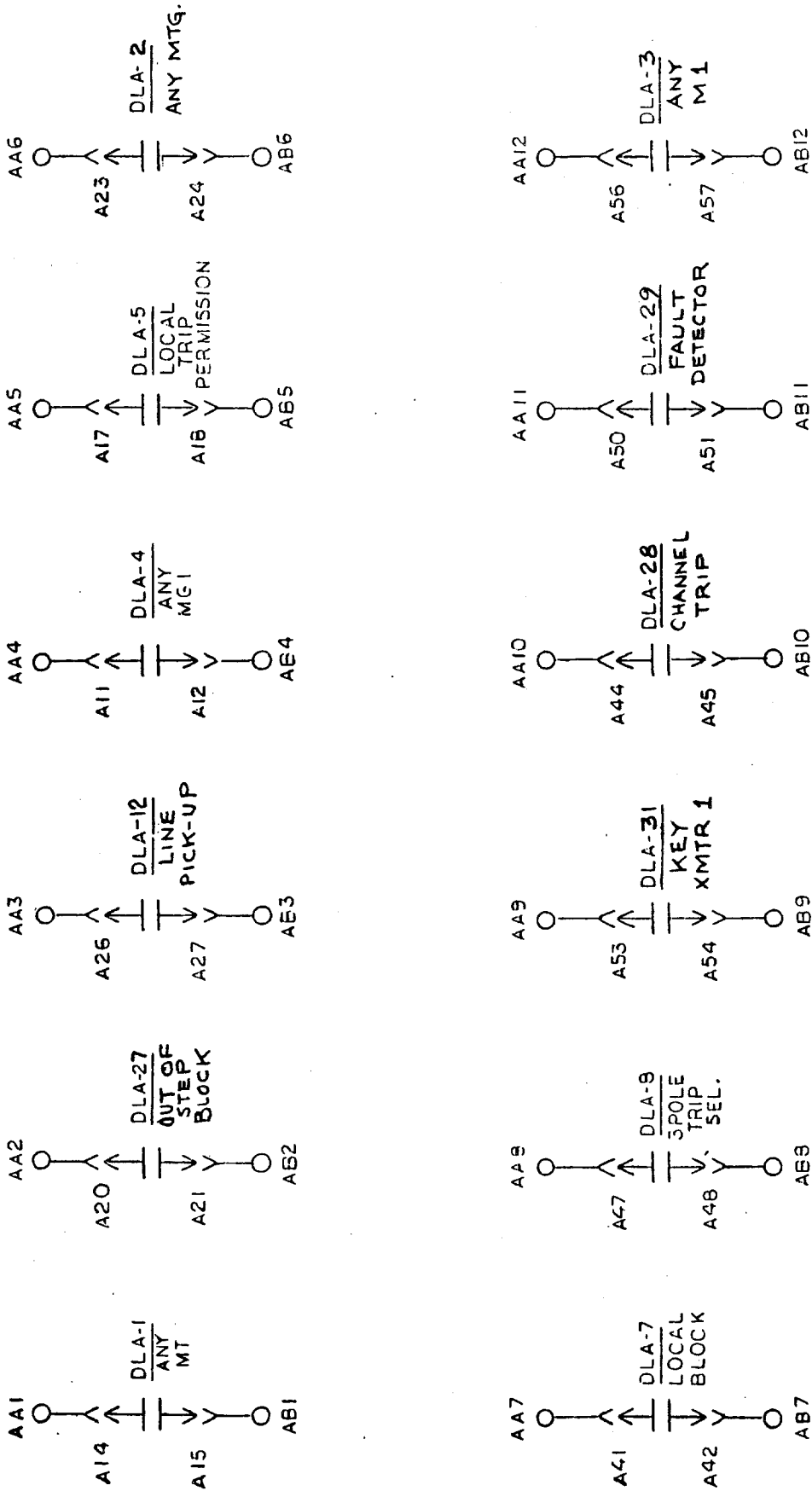

Figure 4 (0184B5787 Sh.4) Elementary for TLS 1114



DLA CONTACTS

Figure 5 (0184B5787 Sh.5) Elementary for TLS 1114

***Meter and Control  
Business Department***

---

(6/91) (200)

General Electric Company  
Protection and Control  
205 Great Valley Parkway  
Malvern, Pennsylvania 19355-0715