

For Field Testing  
MicroVersaTrip®  
Solid-state  
Programmable



# MicroVersaTrip® Test Set

Type TVTS1

*File copy*





# Table of Contents

Contents	Page
INTRODUCTION .....	3
Testing the Solid-state Programmer Only—Mode "1" ...	3
Testing the Complete Trip System—Mode "2" .....	3
APPLICABLE TIME—CURRENT CURVES .....	3
SPECIFICATIONS .....	3
OPERATING CONTROLS .....	4
On-Off Switch .....	4
Trip Breaker—Programmer Only Switch .....	4
Preset Current Button .....	4
Start Button .....	4
Reset Button .....	4
Trip Light .....	4
Programmer Type Switch .....	4
Programmer Current Setting Switch .....	4
Test Selector Switch .....	4
Component Test Selector Switch .....	5
Sequence Switch .....	5
Push to Test Button .....	5
Elapsed Time Meter .....	5
Test Current Meter .....	5
Output Jacks J1 and J2 .....	5
External Monitor—Test Set Accuracy .....	5
HOW TO REMOVE THE SOLID-STATE PROGRAMMER	
FOR TESTING .....	5
CONNECTING THE TEST SET .....	6
Safety Precautions .....	6
Connections .....	6
Programmer Only Test—Mode "1" .....	6
Complete System Test—Mode "2" .....	7
PRELIMINARY TEST PROCEDURE .....	8
FUNCTIONAL TESTS .....	8
Long Time Pickup Test .....	8
Long Time Delay Test .....	9
Short Time Delay Test .....	10
Short Time Pickup Test .....	12
Instantaneous Pickup Test—Standard .....	13
Instantaneous Pickup Test—High Level .....	14
Ground Fault Pickup Test .....	15
Ground Fault Delay Test .....	16
Ground Fault Continuity Test .....	17
Converter Check Test .....	18
COMPONENT TESTS .....	19
Zone Interlock Transmit Test .....	19
Short Time Transmit Test .....	19
Ground Fault Transmit Test .....	19
Open Diode Test .....	19
Shorted Diode Test .....	19
Sensor Continuity Test .....	19
FAULT TRIP ANNUNCIATORS .....	20
HOW TO USE THE "EXTERNAL MONITOR" .....	20
IF RESULTS DO NOT CONFORM .....	21
COMPLETION OF TESTS .....	21
RECORD OF ORIGINAL "IN SERVICE"	
PROGRAMMER SETTINGS AND NOTES .....	22
SCHEMATIC DIAGRAM .....	23

These instructions do not purport to cover all details or variations in equipment nor do they provide for every possible contingency to be met in connection with installation, operation or maintenance. Should further information be desired, or should particular problems arise which are not covered sufficiently for the purchaser's purpose, the matter should be referred to the General Electric Company.



# Introduction

The Type TVTS1 Test Set is a portable instrument designed for the field testing of MicroVersaTrip® solid-state programmers. The complete trip system is comprised of the following components:

1. Solid-state programmer
2. Phase Current Sensors
3. Flux Shift Magnetic Trip Device
4. When applicable, a Neutral Sensor for units containing a Ground Fault trip element.

All components, except the Neutral Sensor, are integrally mounted in the circuit breaker. When used, the Neutral Sensor is separately mounted in the bus or cable compartment of the switchgear. In drawout construction, it is automatically connected to the programmer in the breaker via a drawout secondary disconnect block.

Two basic types of solid-state programmers will be tested. See Fig. 1.

The Test Set is used to perform various programmer tests in two basic modes:

Testing the Solid-state Programmer Only—Mode "1"

Testing the Complete Trip System—Mode "2"

**WARNING: THESE TESTS CAN BE CONDUCTED ONLY ON A DE-ENERGIZED BREAKER—ONE WHICH IS COMPLETELY DISCONNECTED FROM ITS PRIMARY AND CONTROL POWER SOURCES.**

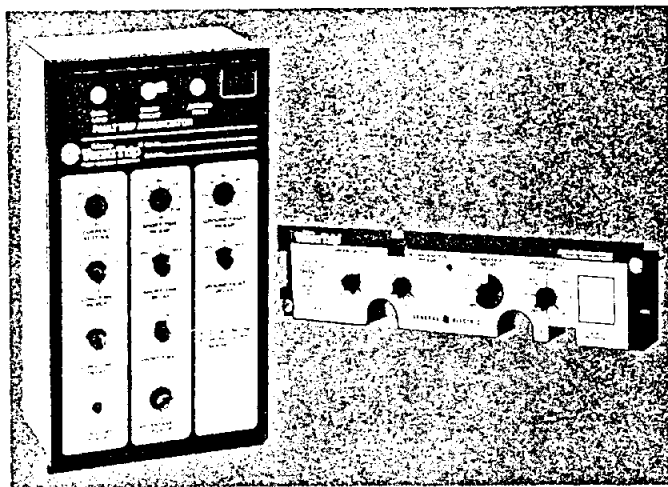

MicroVersaTrip®  
TP4VT, TP9VT,  
TAVT programmers

MicroVersaTrip®  
T4VT programmer

Fig. 1

## Testing the Solid-state Programmer Only—Mode "1"

A test mode is used where only the solid-state programmer is tested, and is particularly useful in testing spare or alternate programmers.

It should be noted however, that there can be no substitute for complete testing of the trip system per Mode "2". See Fig. 5. Since the programmer is only a part of the complete trip system, the *PROGRAMMER ONLY* tests should be recognized as only a partial system test.

### Test Scope

1. Verify the time-current characteristics and pickup calibration of the various trip elements.

Designations for the trip elements are abbreviated as follows:

LT—LONG TIME                      ST—SHORT TIME  
INST.—INSTANTANEOUS      GF—GROUND FAULT

2. Verify performance of the ZONE SELECTIVE INTER-LOCKING functions on programmers so equipped.
3. Verify the integrity of key electronic components in the solid-state programmer.
4. Verify operation of the Fault Trip annunciators on programmers so equipped.

## Testing the Complete Trip System—Mode "2"

For these tests, the programmer is connected to the breaker through the test set.

### Test Scope

1. All programmer tests previously described, plus the provision to optionally switch the programmer's output to activate the Flux Shift Magnetic Trip Device to verify its operation by physically tripping the breaker.
2. Check continuity of the Phase Sensors.

## Applicable Time-current Curves

- GES 6198—Four-function (T4VT; TP4VT)  
MicroVersaTrip® : LT; ST; INST.
- GES 6199—Full-function MicroVersaTrip® : LT; ST; INST.
- GES 6195—Ground Fault

## Specifications

- Input: 105-125 Vac, 50/60 Hz
- Power Consumption: 60 Watts
- Weight: 30 Pounds
- Overall Dimensions (Inches): 22 $\frac{3}{8}$  L x 12 $\frac{3}{8}$  W x 9 $\frac{3}{8}$  H.



# Operating Controls (See Fig. 2)

## ON-OFF Switch

This switch applies 115-Vac input power to the test set when the switch is ON. Protection is provided by a one-ampere fuse located above the ON-OFF switch.

## TRIP BREAKER—PROGRAMMER ONLY Switch

- PROGRAMMER ONLY Position

The programmer's trip signal is confined to the test set circuitry and cannot trip the breaker.

- TRIP BREAKER Position

The programmer's trip signal is directed to the circuit breaker's magnetic trip device to physically trip the breaker. This mode establishes the integrity of the magnetic trip device and the programmer's ability to actuate it.

## PRESET CURRENT Button

This button enables the operator to pre-establish (via the TEST CURRENT ADJUST control) the desired test current prior to initiating a test.

## START Button

This button initiates the test by applying current to the programmer. The current persists until the unit trips or the RESET button is actuated.

## RESET Button

This button resets the test set logic so that a new test sequence can be initiated. It also stops a test in progress.

## TRIP Light

This LED, when lit, indicates that a trip signal has been delivered by the programmer. A trip indication will always be accompanied by a brief audio tone.

## PROGRAMMER TYPE Switch

This switch is to be positioned according to the programmer type which is normally determined from the programmer Cat. No. If there is any question as to whether the programmer is Type A or B, it can be answered by running the CONVERTER CHECK. (See page 18).

## PROGRAMMER CURRENT SETTING Switch

This control establishes a test current magnitude consistent with and specifically for each CURRENT SETTING of the programmer. The position of this control *must* match the setting on the programmer when testing the LT and ST elements.

## TEST SELECTOR Switch

This selector is to be positioned according to the type of test to be run. Associated with the TEST SELECTOR is a grouping of toggle switches and a rotary switch which further break down the major tests into specific test options.

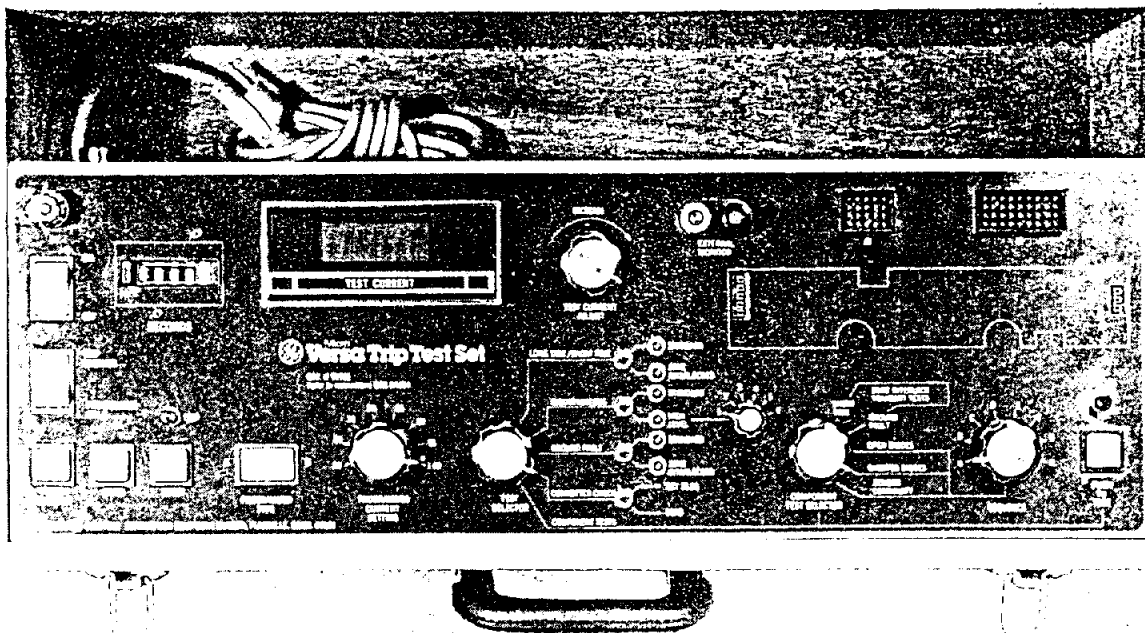

Fig. 2. Front panel





## Operating Controls (See Fig. 2)

### COMPONENT TEST SELECTOR Switch

This switch becomes active when the TEST SELECTOR is in the COMPONENT TESTS position. The switch selects one of several auxiliary tests that are necessary for complete testing of the programmer.

### SEQUENCE Switch

This switch directs the test signals to various points in the programmer circuitry.

### PUSH TO TEST Button

A push button switch which initiates each of the component tests, resulting in illumination of the "OK" LED indicator when a satisfactory test result is achieved. Failure of the "OK" indicator to light signifies an unsatisfactory test result.

### ELAPSED TIME Meter

This meter is a counter which records the programmer's trip time in seconds and tenths. It must be manually reset after completion of each test. The accuracy of the timer is one digit  $\pm 0.1$  second.

**NOTE:** When operating the test set from a 50-Hz supply, readings of the ELAPSED TIME meter must be multiplied by 1.2.

### TEST CURRENT Meter

This meter provides digital readout of the magnitude of the test current being applied to the programmer.

### TEST CURRENT ADJUST

This device is a high-resolution ten-turn potentiometer used to vary the TEST CURRENT applied to the programmer.

### Output Jacks J1 & J2

Jack J1 connects to the circuit breaker via the circuit breaker INTERFACE MODULE A or B which is provided. Jack J2 connects to the programmer via the eight-foot jumper cable provided.

### EXTERNAL MONITOR—Test Set Accuracy

The test current values displayed on the TEST CURRENT meter are accurate to within  $\pm$  three percent of the meter reading. These limits are contingent upon a clean sine-wave input voltage to the test set. Wave form distortion can cause additional error.

Should greater accuracy be desired, provision is made for connecting external instruments via the EXTERNAL MONITOR jacks on the front panel.

The EXTERNAL MONITOR jacks may be used to check calibration of the instrument and to measure trip times of less than ten seconds more accurately. See Table 9, Page 20 entitled, "HOW TO USE THE EXTERNAL MONITOR."

---

## How to Remove the Solid-state Programmer for Testing

### MicroVersaTrip® Programmers Cat. No. T4VT

1. Push the "PUSH TO TRIP" button on the front of the circuit breaker.
2. Remove the cover protecting the Micro-VersaTrip® programmer.
3. Carefully remove the two-pin flux shifter trip coil connector.
4. Loosen completely the two captive screws that secure the programmer to the sensor package. The programmer may now be removed.

2. Remove the cover protecting the Micro-VersaTrip® programmer.
3. Depress the locking lever on the side of the programmer plug-in base and remove the programmer.
4. Follow the instructions on the back of the programmer to complete removal.

### MicroVersaTrip® Programmers Used with Type AK/AKR/AKD Circuit Breakers

Simply remove the programmer by gently removing it from its plug-in base. In some breakers, this will require the removal of two mounting screws; in others, it will be necessary to depress the locking lever on the side of the programmer plug-in base.

### MicroVersaTrip® Programmers Cat. No. T9VT

1. Push the "PUSH TO TRIP" button on the front of the circuit breaker.



# How to Remove the Solid-state Programmer for Testing

## MicroVersaTrip® Programmers Used with Small Frame POWER BREAK® Circuit Breakers—Frame Size 2000 Amperes or Less (Programmer Types TP4VT20 and TP9VT20)

### Breaker Without the Electrical Operator Accessory

1. Push the "OFF" button on the front of the circuit breaker.
2. Remove the four top cover screws and remove the cover from the breaker. The programmer is now readily accessible.
3. To remove the programmer, release the cover interlock and remove the programmer from its plug-in base with a gentle rocking motion.

### Breakers with the Electrical Operator Accessory

1. Push the "OFF" Button on the front of the circuit breaker.

2. Remove the four top cover screws and remove the cover from the circuit breaker.

3. To remove the programmer, release the cover interlock and remove the programmer from its plug-in base with a gentle rocking motion.

## MicroVersaTrip® Programmers Used with Large Frame POWER BREAK® Circuit Breakers—Frame Size 3000 Amperes or More. (Programmer Types TP4VT25; TP4VT30; TP9VT25; TP9VT30; TP9VT40)

### With or Without the Electrical Operator Accessory

1. Push "OFF" button.
2. Remove four screws holding the escutcheon cover over the programmer. Remove the escutcheon cover.
3. Remove the four remaining screws and remove the cover from the circuit breaker.
4. To remove the programmer, release the cover interlock and remove the programmer from its plug-in base with a gentle rocking motion.

---

## Connecting the Test Set

### Safety Precautions

**WARNING:** BEFORE CONNECTING THE TEST SET TO THE BREAKER, ENSURE THAT THE CIRCUIT BREAKER IS COMPLETELY DISCONNECTED FROM ITS POWER SOURCE. ON DRAWOUT EQUIPMENT, RACK THE BREAKER TO ITS DISCONNECTED POSITION. VERIFY THAT THE BREAKER IS OFF.

**CAUTION:** NEVER DISENGAGE THE PROGRAMMER ON A BREAKER THAT IS ENERGIZED AND CARRYING LOAD CURRENT. THIS WILL OPEN-CIRCUIT THE CURRENT SENSORS, ALLOWING DANGEROUS AND DAMAGING VOLTAGES TO DEVELOP. SEE FIG. 3.

### Connections

#### "PROGRAMMER ONLY" Test—Mode "1" (See Fig. 4)

1. Remove the programmer from the circuit breaker.
2. Connect the test set to the programmer as follows:
  - a. For the four-function Cat. No. T4VT programmer housed in a plastic shell, plug the programmer directly into the space provided on the front panel of the test set.
  - b. For all other programmers, connect one end of the eight-foot female (sockets) connector cable to the programmer and the other end to connector J2 of the test set.
3. It is not necessary to make any connection to the circuit breaker for "PROGRAMMER ONLY" testing. The Fig. 5 connection must be used if "COMPLETE SYSTEM" tests are to be run.



# Connecting the Test Set

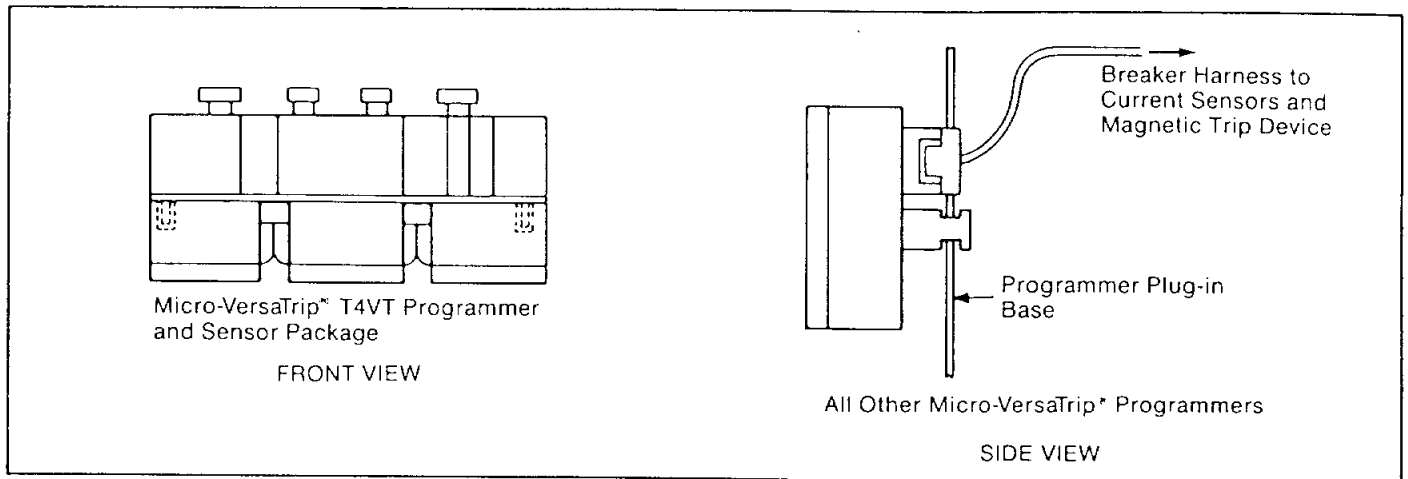

Fig. 3. Normal in-service breaker connection

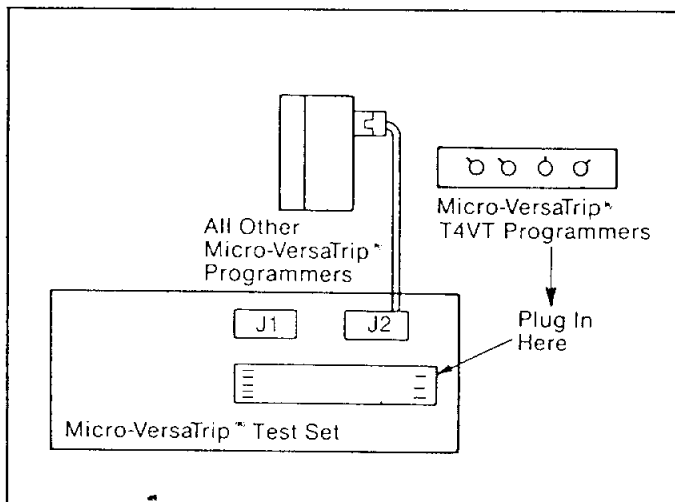

Fig. 4. Connection for "PROGRAMMER ONLY" test

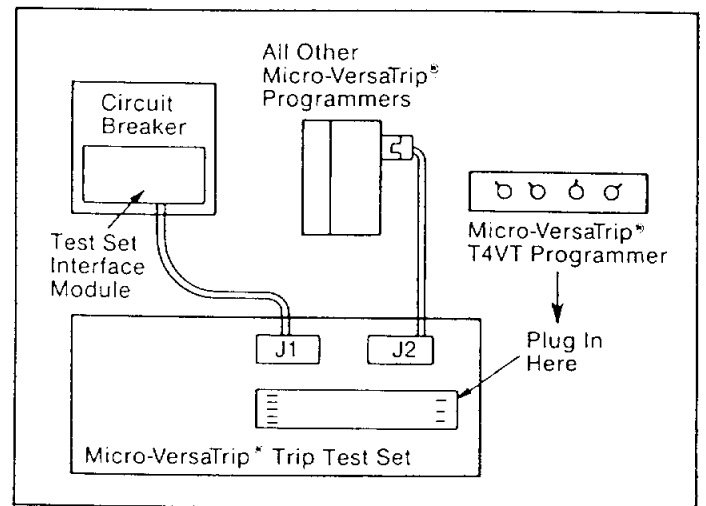

Fig. 5. Connection for "COMPLETE SYSTEM" Test

## "COMPLETE SYSTEM" Test—Mode "2" (See Fig. 5)

1. Connect the test set to the programmer as described in Step 2 of Mode "1" ("PROGRAMMER ONLY" Test) discussed previously.
2. Connect the test set to the circuit breaker as follows:
  - a. For circuit breakers utilizing the four-function Cat. No. T4VT programmer, plug Micro-VersaTrip® TEST SET INTERFACE MODULE B into the sensor package. Make sure to plug the two-pin flux-shifter trip coil connector into the interface module. Tighten the two captive retaining screws and plug the interface module cable connector into test set connector J1.

- b. For all other circuit breakers, plug Micro-VersaTrip® TEST SET INTERFACE MODULE A into the circuit breaker base plate. Connect the cable from the interface module to test set connector J1.

**NOTE:** If the circuit breaker has a cover interlock mechanism such as in Power-Break® circuit breakers, it will be necessary to install the circuit breaker cover to close the breaker. This means that the connector cable from the interface module must be routed through the programmer window in the cover before the cover is applied.



# Preliminary Test Procedure

The following procedure should be followed before starting functional tests.

1. Position the test set controls as follows:
  - a. TRIP BREAKER—PROGRAMMER ONLY Switch: as desired.
  - b. PROGRAMMER TYPE Switch—Position per programmer type (A or B).
  - c. PROGRAMMER CURRENT SETTING—Must match the programmer current setting.
  - d. TEST SELECTOR—Long Time/Short Time.
  - e. TEST CURRENT ADJUST—Completely counter-clockwise.
2. Record the "IN SERVICE" settings of the programmer so that these set points can be restored upon completion of testing. See page 22.
3. Connect the test set power cord to the 105-125-Vac power source.
4. Turn power switch "ON".

## Functional Tests

**NOTE:** In using the test set, it is never necessary to calculate test current values. If the test set and programmer controls are set as described for each of the functional tests on the following pages, the TEST CURRENT value will correspond to programmer face plate values. (e.g. the meter will read 1.50 for a SHORT TIME PICKUP of 1.5C or for an INSTANTANEOUS PICKUP of 1.5X etc.)

### LONG TIME PICKUP Test

#### Purpose

Verify that pickup occurs within tolerance. Each programmer is equipped with a convenient LED LONG TIME PICKUP light permitting a straight forward visual means of determining when the LONG TIME PICKUP point is reached.

#### Test Procedure

- |   |  |
|---|--|
| <ol style="list-style-type: none"> <li>1. Programmer Settings:<br/>LONG TIME PICKUP (if present)—1.1C</li> <li>2. Position Test Set Controls:<br/>PROGRAMMER CURRENT SETTING—Must match the programmer's CURRENT SETTING<br/>TEST SELECTOR—Long Time</li> <li>3. TEST CURRENT—Preset a TEST CURRENT of 0.95</li> <li>4. Push START</li> </ol> | <ol style="list-style-type: none"> <li>5. Slowly increase the TEST CURRENT, carefully observing the LONG TIME PICKUP light on the programmer. The light will indicate when the pickup point is reached.</li> <li>6. Read the TEST CURRENT value at which pickup occurs and compare with the acceptable limits of Table 1 (1.1C setting).</li> <li>7. If the programmer is equipped with an adjustable LONG TIME PICKUP, repeat the above test at 0.8C, 0.9C and 1.0C.</li> </ol> |
|---|--|

**Table 1—Long Time Pickup**

Long Time Pickup Settings	Test Current Limits
0.8C*	0.70–0.91
0.9C*	0.79–1.02
1.0C*	0.87–1.13
1.1C	0.96–1.25

\*These values applicable only to programmers with the adjustable LONG TIME PICKUP option.

**IF TEST RESULTS DO NOT CONFORM, SEE PAGE 21**





# LONG TIME DELAY Test

## Purpose

Verify that the LT characteristic conforms to its upper and lower band limits. It is recommended that measurements be taken at three different values of TEST CURRENT.

### Test Procedure

1. Programmer Settings:  
SHORT TIME PICKUP (if present)—9C.
2. Position Test Set Controls:  
PROGRAMMER CURRENT SETTING—Must match the programmer's CURRENT SETTING.  
TEST SELECTOR—Long Time.  
TEST CURRENT—From Table 2 (using proper Table 2A or 2B), select three test current values. Preset the first value.

**NOTE:** These values must be below the programmer's SHORT TIME PICKUP setting, otherwise, a premature trip signal will be received from that function.

3. Reset timer and push RESET button.
4. Push START. Allow test to run until trip occurs. The trip time should conform to Table 2 limits. For 50-Hz operation, multiply timer readings by 1.2.
5. Repeat the above test at two other TEST CURRENT values.
6. If the programmer is equipped with adjustable LONG TIME DELAY bands, repeat the above test series on the other delay bands (Table 2B).

**Table 2A—T4VT and TP4VT (Four-function) Programmers with Fixed (Non-adjustable) Delay Band**

Test Current	Trip-Time Limits (In Seconds)	
	Min	Max
1.50	209.7	353.7
2.00	117.6	198.2
3.00	51.8	87.3
4.00	29.0	48.8
5.00	18.3	30.8
6.00	12.7	21.4
7.00	9.3	15.7
8.00	7.1	12.0

**Table 2B—Programmers with Adjustable Long Time Delay Bands**

Programmer "Long Time Delay" Setting	Test Current	Trip-Time Limits (In Seconds*)	
		Min	Max
1	1.50	37.3	62.7
	2.00	20.9	35.3
	3.00	9.2	15.6
	4.00	5.1	8.8
	5.00	3.3	5.5
	6.00	2.3	3.9
2	7.00	1.7	2.8
	8.00	1.3	2.2
	1.50	74.9	126.0
	2.00	41.9	70.7
	3.00	18.6	31.2
	4.00	10.4	17.5
3	5.00	6.6	11.1
	6.00	4.6	7.7
	7.00	3.4	5.6
	8.00	2.6	4.3
	1.50	150.4	253.4
	2.00	84.3	141.9
4	3.00	37.2	62.6
	4.00	20.8	35.1
	5.00	13.2	22.2
	6.00	9.1	15.4
	7.00	6.7	11.3
	8.00	5.1	8.7
5	1.50	314.9	530.4
	2.00	176.5	297.2
	3.00	77.7	131.0
	4.00	43.5	73.3
	5.00	27.4	46.2
	6.00	19.1	32.1
6	7.00	14.0	23.6
	8.00	10.7	18.1

\*Reflecting the  $\pm 3\%$  test set accuracy, all test limits are extended beyond the published band limits of the time-current curves. During testing, the test current should be monitored and readjusted if necessary.

IF TEST RESULTS DO NOT CONFORM, SEE PAGE 21



# SHORT TIME DELAY Tests

## Purpose

To test the ST delay functions. There are two possible ST delay tests. Test No. 1, for full-function programmers, checks the three fixed-time delay bands (MIN, INT, MAX). Test No. 2 checks the Short Time I<sup>t</sup> functions when present (standard for four function T4VT and TP4VT programmers; optional for all other programmers). It should be noted that the accuracy of the test sets in SECONDS is  $\pm$  the last digit ( $\pm 0.1$  second). If a more accurate reading is desired, the

EXTERNAL MONITOR jacks may be used to determine the exact programmer trip time. See page 20.

Before beginning this test, it is necessary to determine whether the programmer being tested is equipped with ZONE SELECTIVE INTERLOCKING. This can be determined by noting whether there is a Z suffix in the programmer catalog number. Another method is to connect the programmer to the test set and turn the TEST SELECTOR to the LONG TIME/SHORT TIME—ZONE INTERLOCKED position. If the "ZONE INTERLOCKED" light is lit, the function is present.

---

## Test Procedure

---

### TEST NO. 1—TESTING THE SHORT TIME DELAY—FIXED TIME DELAY BANDS (NOT APPLICABLE TO FOUR-FUNCTION T4VT AND TP4VT PROGRAMMERS).

1. Programmer Settings:
  - CURRENT SETTING—1.0
  - SHORT TIME PICKUP—1.5C
  - SHORT TIME I<sup>t</sup> Switch (if present)—"OUT"
2. Position Test Set Controls:
  - PROGRAMMER CURRENT SETTING—1.0
  - TEST SELECTOR—LONG TIME/SHORT TIME—Standard
3. TEST CURRENT—Preset a value of 3.00
4. Reset timer and push RESET button.
5. Push START—A TRIP light must be obtained. Observe trip time.

**NOTE:** *It is important to observe that the time delay will be dependant on whether or not the programmer being tested is equipped with ZONE SELECTIVE INTERLOCKING. It is, therefore, important to select the proper Table (3A or 3B).*

Test all three delay bands (MIN, INT, MAX). For 50-Hz operation, multiply the timer reading by 1.2.

6. If the programmer is equipped with the ZONE INTERLOCKED Option, continue by testing as follows:
  - a. Position the TEST SELECTOR in the SHORT TIME—ZONE INTERLOCKED position. The test set SHORT TIME—ZONE INTERLOCKED light must come on.
  - b. Repeat Steps 3 through 5.

### TEST NO. 2—TESTING THE SHORT TIME I<sup>t</sup> FUNCTION (IF PRESENT) (STANDARD FOR FOUR-FUNCTION T4VT AND TP4VT PROGRAMMERS).

1. Programmer Settings:
  - CURRENT SETTING—1.0
  - SHORT TIME PICKUP—1.5C
  - SHORT TIME I<sup>t</sup> Switch (if present)—"IN"
2. Position Test Set Controls:
  - Same as Test No. 1
3. TEST CURRENT—Preset one of the TEST CURRENT values shown in Table 3C.
4. Reset the timer and push the RESET button.
5. Push START. Observe trip time.
  - a. Repeat using the other TEST CURRENT values in Table 3C.
6. The following note is applicable only to full-function MicroVersaTrip® programmers.

**NOTE:** *To avoid confusion, the TEST CURRENT is limited to the values in Table 3C. If it is desired to test at higher levels, it should be noted that the I<sup>t</sup> curve is valid only to the point where the I<sup>t</sup> curve intersects the ST fixed delay bands. At this point, the fixed curves take precedence. Note also that if the programmer is a ZONE SELECTIVE INTERLOCK model, the ST delay will always be "MIN" (regardless of the programmer ST delay setting) until a zone interlock signal is received at which time, the delay band becomes the programmer ST delay setting. This will shift the intersect point of the I<sup>t</sup> and fixed delay curves.*



## SHORT TIME DELAY Tests (Cont'd)

### Test No. 1: Short Time Delay—Fixed Delay Bands

**Table 3A—Programmers without ZONE SELECTIVE INTERLOCK Option\***

Test Selector Setting: Short Time Standard		
Delay Band (Seconds)		
Min	Int	Max
0.100 to 0.170	0.220 to 0.300	0.360 to 0.470

\*Use Table 3C for all Four-function T4VT and TP4VT programmers with a Short Time function.

**Table 3B—Programmers Equipped with ZONE SELECTIVE INTERLOCK Option**

Test Selector Setting					
Short Time Standard			Short Time Zone Interlocked		
Delay Band (Seconds)			Delay Band (Seconds)		
Min.	Int.	Max.	Min.	Int.	Max.
0.100 to 0.170	0.100 to 0.170	0.100 to 0.170	0.100 to 0.170	0.220 to 0.300	0.360 to 0.470

### Test No. 2: Short Time Delay— 1<sup>st</sup> Option

**Table 3C—Short Time— 1<sup>st</sup> Option**

Programmer Short Time Pickup Setting	Test Current	Band Limits (Seconds**)
1.5C	2.00	3.39—5.72
	3.00	1.50—2.54
	5.00	0.542—0.917

\*\*Band limits have been expanded slightly to allow for test set accuracy.

IF TEST RESULTS DO NOT CONFORM, SEE PAGE 21



# SHORT TIME PICKUP Test

## Purpose

Verify that pickup occurs within tolerance. This requires two tests at any selected pickup setting:

1. Test for NO PICKUP at the lower tolerance limit.
2. Test for PICKUP at the upper tolerance limit.

## Test Procedure

NO PICKUP	PICKUP
<ol style="list-style-type: none"> <li>1. Programmer settings: LONG TIME DELAY (if present)—4 SHORT TIME DELAY (if present)—Min. SHORT TIME I<sup>2</sup>t (if present)—Out</li> <li>2. Position Test Set Controls: PROGRAMMER CURRENT SETTING—Must match the programmer's CURRENT SETTING. TEST SELECTOR—Short Time</li> <li>3. TEST CURRENT—Preset the lower limit (NO PICKUP) test current from Table 4.</li> <li>4. Reset timer and RESET button.</li> <li>5. Push START. Allow the test to continue for the test duration shown in Table 4, then discontinue by pushing the RESET button. A trip signal must not be obtained during the indicated test duration.</li> </ol>	<ol style="list-style-type: none"> <li>1. Programmer Settings—Same as NO PICKUP.</li> <li>2. Position Test Set Controls—Same as NO PICKUP.</li> <li>3. TEST CURRENT: Preset the upper limit (PICKUP) test current from Table 4.</li> <li>4. Reset timer and RESET button.</li> <li>5. Push START. The trip time must be less than the time shown in Table 4. For 50-Hz operation, multiply timer readings by 1.2.</li> </ol> <p style="text-align: center;"><b>ACTUAL PICKUP VALUE (IF DESIRED)</b></p> <p>Starting at the lower tolerance limit (Table 4), test incremental increases in TEST CURRENT until a trip occurs in less than the time shown in Table 4. Push the PRESET CURRENT button; read the actual pickup value.</p> <p>Because there can be considerable time delay after pickup before the programmer will actually generate a trip signal, a "RUN UP" test is not recommended.</p>

**Table 4—Short Time Pickup**

Programmer ST Pickup Setting	Lower Limit—No Pickup		Upper Limit—Must Pickup	
	Test Current	Test Duration* MUST NOT Trip In LESS Than (Seconds)	Test Current	Criterion* MUST Trip In LESS Than (Seconds)
1.5C	1.31	15	1.70	15
2C	1.75	8	2.27	8
2.5C	2.18	6	2.83	6
3C	2.62	4	3.40	4
4C	3.49	3	4.53	3
5C	4.37	2	5.67	2
7C	6.11	1	7.93	1
9C	7.86	0.6	10.20	0.6

\*The trip-time figures shown do not attempt to define the acceptable short-time delay band, but are merely intended to determine whether the trip signal is coming from the ST or the LT elements.

**IF TEST RESULTS DO NOT CONFORM, SEE PAGE 21**





# INSTANTANEOUS PICKUP Test—Standard

## Purpose

Verify that pickup occurs within tolerance. This requires two tests at any selected pickup setting:

1. Test for NO PICKUP at the lower tolerance limit.
2. Test for PICKUP at the upper tolerance limit.

## Test Procedure

### NO PICKUP

1. Position Test Set Controls:
  - TEST SELECTOR—INSTANTANEOUS, STANDARD COMPONENT TEST SELECTOR—Fully Counter-clockwise.
  - PROGRAMMER TYPE—set on:
    - TYPE A for: T4VT, TP4VT20, TP4VT25, T9VT, TP9VT20, TP9VT25, TAVT20, TVT20
    - TYPE B for: TP4VT30, TP9VT30, TP9VT40, TAVT32, TVT32, TAVT40, TVT40
  - Or determine by running CONVERTER CHECK.
2. TEST CURRENT: Preset the lower limit (NO PICKUP) test current from Table 5A.
3. Reset timer and RESET button.
4. Push START. The unit must not trip.

### PICKUP

1. Position Test Set Controls: Same as NO PICKUP.
2. TEST CURRENT: Preset the upper limit test current from Table 5A.
3. Reset timer and RESET button.
4. Push START. The unit must trip.

### ACTUAL PICKUP VALUE (IF DESIRED)

Starting at the lower tolerance limit (Table 5A) *very slowly* increase the TEST CURRENT until a trip occurs. Push the PRESET CURRENT button and read the actual pickup value.

**Table 5A—Instantaneous Pickup (Standard)**

Programmer Instantaneous Pickup Setting	Test Current	
	Lower Limit (No Pickup)	Upper Limit (Pickup)
1.5X	1.31	1.70
2X	1.75	2.27
2.5X	2.18	2.83
3X	2.62	3.40
4X	3.49	4.53
5X	4.37	5.67
6X	5.24	6.80
7X	6.11	7.93
8X	6.98	9.06
9X	7.86	10.20
10X	8.73	11.33

## Trip Time

To properly test the STANDARD INSTANTANEOUS circuit over its full range of 10X and to keep power dissipation within the programmer at a safe level, a half-sine of current is injected approximately every 200 milliseconds (the actual programmer trip time therefore is less than ½ cycle at the upper test limit of Table 5A). The timer, however, will run continuously during the interval and consequently will indicate a time ranging from practically nothing to 0.3 second (200 msec ± 1 digit of timer).

The test signal used in this test will not initiate a trip signal from the LONG TIME or SHORT-TIME functions.

IF TEST RESULTS DO NOT CONFORM, SEE PAGE 21



# INSTANTANEOUS PICKUP Test—High Level

## Purpose

Verify that pickup occurs within tolerance. This requires two tests at any selected pickup setting:

1. Test for NO PICKUP at the lower tolerance limit.
2. Test for PICKUP at the upper tolerance limit.

## Test Procedure

### NO PICKUP

1. Position Test Set Controls:  
TEST SELECTOR—INSTANTANEOUS, HIGH LEVEL (The HIGH LEVEL light must light if the function is present.)
2. TEST CURRENT: Preset the lower limit. (NO PICKUP) test current from Table 5B.
3. Reset timer and RESET button.
4. Push START. The unit must not trip.
5. Repeat for each of the six positions of the HIGH LEVEL rotary switch.

### PICKUP

1. Position Test Set Controls: Same as NO PICKUP.
2. TEST CURRENT: Preset the upper limit test current from Table 5B.
3. Reset timer and RESET button.
4. Push START. The unit must trip immediately as indicated by little or no discernible timer movement.
5. Repeat for each of the six positions of the HIGH LEVEL rotary switch.

### ACTUAL PICKUP VALUE (IF DESIRED)

Starting at the lower tolerance limit (Table 5B), very slowly increase the TEST CURRENT until a trip occurs. Push the PRESET CURRENT button, read the actual pickup value.

**Table 5B—Instantaneous Pickup—High Level Option**

Programmer High Range Instantaneous Setting	Test Current	
	Lower Limit (No Pickup)	Upper Limit (Pickup)
0.4H	0.330	0.474
0.6H	0.495	0.711
0.8H	0.660	0.948
1.0H	0.825	1.185

IF TEST RESULTS DO NOT CONFORM, SEE PAGE 21



# GROUND FAULT PICKUP Test

## Purpose

Verify that pickup occurs within tolerance. This requires two tests at any selected pickup setting:

1. Test for NO PICKUP at the lower tolerance limit.
2. Test for PICKUP at the upper tolerance limit.

## Test Procedure

### NO PICKUP

1. Position Test Set Controls:  
 TEST SELECTOR—GROUND FAULT  
 PROGRAMMER TYPE—Set on:  
 TYPE A for: T4VT, TP4VT20, TP4VT25, T9VT,  
 TP9VT20, TP9VT25, TAVT20  
 TYPE B for: TP4VT30, TP9VT30, TP9VT40, TAVT32,  
 TAVT40  
 Or determine by running CONVERTER CHECK.
2. TEST CURRENT: Preset the lower limit (NO PICKUP) test current from Table 6.
3. Reset timer and RESET button.
4. Push START. The unit should not trip.  
 Discontinue the test after three seconds by pushing the RESET button.

### PICKUP

1. Position Test Set Controls—Same as NO PICKUP.
2. TEST CURRENT: Preset the upper limit (PICKUP) test current from Table 6.
3. Reset timer and RESET button.
4. Push START. The unit must trip in less than three seconds as indicated by the timer.

### ACTUAL PICKUP VALUE (IF DESIRED)

Starting at the lower tolerance limit (Table 6), test incremental increases in test current until a trip occurs in less than three seconds as indicated by the timer. Push the PRE-SET CURRENT button and read the actual pickup value.

## Table 6—Ground Fault Pickup

Programmer GF Pickup Setting	Test Current	
	Lower Limit (No Pickup)	Upper Limit (Pickup)
0.20X	0.175	0.227
0.22X	0.192	0.249
0.24X	0.210	0.272
0.25X	0.218	0.283
0.26X	0.227	0.295
0.28X	0.244	0.317
0.30X	0.262	0.340
0.34X	0.297	0.385
0.35X	0.306	0.397
0.37X	0.323	0.419
0.40X	0.349	0.453
0.45X	0.393	0.510
0.50X	0.437	0.567
0.60X	0.524	0.680

IF TEST RESULTS DO NOT CONFORM, SEE PAGE 21



# GROUND FAULT DELAY Test

## Purpose

To provide an approximate indication that time delay occurs within the time band selected. Because of the small time magnitudes involved (often tenths of a second), the timer's right digit provides only a rough approximation of the actual trip time. If a more accurate reading is desired, the EXTERNAL MONITOR jacks may be used. See page 20.

## Description

The GROUND FAULT (GF) DELAY curve is a composite curve consisting of an I<sup>2</sup>t portion at the lower current values, followed by fixed (MIN, INT, MAX) time delay bands at higher current levels. Testing is accomplished in two separate tests.

To provide protection against arcing ground faults, the Micro-VersaTrip<sup>®</sup> programmer is equipped with a GF memory. It is important, therefore, in running these delay tests to allow a minimum of five seconds "off time" between each individual energization of the programmer to allow the memory to completely reset; otherwise, the time delay will be low.

Before tests begin, it is necessary to determine whether the programmer under test is equipped with ZONE SELECTIVE INTERLOCKING. This can be determined by noting whether there is a Z suffix in the catalog number on the programmer face plate. Another method is to connect the programmer to the test set and turn the TEST SELECTOR to the GROUND FAULT—ZONE INTERLOCKED position. If the ZONE INTERLOCKED light is lit, the function is present.

## Test Procedure

### TEST NO. 1—I<sup>2</sup>t CURVE

1. Set the programmer GF pickup setting to 0.2X.
2. Position Test Set controls:  
PROGRAMMER TYPE—Set on:  
TYPE A for: T4VT, TP4VT20, TP4VT25, T9VT, TP9VT20, TP9VT25, TAVT20  
TYPE B for: TP4VT30, TP9VT30, TP9VT40, TAVT32, TAVT40  
  
Or determine by running CONVERTER CHECK  
TEST SELECTOR—GROUND FAULT, STANDARD position.
3. TEST CURRENT—Preset one of the test current values shown in Table 7A.
4. Reset timer and push RESET button.
5. Push START—A trip light must be obtained. Observe trip time. For 50-Hz operation, multiply the timer reading by 1.2.
6. Allow five seconds "off-time" for the GF memory to reset.
7. Repeat using the other test current values in Table 7A, allowing five seconds "off-time" between tests.

### TEST NO. 2—FIXED TIME DELAY

1. Set the programmer GF pickup setting to 0.2X.
2. Position Test Set controls—Same as Test No. 1.
3. TEST CURRENT—Preset a reading of 1.000.
4. Reset timer and push RESET button.
5. Push START. A trip light must be obtained. Observe trip time.

**NOTE:** It is important to observe that the time delay will be dependent on whether or not the programmer being tested is equipped with ZONE SELECTIVE INTERLOCKING. Select the proper Table (7B or 7C).

Repeat Steps 4 and 5 for each GF DELAY (MIN, INT, MAX), allowing five seconds "off-time" between tests for the GF memory to reset.

6. If the programmer is equipped with the ZONE SELECTIVE INTERLOCK option, continue by testing as follows:
  - a. Position the TEST SELECTOR in the GF ZONE INTERLOCKED position.
  - b. Repeat Steps 4 and 5 for each GF DELAY (MIN, INT, MAX).





# GROUND FAULT DELAY Tests (Cont'd)

## Test No. 1: Ground Fault Delay—I<sup>2</sup>t Portion of Curve

Table 7A—I<sup>2</sup>t Curve

Programmer Ground Fault Pickup Setting	Test Current	Time Delay Seconds*
0.2X	0.250	0.94—1.70
	0.300	0.67—1.17
	0.400	0.38—0.64

\*Allow at least five seconds between each individual test to allow the programmer GF memory to completely reset, or the time delay will be low.

## Test No. 2: Ground Fault Delay—Fixed Delay Bands

Table 7B—Programmers with ZONE SELECTIVE INTERLOCK Option

Test Selector Setting					
Ground Fault Standard			Ground Fault Zone Interlocked		
Delay Band Seconds*			Delay Band Seconds*		
Min	Int	Max	Min	Int	Max
0.100	0.100	0.100	0.100	0.220	0.360
to	to	to	to	to	to
0.170	0.170	0.170	0.170	0.300	0.470

\*Allow at least five seconds between each individual test to allow the programmer GF memory to completely reset or the time delay will be low.

Table 7C—Programmers without ZONE SELECTIVE INTERLOCK Option

Test Selector Setting: Ground Fault Standard		
Delay Band Seconds*		
Min	Int	Max
0.100	0.220	0.360
to	to	to
0.170	0.300	0.470

\*Allow at least five seconds between each individual test to allow the programmer GF memory to completely reset or the time delay will be low.

**NOTE: For 50-Hz operation, multiply the timer reading by 1.2**

## GROUND FAULT Continuity Test

To test for continuity between the connector and the GROUND FAULT module, check the continuity with an ohmmeter between the points shown in the figure below. There must be continuity between these points. If there is no continuity, do not put the programmer in service.

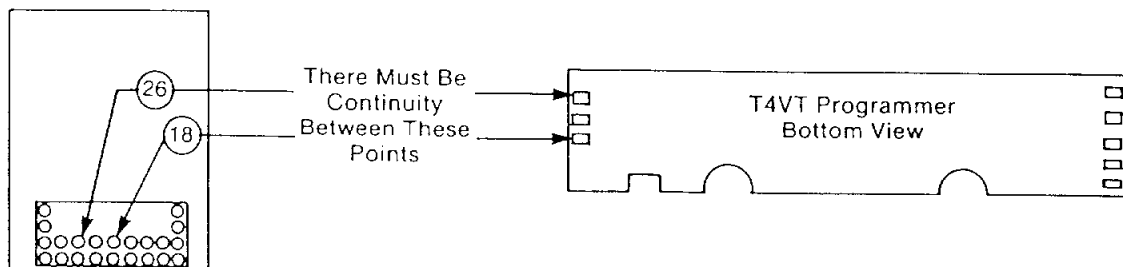

IF TEST RESULTS DO NOT CONFORM, SEE PAGE 21



# CONVERTER CHECK Test

## Purpose

To check the accuracy of the current to voltage converter.

### Test Procedure

- |   |   |
|---|---|
| 1. Position Test Set Controls:<br>TEST SELECTOR—CONVERTER CHECK toggle switch in "SET 15.00" position.<br>EXTERNAL MONITOR Jacks—Make sure nothing is connected across these jacks. | 2. TEST CURRENT:—Adjust for 15.00.<br>3. Flip CONVERTER CHECK toggle switch to the "READ" position and compare the TEST CURRENT reading to the acceptable range shown in Table 8. |
|---|---|

**Table 8**

Programmer Type	Test Current Range
A	4.90—5.10
B	2.45—2.56

IF TEST RESULTS DO NOT CONFORM, SEE PAGE 21



# Component Tests



## ZONE INTERLOCK TRANSMIT Tests

### Purpose

To test ability of the programmer to transmit a ZONE SELECTIVE INTERLOCK command. Two tests are required to test the SHORT TIME and GROUND FAULT INTERLOCK functions. These tests apply only to programmers equipped with the ZONE SELECTIVE INTERLOCK option. This can be determined by noting whether there is a Z suffix in the catalog number on the programmer face plate. Another method is to connect the programmer to the test set and turn the TEST SELECTOR (not the COMPONENT TEST SELECTOR) to the appropriate SHORT TIME or GROUND FAULT ZONE INTERLOCKED position. If the ZONE INTERLOCKED light is lit, the function is present.

### Test No. 1—Short Time Transmit Test

1. Programmer Settings:
  - SHORT TIME I<sup>2</sup>t (if present)—OUT
  - SHORT TIME DELAY—MIN
  - SHORT TIME PICKUP—1.5C
2. Position Test Set Controls:
  - PROGRAMMER CURRENT SETTING—must match the programmer's CURENT SETTING.
  - TEST SELECTOR—Component Tests.
  - COMPONENT TEST SELECTOR—Short Time.
  - TEST CURRENT ADJUST—Zero (fully counter-clockwise).
3. Push the PUSH TO TEST button and hold it depressed. Increase the TEST CURRENT to the point where a trip signal is received (occurs at the SHORT TIME pickup setting). Release the push button.
4. Rotate (increase) the TEST CURRENT ADJUST control one full turn clockwise.
5. Push the PUSH TO TEST button and hold it depressed. The OK light must come on. The TRIP light will also come on.



### Test No. 2—Ground Fault Transmit Test

1. Position Test Set Controls:
  - TEST SELECTOR—Component Tests
  - COMPONENT TEST SELECTOR—Ground Fault.
2. Push the PUSH TO TEST button and hold it depressed. The OK light must come on. The trip light will also come on.

## OPEN DIODE Test



### Purpose

To test the integrity of diodes that make up the input bridge circuitry.

### Procedure

1. Position Test Set Controls:
  - TEST SELECTOR—Component Tests
  - COMPONENT TEST SELECTOR—Open Diodes
  - SEQUENCE Switch—A
2. For T4VT programmers, connect for Mode 2 testing (page 7), or the result will be erroneous.
3. Push the PUSH TO TEST button. The OK light must light. The absence of an OK light is an indication that the diode is open or has an abnormally high series resistance.
4. Repeat for each position of the Sequence Switch. The PUSH TO TEST button *must be released between tests* or an erroneous indication may result.

## SHORTED DIODE Test

### Purpose

To test the integrity of diodes that make up the input bridge circuitry.

1. Position Test Set Controls:
  - TEST SELECTOR—Component Tests
  - COMPONENT TEST SELECTOR—Shorted Diodes
  - SEQUENCE SWITCH—A
2. For T4VT programmers, connect for Mode 2 testing (page 7) or the result will be erroneous.
3. Push the PUSH TO TEST button. The OK light must light. Absence of an OK light is an indication that the diode is shorted or has a high leakage current.
4. Repeat for each position of the Sequence Switch. The PUSH TO TEST button *must be released between tests* or an erroneous indication may result.

## SENSOR CONTINUITY Test

### Purpose

Check continuity of the circuit breaker current sensors.

**NOTE 1.** *The test set does not measure accuracy of the current sensors. This can be established only by testing the complete system, in conjunction with the breaker, using a commercially available high-current/low-voltage ac test set.*

**NOTE 2.** *The test set is not for use in testing the equipment-mounted neutral sensor employed with trip devices equipped with a ground fault trip element for three-phase, four-wire applications. This neutral sensor is excluded from the scope of the circuit breaker/trip device test procedures, and instead should be treated as an integral part of the maintenance and testing activity associated with the switchgear equipment.*



## Procedure

### 1. Position Test Set Controls:

TEST SELECTOR—Components Tests.

COMPONENT TEST SELECTOR—Sensor Continuity

SEQUENCE SWITCH—A

Connect for Mode 2 testing (see Page 7).

2. Ensure all power is removed from the circuit breaker and that the Micro-VersaTrip® Test Set interface module is connected between the circuit breaker and test set.

3. Push the PUSH-TO-TEST button. The OK light must light while the PUSH-TO-TEST button is depressed. Absence of the OK light indicates a high resistance or open circuit in the CT or wiring harness. The PUSH-TO-TEST button must be released between tests.

**Important Note**—There will be no OK light on sequence positions: F, G, H unless the HIGH

LEVEL INSTANTANEOUS function is present (see Page 14).

## Fault Trip Annunciators

As an optional accessory, programmers may be equipped with, pop-out type, fault trip annunciators.

In operation, these annunciators pop out each time their respective trip element delivers a trip signal. If a programmer trips on LT overload, only that indicator is activated. For short circuits, a single indicator serves both the ST and INST elements and is activated by either. The GF indicator responds only to a ground fault trip.

When testing programmers so equipped, the trip annunciators are functioning properly if they are activated each time their respective trip element trips.

### Table 9—How to Use the “External Monitor”

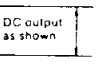
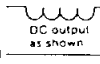
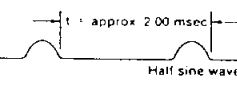
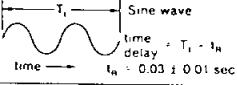
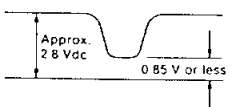
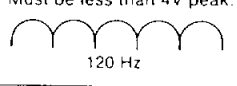
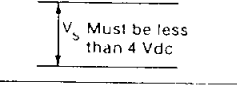
Test Set Settings			Output (±3%) Per Unit (1.00) Test Current	Waveform (For Reference Only)	Comments	
Test Selector	Pro- grammer Current Setting	Pro- grammer Type Switch				
1. LONG TIME/ SHORT TIME Standard and Zone Inter- locked	1.0	—	1.241 Vdc	PRESET CURRENT actuated.   START button activated. (Test Running) 	Note that the values shown in the OUTPUT COLUMN apply only with the PRESET CURRENT control depressed.	
	0.95		1.170 Vdc			Valid only with PRE- SET CUR- RENT button de- pressed.
	0.90		1.100 Vdc			
	0.85		1.029 Vdc			
	0.80		0.958 Vdc			
	0.70		0.817 Vdc			
0.60	0.676 Vdc					
0.50	0.534 Vdc					
2. INSTAN- TANEOUS a. Standard		A B	0.283V PEAK 0.566V PEAK (See Comments)	 t = approx 2.00 msec Half sine wave	Waveform is a half sine with a rep. rate of approximately one pulse every 200 milliseconds. OUTPUT applies with the proper programmer (Type A or B) connected.	
	b. High Level		NO OUTPUT			NO OUTPUT
3. GROUND FAULT		A B	0.200V rms 0.400V rms	 Sine wave time delay = $T_1 - T_2$ $t_n = 0.03 \pm 0.01$ sec	A programmer must be connected to the Test Set to obtain TEST CURRENT. Any Micro-VersaTrip® programmer with the GF function may be used (either Type A or B).	
4. CONVERTER CHECK				DC voltage, DC voltmeter input resistance must be greater than 10 megs.	Output depends on programmer type. For Type A programmers, the output should be approx. 0.500 Vdc; for Type B, 0.250 Vdc at a meter setting of 15.00 (values for reference only). A programmer must be connected to the Test Set.	
5. COMPONENT TESTS a. Short Time Zone Transmit or Ground Fault Zone Transmit				 Approx. 2.8 Vdc 0.85 V or less	Applicable only when the ZONE INTERLOCK function is present in the programmer. The waveform applies during a trip condition.	
	b. Open Diodes			Must be less than 4V peak.  120 Hz	A programmer must be connected. For T4VT programmers, a Mode "2" connection must be made. (See Page 7).	
c. Short Diodes				Indeterminate waveform must be less than 4V peak.	A programmer must be connected, for T4VT programmers, a Mode "2" connection must be made. (See Page 7).	
d. Sensor Continuity				 $V_s$ Must be less than 4 Vdc	DC resistance of current sensor and wiring = $R_s \cdot \frac{909V_s}{14.4-V_s}$ Requires a Mode "2" connection. (See Page 7)	





# If Test Results Do Not Conform



- Carefully review the test instructions to see that the proper procedure is being followed.
- Check all settings on the programmer unit.
- Is the test set TRIP BREAKER—PROGRAMMER ONLY switch in the proper position?
- Is the test set PROGRAMMER TYPE switch in the proper position?
- Does the PROGRAMMER CURRENT SETTING on the test set match the programmer CURRENT SETTING?
- Is the test set TEST SELECTOR in the proper position?
- Are you testing for a function (e.g. Zone Selection Interlocking; High Level Instantaneous option, etc.) that the particular programmer under test does not have?
- Some component tests can only be checked when running the complete system check. See individual test instructions.
- Are all connections engaged (e.g. the two-pin connector at INTERFACE MODULE B and the connectors at J1 and J2)?
- If the timer makes noise but does not operate, push RESET buttons. Manually reset timer.
- When using 50-Hz power, the timer reading must be multiplied by 1.2.
- Two programmers are connected. A four function model is plugged into the Test Set front panel, and a full function model connected to J2. Remove one of them.
- Use the EXTERNAL MONITOR jacks (See Page 20) to check calibration and triptime.
- Are the TEST SELECTOR toggle switch options in the correct position?
- If results do not conform after repeating the test, obtain a replacement programmer. DO NOT REINSTALL A DEFECTIVE PROGRAMMER IN THE CIRCUIT BREAKER!

---

## Completion of Tests



After testing has been completed, the following procedures must be diligently executed preparatory to restoring the circuit breaker to service:

1. Ensure that the breaker is fully disconnected from any power source.
2. Disengage the Test Set connector from the programmer and remove the interface module from the circuit breaker (if used). Reinstall the solid state programmer in the breaker.

**WARNING: FAILURE TO REINSTALL (RECONNECT) THE PROGRAMMER IN THE CIRCUIT BREAKER, VOIDS THE BREAKER'S AUTOMATIC TRIP SYSTEM AND COULD ULTIMATELY RESULT IN LOSS OF LIFE AND/OR SERIOUS PROPERTY DAMAGE.**

3. Reset all trip indicators on the programmer.
4. If the programmer's adjustment knobs were moved to different settings during testing, restore them to their "as received" settings.





# Record of Original "In Service" Programmer Settings

PROGRAMMER CAT. NO. \_\_\_\_\_

CURRENT SETTING \_\_\_\_\_

LONG TIME PICKUP \_\_\_\_\_

LONG TIME DELAY \_\_\_\_\_

SHORT TIME PICKUP \_\_\_\_\_

SHORT TIME DELAY \_\_\_\_\_

SHORT TIME  $I^2t$  \_\_\_\_\_

INSTANTANEOUS PICKUP \_\_\_\_\_

HIGH LEVEL INSTANTANEOUS SETTING \_\_\_\_\_

GROUND FAULT PICKUP \_\_\_\_\_

GROUND FAULT DELAY \_\_\_\_\_

## Notes:



# Schematic Diagram

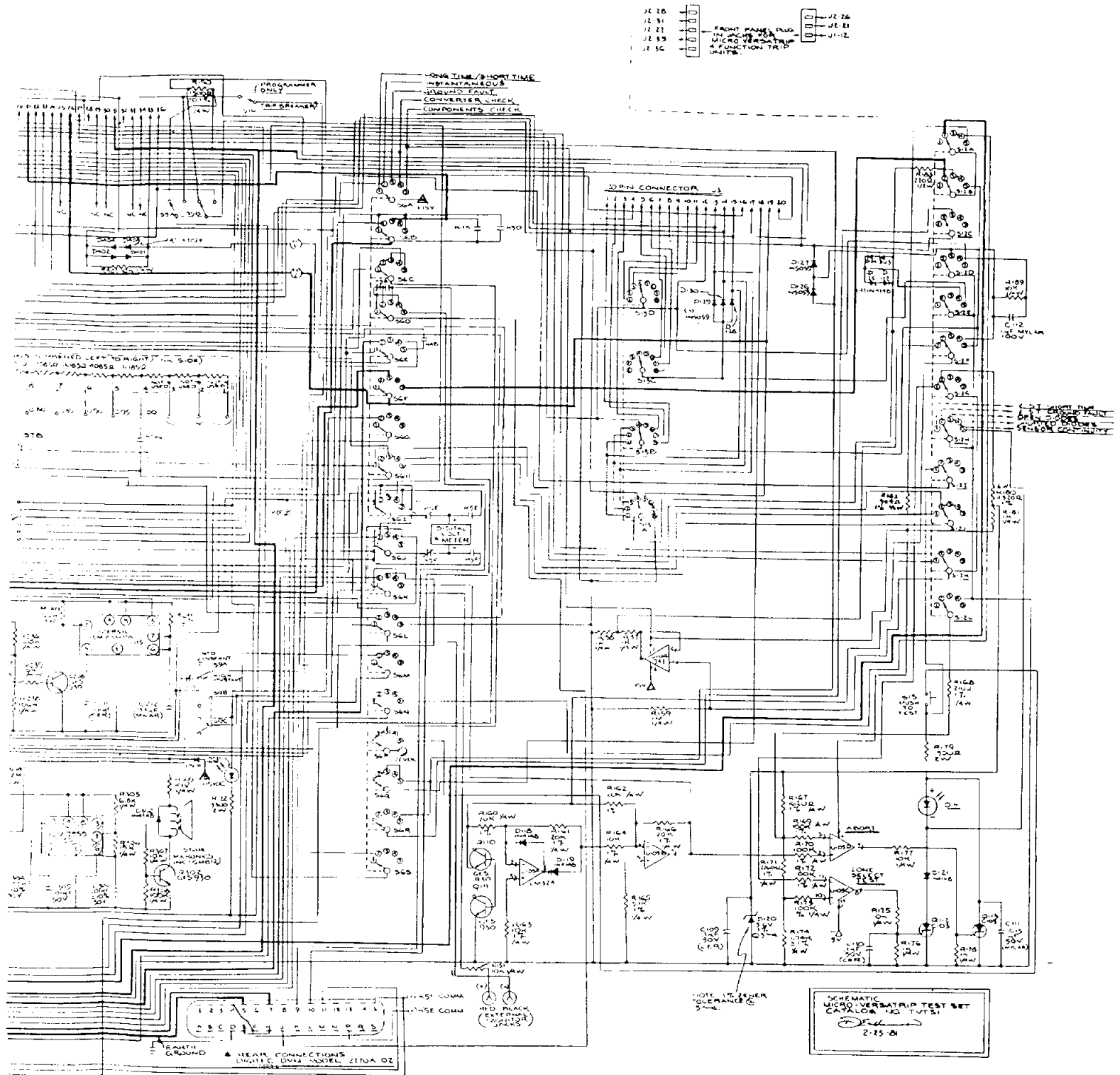
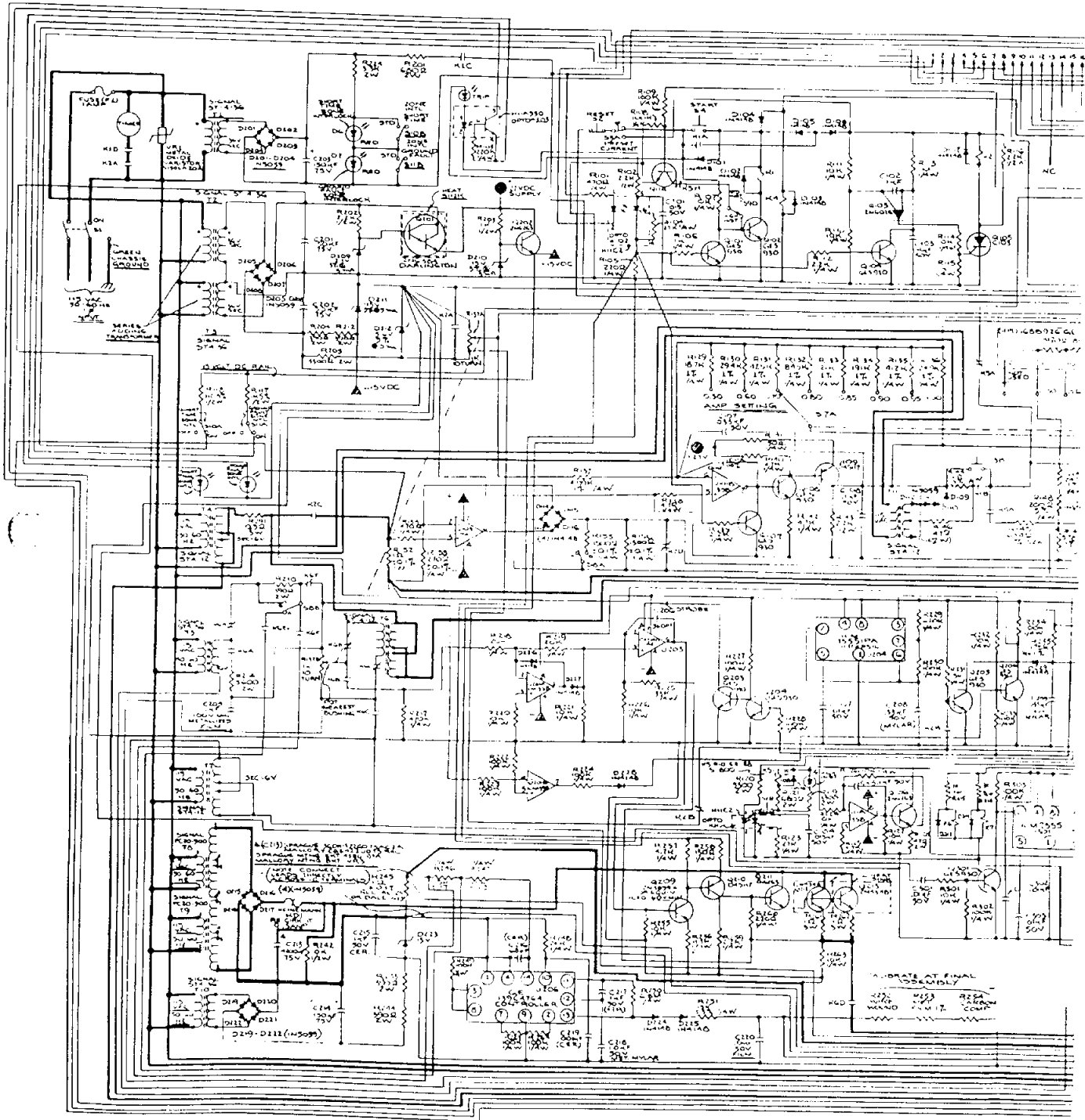

Fig. 6. Schematic diagram









© 1986 GENERAL ELECTRIC COMPANY

*These instructions do not purport to cover all details or variations in equipment nor to provide for every possible contingency to be met in connection with installation operation or maintenance. Should further information be desired or should particular problems arise which are not covered sufficiently for the purchaser's purposes, the matter should be referred to the General Electric Company.*

For further information  
call or write your local  
General Electric  
Sales Office or . . .

General Electric  
Company  
41 Woodford Avenue  
Plainville, CT 06062 U.S.A.

Outside the U.S. write Construction Equipment Export Operation,  
411 Theodore Fremd Ave., Rye, N.Y. 10580 U.S.A.  
GEK-64464B 1186 PSA

**GENERAL**  **ELECTRIC**

