

GEK-90653A

TYS3

**DIRECTIONAL COMPARISON BLOCKING  
PHASE DISTANCE & GROUND DIRECTIONAL  
OVERCURRENT FUNCTIONS**

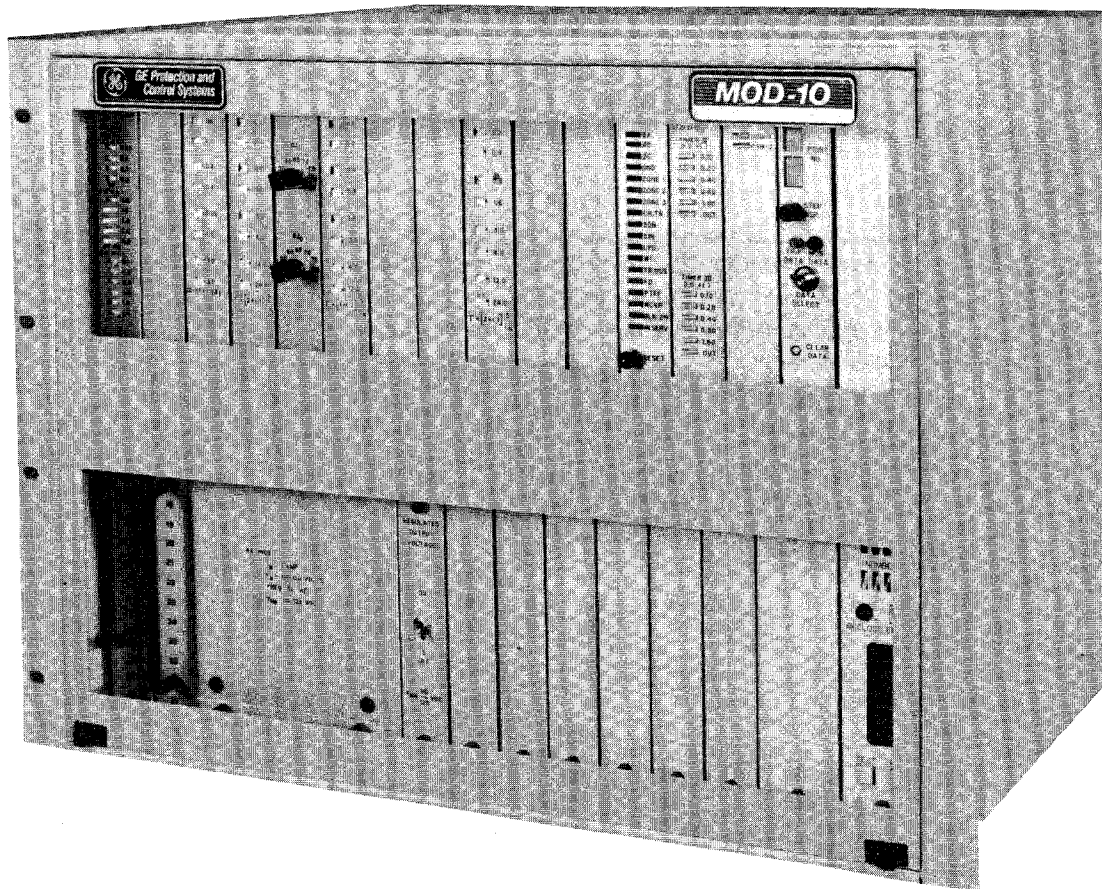

***Meter and Control  
Business Department***

---

General Electric Company  
Protection and Control  
205 Great Valley Parkway  
Malvern, Pennsylvania 19355-0715

*These instructions do not purport to cover all details or variations in equipment nor provide for every possible contingency to be met in connection with installation, operation or maintenance. Should further information be desired or should particular problems arise which are not covered sufficiently for the purchaser's purposes, the matter should be referred to the General Electric Company.*

*To the extent required the products described herein meet applicable ANSI, IEEE and NEMA standards; but no such assurance is given with respect to local codes and ordinances because they vary greatly.*

---

**INTRODUCTION**

**IN**

**SCHEME DESCRIPTION**

**SD**

**CALCULATION OF SETTINGS**

**CS**

**HARDWARE DESCRIPTION**

**HD**

**MODULES**

**MO**

**ACCEPTANCE TESTS**

**AT**

**PERIODIC TESTING**

**PT**

**SERVICING**

**SE**

**SPECIFICATIONS**

**SP**

**CONTINUOUS MONITOR**

**CM**

**SOFTWARE**

**SO**

**RECLOSER**

**RE**

---



Table of Contents

	Page
LIST OF FIGURES .....	7A
LIST OF TABLES .....	9A
INTRODUCTION (GEA11797) .....	IN
<b>SCHEME DESCRIPTION</b> .....	<b>SD-1A</b>
GENERAL .....	SD-1A
OPTIONS .....	SD-2A
APPLICATION .....	SD-2A
LOGIC DESCRIPTION .....	SD-2A
Pilot Tripping .....	SD-2A
Direct Tripping .....	SD-3A
Line Pickup .....	SD-3A
Out-of-Step Blocking .....	SD-4A
Time-Delayed Distance Backup Tripping .....	SD-5A
Potential Transformer Fuse Failure Protection (PTFF) .....	SD-5A
Target Lamps .....	SD-6A
Other Features .....	SD-6A
Outputs .....	SD-6A
<b>CALCULATION OF SETTINGS</b> .....	<b>CS-1A</b>
<b>DISTANCE FUNCTIONS</b> .....	<b>CS-1A</b>
Positive-Sequence Angle of Maximum Reach, $\phi Z1$ .....	CS-1A
MT Reach and Characteristic Shape, M1 Reach, Reach Extension Factor, Timer II and III Settings .....	CS-1A
<b>WORKED EXAMPLE (distance tripping functions)</b> .....	CS-4A
Distance Function Sensitivity .....	CS-5A
<b>REVERSE-REACHING BLOCKING FUNCTIONS, MB</b> .....	<b>CS-5A</b>
MB Reach .....	CS-6A
Zero-Sequence Current Compensation Factor, K .....	CS-6A
Zero-Sequence Angle of Maximum Reach, $\phi Z0$ .....	CS-6A
MB Characteristic Timer Setting .....	CS-6A
Positive-Sequence Voltage Compensation Factor, KV .....	CS-6A
<b>WORKED EXAMPLE (distance blocking functions)</b> .....	CS-6A
<b>OVERCURRENT FUNCTIONS</b> .....	<b>CS-7A</b>
IPT, Pilot Tripping .....	CS-7A
IPB, Pilot Blocking .....	CS-7A
I $\phi\phi$ , MT Overcurrent Supervision .....	CS-8A
IM, Overcurrent Supervision .....	CS-8A
IDT, Direct Trip .....	CS-8A
TOC, Time Overcurrent .....	CS-9A
I1, Line Pickup Supervision .....	CS-9A
<b>WORKED EXAMPLE (overcurrent functions)</b> .....	CS-9A
<b>OUT-OF-STEP-BLOCKING</b> .....	<b>CS-11A</b>
MOB Characteristic Timer Setting .....	CS-11A
Switch OSB-1 Setting .....	CS-11A
Switch OSB-2 Setting .....	CS-11A
<b>WORKED EXAMPLE (out-of-step blocking)</b> .....	CS-11A
LOGIC TIMER SETTINGS .....	CS-11A
CONTACT CONVERTER VOLTAGE .....	CS-12A
<b>SETTINGS LIST</b> .....	<b>CS-12A</b>
SETTINGS LIST A (Blank Form) .....	CS-13A
SETTINGS LIST B (Worked Example) .....	CS-14A

	Page
<b>HARDWARE DESCRIPTION</b> .....	HD-1
<b>CASE ASSEMBLY</b> .....	HD-1
Construction .....	HD-1
Electrical Connections and Internal Wiring .....	HD-1
Identification .....	HD-1
<b>PRINTED- CIRCUIT BOARD MODULES</b> .....	HD-1
Basic Construction .....	HD-1
Identification .....	HD-2
<b>XTM TEST PLUGS</b> .....	HD-2
Description .....	HD-2
Terminal Designation .....	HD-2
XTM Test-Circuit Connections .....	HD-2
Test Plug Insertion .....	HD-2
<b>CARD EXTENDER</b> .....	HD-3
<b>RECEIVING, HANDLING AND STORAGE</b> .....	HD-3
<b>INSTALLATION</b> .....	HD-4
Environment .....	HD-4
Mounting .....	HD-4
External Connections .....	HD-4
External Connections Test .....	HD-4
Surge Ground Connections .....	HD-5
 <b>MODULES</b> .....	 <b>MO-1A</b>
 <b>ACCEPTANCE TESTS</b> .....	 <b>AT-1A</b>
<b>REQUIRED SETTINGS</b> .....	<b>AT-1A</b>
<b>TEST EQUIPMENT</b> .....	<b>AT-1A</b>
<b>EQUIPMENT GROUNDING</b> .....	<b>AT-1A</b>
<b>TEST CONNECTIONS</b> .....	<b>AT-2A</b>
<b>INITIAL RELAY SETTINGS</b> .....	<b>AT-2A</b>
<b>GENERAL INSTRUCTIONS</b> .....	<b>AT-2A</b>
<b>LEVEL-DETECTOR TESTS</b> .....	<b>AT-3A</b>
Fault-Detector Test .....	<b>AT-3A</b>
IM Detector Test .....	<b>AT-4A</b>
IPB Detector Test .....	<b>AT-4A</b>
ITOC Detector Test .....	<b>AT-4A</b>
IDT Detector Test .....	<b>AT-4A</b>
IPT Detector Test .....	<b>AT-4A</b>
I1 Detector Test .....	<b>AT-5A</b>
<b>V1 DETECTOR TEST</b> .....	<b>AT-5A</b>
<b>NEGATIVE-SEQUENCE DIRECTIONAL TESTS</b> .....	<b>AT-5A</b>
NT Test .....	<b>AT-5A</b>
NB Test .....	<b>AT-5A</b>
<b>M1 REACH TESTS</b> .....	<b>AT-5A</b>
<b>MT REACH TESTS</b> .....	<b>AT-5A</b>
<b>SWITCHED-ZONE TESTS</b> .....	<b>AT-6A</b>
<b>MB TESTS</b> .....	<b>AT-6A</b>
<b>MOB TESTS</b> .....	<b>AT-7A</b>
 <b>PERIODIC TESTING</b> .....	 <b>PT-1A</b>
<b>TESTING THE TYS WITH USER SETTINGS</b> .....	<b>PT-1A</b>
<b>TOLERANCE</b> .....	<b>PT-1A</b>

	Page
CURRENT-LEVEL DETECTORS .....	PT-1A
IM .....	PT-1A
IPB .....	PT-1A
ITOC .....	PT-2A
TOC Time Verification .....	PT-2A
IDT .....	PT-2A
IPT .....	PT-3A
I1 .....	PT-3A
FD .....	PT-3A
REACH TESTS .....	PT-3A
M1 .....	PT-3A
MT .....	PT-4A
Switched-Zone Test .....	PT-5A
MB Reach Test .....	PT-5A
MOB Test .....	PT-6A
SERVICING .....	SE-1A
SPARES .....	SE-1A
WITHOUT THE CONTINUOUS MONITOR MODULE .....	SE-1A
WITH THE CONTINUOUS MONITOR MODULE .....	SE-1A
POWER SUPPLY MODULE .....	SE-3A
SPECIFICATIONS .....	SP-1
RATINGS .....	SP-1
BURDENS .....	SP-1
CONTACT DATA .....	SP-2
REACH-SETTING RANGES .....	SP-2
REACH EXTENSION FACTOR .....	SP-2
OVERCURRENT-FUNCTION-SETTING RANGES .....	SP-3
TOC TIME DIAL .....	SP-3
SUPERVISION-FUNCTION-SETTING RANGES .....	SP-3
COMPENSATION-FACTOR-SETTING RANGES .....	SP-3
REPLICA-IMPEDANCE-ANGLE SETTINGS .....	SP-4
ADJUSTABLE LOGIC TIMERS .....	SP-4
ACCURACY .....	SP-4
CURRENT SENSITIVITY .....	SP-4
DIMENSIONS .....	SP-5
WEIGHT .....	SP-5
CONTINUOUS MONITOR MODULE .....	CM-1
BASIC OPERATION .....	CM-1
ADDITIONAL FUNCTION .....	CM-2
ACCESS OF STORED DATA .....	CM-2
Local Access .....	CM-2
Remote Access .....	CM-3
Clearing the Stored Data .....	CM-5
MODES OF OPERATION .....	CM-5
Local-Display Mode .....	CM-5
Serial-Data-Link-Access Mode .....	CM-6
CONTINUOUS MONITOR ADJUSTMENTS .....	CM-6
CONTINUOUS MONITOR SERIAL LINK USE .....	CM-6
CHECKSUM .....	CM-7

	Page
SOFTWARE .....	SO-1
RECLOSER .....	RE-1A
INTRODUCTION .....	RE-1A
DESCRIPTION .....	RE-1A
Basic Operation .....	RE-1A
Additional Features .....	RE-2A
APPLICATION .....	RE-4A
Block Instantaneous Tripping .....	RE-5A
Selective Reclosing .....	RE-5A
Synchronism Check .....	RE-6A
Delayed Reset .....	RE-6A
PAUSE Function - Dual Use .....	RE-7A
OPERATION .....	RE-7A
RLM131 Inputs and Outputs .....	RE-7A
Time Multiplier .....	RE-7A
Printed-Circuit-Board Assembly .....	RE-7A
Settings .....	RE-8A
Programming .....	RE-8A
Read .....	RE-10A
Power Up .....	RE-12A
Ratings .....	RE-13A
TESTING .....	RE-13A
Recloser Self Test .....	RE-13A
Functional Test .....	RE-15A



LIST OF FIGURES

		Page
Frontispiece	TYS Photograph #8043780-1 .....	1A
Figure SD-1	Out-of-Step Blocking Characteristic .....	SD-5A
Figure SD-2	MOD 10™ Mnemonic Legend .....	SD-8A
Figure SD-3	Logic Internal Diagram Legend .....	SD-9-11A
Figure SD-4	Logic Diagram .....	SD-12A
Figure SD-5	Elementary Diagram .....	SD-13A
Figure CS-1	Phase Distance Functions Characteristic Shapes .....	CS-2A
Figure CS-2	Overreaching Function Load Coordination .....	CS-3A
Figure CS-3	Typical Transmission System .....	CS-4A
Figure CS-4	Time Curve Characteristics .....	CS-15A
Figure HD-1	TYS Relaying System, Front View .....	HD-6
Figure HD-2	TYS Relaying System, Rear View .....	HD-6
Figure HD-3	Outline and Mounting Dimensions .....	HD-7
Figure HD-4	XTM Connections for External-Connection Test for KW and KVAR Away from Bus .....	HD8
Figure HD-5	XTM Connections for External-ConnectioTest for KW and KVAR Into Bus .....	HD-9
Figure MO-1	Module Location, Phase Distance and Ground Directional Blocking .....	MO-1A
Figure MO-2	Front Panel & Internal Switches, ABM11(-) Module .....	MO-2A
Figure MO-3	Internal Switches, ADM112 Module .....	MO-2A
Figure MO-4	Front Panel, AFM12(-) & AFM13(-) Modules .....	MO-3A
Figure MO-5	Front Panel, AFM12(-) Module .....	MO-3A
Figure MO-6	Front Panel & Internal Switches and Links, CTM12(-) Module .....	MO-3A
Figure MO-7	Front Panel, ETM115 Module .....	MO-4A
Figure MO-8	Front Panel, ISM11(-) Module .....	MO-4A
Figure MO-9	Front Panel, ULM233 Module .....	MO-4A
Figure MO-10	Front Panel, ULM256 Module .....	MO-4A
Figure MO-11	Front Panel, VMM11(-) Module .....	MO-4A
Figure MO-12	Internal Links, IOM112 Module .....	MO-5A
Figure MO-13	Front Panel & Internal Fuse, PSM21(-) Module .....	MO-5A
Figure MO-14	Front Panel & Internal Switch, ULM222 Module .....	MO-6A
Figure MO-15	Internal Switches, UTM112 Module .....	MO-6A
Figure AT-1	Level-Detector Test Connections .....	AT-8A
Figure AT-2	V1 Test Connections .....	AT-9A
Figure AT-3	Negative-Sequence Directional Test and MB Unit Test Connections .....	AT-10A
Figure AT-4	M1 & MT Reach Test Connections .....	AT-11A
Figure AT-5	Switched-Zone Test Connections .....	AT-12A
Figure AT-6	MOB Test Connections .....	AT-13A
Figure PT-1	Connections for TOC Time Verification Test .....	PT-7A
Figure SE-1	Measuring Functions Block Diagram .....	SE-4-8A
Figure SE-2	Service Logic .....	SE-9A

	Page
Figure CM-1	Simplified Functional Diagram Depicting Continuous Monitor Operation ..... CM-1
Figure CM-2	Continuous Monitor Module Front Panel ..... CM-3
Figure CM-3	Serial Data Link Connection ..... CM-4
Figure CM-4	Continuous Monitor Phone Connection ..... CM-8
Figure CM-5	Connection for Multiple Continuous Monitors ..... CM-8
Figure CM-6	TAM101 ..... CM-9
Figure RE-1	External Connections, TYS/MOD10™ RLM131 Recloser Module .. RE-18A
Figure RE-2	RLM131 Recloser Front Panel and Setting Table ..... RE-19A
Figure RE-3	Use of BI Contact to Block Instantaneous Trip Prior to First Reclosure RE-20A
Figure RE-4	RI (Reclose Initiate) and Delayed Reclose ..... RE-20A
Figure RE-5	Connections for Two Separate Single-Shot Reclosures, Each with a Different Time Delay ..... RE-21A
Figure RE-6	Connections for Synchronism Check Supervision ..... RE-21A
Figure RE-7	Delay Reset for Ground Faults ..... RE-22A
Figure RE-8	Pause Function, Dual Use ..... RE-22A
Figure RE-9	Front Panel and Internal Links, RLM131 Module ..... RE-23A
Figure RE-10	Functional Test Diagram ..... RE-24A

LIST OF TABLES

	Page
CS-I	IDT, Direct Trip, Operate Signal ..... CS-10A
AT-I	Module Settings, Printed-Circuit-Card Switches and Links ..... AT-2A
AT-II	Module Settings, Front-Panel Switches ..... AT-3A
AT-III	Voltage and Phase Angles for M1 Test ..... AT-5A
AT-IV	Voltage and Phase Angles for M1 Test ..... AT-5A
AT-V	Voltage and Phase Angles for MT Test ..... AT-6A
AT-VI	Voltage and Phase Angles for Switched-Zone Test ..... AT-6A
AT-VII	Voltage and Phase Angles for Switched-Zone Test ..... AT-6A
AT-VIII	Voltage and Phase Angles for MB Test ..... AT-6A
AT-IX	Voltage and Phase Angles for MOB Test ..... AT-7A
PT-I	Tolerances at Various Test-Current Levels ..... PT-1A
PT-II	Current and Voltage Phase Angles for M1 Test ..... PT-3A
PT-III	Test Currents for M1 Test ..... PT-4A
PT-IV	Test Currents for MT Test ..... PT-4A
PT-V	Current and Voltage Phase Angles for MB Reach Test ..... PT-5A
SE-I	Test-Socket Pin Assignments ..... SE-2A
SE-II	Continuous Monitor Point Number Assignments ..... SE-2A
SP-I	Reach-Setting Ranges ..... SP-2
SP-II	Reach-Extension Factor ..... SP-2
SP-III	Overcurrent-Function-Setting Ranges ..... SP-3
SP-IV	TOC Time Dial ..... SP-3
SP-V	Supervision-Function-Setting Ranges ..... SP-3
SP-VI	Compensation-Function-Setting Ranges ..... SP-3
SP-VII	Adjustable Logic Timers ..... SP-4
SP-VIII	RM for Various Reach Ranges ..... SP-4
RE-I	Reclosure Time Ranges ..... RE-4A
RE-II	Interrupting Ratings of Auxiliary Relay Contacts ..... RE-13A
RE-III	Relay Settings for Functional Test ..... RE-15A







# MOD-10 / TYS3 MODULAR TRANSMISSION LINE PROTECTION SYSTEM

## The TYS3 MOD-10 System for Three Pole Tripping Applications.

The TYS3 MOD-10 System for three pole tripping applications can be supplied with phase distance and ground distance functions or with phase distance and ground directional overcurrent functions. Schemes are available with either combination of functions for operation in the permissive or hybrid mode with an FSK channel, or, in the blocking mode with an OFF-ON channel.

The phase and ground distance functions are of the variable mho type and use multi-input comparators to provide excellent security and fast operating times. The ground distance functions can be operated as reactance functions if so desired (field selectable).

The directional functions are polarized with negative sequence quantities and are thus immune to the effects of mutual coupling. They control zero sequence overcurrent functions which have positive sequence current restraints to provide excellent coverage for high resistance faults. Instantaneous and time overcurrent functions with optional directional control are also provided for tripping independent of the pilot tripping functions.

The entire system is supervised by a fault detector function which prevents operation unless a system disturbance has occurred.

A Microprocessor Monitoring Interface (MMI) module is available to provide instantaneous notification of abnormal conditions in the TYS, as well as functional response data for each TYS trip operation.

A four shot digital microprocessor based reclosing module is also available as an option.

## DESIGN FEATURES

- Variable mho distance characteristics for accuracy, speed and directional integrity
- Field selectable mho or ohm ground distance characteristics
- Fault detector for supervision of all outputs
- Line pickup circuitry
- Out-of-step blocking
- Potential failure detection
- Optional MMI continuous monitor module
- Optional reclosing module

The Microprocessor Monitoring Interface (MMI) module continuously monitors up to 40 points in the TYS system. The module compares the status of the fault detector with the status of the monitored points to recognize abnormal conditions in the TYS. This information is stored in non-volatile memory until accessed and/or removed by the user. The MMI module is also activated when a trip occurs and stores in a separate area of non-volatile memory all of the monitored internal responses associated with the trip. Trip data for up to five events can be stored. Trip data and monitor data are accessed by pushing a button and viewing an LCD display located on the front panel of the module. Data can also be accessed remotely via an optional RS232 interface available with the MMI.

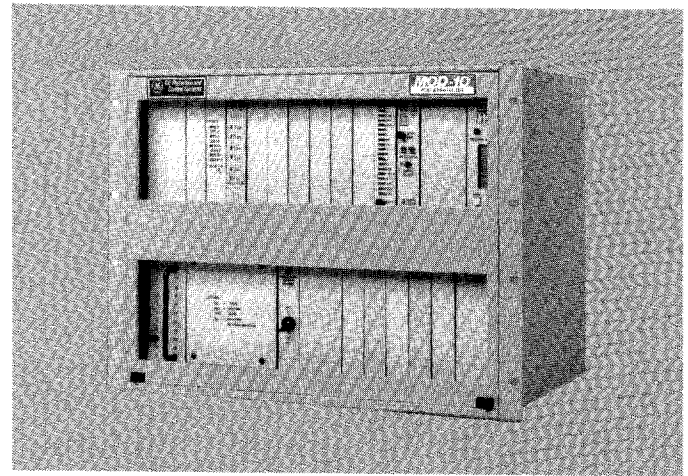

## OPERATING CHARACTERISTICS

### Distance Functions

- Three-phase, phase-to-phase and double-phase-to-ground
  - Variable mho characteristic
- Single-phase-to-ground
  - Reactance or variable mho (field selectable)

### Overcurrent Functions

- Directional
  - Negative sequence polarized
- Overcurrent
  - Zero sequence with positive sequence current restraint

### Operating time typical

- Near end faults — 1/2 cycle\*
  - Remote end faults — 1 cycle\*
- \*add 1/4 cycle for contact tripping

### Application

- Long or short lines
- Two terminal or multi-terminal
- Three-pole tripping
- Any voltage
- Uncompensated lines only (TLS system available for series capacitor compensated lines)

## HARDWARE & PACKAGING

### Draw-out modular construction

- Plug-in modules for test and maintenance
- Standard modular test and connection plugs for current/voltage injection testing

### High-reliability components

- 168 hour burn-in of active semiconductors
- Conservative derating for long life

### Suitable for harsh environment

- Temperature: -20°C to +65°C ambient
- IEEE/ANSI SWC surge tests (C37.90.1)
- GE RFI interference test
- IEC surge withstand test

# MOD-10 TYS3 MODULAR TRANSMISSION LINE PROTECTION SYSTEM

## TECHNICAL DATA

<b>Ratings</b>	
Voltage	• 110/120 vac
Frequency	• 50 or 60 hz
Current	• $I_N = 1$ or 5 amperes
DC control	• 48 vdc (34 to 60 volts)
	• 110/125 vdc (88 to 156 volts)
	• 220/250 vdc (176 to 300 volts)
<b>Maximum permissible currents</b>	
Continuous	• $2 \times I_N$
Three second	• $50 \times I_N$
One second	• $100 \times I_N$
<b>Insulation test voltage</b>	• 2 kv 50/60 hz, one minute
<b>Impulse voltage withstand</b>	• 5 kv peak, 1.2/50 ms, 0.5 joules
<b>Interference test withstand</b>	• 1 Mhz, 2.5 kv peak, decay time of 3 to 6 cycles to 1/2 value
<b>Trip output contacts</b>	• Continuous = 3 amperes, make and carry for trip duty = 30 amperes (per ANSI C37.90)
	• Break 180 VA resistive @ 125/250 vdc
	• Break 60 VA inductive @ 125/250 vdc
<b>Thyristor outputs</b>	• Same as trip contacts except no interrupting rating
<b>Auxiliary contact ratings</b>	• Continuous = 3 amperes, make and carry for 30 seconds = 5 amperes
	• Break 25 watts inductive @ 125/250 vdc, maximum 250 v or 0.5 amperes
<b>Ambient Temperature range</b>	• Storage, -30°C to +75°C
	• Operation, -20°C to +65°C
<b>Humidity</b>	• 95% without condensing
<b>Weight</b>	• 45 pounds (20 kilograms)
<b>Dimensions</b>	
Height	• 14 inches (356 millimeters)
	8 rack units
Width	• 19.1 inches (484 millimeters)
	standard 19 inch rack
Depth	• 16 inches (406 millimeters)
<b>Reach setting ranges</b>	
• Zone 1 functions	
5 to 125 ohms* in .5 ohm steps, or,	} $I_N = 1$ amp
0.5 to 12.5 ohms** in .05 ohm steps	
1 to 25 ohms* in 0.1 ohm steps, or,	} $I_N = 5$ amp
0.1 to 2.5 ohms** in .01 ohm steps	
	* long reach models
	** short reach models
• Zone 2 functions	
10 to 250 ohms in 1.0 ohm steps,	$I_N = 1$ amp
2 to 50 ohms in 0.2 ohm steps,	$I_N = 5$ amps
<b>Overcurrent function setting ranges</b>	
• Pilot tripping function (IPT)	
0.1 to 1 amperes in 0.05 amp steps,	$I_N = 1$ amp
0.5 to 5 amperes in 0.25 amp steps,	$I_N = 5$ amps
• Time overcurrent function (ITOC)	
0.05 to 0.6 amperes in 0.05 amp steps,	$I_N = 1$ amp
0.25 to 3 amperes in 0.25 amp steps,	$I_N = 5$ amps
• Instantaneous overcurrent function (IDT)	
0.4 to 4 amperes in 0.1 amp steps,	$I_N = 1$ amp
2 to 20 amperes in 0.5 amp steps,	$I_N = 5$ amps

## NOMENCLATURE SELECTION GUIDE

### TYS Model Numbers Three-pole Tripping Models

TYS3B * * * * *	
B	8 rack unit case
1	1 ampere rated current
5	5 ampere rated current
5	50 hz rated frequency
6	60 hz rated frequency
B	Blocking with OFF-ON channel
H	Hybrid with FSK channel
P	Permissive with FSK channel
S	Step distance
X	Special customer logic
0	48 vdc
1	110/125 vdc
2	220/250 vdc
1	Single zone scheme (no zone 1)
2	Two zone scheme, long reach*, with zone 1 switching
3	Two zone scheme, short reach**, with zone 1 switching
C	Ground directional overcurrent with pilot, time and instantaneous trip
D	Ground distance functions
E	Ground distance functions plus ground directional overcurrent with pilot, time and instantaneous trip
1	SCR tripping outputs
2	Contact tripping outputs
A	No options
B	Continuous monitor module
C	12 DLA† contact outputs
D	SLR reclosing module
E	Continuous monitor and 12 DLA† outputs
F	Continuous monitor, 12 DLA† outputs, SLR
G	SLR reclosing module and 12 additional DLA points
H	Continuous monitor and SLR reclosing module
X	Special customer options
B	Revision level

\* Zone 1 reach =  $(1 \text{ to } 25) \times 5/I_N$   
 \*\* Zone 1 reach =  $(0.1 \text{ to } 2.5) \times 5/I_N$   
 † In addition to 12 standard DLA outputs

### Sample:

TYS3B56B01E1AB — TYS rated 5 amperes, 60 hz, 48 vdc, suitable for three-pole tripping, blocking scheme logic, with ground distance functions, single zone, with instantaneous and time overcurrent functions, with SCR outputs, no options, revision B.



**GE Protection and Control**

205 Great Valley Parkway  
 Malvern, PA 19355  
 Telephone (215) 251-7000



## SCHEME DESCRIPTION

### GENERAL

The blocking scheme covered by this description and by logic diagram 0179C8200 (see Figure SD-4) uses phase distance function (MT) for the detection of multi-phase faults, and a ground directional overcurrent function (NT and IPT) for the detection of single-line-to-ground (SLG) faults. Modified ground distance functions (MB) and a ground-directional overcurrent function (NB and IPB) are used as the blocking functions.

The following additional functions are also included:

- M1 - Zone 1 phase distance functions (direct trip)
- MOB - Out-of-step blocking function
- IDT - Instantaneous overcurrent direct trip function ( $I_0 - KI_1$ )
- TOC - Time overcurrent direct trip function ( $I_0$ )
- $I\phi\phi$  - MT overcurrent supervision
- IM - Overcurrent supervision ( $I_1 + I_2 + I_0$ )
- $I_1$  - Positive-sequence overcurrent function
- $V_1$  - Positive-sequence under-voltage function
- FD - Fault detector ( $\Delta I_1 + I_2$ )

The phase distance functions are of the variable mho type and use multi-input comparators to provide excellent security and fast operating times. In addition to acting as the overreaching functions, the phase distance functions also control internal-logic timers that can be used to provide time-delayed backup protection.

The directional functions, NT and NB, are polarized with negative-sequence quantities and are thus immune to the effects of zero-sequence mutual coupling. NT and NB control zero-sequence overcurrent functions (with positive-sequence current restraint). These functions provide excellent protection for high-resistance ground faults.

Instantaneous (IDT) and time overcurrent (TOC) functions are used to provide direct tripping independent of the pilot tripping functions. These functions can be directionally controlled at the users' discretion.

The entire system is supervised by a fault detector (FD) function that operates from negative-sequence current ( $I_2$ ) and the change in positive-sequence current  $\Delta I_1$ . The fault detector prevents any trip outputs unless a system disturbance has occurred.

Line-pickup and fuse-failure protection, out-of-step blocking and 12 DLA points are included as standard features in each TYS system.

Tripping outputs can be either SCRs or contacts; refer to the specific model

SD

*These instructions do not purport to cover all details or variations in equipment nor provide for every possible contingency to be met in connection with installation, operation or maintenance. Should further information be desired or should particular problems arise that are not covered sufficiently for the purchaser's purposes, the matter should be referred to the General Electric Company.*

*To the extent required the products described herein meet applicable ANSI, IEEE and NEMA standards; but no such assurance is given with respect to local codes and ordinances because they vary greatly.*

## SCHEME DESCRIPTION

---

number and the Nomenclature Selection Guide in the INTRODUCTION to determine what type of output has been supplied.

### OPTIONS

The following optional functions are available. Further information on these options is provided in this manual. Please use the specific TYS3 model number provided on the equipment and refer to the Nomenclature Selection Guide in the INTRODUCTION section of this book to determine which optional features have been supplied.

\* A microprocessor monitoring module is available to provide information for abnormal conditions in the TYS, as well as to provide trip data for each TYS trip operation. Up to 40 points in the TYS system are continuously monitored by comparing the status of the fault detector with the status of the monitored points to recognize abnormal conditions in the TYS. The module is also activated when a trip occurs, and will store (in a separate area of memory) all of the monitored responses associated with the trip. Trip data will be stored for the last five trip events. Monitor and trip data are stored in non-volatile memory until accessed and/or removed by the user. Trip data and monitor data can be accessed locally via a pushbutton and an LCD display, or remotely via an optional serial data link.

A four-shot SLR microprocessor-based reclosing module is also available. The recloser can be programmed with any or all of the following: one instantaneous reclosure and three time-delayed reclosures.

Twelve additional data-logging (DLA) points are also available, in addition to the twelve that are always provided.

### APPLICATION

The TYS3 system is designed for the following applications:

- Long or short lines
- Multi-terminal lines
- Three-pole tripping
- Any voltage
- Lines without series capacitors

### LOGIC DESCRIPTION

#### Pilot Tripping

For any multi-phase fault on the transmission line, one or more of the MT functions will operate at each terminal of the line and apply one of the inputs to the comparer, AND407. An output from any of the MT functions will also inhibit the blocking functions via OR10 and NOT7, and will stop any carrier that may have been started via OR201, AND209 and OR213. Consequently, carrier will be stopped or will not be started at any terminal of the line, thus there will be no receiver input and no blocking input applied to comparer AND407. Assuming that the out-of-step blocking input (OSB-1) is not applied to the NOT input of AND407, then AND407 will produce an output to initiate tripping following the coordinating time delay set on timer TL1. The coordinating time delay is required to allow a blocking signal to be received from the remote terminal(s) for external faults. It is set equal to the channel time plus signal-propagation time plus a margin of 1 millisecond. Thus, for a 2 millisecond channel and a 186 mile line (1 ms of propagation time), a timer setting of 4 milliseconds would be suitable. Note that tripping is supervised by the fault detector (FD) at AND410, thus confirming that tripping cannot be initiated unless a fault has occurred on the system. The fault detector operates on sequence components and is set very sensitively so that it will

\* Revised since last issue

operate whenever any of the pilot tripping functions operate.

For internal SLG faults, both NT and IPT will operate and apply one of the inputs to the comparer AND407, and will, via OR201, AND209 and OR213, stop any carrier that may have been started. An output from NT will inhibit NB via NOT8, thus preventing NB from starting carrier and from applying a blocking input to AND407. Consequently, AND407 will produce an output and initiate tripping as described above.

The trip output is sealed in via the IM output applied to AND409, thus ensuring that the breaker-failure output (BFI) will be maintained for as long as the fault persists. Note that a carrier-stop output will be maintained for the 50 millisecond dropout time of timer TL1, thus ensuring that the remote terminal(s) of the line will have time to clear in the event that the tripping functions there were slower in operating.

The fault detector input to AND410 (trip output) is sealed in by an output of any of the pilot tripping functions via OR201, OR209, AND207 and OR210. This seal-in is required for three-phase faults wherein the fault detector may only produce a transient output via the  $\Delta I_1$  component of the operating signal used to activate FD.

\* For external faults within reach of any of the pilot tripping functions, one of the MB functions or the NB function will operate to start carrier via OR302 and AND208. A carrier-blocking signal will thus be sent to the terminal(s) where the fault was detected. The receiver output at those terminals will block tripping by removing the upper input from AND407 via CC1 and NOT202. Note that the output of any of the blocking functions is also applied to the lower NOT input of AND407 to block tripping at the terminal near the fault. This NOT input to AND407 forms part of the transient blocking

circuitry that is used to block tripping when clearing external faults or during current reversals that might occur when clearing faults on a parallel line. For example, when an external fault occurs, one of the blocking functions will operate to start carrier and to apply a blocking input to the comparer. The blocking functions have a long dropout time (30 ms) so that carrier will be maintained and tripping will be blocked at the comparer for at least 30 milliseconds following the clearing of the external fault. Thus, if any of the tripping functions were to operate as a result of a current reversal, or a fault-clearing transient, tripping would not be initiated because of the blocking output maintained by the blocking function(s). For internal faults, the tripping functions take priority over the blocking functions and prevent them from operating on the initial occurrence of an internal fault, or cause them to reset if an internal fault were to occur following the occurrence of an external fault. For example, when a fault occurs on the transmission line, at least one of the tripping functions will pick up and cause OR201 and OR10 to produce an output. The output of OR10 causes the output of NOT7 to go to zero, thus removing the upper inputs to AND502 and AND503. The outputs of AND502 and AND503 will be blocked, thus if MB and/or NB are not picked up, they will be prevented from doing so. On the other hand, if MB and/or NB are picked up, they will reset 30 milliseconds later.

### Direct Tripping

Zone 1 phase distance functions (M1) are included in the scheme to provide direct tripping on the occurrence of multi-phase faults. These functions are set to reach not greater than 90% of the positive-sequence impedance of the transmission line.

An instantaneous overcurrent tripping function (IDT) is included in the scheme to provide direct tripping for severe SLG faults. Also included is a time overcurrent tripping function (TOC) that is intended to provide time-delayed backup tripping for SLG faults. Either or both of these functions can be directionally

\* Revised since last issue

## SCHEME DESCRIPTION

---

controlled by the NT function, at the user's discretion.

### Line Pickup

Line pickup circuitry is included to provide tripping in the event that the breaker is closed into a bolted fault, such as might occur if the grounding chains are left on the line following line maintenance. The circuitry consists of the  $I_1$  function, the IM function, the  $V_1$  function, NOT301, TL4, AND302, timer TL7, AND304, timer TL5, AND303 and CC5. It works as follows:

- a. When the line is de-energized, IM and  $V_1$  will drop out, thus indicating that the line is dead. At that time, AND304 will produce an output, which in turn will cause timer TL5 to operate 150 ms later. The output of timer TL5 in turn applies the lower input to AND302 so that if the line is energized and a fault exists,  $I_1$  will pick up and AND302 will produce an output. If contact converter CC5 is energized, AND303 will produce an output at that time to initiate tripping of the breaker. If CC5 is not energized, tripping will occur following the pickup time of timer TL7 (more on TL7 later, in paragraph c).
- b. If the line is energized and no fault exists,  $V_1$  will pick up, and NOT301 will produce an output to energize timer TL4, which will time out 40 milliseconds later to reset timer TL5 via the fast reset input. AND302 will have its lower input removed at that time and the line pickup circuitry is therefore taken out of service.
- c. Timer TL7 is provided for those cases where simultaneous high-speed reclosing is employed at both ends of the line, and where the  $I_1$  function must be set to pick up below maximum load current. In those cases, TL7 allows time for the voltage to return to normal and take the line pickup circuitry out of service before it can trip on load flow. If simultaneous high-speed reclosing is

not used, timer TL7 can be permanently bypassed, by applying a continuous input to CC5. Contact converter CC5 can also be energized by a contact from the breaker control switch so that it is only closed when manual closing of the breaker is called for. In this way, high-speed tripping will be obtained if the line is inadvertently energized with the grounding chains left on.

### Out-of-Step Blocking

The out-of-step-blocking (OSB) circuitry consists of the MOB function, AND201, OR506, NOT201, OR203 and timer TL6. Functioning of the OSB circuitry can best be understood by referring to Figure SD-3 and the logic diagram, Figure SD-4. For an out-of-step condition, the impedance locus will first enter the MOB characteristic and then some time later it will enter the M1 and/or MT functions. When MOB picks up during the power swing it will apply the upper input to AND201, whereas the lower input to AND201 will be present from NOT201 because neither M1 nor MT will be picked up yet. AND201 will then produce an output to energize timer TL6. If the impedance stays between the MOB characteristic and the MT and/or M1 characteristics for the pickup time of TL6, it will time out and produce an OSB output. This output will be fed back to the lower input of AND201 via OR203 to seal in the OSB output for as long as MOB is picked up, even though MT and/or M1 will pick up when the impedance enters their characteristic. The OSB output will reset 50 milliseconds (dropout of TL6) after the impedance swing leaves the MOB characteristic. The OSB output is routed to block reclosing via OR407 in the event tripping is permitted by the scheme, or, it is routed to switches:

- a. OSB-1, which when closed will block zone 1, zone 2, zone 3 and channel tripping, but will allow tripping by the direct tripping overcurrent functions, and,

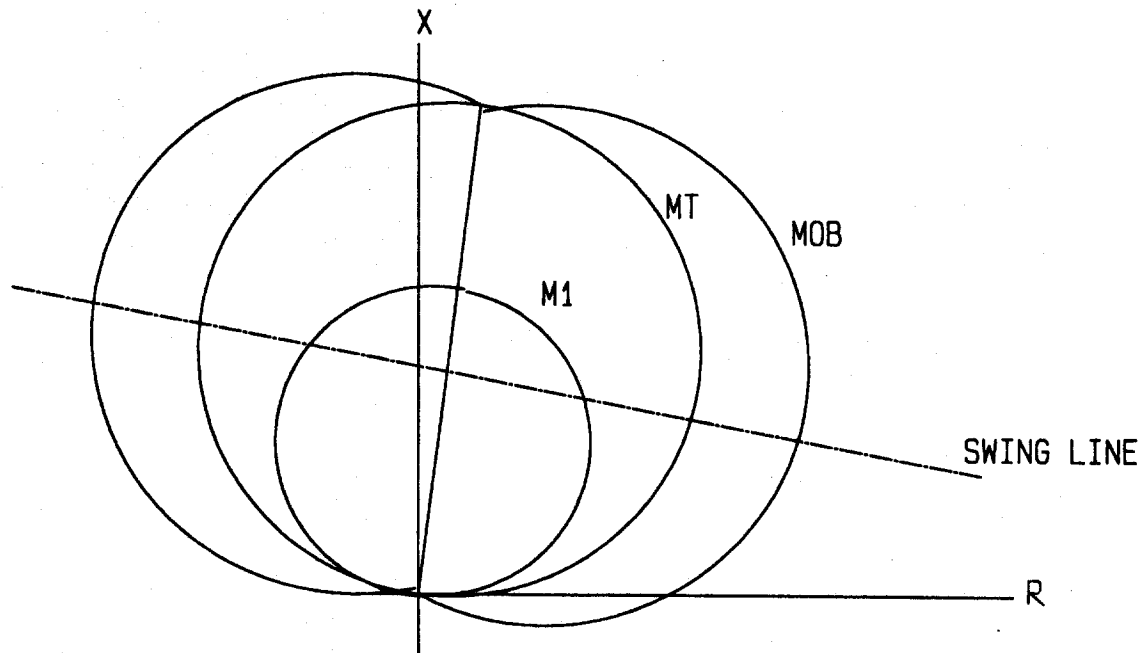

Figure SD-1 (0285A9990-1) Out-of-Step Blocking Characteristic

- b. OSB-2, which when closed will block all tripping by applying the NOT input to AND410.

Timer TL6 has an adaptive pickup characteristic that has an initial pickup setting of 30 milliseconds, but that becomes progressively lower during successive slip cycles. The adaptive pickup is used to provide improved performance during the progressively higher slip frequencies that will typically be encountered if the system is allowed to operate through multiple slip cycles.

#### Time-Delayed Distance Backup Tripping

Timer II and timer III are provided for use with the M1 and MT functions to provide time-delayed backup tripping independent of the pilot channel. Both timers are started when the MT function operates. Each timer has a switch associated with it so that either or both timers may be switched off.

The output of timer II is used to extend the reach of the M1 functions to zone 2 reach when it times out. If at that

time, the fault is within the extended reach of the zone 1 function, tripping will be initiated. In this way, the zone 1 function can be used for dual purposes; i.e., zone 1 tripping directly and zone 2 tripping via the extended reach following the timer II time delay. If zone 1 extended-reach tripping is not required, timer II should be switched off.

The output of timer III will trip directly when it times out. Timer III can be used to provide zone 3 protection by setting the overreaching functions with sufficient reach (if possible), or it can be set to zone 2 time if the extended zone 1 feature is not used and timer II is switched off.

#### Potential Transformer Fuse Failure Protection (PTFF)

The PTFF protection circuitry is made up of AND415, timer TL8, OR411 and AND416. If potential is lost as indicated by an output from the  $V_1$  function, the upper input will be applied to AND415. The lower input will be applied to AND415 if load current is sufficient to operate the IM function, while the middle input to AND415 will depend on whether the fault detector has operated.

If potential is lost due to a blown fuse or fuses, or for other reasons, and there is no fault on the system, the fault detector will not be operated at that time. Thus, AND415 will produce an output that will cause timer TL8 to time out and energize the fuse-failure relay via OR411. The output of OR411 is routed to AND416 to seal in the PTFF output on the output of the V<sub>1</sub> function so that the output will be maintained as long as the potential is below normal. When the potential is returned to normal, V<sub>1</sub> will reset to remove the seal-in and so allow the PTFF output to reset.

If a fault occurs with an attendant drop in potential, the V<sub>1</sub> function will drop out, but the fault detector will also operate; consequently AND415 will be prevented from producing an output. Hence, for fault conditions a fuse-failure output will not be set up.

### Target Lamps

Red LED targets will light and be sealed in whenever a trip occurs. These target lamps can be reset via a pushbutton located on the front of the ULM222 module (see Figure MO-14, in the MODULES section) or via contact converter CC6.

Fault type logic is included in the scheme to provide phase-identified targeting for multi-phase faults via the ØA, ØB and ØC target lamps. For example, only the ØA and ØB LED's on the ULM 222 module will operate for a phase-A-to-phase-B fault, etc.

It is not possible to identify the proper phase for SLG faults because of the lack of ground distance functions; thus only the GND LED will light for SLG faults.

Red LED targets are also included on the ULM222 module for channel trip (CH TR), line pickup trip (LPU), Timer II trip (zone 2) and timer III trip (zone 2/3).

### Other Features

Contact converter CC2 can be used to initiate tripping directly through the TYS relay system.

Contact converter CC3 can be used to block all tripping by the TYS system. When this converter is energized the green LED located on the ULM222 module, Figure MO-14, will not be lit, indicating that the system is out of service.

Contact converter CC6 can be used to reset all of the red LED targets that will be sealed in following any trip operation.

### Outputs

Four "a" contacts or four SCR's are provided for tripping duty. Refer to the specific model number and to the Nomenclature Selection Guide located in the INTRODUCTION of this instruction book to determine which outputs have been supplied.

Two "a" contacts (BFI) are provided for use in the breaker-failure-initiate circuits.

Two "a" contacts are provided for use in the channel carrier start circuits and another two for channel carrier stop circuits.

Two "a" contacts are brought out from the PTFF circuits.

Two "a" contacts (RI) are brought out for use in the reclose-initiate circuits. These contacts will be blocked from operating for the following conditions (NOT input will be applied to AND206):

- a. An output from timer II or timer III; i.e., a time-delayed trip output.
- b. An output from CC2, an external trip input.
- c. An output from the line pickup circuit.

- d. An output from all three MT functions; i.e., a three-phase fault has occurred.
- e. An output from the TOC function, a time-delayed trip output.
- f. An output from the OSB function.

Note that the blocking input to AND206 is sealed in by the trip bus output via OR214 and AND214 so that blocking will be maintained as long as the trip output persists.

The following "a" contacts (identified on logic diagram as DLA1, etc.) are brought out for use with sequence-of-events recorders (SER):

- An output from any MT function (DLA1)
- An output from NT and IPT (DLA2)
- An output from any direct trip function (DLA3)
- An output from CC1 (receiver) (DLA4)
- A trip permission output (DLA5)
- An output from any M1 function (DLA6)
- An output from the line pickup circuit (DLA7)
- An output from any blocking function (DLA8)
- An output from timer III (DLA9)
- An output from AND50 (all three MT's) (DLA10)
- An output from out-of-step blocking (DLA11)
- An output from the fault detector (DLA12)

## MOD 10 MNEMONIC LEGEND

BFI	BREAKER FAILURE INITIATE	NB	NEGATIVE-SEQUENCE BLOCKING DIRECTIONAL FUNCTION
BLK ZN	BLOCKING ZONE	ND	NEGATIVE-SEQUENCE DISTANCE FUNCTION
CC	CONTACT CONVERTER	NDD	PERMISSIVE NEGATIVE-SEQUENCE DISTANCE FUNCTION
CFA	CHANNEL FAILURE ALARM	NT	NEGATIVE-SEQUENCE TRIPPING DIRECTIONAL FUNCTION
CHTR	CHANNEL TRIP	OS	OUT OF STEP
CK, CLK	CLOCK	OSB	OUT OF STEP BLOCKING
CM	CONTINUOUS MONITOR POINT	PD1	POSITIVE-SEQUENCE ZONE 1 DISTANCE FUNCTION
DLA	DATA LOGGING ALARMS	PDB	POSITIVE-SEQUENCE BLOCKING DISTANCE FUNCTION
FD	FAULT DETECTOR	PDT	POSITIVE-SEQUENCE OVERREACHING DISTANCE FUNCTION
FDP	FAULT DETECTOR SUPERVISION	PDX	AUXILLARY ZONE POSITIVE-SEQUENCE DISTANCE FUNCTION
FF	FUSE FAILURE	POSB	POSITIVE-SEQUENCE OUT-OF-STEP BLOCKING FUNCTION
I <sub>00</sub>	PHASE TO PHASE CURRENT (MT OVERCURRENT SUPERVISION)	PTFF	POTENTIAL FUSE FAILURE FUNCTION
I <sub>1</sub>	LINE PICKUP SUPERVISION	RB	RECLOSE BLOCK
I <sub>1S</sub>	POSITIVE-SEQUENCE SUPERVISION	RCVR	CHANNEL RECEIVER
I <sub>1T</sub>	POSITIVE -SEQUENCE TRIPPING SUPERVISION	RI	RECLOSE INITIATE
I <sub>B</sub>	BLOCKING OVERCURRENT SUPERVISION	SUP	SUPERVISION
IDT	DIRECT TRIP OVERCURRENT	TAR	TARGET
IM	OVERCURRENT SUPERVISION	TH	THRESHOLD
IMA	PHASE A SENSITIVE OVERCURRENT FUNCTION	TOC	TIME OVERCURRENT BACKUP
IMB	PHASE B SENSITIVE OVERCURRENT FUNCTION	TP	TEST POINT
IMC	PHASE C SENSITIVE OVERCURRENT FUNCTION	TR BUS	TRIP BUS
I <sub>0</sub>	ZERO-SEQUENCE OVERCURRENT SUPERVISION	TT	TRANSFER TRIP
I <sub>0-KI<sub>1</sub></sub>	ZERO-SEQUENCE OVERCURRENT WITH POS. - SEQUENCE RESTRAINT	V <sub>1</sub>	POSITIVE-SEQUENCE UNDER VOLTAGE FUNCTION
IPB	PILOT BLOCKING	V <sub>A</sub>	PHASE A UNDER VOLTAGE FUNCTION
IPT	PILOT TRIPPING	V <sub>B</sub>	PHASE B UNDER VOLTAGE FUNCTION
IR	RECLOSE INHIBIT	V <sub>C</sub>	PHASE C UNDER VOLTAGE FUNCTION
IT	TRIPPING OVERCURRENT SUPERVISION	V <sub>P</sub>	POLARIZING VOLTAGE
ITOC	TIME OVERCURRENT SUPERVISION	W <sub>I</sub>	WEAK-INFEEED TRIP
LR	LOCKOUT RECLOSE	XMTR	CHANNEL TRANSMITTER
M1	PHASE-PHASE ZONE 1 DISTANCE FUNCTION		
MB	MHO BLOCKING FUNCTION		
MG1	PHASE-GND ZONE 1 DISTANCE FUNCTION		
MOB	MHO OUT OF STEP BLOCK FUNCTION		
MT	PHASE-PHASE OVERREACHING PERMISSIVE TRIP FUNCTION		
MTG	PHASE-GND OVERREACHING PERMISSIVE TRIP FUNCTION		

\* Figure SD-2 (0286A2774 [4]) MOD 10™ Mnemonic Legend

\* Revised since last issue



## LOGIC SYMBOLS

### 3 INPUT AND GATE

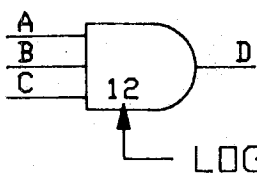

INPUT AT A AND B AND C REQUIRED FOR OUTPUT AT D.

LOGIC DESIGNATION NUMBER

### 2 INPUT AND GATE

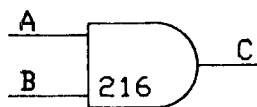

INPUT AT A AND B REQUIRED FOR OUTPUT AT C.

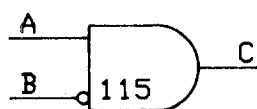

INPUT AT A AND NOT B REQUIRED FOR OUTPUT AT C.

### OR GATE

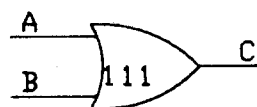

INPUT AT A OR B PRODUCES OUTPUT AT C.

### INVERTER

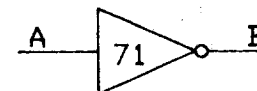

OUTPUT AT B WHEN INPUT NOT PRESENTED AT A.

### NAND GATE

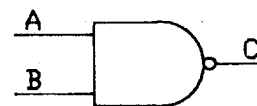

LO INPUT AT A AND B REQUIRED FOR OUTPUT AT C.

### NOR GATE



OUTPUT AT C WHEN NO INPUT IS PRESENT.

## TIMERS

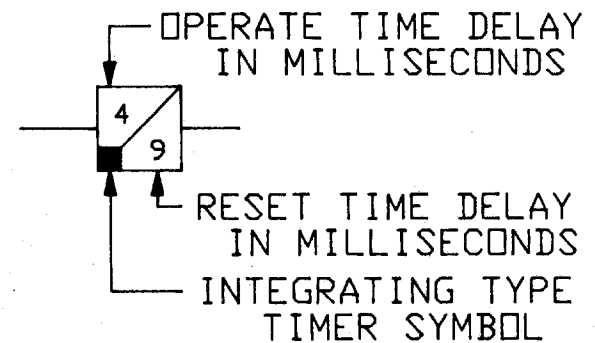
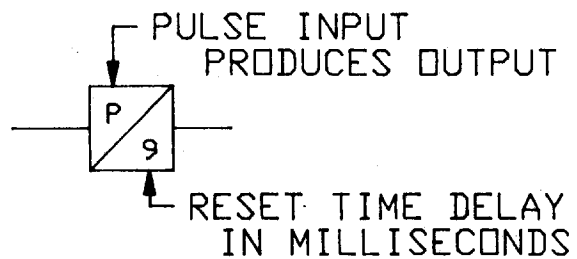
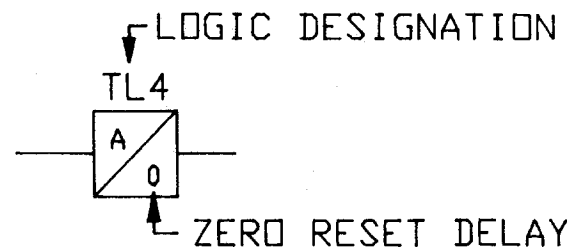

### SUMMING AMP.

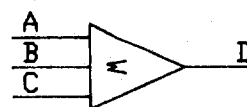

OUTPUT AT D EQUALS THE SUM OF A, B & C INPUTS.

### EXCLUSIVE OR



INPUT AT A OR B REQUIRED FOR OUTPUT AT C. WHEN A AND B ARE EQUAL OUTPUT IS LO.

Figure SD-3 (0286A2775 Sh.1 [3]) Logic and Internal Diagram Legend

# FLIP FLOPS

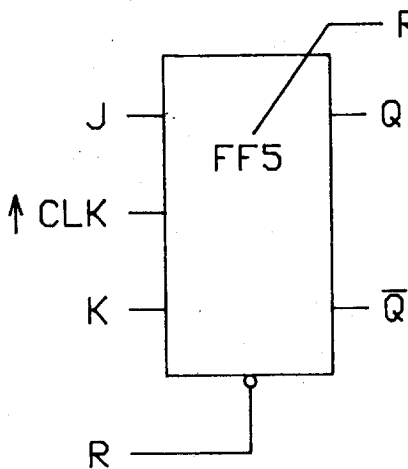

REFERENCE NO.

## JK FLIP FLOP

Q &  $\bar{Q}$  OUTPUTS OCCUR ON POSITIVE EDGE OF CLOCK. R MUST BE LOW FOR OPERATION.

TRUTH TABLE

J	K	Q
L	L	NC
L	H	H
H	L	L
H	H	TOGGLE

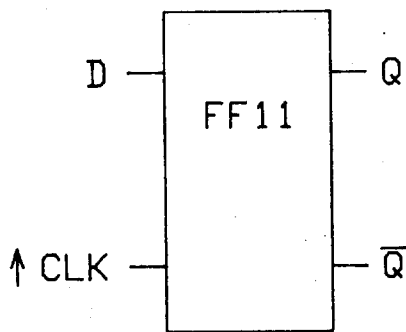

## D FLIP FLOP

Q &  $\bar{Q}$  OUTPUTS OCCUR ON POSITIVE EDGE OF CLOCK.

TRUTH TABLE

D	Q
L	L
H	H

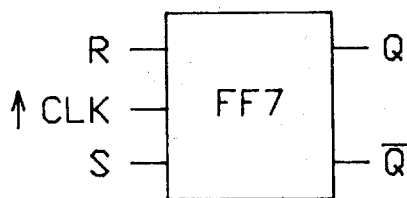

## RS FLIP FLOP

Q &  $\bar{Q}$  OUTPUTS OCCUR ON POSITIVE EDGE OF CLOCK.

TRUTH TABLE

R	S	Q
L	L	NC
H	L	L
L	H	H
H	H	?

NOTE:

H=1 (HIGH INPUT)  
 L=0 (LOW INPUT)  
 NC= NO CHANGE  
 $\bar{Q}$ =INVERSE OF Q

Figure SD-3 (0286A2775 Sh.2 [3]) Logic and Internal Diagram Legend

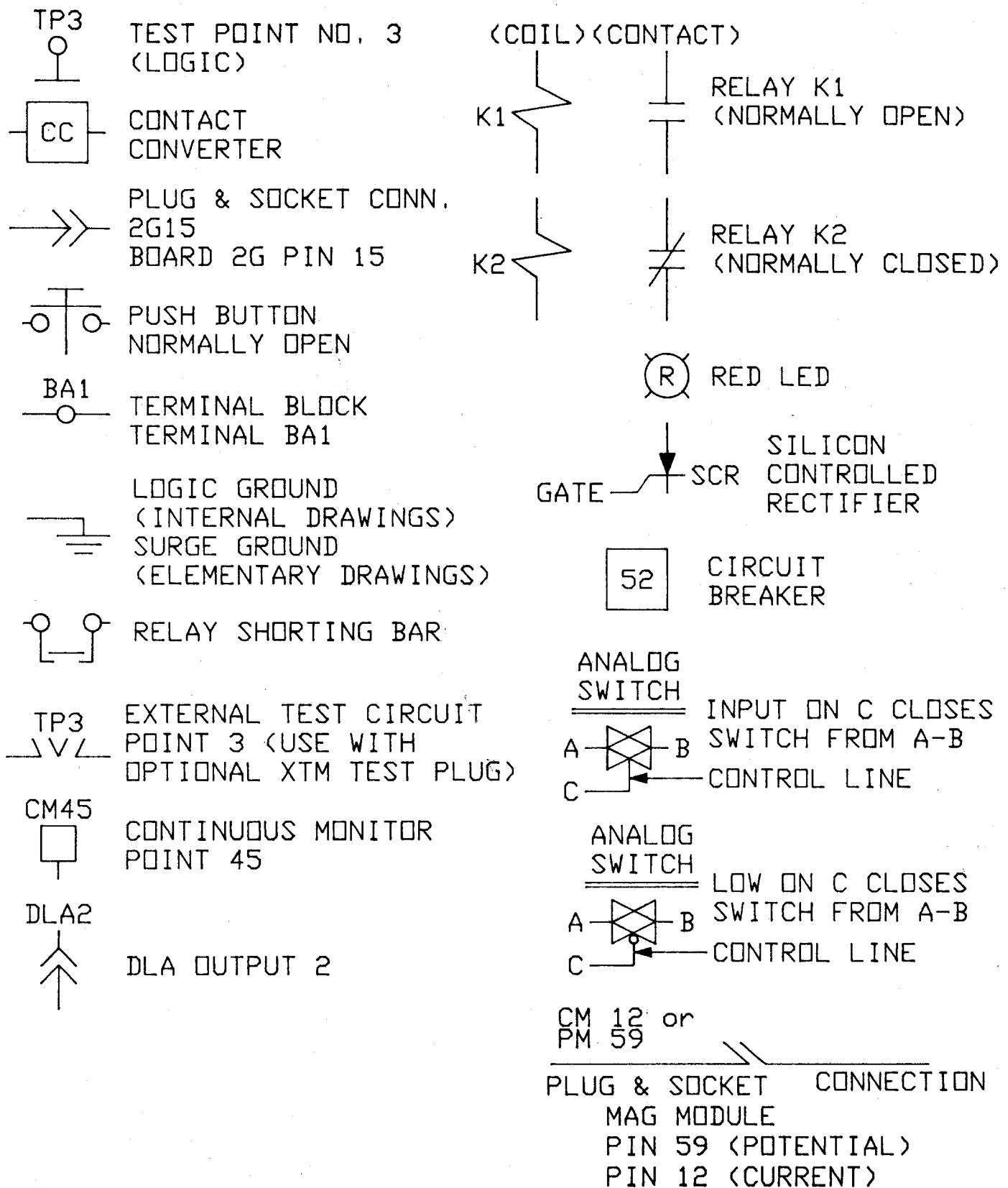
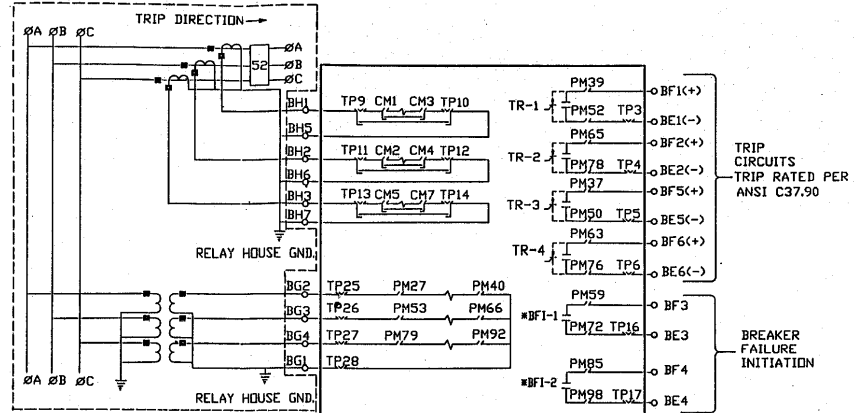
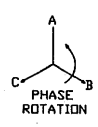
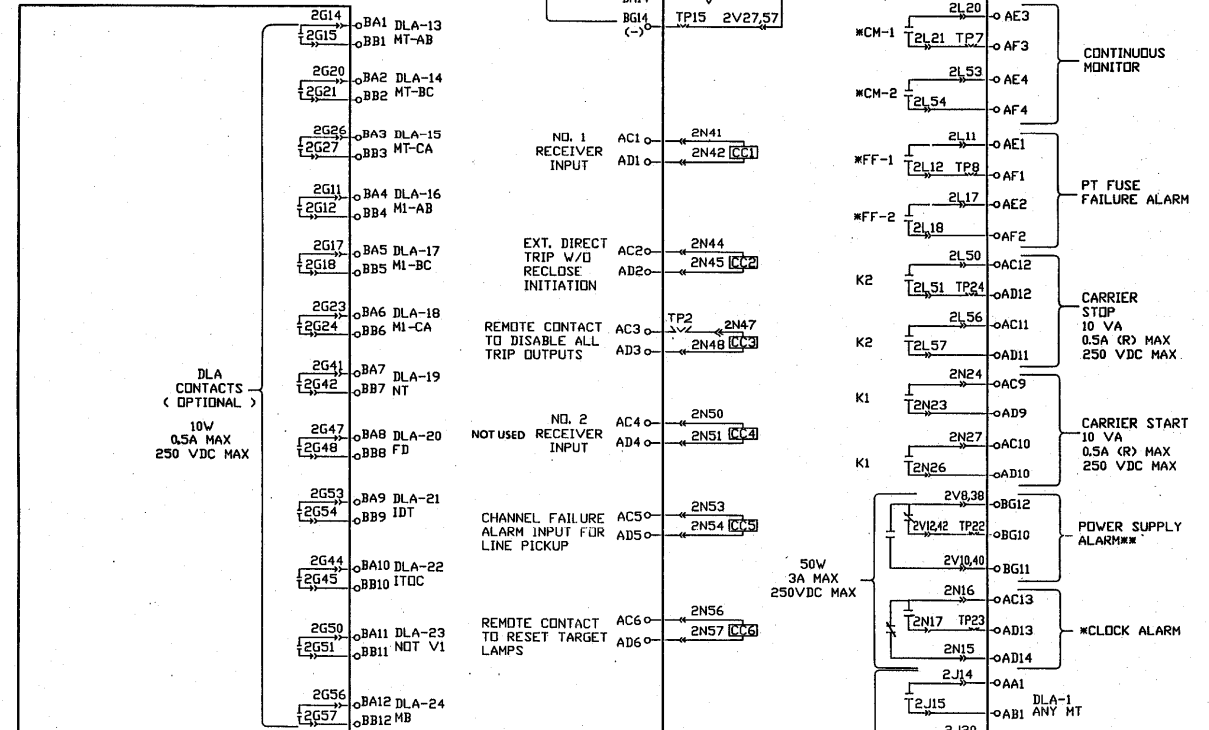

Figure SD-3 (0286A2775 Sh.3 [3]) Logic and Internal Diagram Legend





TYS OPTIONS



OPTIONAL RECLOSER

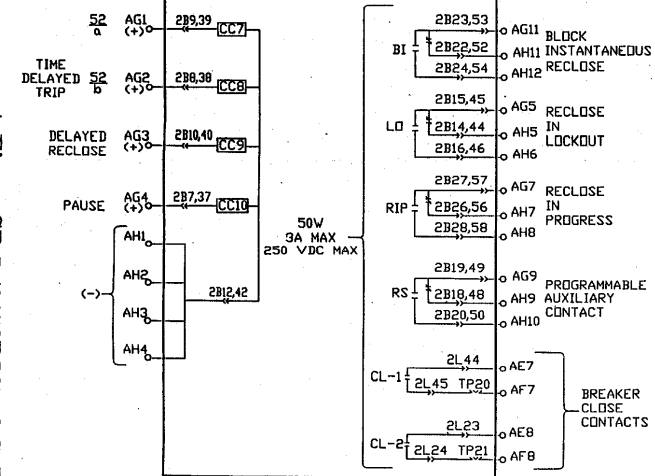

- NOTES:
1. SEE GE DVG 0286A2774 FOR MNEMONIC DEFINITION LEGEND
  2. SEE GE DVG 0286A2775 FOR SYMBOL DEFINITION LEGEND
  3. \* AUXILIARY OUTPUTS 3A, 50W, 250VDC MAX.
  4. \*\* CONTACTS ARE SHOWN DE-ENERGIZED. UNDER NORMAL CONDITIONS CONTACTS ARE ENERGIZED.
  5. --- USER CONNECTION

ADDITIONAL OPTIONS AVAILABLE



\* Revised since last issue

\* Figure SD-5 (0163D7654 [1]) Elementary Diagram

## CALCULATION OF SETTINGS

### DISTANCE FUNCTIONS

Forward Reaching (tripping functions, MT and M1)

The following settings must be made:

- a. Positive-sequence angle of maximum reach ( $50^{\circ}$ - $85^{\circ}$ ,  $5^{\circ}$  step)
- b. Overreaching (MT) reach ( $2$ - $50\Omega$ ,  $0.2\Omega$  step)<sup>†</sup>
- c. Overreaching (MT) characteristic shape ( $90^{\circ}$ ,  $105^{\circ}$ ,  $120^{\circ}$ )
- d. Zone 1 (M1) reach ( $1$ - $25\Omega$ ,  $0.1$  step, or  $0.1$ - $2.5\Omega$ ,  $0.01$  step)<sup>†</sup>
- e. Zone 1 reach extension factor ( $1$ - $10$  x zone 1,  $0.05$  step)
- f. Timer II setting ( $0$ - $3.1$  sec,  $0.1$  sec step)
- g. Timer III setting ( $0$ - $3.1$  sec,  $0.1$  sec step)

<sup>†</sup> Check model number to determine range.

### Positive-Sequence Angle of Maximum Reach, $\theta Z_1$

The positive-sequence angle-of-maximum-reach adjustment is common to all of the distance functions (MT, M1 and MB) and should be set to the angle that is just larger than the angle of the positive-sequence impedance of the transmission line on which the TYS system is applied. Use  $85^{\circ}$  for line angles greater than  $85^{\circ}$ . The setting is made using a switch located on the front panel of the ISM11(-) module, Figure MO-8 in the MODULES section.

### MT Reach and Characteristic Shape, M1 Reach, Reach Extension Factor, Timer II and III Settings

The overreaching functions are always used with the pilot channel to provide high-speed protection for multi-phase faults anywhere on the transmission line. To this purpose, they must be set to

reach beyond the remote terminal of the line. The overreaching functions should never be set less than 125% of the line impedance, but can be set longer than this to provide improved performance or to control timers (II and III) so that time-delayed backup tripping can be provided, independent of the pilot trip.

The first timer (II) can be used to provide zone 2 protection in conjunction with the zone 1 functions by extending their reach to zone 2 when this timer times out.

The second timer (III) works directly with the overreaching functions and can be used to:

- a. initiate zone 3 tripping if the zone 1 functions are used in the extended-reach mode to provide zone 2 backup.
- b. initiate zone 2 tripping if the zone 1 functions are not used in the extended reach mode for 2nd zone backup.

Each timer is set or disabled using switches located on the front panel of the ULM233 module, Figure MO-9 in the MODULES section.

It follows from the above discussion that it is necessary to decide how many zones of backup protection are to be used in a particular application.

If it is acceptable to extend the reach of the 1st zone functions, up to three zones of protection can be provided:

- a. The 1st zone functions would be set to reach no more than 90% of the transmission line impedance. The zone 1 reach setting is made using switches located on the front panel of

## CALCULATION OF SETTINGS

the AFM12(-)/13(-) module, Figure MO-4 in the MODULES section.

- b. The zone 1 reach-extension factor would be set to give the desired 2nd zone reach. For example, a zone 2 reach equal to 125% of the protected line can be obtained with the reach-extension setting set as close as possible to  $125/90$  or 1.39. The reach extension setting is made using switches located on the front panel of the VMM11(-) module, Figure MO-11 in the MODULES section. The zone timer switch (II) would be set to the IN position.
- c. Third (3rd) zone protection would be obtained by setting the overreaching functions (if possible) to reach beyond the remote terminal of any line that emanates from the bus at the remote terminal of the line to be protected. The reach setting is made using switches located on the front panel of the AFM12(-) module, Figure MO-5 in the MODULES section. Zone

timer III would be set to 3rd zone time, and its switch would be set to the IN position. If 3rd zone protection is not required, set the timer III switch to the OUT position and select a reach setting for the overreaching functions that is at least 10% larger than the selected 2nd zone reach.

If it is not acceptable to extend the 1st zone functions in reach, only two zones of protection can be provided:

- a. The 1st zone functions would be set to reach 90% of the transmission line impedance.
- b. The zone timer (II) switch would be set to the OUT position.
- c. The overreaching functions would be set with a suitable 2nd zone reach, keeping in mind the 125% minimum-setting limitation proposed earlier. Set the zone timer switch (III) to the IN position. If zone 2 protection is not

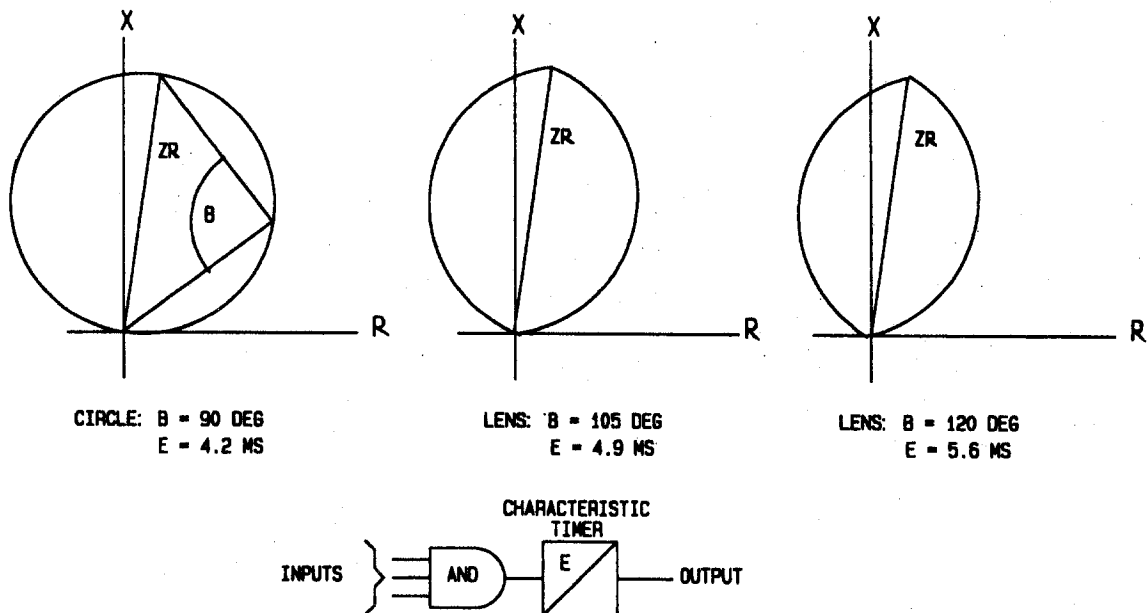
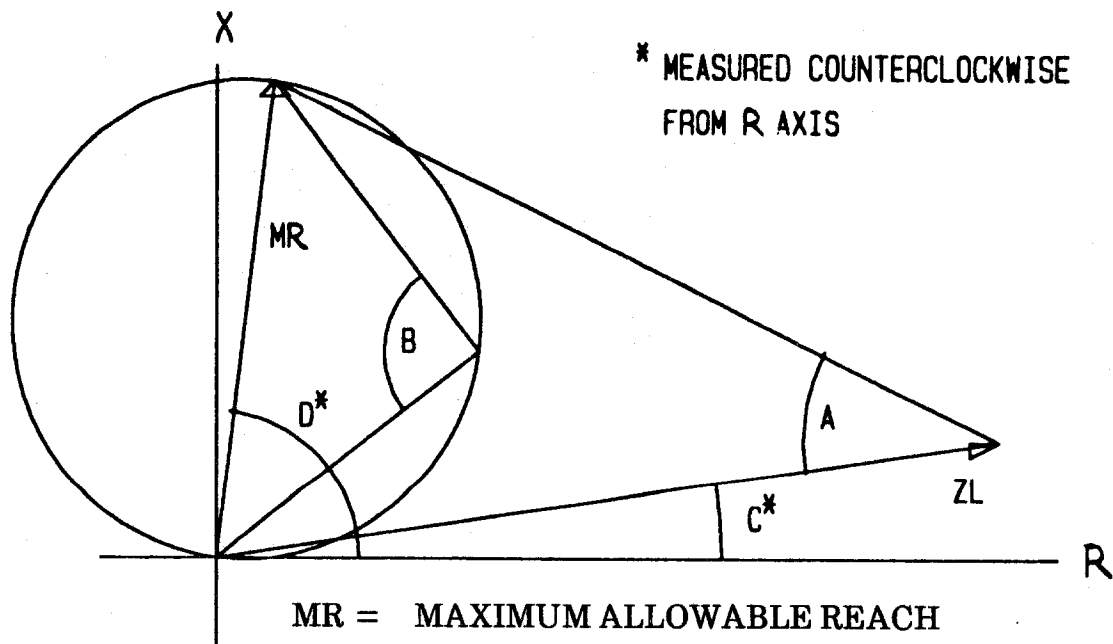

Figure CS-1 (0285A9991-1) Phase Distance Functions Characteristic Shapes



$$MR = \frac{\text{SIN}(A) \times ZL}{\text{SIN}(180 - A - E)} \tag{1}$$

Where:

- |  |  |
|--|--|
| A = 50 for circle (B = 90)                             | C = load impedance angle               |
| A = 65 for lens (B = 105)                              | D = Relay angle of maximum reach;      |
| A = 80 for lens (B = 120)                              | use next higher angle above the        |
| ZL =  Minimum load impedance<br>(maximum load current) | positive-sequence impedance line angle |
|  | E =  D - C                             |

Figure CS-2 (0285A9992-1) Overreaching Function Load Coordination

desired, set the zone timer switch (III) to the OUT position.

After a reach setting has been selected for the overreaching functions, it is desirable to check that the selected reach setting has not exceeded allowable limits. The maximum allowable reach setting that can be made is dependent on the impedance angle of the transmission line, the maximum load flow (minimum load impedance) across the line, and the characteristic shape selected for the distance functions. Three different characteristic shapes can be selected (see Figure CS-1 for details). Larger maximum reaches can be used if the characteristic is made more lenticular, but at a slight increase in operating time because the characteristic timer setting must be increased to obtain the lenticular shape.

To get the best possible operating time, a circular characteristic should be used whenever possible.

The maximum allowable reach setting can be easily calculated if the maximum load flow across the line is known. Please refer to Figure CS-2 for details.

The criterion used for establishing the maximum allowable reach is based on maintaining a 40° angular margin between the angle A and the Characteristic angle B; i.e., B > A by 40°. With this margin maintained, the functions will be secure from operation as a result of load because the blocks created at the input to the characteristic timer (see Figure CS-1) due to load will be approximately 2



# CALCULATION OF SETTINGS

milliseconds less than the timer pickup setting.

Please note that the settings described above are predicated on using the overreaching functions as part of the stepped distance backup protection. If this function is not required as part of the backup, the best possible performance will be obtained from the pilot scheme if the reach of the overreaching functions is set as large as possible, but not larger than the maximum allowable reach described in equation (1) in Figure CS-2.

## WORKED EXAMPLE (distance tripping functions)

As an example of the settings to be made on the distance functions, consider the typical transmission line shown in Figure CS-3 and assume that three zones of protection are to be used in the TYS system located at Station Able. To accomplish this, the 1st zone functions will be increased in reach following zone 2 time to provide zone 2 protection, and, for 3rd zone protection, the overreaching functions will be set, if possible, to reach beyond the remote ends of the lines emanating from Station Baker to Station Charlie and Station Delta.

## Positive-Sequence Angle of Maximum

### Reach, $\phi Z_1$

Set the positive-sequence angle of maximum reach ( $\phi Z_1$ ) to  $85^\circ$ , using the switch located on the front panel of the ISM11(-) module, Figure MO-8.

### M1 Reach

Set the zone 1 functions to reach 90% of the positive-sequence impedance of the transmission line.

$$Z_{R1} = 0.9 \times 10 = 9 \text{ ohms}$$

Set 9 ohms, using the "r" switches located on the front panel of the AFM12(-)/13(-) module, Figure MO-4.

### Second Zone Reach (extension factor), Timer II

Zone 2 protection will be provided by increasing the reach of the zone 1 functions (M1) following a 2nd zone time delay set on timer II. The timer is started by the operation of the MT overreaching functions. Assume that zone 2 reach is to be 125% of the protected line, and that a zone 2 time of 0.2 second is required.

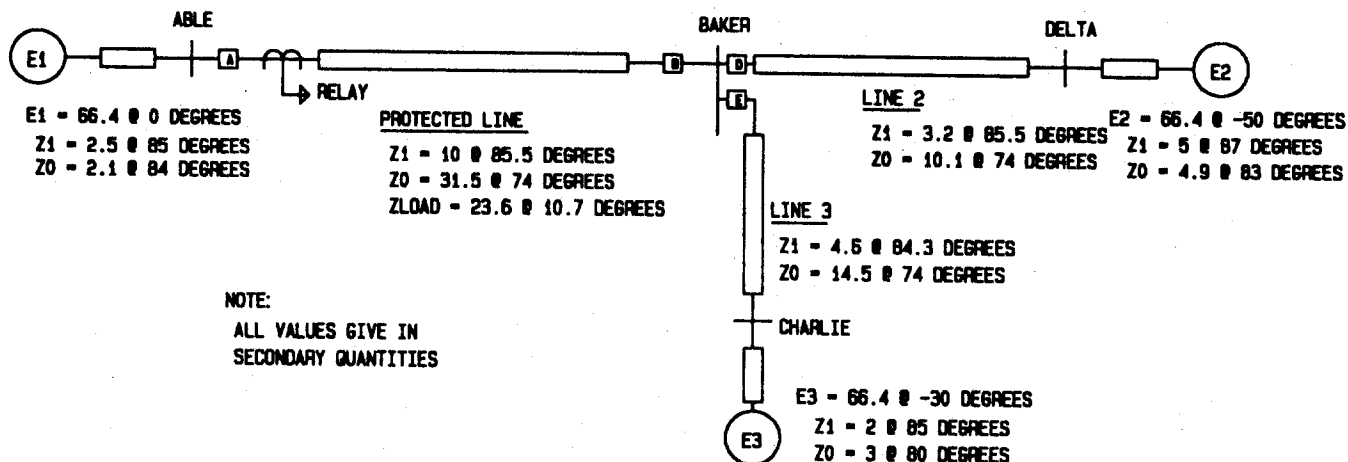

Figure CS-3 (0285A9993) Typical Transmission System

$$Z2 = 1.25 \times 10 = 12.5 \text{ ohms}$$

$$\text{Reach Extension Factor} = \frac{Z2}{Z1} = \frac{12.5}{9}$$

$$= 1.39$$

The nearest available setting for the reach multiplier is 1.40. Set 1.4, using switches located on the front panel of the VMM11(-) module, Figure MO-11.

Set the 0.2-second zone time delay and set the timer switch to the IN position, using the switches marked *TIMER II* and located on the front panel of the ULM233 module, Figure MO-9.

### MT Overreaching Functions (3rd zone)

If the MT overreaching functions are to reach beyond the remote terminals of the lines emanating from Station Baker, the effects of infeed at Station Baker must be taken into account in establishing a reach setting. Fault studies were run with and without load flow for the system shown in Figure CS-3, and it was established that the apparent impedances seen by the relays at Station Able are:

$$Z = 21.6 \text{ ohms, for a three-phase fault at Station Charlie (no load)}$$

$$Z = 19.3 \text{ ohms, for a three-phase fault at Station Delta (no load)}$$

The studies showed that the apparent impedances seen with load flow are less than the values given above.

It is proposed that the MT overreaching functions be set with a reach that is 25% greater than the maximum apparent impedance seen by the functions, and that the zone 3 timer be set to pick up in 0.5 second.

$$ZRT = 1.25 \times 21.6 = 27 \text{ ohms.}$$

It is next necessary to check the maximum allowable reaches that are permitted for the conditions given in Figure CS-3. From equation (1) above and from

the system data given in Figure CS-3, the following maximum reaches can be calculated (use a relay angle of maximum reach of 85°):

$$\begin{aligned} MR &= 21.9 \text{ ohms with } 90^\circ \text{ circle} \\ MR &= 32.8 \text{ ohms with } 105^\circ \text{ lens} \\ MR &= 50 \text{ ohms (maximum available)} \\ &\quad \text{with } 120^\circ \text{ lens} \end{aligned}$$

To obtain the reach of 27 ohms calculated above, the overreaching functions must be set with the 105° lens characteristic. Set 27 ohms, using the "r" switches located on the front panel of the AFM12(-) module, Figure MO-5.

Set the 105° lens characteristic, using the switches located on the board of the UTM112 module, Figure MO-15.

Set the 3rd zone timer to 0.5 second, and set the timer switch to the IN position, using the switches marked *TIMER III* and located on the front panel of the ULM233 module, Figure MO-9.

*Note:* if 3rd zone protection is not required, the overreaching functions can be set with a circular (90°) characteristic, but the reach must be reduced to 21.9 ohms.

### Distance Function Sensitivity

If required, the sensitivity of the distance functions can be found using the calculated settings and the procedures defined in the SPECIFICATIONS section of this instruction book.

### REVERSE-REACHING BLOCKING FUNCTIONS, MB

The following settings must be made:

- MB Reach (2-50Ω, 0.2Ω step)
- Zero-sequence current compensation, K (1-7, 0.1 step)
- Zero-sequence angle of maximum reach,  $\phi Z_0$  (50°-85°, 5° step)
- Characteristic timer setting (80°, 95°, 110°)

CS

- e. Positive-sequence voltage compensation,  $KV_1$  (0-0.3, 0.15 step)

**MB Reach**

The reach of the reverse-reaching blocking functions is dependent on the reach of the overreaching functions at the remote end of the line. The following settings are proposed:

- a. If the MT reach at the remote terminal is less than twice the positive-sequence impedance of the line,

$$MB\ Reach = (MT\ reach) \times 0.85 \quad (2)$$

- b. If the MT reach at the remote terminal is greater than twice the positive-sequence impedance of the line,

$$MB\ Reach = (MT\ reach - Z_{1L}) \times 1.7 \quad (3)$$

Where:  $Z_1$  = positive-sequence impedance of line.

The MB reach is set using the switches located on the front panel of the ABM11(-) module, Figure MO-2.

**Zero-Sequence Current Compensation Factor, K**

The zero-sequence current compensation factor, K, is a function of the positive- and zero-sequence impedances of the transmission line to be protected:

$$K = (Z_0 - Z_1) / Z_1 \quad (4)$$

Where:

$Z_0$  = zero-sequence impedance of line.

$Z_1$  = positive-sequence impedance of line.

The MB zero-sequence current compensation factor is set using the switches located on the board of the ABM11(-) module, Figure MO-2.

**Zero-Sequence Angle of Maximum Reach,  $\phi Z_0$**

The zero-sequence angle of maximum reach should be set to the angle that is just larger than the angle of the zero-sequence impedance of the transmission line on which the TYS system is applied. The zero-sequence angle of reach is set using the switch located on the front panel of the ISM11(-) module, Figure MO-8.

**MB Characteristic Timer Setting**

The characteristic timer settings for the blocking functions should be set  $10^\circ$  less than the characteristic timer setting of the overreaching functions at the remote terminal of the line. The characteristic timer setting is made using the switches located on the board of the UTM112 module, Figure MO-15.

**Positive-Sequence Voltage Compensation Factor, KV**

The positive-sequence voltage compensation factor, KV, should be set to zero (0). The setting is made using the switches located on the board of the ABM11(-) module, Figure MO-2.

*WORKED EXAMPLE (distance blocking functions)*

*The system of Figure CS-3 will be used. The blocking functions at Station Baker will be set to coordinate with the settings selected above for the overreaching functions at Station Able.*

**MB Reach**

\* *The reach of the blocking functions will be established using equation (3) above because the reach of the overreaching functions at Station Able (27 ohms) is greater than twice the positive-sequence impedance of the line:*

$$MB\ Reach = (27 - 10) \times 1.7 = 28.9\ ohms$$

\* Revised since last issue

The nearest available setting is 29 ohms. Set 29 ohms, using the "r" switches located on the front panel of the ABM11(-) module, Figure MO-2.

#### Zero-Sequence Current Compensation Factor, K

The zero-sequence compensation factor is calculated using equation (4) above:

$$K = \frac{(31.5 - 10)}{10} = 2.15$$

The nearest available setting is 2.2. Set 2.2, using the switches located on the board of the ABM11(-) module, Figure MO-2.

#### Zero-Sequence Angle of Maximum Reach, $\phi Z_0$

Set the zero-sequence angle of maximum reach,  $\phi Z_0$ , to 75°, using the switch located on the front panel of the ISM11(-) module, Figure MO-8.

#### MB Characteristic Timer

Set the MB characteristic timers for 95°, using the switches located on the board of the UTM112 module, Figure MO-15.

### OVERCURRENT FUNCTIONS

The following overcurrent functions must be set:

- IPT - Pilot tripping (0.1-1.0 per unit, 0.05 step)
- IPB - Pilot blocking (0.05-0.755 per unit, 0.025 step)
- IØØ - MT overcurrent supervision (0.1-1.0 per unit, 0.1 step)
- IM - Overcurrent supervision (0.05-0.755 per unit, 0.025 step)
- IDT - Direct tripping (0.4-4.0 per unit, 0.1 step)

TOC - Time overcurrent (0.05-0.6 per unit, 0.05 step)  
Time dial (0.5-10, 0.5 step)

I<sub>1</sub> - Line pickup (0.2-3.2 per unit, 0.2 step)

#### IPT, Pilot Tripping

IPT uses zero-sequence current with positive-sequence restraint ( $I_0 - K_T I_1$ ). The setting is made in per-unit current, where rated current,  $I_N$ , (1 or 5 amperes) is used as the base, and it is actually in terms of  $3 \times (I_0 - K_T I_1)$ . Positive-sequence current restraint is used to increase the security of the function by making it less sensitive to steady-state unbalances, error currents, etc. It also reduces the number of external faults that will be detected, thus increasing the overall security of the relaying scheme.

For two-terminal line applications, IPT should be set to its minimum setting of 0.1 per-unit for lines less than 100 miles long and 0.15 per-unit for lines greater than 100 miles long, to compensate for the increased charging current. The setting is made using the switches located on the board of the CTM12(-) module, Figure MO-6.

IPT must be set higher than IPB at the remote terminal to assure coordination. For three-terminal line applications the coordination margins indicated by the suggested IPT and IPB settings given here may, in the worst case, have to be doubled. For two- or three-terminal applications, such as cable circuits, where the zero-sequence charging current is significant, the magnitude of charging current should be calculated to establish an adequate coordination margin.

#### IPB, Pilot Blocking

The IPB function uses zero-sequence current with positive-sequence restraint ( $I_0 - K_B I_1$ ). The setting is made in per-unit current, where rated current,  $I_N$ , (1 or 5 amperes) is used as the base, and is actually in terms of  $3 \times (I_0 - K_B I_1)$ . IPB should be set to its minimum setting of 0.05 per-unit current. The setting is made

using the switches located on the board of the ADM112 module, Figure MO-3.

**IØØ, MT Overcurrent Supervision**

IØØ is not a separate overcurrent function but rather an input to the MT phase distance function comparator; however, it acts just like an overcurrent function to establish trip level supervision of MT. IØØ uses delta current for the operating quantity (i.e., I<sub>A</sub>-I<sub>B</sub> for the ØA-B MT function), but its setting is based on phase current. The setting is made in per-unit current, where rated current, I<sub>N</sub>, (1 or 5 amperes) is used as the base.

IØØ must coordinate with IM at the remote terminal since IM provides overcurrent supervision of the MB blocking functions. For two-terminal applications, IØØ should be set for its minimum value of 0.1 per-unit current. For three-terminal applications, the coordination margin should be doubled by increasing the IØØ setting to 0.2. Both of these recommended settings are based on the IM setting suggested below. The setting is made using the switches located on the front panel of the ETM115 module, Figure MO-7.

**IM, Overcurrent Supervision**

The IM function uses positive-, negative- and zero-sequence currents for the operating quantity. It is used for numerous purposes, including supervision of the MB blocking functions. The setting is made in per-unit current, where rated current, I<sub>N</sub>, (1 or 5 amperes) is used as the base.

This function should be set to its minimum setting of 0.05 per-unit current. This setting establishes the MB blocking function current supervision that coordinates with the IØØ settings suggested above. The setting is made using the switches located on the board of the ADM112 module, Figure MO-3.

**IDT, Direct Trip**

The IDT function is used to provide direct tripping for single-line-to-ground (SLG) faults. The setting is made in per-unit current, where rated current, I<sub>N</sub>, (1 or 5 amperes) is used as the base. IDT uses zero-sequence current with positive-sequence current restraint for the operating quantity. Positive-sequence current restraint is used to provide secure operation during steady-state unbalances, error currents, and for external faults. The function can be directionally controlled by the NT function if so desired. In general, directional control should be used when the operating current for a fault behind the function is much greater than the operating current for a fault at the remote terminal of the transmission line. IDT pickup is established by determining the maximum positive value of:

$$\text{Operate Signal} = 3x|I_0| - 0.3x3x|I_1| \quad (5)$$

If IDT is directionally controlled by NT then the operate signal need only be calculated for faults at the remote end of the line. If IDT is not directionally controlled, then it will be necessary to calculate the quantity for faults directly behind the relaying terminal as well as at the remote end of the line. The IDT pickup setting in per unit is then the maximum operate signal plus a margin of 25% of the (3x|I<sub>0</sub>|) used in determining the maximum value of the operate signal, all divided by the rated current, I<sub>N</sub>; i.e.,

$$\text{IDT setting} = \frac{\{3x|I_0| - 0.3x3x|I_1| + 0.25x(3x|I_0|)\}}{I_N} \quad (6)$$

The IDT pickup is set using the switches located on the front panel of the CTM12(-) module, Figure MO-6. Directional control of IDT is implemented via a link located on the board of the CTM12(-) module, Figure MO-6. It is also possible, via the same link, to disable IDT altogether.

## TOC, Time Overcurrent

The TOC function is used to provide time-delayed backup tripping for SLG faults. The TOC function has a very-inverse-time characteristic and uses zero-sequence current as the operating quantity. The setting is made in per-unit current, where rated current,  $I_N$ , (1 or 5 amperes) is used as the base.

$$\text{TOC setting} = 3xI_0/I_N \quad (7)$$

The TOC function can be directionally controlled by the NT function if so desired, Figure MO-6; directional control should be considered if it becomes difficult to coordinate the TOC functions with similar functions in adjacent line sections. The pickup and time-dial setting for the TOC function, Figure CS-4, should be selected to provide coordination with similar functions in adjacent line sections. Both settings are made using the switches located on the front panel of the CTM12(-) module, Figure MO-6.

## $I_1$ , Line Pickup Supervision

The  $I_1$  function operates from positive-sequence current and is provided for use as part of the line pickup scheme (see Logic Description in the SCHEME DESCRIPTION section for details). The setting is made in per-unit current where rated current,  $I_N$ , (1 or 5 amperes) is the base.

$$I_1 \text{ setting} = I_1/I_N \quad (8)$$

$I_1$  should be set no greater than 2/3 of the minimum fault current for an internal three-phase fault at the relay location.

If the minimum fault current is greater than the maximum load current across the line, the  $I_1$  setting can be reduced to provide greater coverage of the line. For this case, a setting of 110% of the maximum load current is proposed. If the  $I_1$  function can be set with a pickup of at least 110% of the maximum load current, contact converter CC5 can be energized continuously to bypass coordinating timer

TL7 (see Logic Description) to obtain faster tripping.

If sequential reclosing is used, or if there is no automatic reclosing, then  $I_1$  can be set below load current, and CC5 can be energized continuously to bypass timer TL7. If high-speed simultaneous reclosing is used and  $I_1$  is set below full-load current, then TL7 should not be continuously bypassed; otherwise tripping might be initiated when picking up the loaded line.

If a power transformer is energized when the line is reclosed, CC5 should not be continuously energized to bypass TL7 if  $I_1$  can pick up on the transformer-inrush current. A conservative approach to determine if  $I_1$  will pick up on the transformer inrush is to calculate the steady-state positive-sequence current for a three-phase through fault just on the other side of the transformer; i.e., at the transformer bushings. If  $I_1$  will pick up for this fault, then TL7 should not be bypassed.

The  $I_1$  function is set using the switches located on the board of the ABM11(-) module, Figure MO-2.

### *WORKED EXAMPLE (overcurrent functions)*

*The system of Figure CS-3 will be used and the overcurrent functions at Station Able will be set.*

#### *IPT, Pilot Tripping*

*Set the IPT function to 0.1 per-unit current, using the switches located on the board of the CTM12(-) module, Figure MO-6 (assume the line length is less than 100 miles).*

#### *IPB, Pilot Blocking*

*Set the IPB function to 0.05 per-unit current, using the switches located on the board of the ADM112 module, Figure MO-3.*

CALCULATION OF SETTINGS

TABLE CS-I

Fault Loc	I <sub>1</sub>	0.3x3xI <sub>1</sub>	I <sub>0</sub>	3xI <sub>0</sub>	Operate Signal 3xI <sub>0</sub> - 0.3x3xI <sub>1</sub>	Load
Able	2.75	2.48	0.52	1.56	-0.92	Y
Baker	2.88	2.59	1.00	3.00	0.41	Y
Able*	2.57	2.31	0.43	1.29	-1.02	Y
Baker*	2.96	2.66	0.92	2.76	0.10	Y
Able**	2.02	1.82	0.42	1.26	-0.56	Y
Baker**	2.12	1.91	1.10	3.30	1.39	Y
Able	1.65	1.49	0.54	1.62	0.13	N
Baker	1.24	1.12	1.06	3.18	2.06	N
Able*	1.25	1.13	0.45	1.35	0.22	N
Baker*	1.30	1.17	1.01	3.03	1.86	N
Able**	1.37	1.23	0.43	1.29	0.06	N
Baker**	1.14	1.03	1.13	3.39	2.36	N

\*Breaker D open      \*\*Breaker E open

I<sub>00</sub>, MT Overcurrent Supervision

Set the I<sub>00</sub> function to 0.1 per-unit current, using the switches located on the front plate of the ETM115 module, Figure MO-7.

IM, Overcurrent Supervision

Set the IM function to 0.05 per-unit current, using the switches located on the board of the ADM112 module, Figure MO-3.

IDT, Direct Trip

The quantities listed in Table CS-I were calculated using the system of Figure CS-3 and for the conditions noted.

From the data, it can be seen that the maximum value of the operate signal is 2.36, and that it is obtained for a fault at Station Baker, with no load flow and with Breaker E open. Knowing this, the pickup setting for IDT can be calculated using equation (6) above.

$$IDT \text{ setting} = \frac{\{3.39 - 1.03 + 0.25 \times 3.39\}}{5} = 0.64 \text{ per unit}$$

Use the next-higher available setting of 0.7 per unit, and make this setting using

the switches located on the front panel of the CTM12(-) module, Figure MO-6.

TOC, Time Overcurrent

It is assumed that TOC will be directionally controlled, and that maximum sensitivity is desired in order to provide protection for high-resistance ground faults; therefore the minimum pickup setting of 0.05 per unit will be used. A time-dial setting of 2.0 will be used. Both of these settings can be made using the switches located on the front panel of the CTM12(-) module, Figure MO-6. Set the directional control to the IN position via the link located on the board of the CTM12(-) module, Figure MO-6.

I<sub>1</sub>, Line Pickup Supervision

From Figure CS-3, the three-phase fault current for a fault just in front of the relay at Station Able is 26.6 amperes, whereas the load current is 2.71 amperes. Assume that more-sensitive protection is required than would be obtained with the proposed setting of 2/3 of the minimum fault current for a fault at the relay. A setting of 110% of the load current of 2.71 amperes will therefore be used.

$$I_1 \text{ setting} = \frac{1.1 \times 2.71}{5}$$

$$= 0.59 \text{ per unit}$$

Use the nearest setting of 0.6 per unit, and make this setting via the switches located on the board of the ABM11(-) module, Figure MO-2.

Further examination of the above calculated data will show that the value of the operate signal for faults at the bus at Station Able is much less than the value obtained for faults at Station Baker; consequently directional control is not required. Set IDT directional control to the OUT position, using the link located on the board of the CTM12(-) module, Figure MO-6.

## OUT-OF-STEP-BLOCKING

The out-of-step-blocking circuitry is described in the overall Logic Description, and the characteristic is illustrated (Figure SD-3), in the SCHEME DESCRIPTION section. The following settings must be made:

- a. MOB characteristic timer setting (32°-124°, 4° step)
- b. Switch OSB-1 setting (IN/OUT)
- c. Switch OSB-2 setting (IN/OUT)

### MOB Characteristic Timer Setting

The MOB characteristic timer setting is dependent on the characteristic timer setting made on the MT functions at the same terminal of the transmission line. Use the following settings:

MT timer setting	MOB timer setting
90 degrees	72 degrees
105 degrees	84 degrees
120 degrees	100 degrees

### Switch OSB-1 Setting

Logic switch OSB-1 can be used to block channel tripping, and to block tripping by the zone 1, zone 2, and zone 3 functions. Line pickup tripping, and

tripping by IDT and ITOC, will be left in service if this switch is set to the IN position. The switch is located on the front panel of the ULM256 module, Figure MO-10.

### Switch OSB-2 Setting

Logic switch OSB-2 can be used to block all tripping when it is set to the IN position. The switch is located on the front of the ULM256 module, Figure MO-10.

*WORKED EXAMPLE (out-of-step blocking)*

### MOB Characteristic Setting

The characteristic timer setting for the MT functions in this example has been determined to be 105°, consequently the MOB characteristic timer should be set to 84°. Make this setting, using the switches located on the board of the UTM112 module, Figure MO-15.

### Switch OSB-1

Assume that all tripping will be blocked during an out-of-step condition; consequently OSB-2 will be set to the IN position. Make this setting, using the switch located on the front panel of the ULM256 module, Figure MO-10. With OSB-2 set to IN, the setting of OSB-1 is inconsequential.

## LOGIC TIMER SETTINGS

Logic timer TL1 is used to provide the coordination delay necessary to allow for a blocking signal to be received from the remote terminal of the transmission line before tripping can be initiated (see Logic Description). The timer has a range of 0-15.75 ms with a resolution of 0.25 ms. The setting for TL1 is based on the channel operating time plus the signal propagation time plus a margin of 1 millisecond. Thus if a power line carrier channel is used with an operating time of 2 milliseconds and the line is 186 miles long (propagation time = 1.0 ms), TL1 should be set with a 4 millisecond pickup time.





## CALCULATION OF SETTINGS

---

*Assume, for the example being used here, that the conditions in the previous paragraph apply. Therefore, set TL1 with a pickup time of 4 milliseconds, using the switches located on the board of the ULM222 module, Figure MO-14.*

## CONTACT CONVERTER VOLTAGE

The six voltage settings on the IOM112 module, Figure MO-7, found in location 2N should match the station battery DC voltage.

## SETTINGS LIST

A complete list of the settings to be made on the TYS system, and the modules that they are located on (See MODULES section for module location chart), is given in Settings List A on page CS-13. Blank spaces are left in this list so that it can be copied and used in listing the actual settings to be made in any given application. A completely filled out list for the settings determined in the worked example can be found in Settings List B on page CS-13.

CALCULATION OF SETTINGS

SETTINGS LIST B (*Worked Example*)

TYS3 PHASE DISTANCE AND GROUND DIRECTIONAL BLOCKING SCHEME SETTING LIST

<u>Module Location</u>	<u>Module</u>	<u>Adjustment</u>	<u>Description</u>	<u>Setting Location</u>	<u>Setting</u>
ZC	ABM11(-)	I1	Line PU supervision	on board	<u>0.6</u>
ZC	ABM11(-)	KV	Pos seq volt comp	on board	<u>0</u>
ZC	ABM11(-)	K	MB zero seq curr comp	on board	<u>2.2</u>
ZC	ABM11(-)	r	MB reach setting	front panel	<u>29</u>
ZG	ADM112	IM BIAS	Overcurrent supervision	on board	<u>0.05</u>
ZG	ADM112	IPB BIAS	Pilot blocking	on board	<u>0.05</u>
Y	AFM12(-)/13(-)	(r) ZR1	Zone 1 reach	front panel	<u>9.0Ω</u>
S	AFM12(-)	(r) ZRT	Overreaching reach	front panel	<u>27Ω</u>
ZJ	CTM12(-)	TD	TOC time dial	front panel	<u>2</u>
ZJ	CTM12(-)	TOC PU	TOC pickup	front panel	<u>0.05</u>
ZJ	CTM12(-)	DT PU	IDT pickup	front panel	<u>0.7</u>
ZJ	CTM12(-)	PT PU	IPT pickup	on board	<u>0.1</u>
ZJ	CTM12(-)	ITOC DIR CON	TOC directional control	on board	<u>IN</u>
ZJ	CTM12(-)	IDT DIR CON	IDT directional control	on board	<u>OUT</u>
P	ETM115	IØØ	MT overcurrent supervision	front panel	<u>0.1</u>
2N	IOM112	VDC	Contact conv. volt.	on board	<u>125</u>
ZA	ISM11(-)	∅Z <sub>1</sub>	Pos. seq. reach ang.	front panel	<u>85</u>
ZA	ISM11(-)	∅Z <sub>0</sub>	Zer. seq. reach ang.	front panel	<u>75</u>
K	ULM222	TL1	Trip integrator	on board	<u>4</u>
H	ULM233	TIMER II	Zone ( ) timer	front panel	<u>0.2</u>
H	ULM233	TIMER III	Zone ( ) timer	front panel	<u>0.3</u>
F	ULM256	OSB-1	OSB option	front panel	<u>OUT</u>
F	ULM256	OSB-2	OSB option	front panel	<u>IN</u>
M	UTM112	MT	MT char. timer	on board	<u>105°</u>
M	UTM112	MB	MB char. timer	on board	<u>95°</u>
M	UTM112	MOB	MOB char. timer	on board	<u>84°</u>
ZE	VMM11(-)	II	Zone 1 ext. factor	front panel	<u>1.4</u>

SETTINGS LIST A (Blank Example)

TYS3 PHASE DISTANCE AND GROUND DIRECTIONAL BLOCKING SCHEME SETTING LIST

<u>Module Location</u>	<u>Module</u>	<u>Adjustment</u>	<u>Description</u>	<u>Setting Location</u>	<u>Setting</u>
ZC	ABM11(-)	I1	Line PU supervision	on board	_____
ZC	ABM11(-)	KV	Pos seq volt comp	on board	_____
ZC	ABM11(-)	K	MB zero seq curr comp	on board	_____
ZC	ABM11(-)	r	MB reach setting	front panel	_____
ZG	ADM112	IM BIAS	Overcurrent supervision	on board	_____
ZG	ADM112	IPB BIAS	Pilot blocking	on board	_____
Y	AFM12(-)/13(-)	(r) ZR1	Zone 1 reach	front panel	_____
S	AFM12(-)	(r) ZRT	Overreaching reach	front panel	_____
ZJ	CTM12(-)	TD	TOC time dial	front panel	_____
ZJ	CTM12(-)	TOC PU	TOC pickup	front panel	_____
ZJ	CTM12(-)	DT PU	IDT pickup	front panel	_____
ZJ	CTM12(-)	PT PU	IPT pickup	on board	_____
ZJ	CTM12(-)	ITOC DIR CON	TOC directional control	on board	_____
ZJ	CTM12(-)	IDT DIR CON	IDT directional control	on board	_____
P	ETM115	IØØ	MT overcurrent supervision	front panel	_____
2N	IOM112	VDC	Contact conv. volt.	on board	_____
ZA	ISM11(-)	øZ <sub>1</sub>	Pos. seq. reach ang.	front panel	_____
ZA	ISM11(-)	øZ <sub>0</sub>	Zer. seq. reach ang.	front panel	_____
K	ULM222	TL1	Trip integrator	on board	_____
H	ULM233	TIMER II	Zone ( ) timer	front panel	_____
H	ULM233	TIMER III	Zone ( ) timer	front panel	_____
F	ULM256	OSB-1	OSB option	front panel	_____
F	ULM256	OSB-2	OSB option	front panel	_____
M	UTM112	MT	MT char. timer	on board	_____
M	UTM112	MB	MB char. timer	on board	_____
M	UTM112	MOB	MOB char. timer	on board	_____
ZE	VMM11(-)	II	Zone 1 ext. factor	front panel	_____



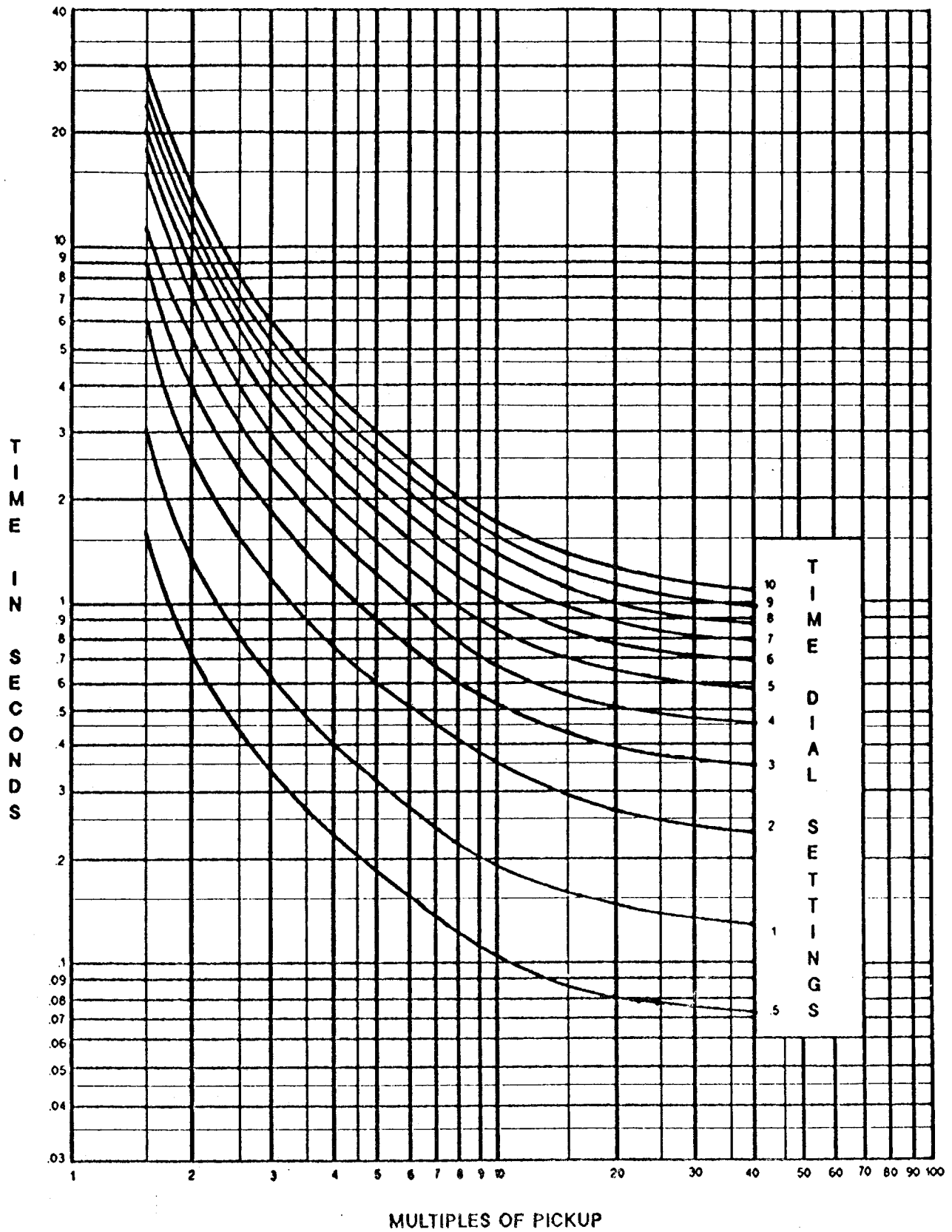

\* Figure CS-4 (0285A9858 [1]) Time Curve Characteristics

\* Revised since last issue



## HARDWARE DESCRIPTION

### CASE ASSEMBLY

#### Construction

The case that houses the electronic modules is constructed from an aluminum alloy. It consists of a main frame with side mounting brackets, a front cover and a rear cover.

The front cover, comprised of a metal frame with plate glass, is pivoted on the top and is opened from the bottom by way of two spring-loaded latches. The door is constrained from coming off by tabs that require the door to be unlatched and lifted slightly in order to be removed.

The rear cover supports terminal blocks that are used in making external connections to the case.

The modules are mounted vertically inside the case and they are supported by sockets within the case. In addition to this mechanical support, the sockets also offer the means of making the electrical connection to the modules. The modules are further restrained inside the case by the front cover.

Proper alignment of the module with respect to the socket is maintained by slotted guides, one guide above and one guide beneath each module, with the exception of the magnetics module, MGM, which requires two guides above and two beneath.

#### Electrical Connections and Internal Wiring

As mentioned earlier, electrical connections are made to the case through fourteen terminal blocks mounted on the rear cover plate. Each block contains 14 terminal points, which consist of a Number 6 screw threaded into a flat contact plate.

Connection to the printed-circuit board module is made by means of 60-pin edge connectors. Connection to the MGM module is made by means of two connector sockets; an 8-contact current block and a 104-pin signal block. The current block contacts are rated to handle current transformer (CT) secondary currents, and they are shorted upon removal of the MGM module.

#### Identification

The TYS system model number label is located on the outside of the front cover, and on the right-hand sidesheet inside the case.

A marking strip indicating the name and position of every module in a case is included on the middle shelf. It is placed to be read when the front cover is removed. Figure MO-1 in the MODULES section shows the location of the modules.

The terminal blocks located on the rear cover plate are uniquely identified by a two-letter code that is found directly beneath the outermost edge of each terminal block. Also, the terminal points (1 through 14) are identified by stamped numbers.

### PRINTED-CIRCUIT BOARD MODULES

#### Basic Construction

Each module consists of a printed-circuit board and front panel. Two knobs are provided on the front panel for removing and inserting the module. Electrical connection is made by the contact pads at the back edge of the board. Not all module locations within the case have a printed-circuit board; some locations have a blank board and a blank front panel.

HD

## Identification

Each module has its own identification number consisting of a three-letter code followed by a three-digit number. These are found at the bottom of each front panel and may be read when the front cover is removed.

## XTM TEST PLUGS

### Description

The XTM test plugs are designed specifically for post-installation testing of the TYS system. There are two plugs; XTM28L1 (left-hand plug) and XTM28R1 (right-hand plug), each providing access to fourteen relay-side and fourteen system-side points. The system-side points are designated "S" and the relay-side points are designated "R". The plugs are keyed by the contact finger arrangement so that there may be no accidental interchange between the left-hand and right-hand plugs.

The plugs are fitted with a sliding handle that swings out to facilitate wiring to the terminals. The terminals consist of number 8 screws threaded into flat contact plates. The handles each have a tab on the outside edge to guide the wire dress of the test leads.

### CAUTION

Not all external connections to the TYS are wired through the test receptacle.

### Terminal Designation

The test receptacle and connection plugs are located to the left of the magnetics module (extreme left-hand position). Their terminals are labeled 1 through 28, with 1 through 14 corresponding to the left-hand side and 15 through 28 corresponding to the right-hand side. These points are designated on the elementary diagram, Figure SD-5 as TP1 through TP28.

The left hand test plug (XTM28L1) terminals are labeled 1R through 14R and 1S through 14S for the relay side and system side, respectively, with the system side labeled in red. Similarly, the right hand test plug (XTM28R1) terminals are labeled 15R through 28R and 15S through 28S.

### XTM Test-Circuit Connections

Test-circuit connections, designated as TP points in the elementary diagrams, should be made to the relay side of the test plug. Where it is desired to use available system quantities for testing, e.g., DC control power, jumpers may be inserted between the corresponding system-side and relay-side test plug terminals. **Appropriate precautions should be taken when working with station battery DC.**

Connections should be made to the test plugs prior to insertion into the TYS.

### Test Plug Insertion

To insert the test plugs, the two connection plugs must first be removed. In so doing, electrical continuity is broken between the power system and the TYS for those signals that are wired through the test receptacle (refer to TP points on the elementary diagram, Figure SD-5 in the SCHEME DESCRIPTION section). For the terminals connected to the current-transformer secondaries, shorting bars are included on the system side of the test receptacle. These are clearly visible through the transparent plastic face plate on the receptacle. The shorting bars make contact before the connection-plug contacts break during removal, so that the CT secondaries are never open-circuited.

Both test plugs may be inserted at the same time. Otherwise, if using only one test plug, the connection plug may remain in the other half of the receptacle.

When the test plugs are inserted into the receptacle, parts of the power system

become isolated from the TYS. Refer to the elementary diagram for the TP points associated with each of the test plugs.

#### WARNING

IT IS CRITICAL THAT JUMPERS BE INSERTED ON THE SYSTEM-SIDE TEST PLUG TERMINALS THAT ARE CONNECTED TO THE CT SECONDARIES AS SHOWN IN FIGURE SD-5. IF THESE JUMPERS ARE LEFT OUT, THE RESULTING HIGH VOLTAGES DEVELOPED PRESENT A SERIOUS HAZARD TO PERSONNEL AND MAY SEVERELY DAMAGE EQUIPMENT.

#### CARD EXTENDER

The card extender (GE #0138B7406G1) is used to obtain information about the operation of an individual module. The extender may be inserted in the place of any of the printed-circuit modules. The module can then be inserted into the connector on the extender.

The extender has 60 test points, which are identified by numbers 1 through 60.

#### CAUTION

Remove power from the TYS before removing or inserting any of the printed-circuit board modules. Failure to observe this caution may result in damage to the relay.

To remove power, turn OFF the power switch on the PSM power supply module and then remove both of the TPM connection plugs located in the position to the left of the MGM module (see Figure MO-1).

#### WARNING

CAUTION MUST BE EXERCISED WHENEVER A CARD EXTENDER IS INSERTED INTO AN "IOM" OR "PSM" POSITION, SINCE STATION BATTERY POTENTIAL WILL BE PRESENT AT SOME POINTS. FAILURE TO OBSERVE THIS WARNING MAY RESULT IN PERSONAL INJURY OR DAMAGE TO THE EQUIPMENT. TURNING OFF THE POWER SWITCH ON THE PSM MODULE AND REMOVING BOTH CONNECTION PLUGS DOES NOT REMOVE ALL EXTERNAL POWER TO THE RELAY.

#### RECEIVING, HANDLING AND STORAGE

#### CAUTION

This relay contains electronic components that could be damaged by electrostatic discharge currents if those currents flow through certain terminals of the components. The main source of electrostatic discharge currents is the human body, and the conditions of low humidity, carpeted floors and isolating shoes are conducive to the generation of electrostatic discharge currents. Where these conditions exist, care should be exercised when removing and handling the modules to make settings on the internal switches. The persons handling the modules should make sure that their body charge has been discharged by touching some surface at ground potential before touching any of the components on the modules.

Immediately upon receipt, the equipment should be unpacked and examined for any damage sustained in transit. If damage resulting from rough handling is evident, file a damage claim at

HD



## HARDWARE DESCRIPTION

---

once with the transportation company and promptly notify the nearest GE Sales Office.

If the equipment is not to be installed immediately, it should be stored indoors in a location that is dry and protected from dust, metallic chips, and severe atmospheric conditions.

## INSTALLATION

### Environment

The location should be clean and dry, free from dust and excessive vibration, and well lighted to facilitate inspection and testing.

### Mounting

The TYS case has been designed for standard rack mounting. The case measures eight rack units (8 RU) in height. Refer to Figure HD-3 for the outline and mounting dimensions.

### External Connections

External connections are made according to the elementary diagram, Figure SD-5 in the SCHEME DESCRIPTION section. This is a general diagram incorporating all of the available options. Connection need not be made to those terminals associated with options that will not be used.

### External Connection Test

An overall check of current-transformer polarities, potential-transformer polarities, and connections to the TYS relay system can be made prior to placing the TYS in service, by using the system voltages and load current while monitoring the output of the NT directional unit. It should be noted that this test is a check of the external wiring and not a check of NT itself. It is assumed that the NT unit has been checked for

correct directional action per the test method given in the ACCEPTANCE TESTS section. The load current should be greater than 0.5 ampere secondary for this test.

### CAUTION

**During this test the trip circuits of the TYS should be disconnected to prevent inadvertent tripping of the circuit breaker.**

If the direction of power (KW) and reactive (KVAR) flow is away from the bus and into the protected line section, then use the XTM test-plug connections in Figure HD-4. These connections simulate an internal phase-A-to-ground fault by applying rated voltage to phase B and phase C and zero (0) voltage to phase A, while applying load current to phase A only. Check for an NT operation by observing a logic one (1) output at pin 18 of the test card extender inserted into the slot in location B at the top right of the unit. If the reactive flow is into the station bus, the resulting phase angle between load current and system voltage may be such that the NT unit will not operate.

If the direction of power and reactive flow is into the bus from the protected line section, then use the XTM test-plug connections in Figure HD-5. These connections reverse the phase A load current so that the NT unit will operate for this condition. If the reactive flow is away from the bus and into the protected line section, the resulting phase angle between load current and system voltage may be such that the NT unit will not operate.

---

**Surge Ground Connections****WARNING**

**TYS TERMINALS BH13 AND BH14 MUST BE TIED TOGETHER, AND TERMINAL BH14 MUST BE TIED TO THE GROUND BUS, AS SHOWN IN THE ELEMENTARY DIAGRAM, FIGURE SD-5. THE CONNECTION TO THE GROUND BUS MUST BE MADE USING A NO.12 WIRE OR LARGER. THE LEADS USED IN MAKING BOTH OF THESE CONNECTIONS SHOULD BE AS SHORT AS POSSIBLE.**

HD

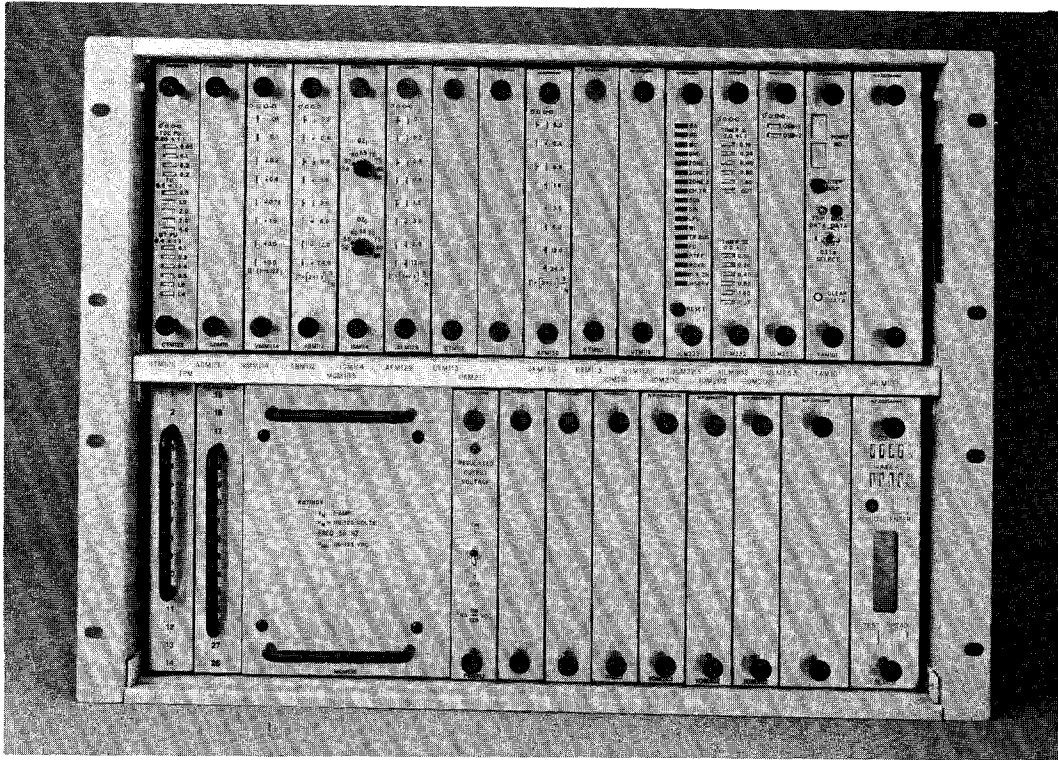

Figure HD-1 (8043781-1) TYS Relaying System, Front View

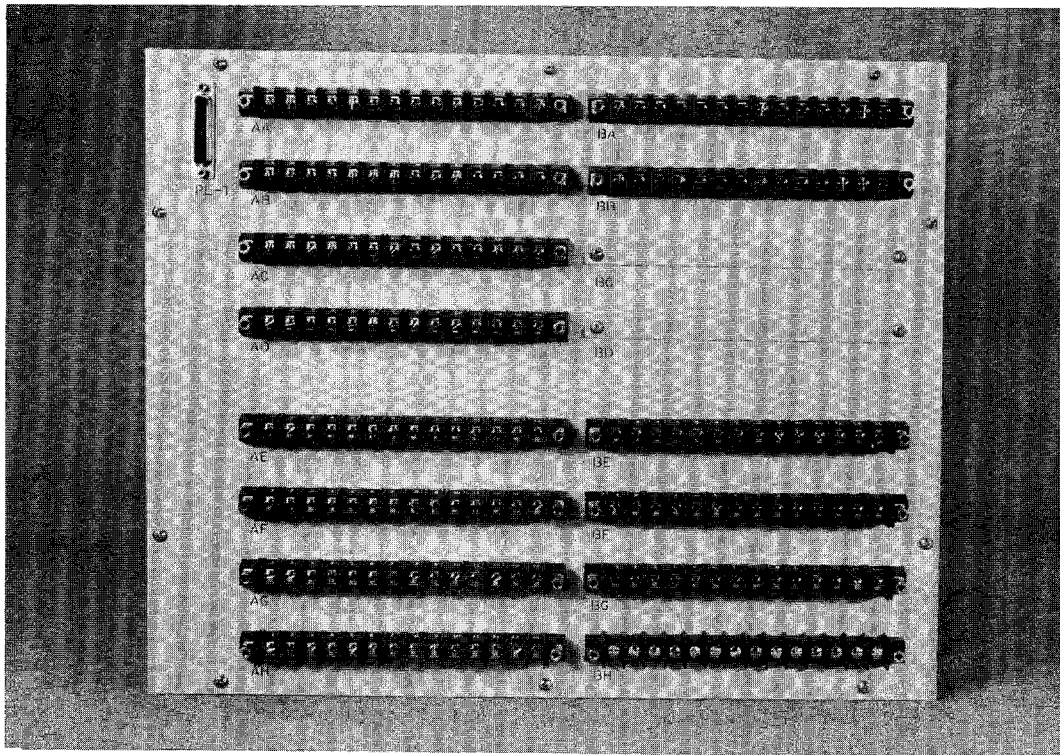

Figure HD-2 (8043782-1) TYS Relaying System, Rear View

HD

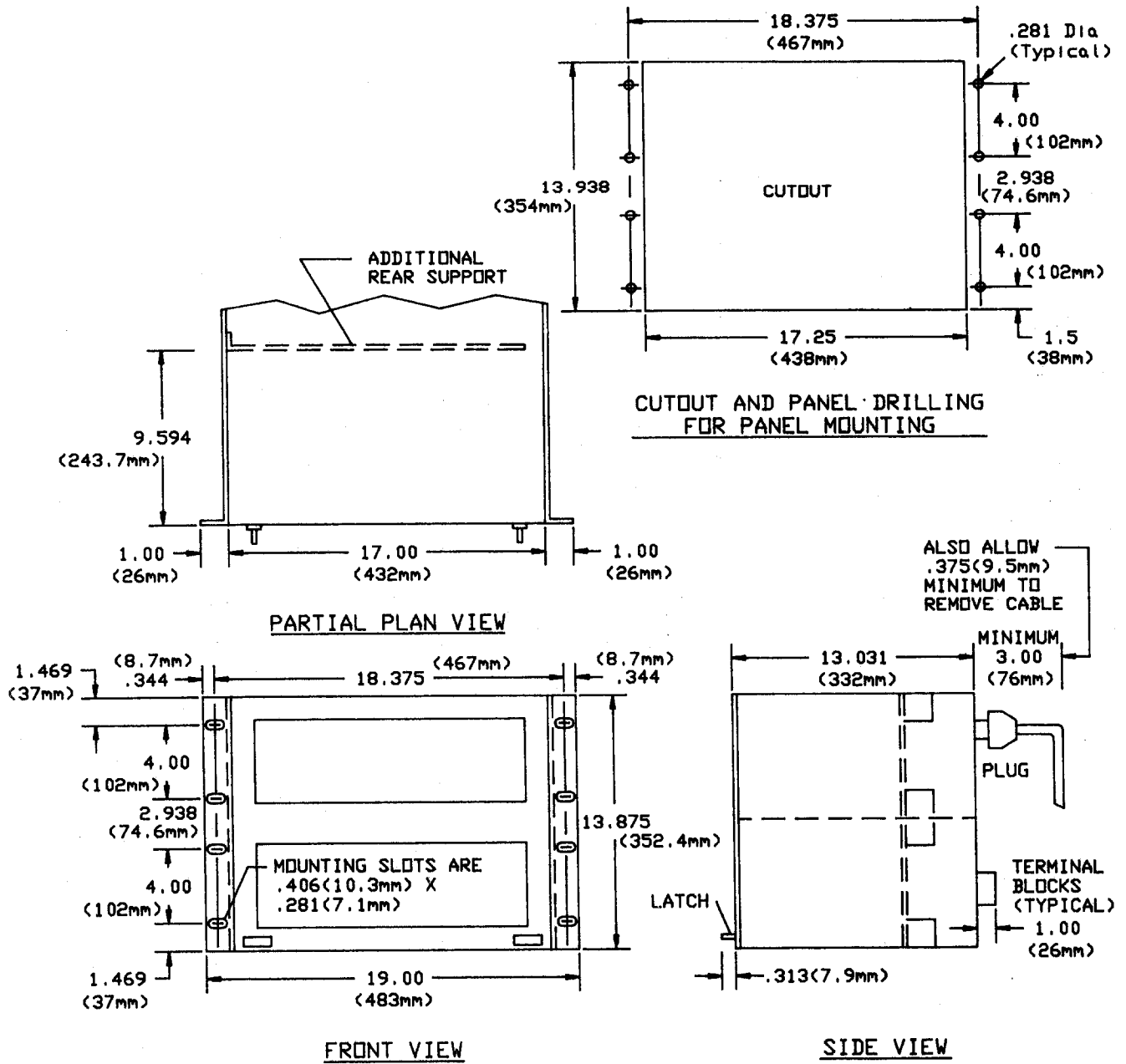

Figure HD-3 (0184B6393-1) Outline and Mounting Dimensions

(LEFT)  
XTM2BL1

FROM	TO
1S	1R
2S	2R
9S	9R
10S	10R
11S	12S
13S	14S

(RIGHT)  
XTM2BR1

FROM	TO
15S	15R
26S	26R
27S	27R
28S	28R

S - SYSTEM SIDE OF XTM TEST PLUG  
R - RELAY SIDE OF XTM TEST PLUG

CAUTION: CONNECTIONS BETWEEN POINTS  
9 THROUGH 14 MUST BE MADE BEFORE  
INSERTING THE XTM TEST PLUG TO  
PREVENT OPEN CIRCUITING THE CT  
SECONDARIES

Figure HD-4 (0286A2733) XTM Connections for External-Connection Test  
for KW and KVAR Away From Bus

(LEFT) XTM2BL1		(RIGHT) XTM2BR1	
FROM	TO	FROM	TO
1S	1R	15S	15R
2S	2R	26S	26R
9S	10R	27S	27R
10S	9R	28S	28R
11S	12S		
13S	14S		



S - SYSTEM SIDE OF XTM TEST PLUG  
 R - RELAY SIDE OF XTM TEST PLUG

CAUTION: CONNECTIONS BETWEEN POINTS  
 9 THROUGH 14 MUST BE MADE BEFORE  
 INSERTING THE XTM TEST PLUG TO  
 PREVENT OPEN CIRCUITING THE CT  
 SECONDARIES

Figure HD-5 (0286A2734) XTM Connections for External-Connection Test  
 for KW and KVAR Into Bus



# MODULES

		LOCATION																
		ZJ	ZG	ZE	ZC	ZA	Y	W	U	S	P	M	K	H	F	D	B	
<input type="checkbox"/>		<input type="checkbox"/>	<input type="checkbox"/>	<input type="checkbox"/>	<input type="checkbox"/>	<input type="checkbox"/>	<input type="checkbox"/>	<input type="checkbox"/>	<input type="checkbox"/>	<input type="checkbox"/>	<input type="checkbox"/>	<input type="checkbox"/>	<input type="checkbox"/>	<input type="checkbox"/>	<input type="checkbox"/>	<input type="checkbox"/>	<input type="checkbox"/>	
<input type="checkbox"/>	CTM 12-	<input type="checkbox"/>	<input type="checkbox"/>	<input type="checkbox"/>	<input type="checkbox"/>	<input type="checkbox"/>	<input type="checkbox"/>	<input type="checkbox"/>	<input type="checkbox"/>	<input type="checkbox"/>	<input type="checkbox"/>	<input type="checkbox"/>	<input type="checkbox"/>	<input type="checkbox"/>	<input type="checkbox"/>	<input type="checkbox"/>	<input type="checkbox"/>	
<input type="checkbox"/>	ADM 112	<input type="checkbox"/>	<input type="checkbox"/>	<input type="checkbox"/>	<input type="checkbox"/>	<input type="checkbox"/>	<input type="checkbox"/>	<input type="checkbox"/>	<input type="checkbox"/>	<input type="checkbox"/>	<input type="checkbox"/>	<input type="checkbox"/>	<input type="checkbox"/>	<input type="checkbox"/>	<input type="checkbox"/>	<input type="checkbox"/>	<input type="checkbox"/>	
<input type="checkbox"/>	VMM 11-	<input type="checkbox"/>	<input type="checkbox"/>	<input type="checkbox"/>	<input type="checkbox"/>	<input type="checkbox"/>	<input type="checkbox"/>	<input type="checkbox"/>	<input type="checkbox"/>	<input type="checkbox"/>	<input type="checkbox"/>	<input type="checkbox"/>	<input type="checkbox"/>	<input type="checkbox"/>	<input type="checkbox"/>	<input type="checkbox"/>	<input type="checkbox"/>	
<input type="checkbox"/>	ABM 11-	<input type="checkbox"/>	<input type="checkbox"/>	<input type="checkbox"/>	<input type="checkbox"/>	<input type="checkbox"/>	<input type="checkbox"/>	<input type="checkbox"/>	<input type="checkbox"/>	<input type="checkbox"/>	<input type="checkbox"/>	<input type="checkbox"/>	<input type="checkbox"/>	<input type="checkbox"/>	<input type="checkbox"/>	<input type="checkbox"/>	<input type="checkbox"/>	
<input type="checkbox"/>	ISM 11-	<input type="checkbox"/>	<input type="checkbox"/>	<input type="checkbox"/>	<input type="checkbox"/>	<input type="checkbox"/>	<input type="checkbox"/>	<input type="checkbox"/>	<input type="checkbox"/>	<input type="checkbox"/>	<input type="checkbox"/>	<input type="checkbox"/>	<input type="checkbox"/>	<input type="checkbox"/>	<input type="checkbox"/>	<input type="checkbox"/>	<input type="checkbox"/>	
<input type="checkbox"/>	AFM 1--	<input type="checkbox"/>	<input type="checkbox"/>	<input type="checkbox"/>	<input type="checkbox"/>	<input type="checkbox"/>	<input type="checkbox"/>	<input type="checkbox"/>	<input type="checkbox"/>	<input type="checkbox"/>	<input type="checkbox"/>	<input type="checkbox"/>	<input type="checkbox"/>	<input type="checkbox"/>	<input type="checkbox"/>	<input type="checkbox"/>	<input type="checkbox"/>	
<input type="checkbox"/>	ETM 113	<input type="checkbox"/>	<input type="checkbox"/>	<input type="checkbox"/>	<input type="checkbox"/>	<input type="checkbox"/>	<input type="checkbox"/>	<input type="checkbox"/>	<input type="checkbox"/>	<input type="checkbox"/>	<input type="checkbox"/>	<input type="checkbox"/>	<input type="checkbox"/>	<input type="checkbox"/>	<input type="checkbox"/>	<input type="checkbox"/>	<input type="checkbox"/>	
<input type="checkbox"/>	AFM 12-	<input type="checkbox"/>	<input type="checkbox"/>	<input type="checkbox"/>	<input type="checkbox"/>	<input type="checkbox"/>	<input type="checkbox"/>	<input type="checkbox"/>	<input type="checkbox"/>	<input type="checkbox"/>	<input type="checkbox"/>	<input type="checkbox"/>	<input type="checkbox"/>	<input type="checkbox"/>	<input type="checkbox"/>	<input type="checkbox"/>	<input type="checkbox"/>	
<input type="checkbox"/>	ETM 115	<input type="checkbox"/>	<input type="checkbox"/>	<input type="checkbox"/>	<input type="checkbox"/>	<input type="checkbox"/>	<input type="checkbox"/>	<input type="checkbox"/>	<input type="checkbox"/>	<input type="checkbox"/>	<input type="checkbox"/>	<input type="checkbox"/>	<input type="checkbox"/>	<input type="checkbox"/>	<input type="checkbox"/>	<input type="checkbox"/>	<input type="checkbox"/>	
<input type="checkbox"/>	UTM 112	<input type="checkbox"/>	<input type="checkbox"/>	<input type="checkbox"/>	<input type="checkbox"/>	<input type="checkbox"/>	<input type="checkbox"/>	<input type="checkbox"/>	<input type="checkbox"/>	<input type="checkbox"/>	<input type="checkbox"/>	<input type="checkbox"/>	<input type="checkbox"/>	<input type="checkbox"/>	<input type="checkbox"/>	<input type="checkbox"/>	<input type="checkbox"/>	
<input type="checkbox"/>	ULM 222	<input type="checkbox"/>	<input type="checkbox"/>	<input type="checkbox"/>	<input type="checkbox"/>	<input type="checkbox"/>	<input type="checkbox"/>	<input type="checkbox"/>	<input type="checkbox"/>	<input type="checkbox"/>	<input type="checkbox"/>	<input type="checkbox"/>	<input type="checkbox"/>	<input type="checkbox"/>	<input type="checkbox"/>	<input type="checkbox"/>	<input type="checkbox"/>	
<input type="checkbox"/>	ULM 233	<input type="checkbox"/>	<input type="checkbox"/>	<input type="checkbox"/>	<input type="checkbox"/>	<input type="checkbox"/>	<input type="checkbox"/>	<input type="checkbox"/>	<input type="checkbox"/>	<input type="checkbox"/>	<input type="checkbox"/>	<input type="checkbox"/>	<input type="checkbox"/>	<input type="checkbox"/>	<input type="checkbox"/>	<input type="checkbox"/>	<input type="checkbox"/>	
<input type="checkbox"/>	ULM 256	<input type="checkbox"/>	<input type="checkbox"/>	<input type="checkbox"/>	<input type="checkbox"/>	<input type="checkbox"/>	<input type="checkbox"/>	<input type="checkbox"/>	<input type="checkbox"/>	<input type="checkbox"/>	<input type="checkbox"/>	<input type="checkbox"/>	<input type="checkbox"/>	<input type="checkbox"/>	<input type="checkbox"/>	<input type="checkbox"/>	<input type="checkbox"/>	
<input type="checkbox"/>	*TAM 101	<input type="checkbox"/>	<input type="checkbox"/>	<input type="checkbox"/>	<input type="checkbox"/>	<input type="checkbox"/>	<input type="checkbox"/>	<input type="checkbox"/>	<input type="checkbox"/>	<input type="checkbox"/>	<input type="checkbox"/>	<input type="checkbox"/>	<input type="checkbox"/>	<input type="checkbox"/>	<input type="checkbox"/>	<input type="checkbox"/>	<input type="checkbox"/>	
<input type="checkbox"/>	*RLM 131	<input type="checkbox"/>	<input type="checkbox"/>	<input type="checkbox"/>	<input type="checkbox"/>	<input type="checkbox"/>	<input type="checkbox"/>	<input type="checkbox"/>	<input type="checkbox"/>	<input type="checkbox"/>	<input type="checkbox"/>	<input type="checkbox"/>	<input type="checkbox"/>	<input type="checkbox"/>	<input type="checkbox"/>	<input type="checkbox"/>	<input type="checkbox"/>	
1	15																<input type="checkbox"/>	2V
2	16																<input type="checkbox"/>	2T
3	17																<input type="checkbox"/>	2R
4	18																<input type="checkbox"/>	2N
5	19																<input type="checkbox"/>	2L
6	20																<input type="checkbox"/>	2J
7	21																<input type="checkbox"/>	2G
8	22																<input type="checkbox"/>	2E
9	23																<input type="checkbox"/>	2B
10	24																<input type="checkbox"/>	
11	25																<input type="checkbox"/>	
12	26																<input type="checkbox"/>	
13	27																<input type="checkbox"/>	
14	28																<input type="checkbox"/>	

\* - OPTIONAL MODULES

Figure MO-1 (0286A2850-1) Module Location  
Phase Distance and Ground Directional Blocking





# MODULES

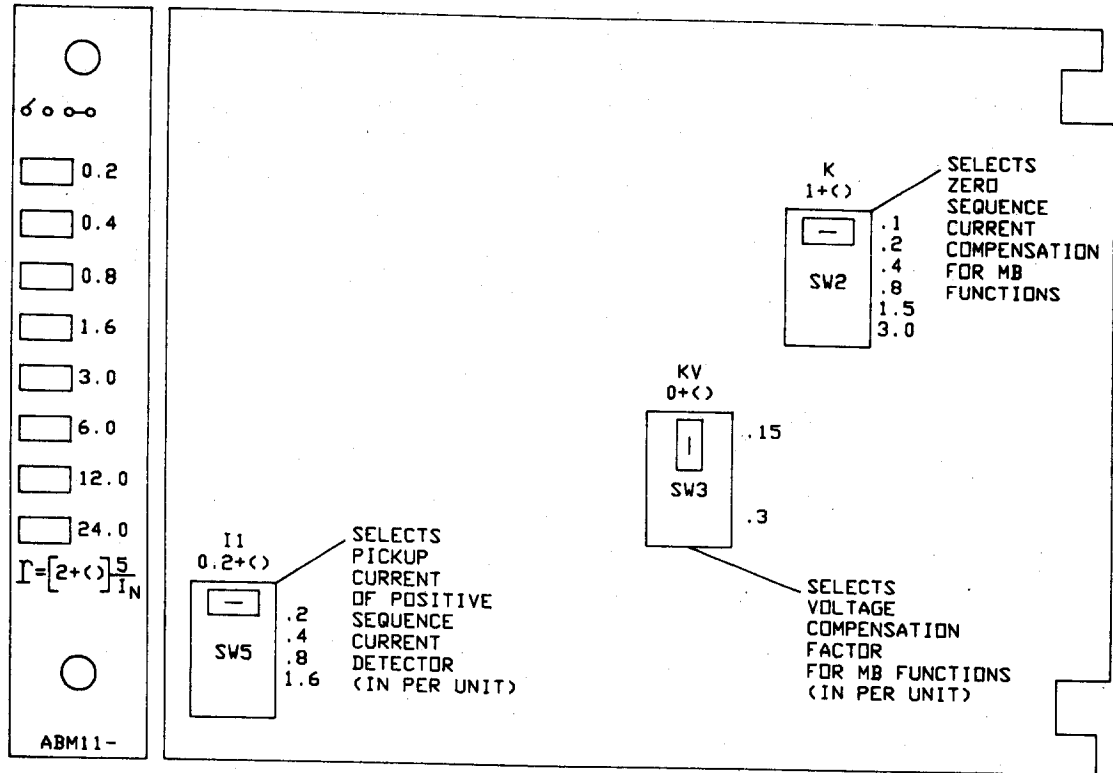
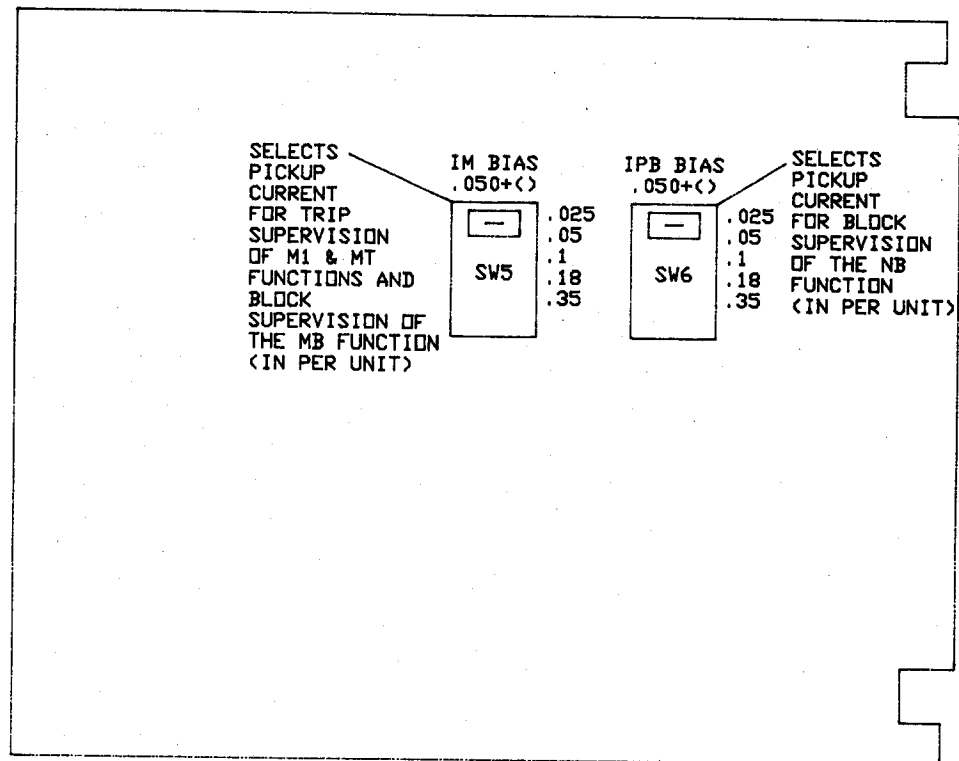
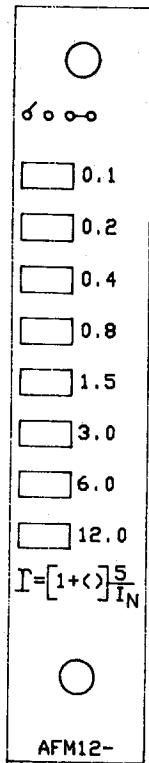

Figure MO-2 (0285A9972) Front Panel & Internal Switches, ABM11(-) Module



\* Figure MO-3 (0286A2829 [1]) Internal Switches, ADM112 Module

\* Revised since last issue



M1

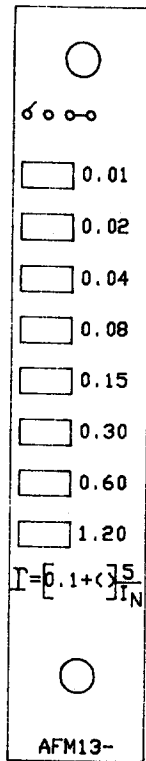

M1

SHORT REACH

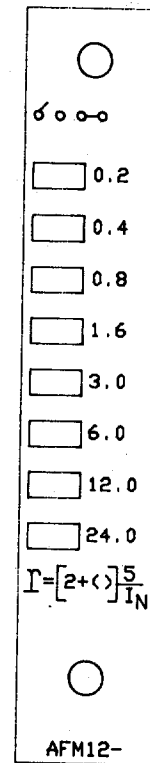

MT

Figure MO-4 (0285A9982-1) Front Panel, AFM12(-) and AFM13(-) Modules

Figure MO-5 (0285A9981-1) Front Panel, AFM12(-) Module

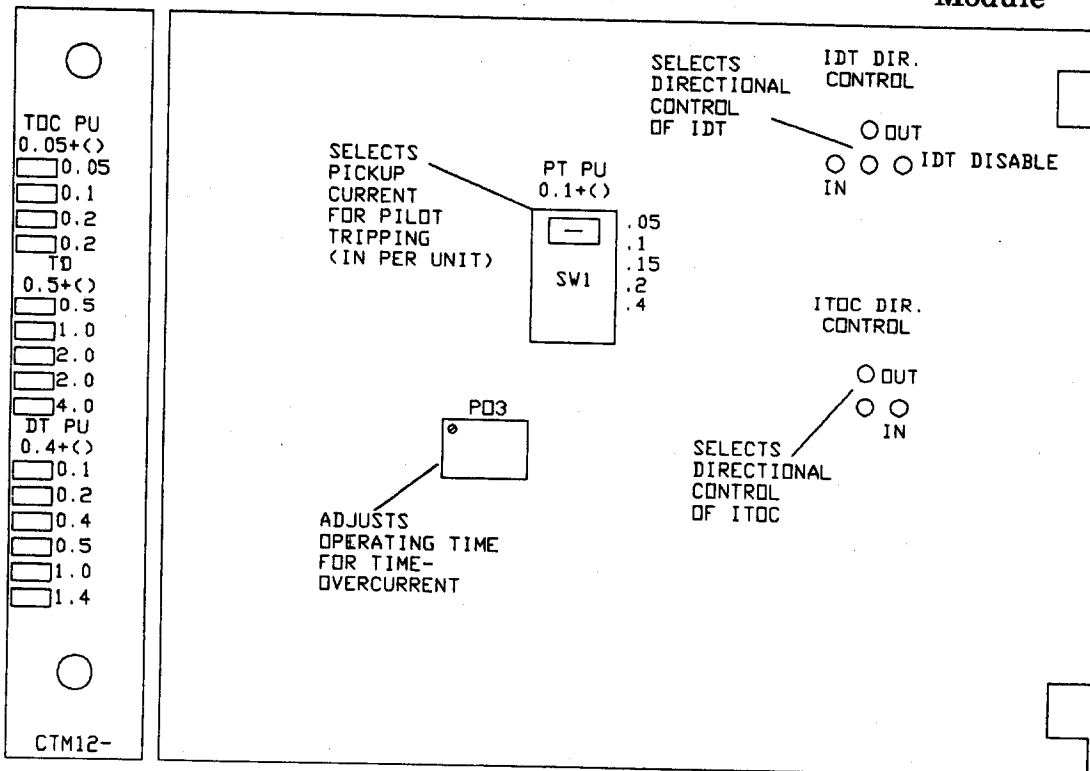

\* Figure MO-6 (0285A9974 [1]) Front Panel & Internal Switch & Links, CTM12(-) Module

\* Revised since last issue

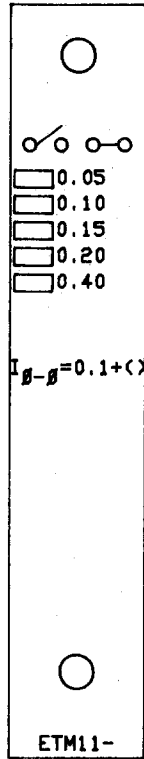

Figure MO-7 (0286A2830)  
Front Panel, ETM115  
Module

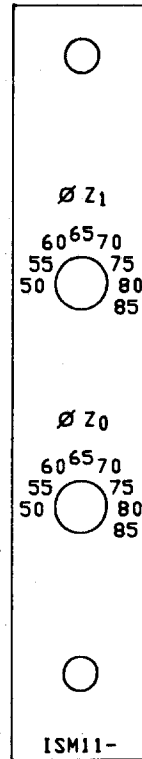

Figure MO-8 (0285A9980)  
Front Panel, ISM11(-)  
Module

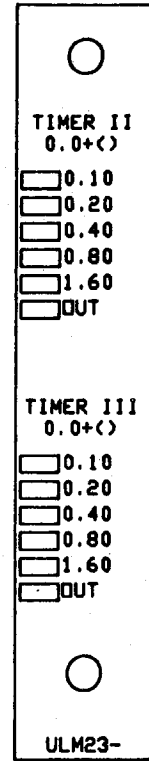

Figure MO-9 (0285A9983)  
Front Panel, ULM233  
Module

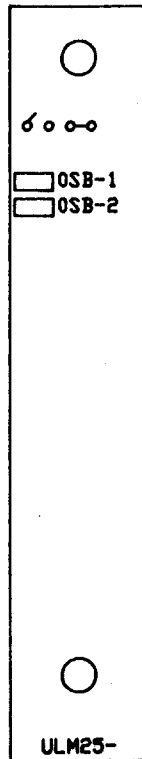

Figure MO-10 (0285A9984)  
Front Panel, ULM256  
Module

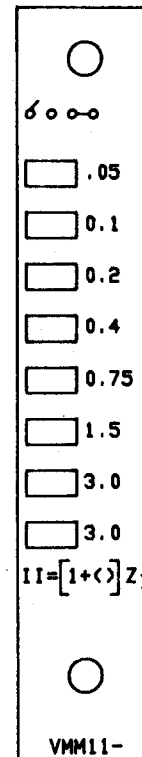

Figure MO-11 (0285A9979)  
Front Panel, VMM11(-)  
Module

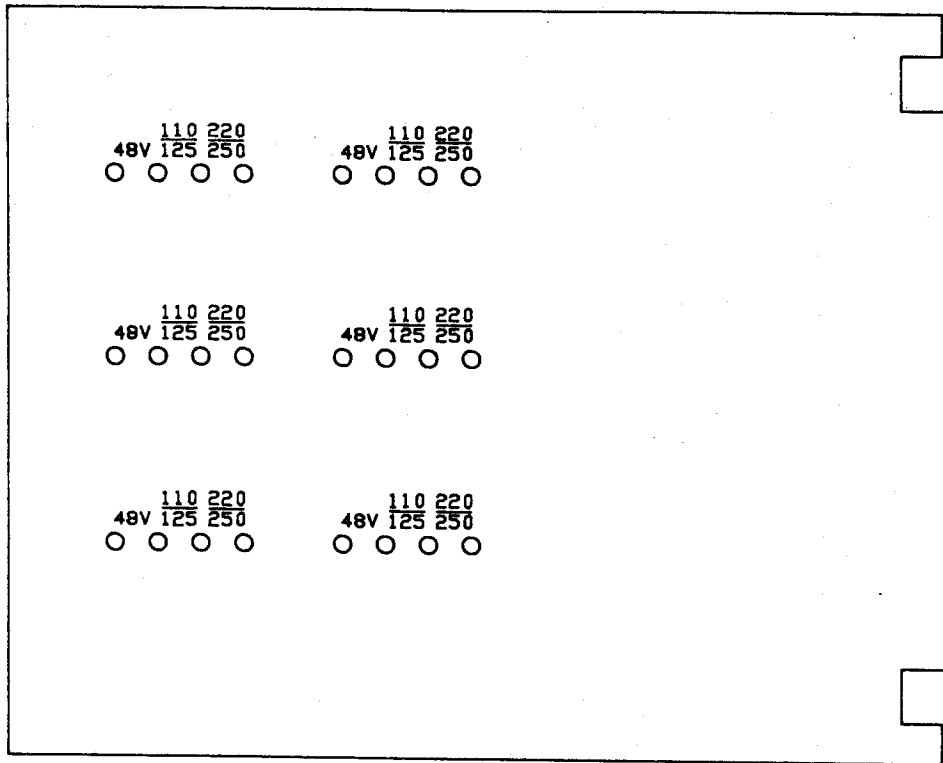

Figure MO-12 (0285A9975) Internal Links, IOM112 Module

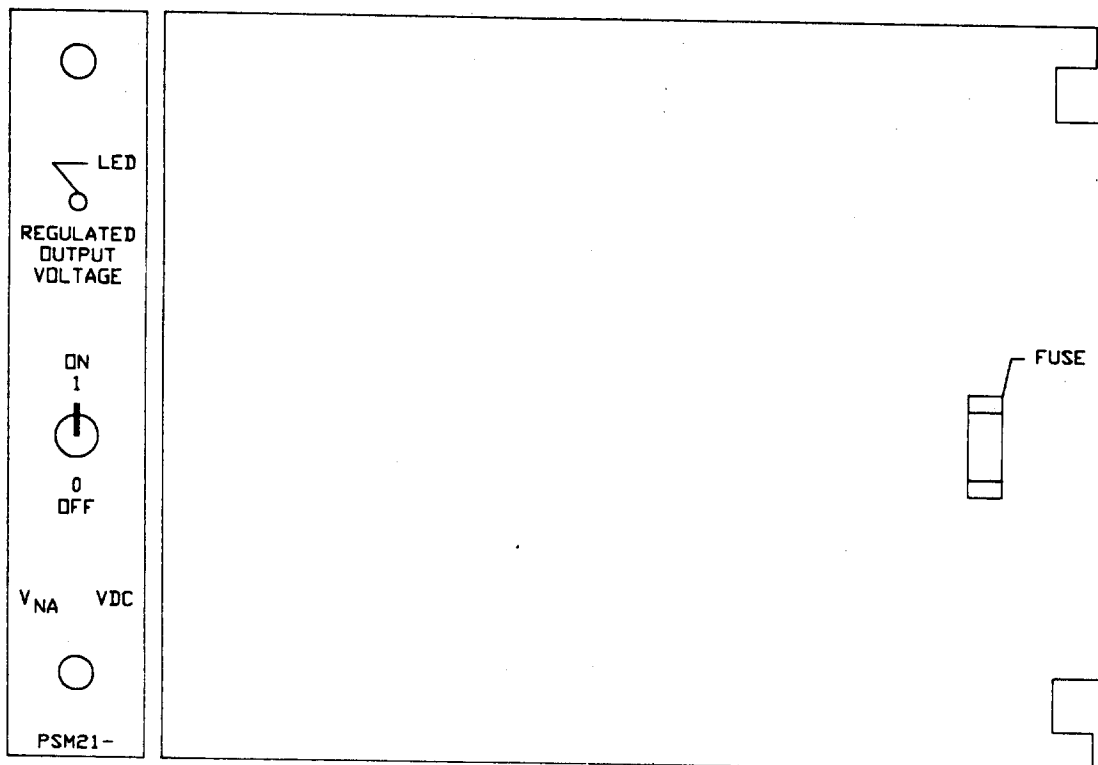

Figure MO-13 (0286A2547) Front Panel and Internal Fuse PSM21(-) Module

# MODULES

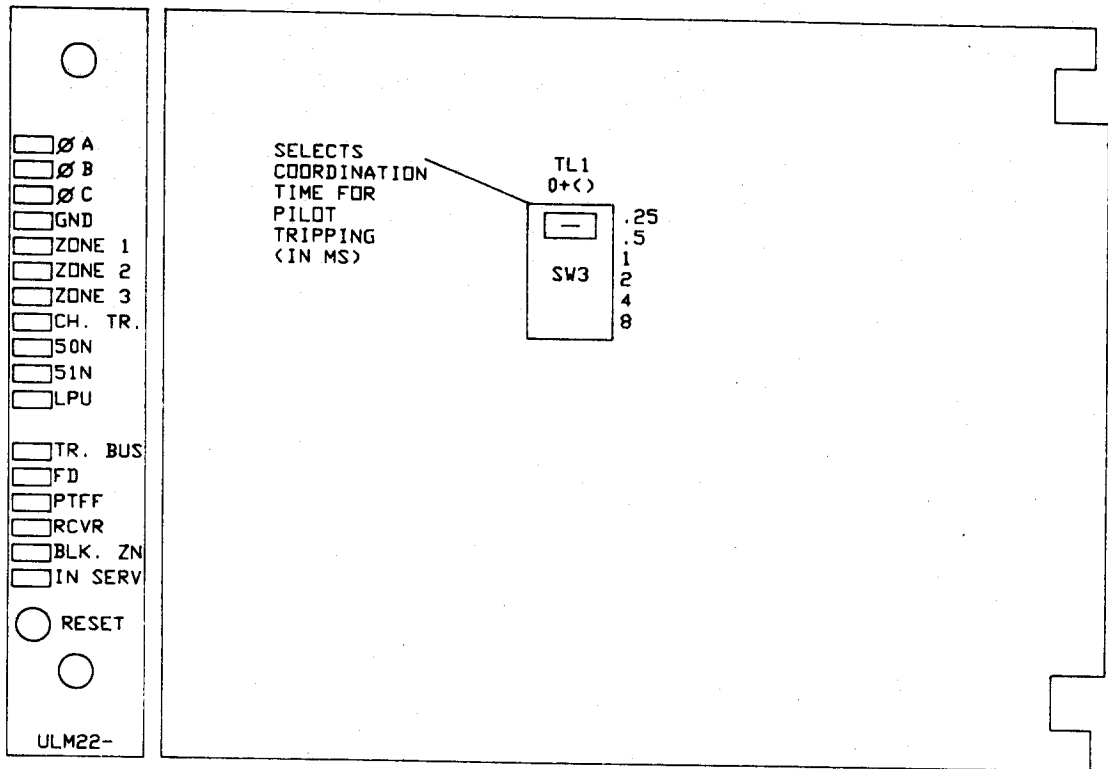

Figure MO-14 (0285A9976) Front Panel & Internal Switch, ULM222 Module

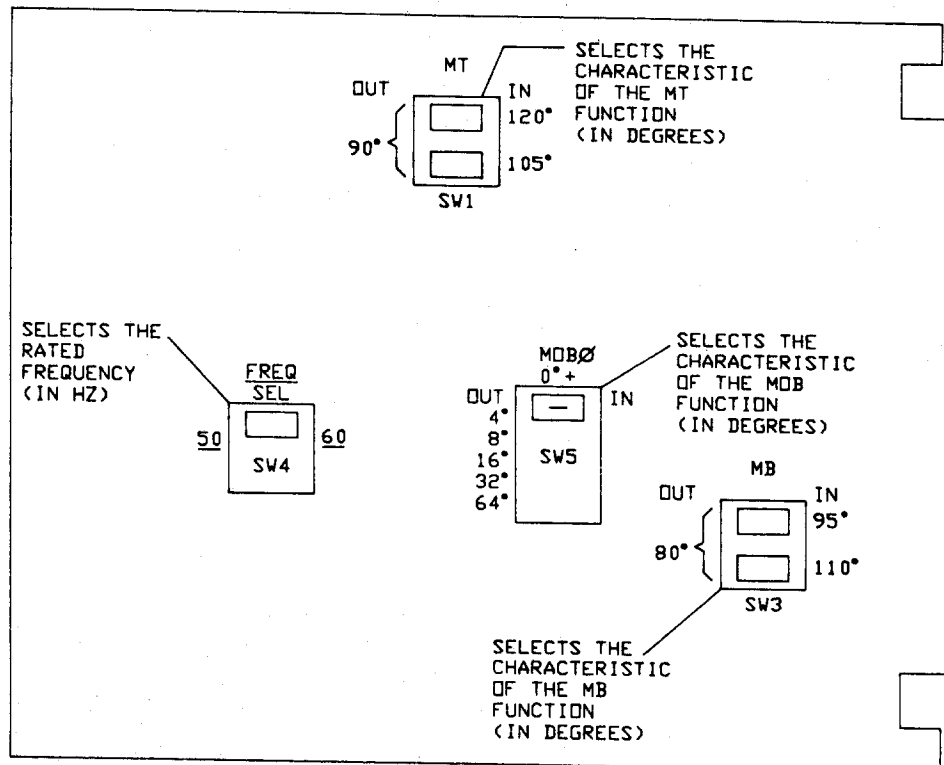

Figure MO-15 (0285A9977) Internal Switches, UTM112 Module

## ACCEPTANCE TESTS

The operational tests described in this section should be conducted prior to the installation of the TYS system. These may be done on a "bench-top" basis.

### CAUTION

Remove all power from the TYS before removing or inserting any of the printed-circuit board modules. Failure to observe this caution may result in damage to and/or misoperation of the relay.

To remove power, turn OFF the power switch on the PSM power supply module and then remove both of the connection plugs located in the TPM position (see Figure MO-1) (extreme caution is still required for inserting extender cards into the IOM or PSM positions).

### REQUIRED SETTINGS

To begin the acceptance tests, the module settings should be as indicated in Tables AT-I and AT-II. Remove the modules to gain access to the switches and/or links referred to in Table AT-I. The settings referred to in Table AT-II are located on the front panels of the respective modules. Module locations are shown in Figure MO-1.

Where there are different values for 5 ampere and 1 ampere relays, the value for the 1 ampere relay is given in parentheses after the 5 ampere relay value.

### TEST EQUIPMENT

The acceptance tests may be conducted in a conventional manner using the following test equipment:

- Three-phase source of voltage and current at rated frequency
- DC control voltage source
- Three AC voltmeters
- Three AC ammeters
- One oscilloscope
- One card extender  
(GE #0138B7406G1)
- One pair XTM test plugs  
(GE #XTM28R1 and XTM28L1)

The specific requirements for this equipment are given in the text of this ACCEPTANCE TESTS section, and in the associated test-circuit diagrams.

The three-phase AC sinusoidal voltage must be balanced and undistorted. Similarly, the DC power should come from a good DC source having less than 5% ripple.

As an alternative, a three-phase electronic test source may be used. In many cases, these devices enable the test circuits to be simplified considerably (see step 5).

### EQUIPMENT GROUNDING

All equipment used in testing the TYS relay should be connected to a common grounding point to provide noise immunity. This includes oscilloscopes, and current and voltage sources, as well as the TYS itself. NOTE: Terminal BH13 must be connected to terminal BH14, and BH14 must be connected to ground. The ground connections should be made with #12 or larger wire.



## ACCEPTANCE TESTS

TABLE AT-I

MODULE NAME	LOCATION	LINK/ SWITCH NAME	SETTINGS
ABM11(-)	ZC	K	(SWITCH) 1.0
		K <sub>v</sub>	(SWITCH) 0.3
		I <sub>1</sub>	(SWITCH) 0.2
ADM112	ZG	IPB BIAS	(SWITCH) 0.05
		IM BIAS	(SWITCH) 0.05
CTM12(-)	ZJ	IDT DIR. CONTROL	(LINK) "IN"
		ITOC DIR. CONTROL	(LINK) "IN"
		PT PU	(SWITCH) 0.5
IOM112	2N	DC PWR SUP SOURCE	(LINK) RATED
TAM101	D (OPTION)	LOGIC VOLT	(LINK) 12VDC
		SW4	(SWITCH) AS REQ'D
ULM222	K	TL1	(SWITCH) 0.0
UTM112	M	MT	(SWITCH) 90°
		MOB	(SWITCH) 124°
		MB	(SWITCH) 80°
		FREQ.	(SWITCH) RATED

### TEST CONNECTIONS

The test-circuit diagrams indicate not only TYS terminal numbers (rear cover terminals) but also the corresponding XTM test-plug terminal numbers. For the acceptance tests, the test connections should be made to the rear-cover terminals. The test plugs are intended for post-installation testing and are described in a separate subsection under **HARDWARE DESCRIPTION**.

### INITIAL RELAY SETTINGS

Place the internal links and/or switches on the modules in the appropriate positions to obtain the settings shown in Table AT-I.

Place the front-panel switches on the modules in the appropriate positions to obtain the settings listed in Table AT-II.

### GENERAL INSTRUCTIONS

1. Remove the upper-right blank module and insert a card extender (GE #0138B7406G1) in this location. The oscilloscope ground should be connected to pin 1 of this card for all tests.

Place the test source in rated-frequency position. Turn on the power supply and check that the green LED on the PSM21(-) module (see Figures MO-1 and MO-13) is lit. If the LED is not lit, refer to the **SERVICING** section.

2. The following tests are intended to verify the operation of the measuring units. If it is desired to check outputs or targets, refer to the logic diagram.
3. In the following tests, a LOW is defined as approximately 0 volt and a HIGH is defined as approximately 10 volts.

TABLE AT-II

MODULE NAME	LOCATION	SWITCH NAME	SETTING	RANGE
ABM11(-)	ZC	r	6.0	(2 TO 50 Ω)
AFM1(--)	S	r	3.0	(2 TO 50 Ω)
AFM12(-)	Y	r	3.0	(1 TO 25 Ω) †
AFM13(-)	OR Y	r	2.5	(0.1 TO 2.5 Ω) †
CTM12(-)	ZJ	TOC PU	0.6	(0.05 TO 0.6 PU)
		TD	1.0	(0.5 TO 10)
		DT PU	4.0	(0.4 TO 4.0 PU)
ETM115	P	I $\phi\phi$	0.1	(0.1 TO 1.0 PU)
ISM11(-)	ZA	$\phi Z_1$	85	(50 TO 85°)
		$\phi Z_0$	85	(50 TO 85°)
ULM233	H	TIMER II	0.0	(0 TO 3.1 SEC)
		TIMER III	0.0	(0 TO 3.1 SEC)
ULM256	F	OSB-1	OPEN	
		OSB-2	OPEN	
VMM11(-)	ZE	II	1.0	(1 TO 10) xZONE 1

† Refer to the specific model number and the Nomenclature Selection Guide (INTRODUCTION section) to determine which range has been supplied.

- Where two numbers are shown: xx(yy), xx is the value to be used for relays rated 5 amperes, and (yy) is the value to be used for relays rated 1 ampere.
- If the test source is an electronic type and one (or more) current source is not used for a particular test, that source must be set to "zero" in addition to being turned OFF. Also, these current sources should only be switched with the current set at, or near, zero (0).
- All phase angles of test sources are shown relative to phase A voltage. A (+) phase angle refers to the referenced-quantity leading phase A voltage. A (-) phase angle refers to the referenced-quantity lagging phase A voltage.

- All test voltages are phase-to-ground measurements, unless otherwise specified.

**\* CAUTION:**  
Use only a high-impedance digital voltmeter or an oscilloscope to perform these tests. Low-impedance meters or test devices may damage the relay.

## LEVEL-DETECTOR TESTS

### Fault-Detector Test

- Make the connections shown in Figure AT-1 with relay input Y connected to BH1 (TP9 for post-installation testing). Connect the

\* Revised since last issue





## ACCEPTANCE TESTS

---

oscilloscope input to card extender Pin 25. Set the oscilloscope for external trigger.

2. Set current  $I_{OP}$  to 0.5 (0.1) ampere rms. Close the pushbutton test switch for approximately one (1) second. When the pushbutton test switch opens, the oscilloscope trace should go HIGH momentarily, after which it should return to LOW.
3. Increase  $I_{OP}$  to 2.25 (0.45) amperes rms and repeat test 2. The oscilloscope trace should remain HIGH except when the pushbutton test switch is closed.

### IM Detector Test

1. With the connections as shown in Figure AT-1, move the oscilloscope input to card extender Pin 23. Increase  $I_{OP}$  until the oscilloscope trace goes from LOW to HIGH. At this point the current should be between 0.16 (0.032) and 0.201 (0.04) ampere rms.

### IPB Detector Test

1. With the connections as shown in Figure AT-1, move the oscilloscope input to card extender Pin 22. Increase  $I_{OP}$  until the oscilloscope trace goes from LOW to HIGH. At this point the current should be between 0.253 (0.05) and 0.308 (0.062) ampere rms.

### \* ITOC Detector Test (optional CTM12(-) required)

1. Set the "ITOC DIR. CONTROL" link, located on the CTM12(-) module, Figure MO-6, to the "OUT" position.
2. With the connections as shown in Figure AT-1, move the oscilloscope input to card extender Pin 28. Increase  $I_{OP}$  until the oscilloscope trace goes from LOW to HIGH. At

this point the current should be between 2.9 (0.59) and 3.3 (0.66) amperes rms.

3. Restore the "ITOC DIR. CONTROL" link to the "IN" position.

### \* IDT Detector Test (optional CTM12(-) required)

1. Using the "DT PU" switch located on the front panel of the CTM12(-) module, Figure MO-6, set the "IDT" function to 0.5 PU.
2. Set the "IDT DIR. CONTROL" link, located on the CTM12(-) module, Figure MO-6, to the "OUT" position.
3. With the connections as shown in Figure AT-1, move the oscilloscope input to card extender Pin 19. Increase  $I_{OP}$  until the oscilloscope trace goes from LOW to HIGH. At this point the current should be between 3.5 (0.70) and 3.9 (0.77) amperes rms.
4. Reset the "IDT" function to 4.0 PU and restore the "IDT DIR. CONTROL" link to the "IN" position.

### \* IPT Detector Test (optional CTM12(-) required)

1. With the connections as shown in Figure AT-1, move the oscilloscope input to card extender Pin 21. Place a temporary jumper between Pins 25 and 60 of the card extender.

**NOTE:** Pin 60 is connected to the +12VDC supply of the TYS.

2. Increase  $I_{OP}$  until the oscilloscope trace goes from LOW to HIGH. At this point the current should be between 2.72 (0.54) and 3.06 (0.61) amperes rms.
3. Remove the jumper between pins 25 and 60 of the card extender.

\* Revised since last issue

**I1 Detector Test**

1. With the connections as shown in Figure AT-1, move the oscilloscope input to card extender Pin 24. Increase  $I_{OP}$  until the oscilloscope trace goes from LOW to HIGH. At this point the current should be between 2.9 (0.59) and 3.3 (0.66) amperes rms.

**NB Test**

1. With the angle  $I_{OP}$  set to  $+95^\circ$ , move the oscilloscope input to card extender Pin 14. Reduce  $I_{OP}$  to 1.0 (0.2) amperes rms and check that the oscilloscope trace is HIGH.
2. Change angle  $I_{OP}$  to  $-85^\circ$  and check that the oscilloscope trace is LOW.

**V1 DETECTOR TEST**

1. With the connections as shown in Figure AT-2, move the oscilloscope input to card extender Pin 26. Set angle  $VA=0^\circ$ ,  $VB=-120^\circ$  and  $VC=+120^\circ$  or  $-240^\circ$ . Set voltage VA, VB and VC to 67 volts rms.
2. Reduce the three-phase voltage, simultaneously, until the oscilloscope trace goes from LOW to HIGH. At this point the voltage should be between 48.5 and 51.5 volts rms.

**M1 REACH TESTS**

1. With the connections as shown in Figure AT-4 for the appropriate phases and function to be tested, set angle  $VA=0^\circ$ ,  $VB=-120^\circ$  and  $VC=+120^\circ$  or  $-240^\circ$ . Set voltage VA, VB and VC to 67 volts rms. Set the phase angle of  $I_{OP}$  to the values indicated in Table AT-III (M1 with a range of 0.1 - 2.5  $\Omega$ ) or Table AT-IV (M1 with a range of 1 - 25  $\Omega$ ).

TABLE AT-III

Volts RMS	I Degrees
22 - 25	-25
27 - 31	-55
22 - 25	-85

**NEGATIVE-SEQUENCE DIRECTIONAL TESTS**

**NT Test**

1. With the connections as shown in Figure AT-3, move the oscilloscope input to card extender Pin 18. Connect the relay input "Y" to BH1 (TP9 for post-installation testing). Set angle  $VA=0^\circ$ ,  $VB=-120^\circ$  and  $VC=+120^\circ$  or  $-240^\circ$ . Set voltage VA, VB and VC to 67 volts rms.
2. Set angle  $I_{OP}=-85^\circ$ . Reduce voltage VA to 30 volts rms and slowly increase  $I_{OP}$  until the trace on the scope goes from LOW to HIGH. At this point current  $I_{OP}$  should be less than 1.0 ampere rms.
3. Change angle  $I_{OP}$  to  $+95^\circ$  and check that the oscilloscope trace does not go HIGH as  $I_{OP}$  is increased up to 10 (2) amperes rms.

TABLE AT-IV

Volts RMS	I Degrees
26 - 30	-25
32 - 37	-55
26 - 30	-85

2. Set  $I_{OP}$  to 10 (2) amperes rms. Simultaneously reduce the voltage of the faulted phases and check that the appropriate pin on the card extender goes from LOW to HIGH within the voltage limits given in Table AT-III (M1 with a range of 0.1 - 2.5  $\Omega$ ) or Table AT-IV (M1 with a range of 1 - 25  $\Omega$ ).

**MT REACH TESTS**

1. With the connections as shown in Figure AT-4 for the appropriate phases and function to be tested, set angle  $VA=0^\circ$ ,  $VB=-120^\circ$  and  $VC=+120^\circ$  or



## ACCEPTANCE TESTS

-240°. Set voltage VA, VB and VC to 67 volts rms. Set the phase angle of I<sub>OP</sub> to the values indicated in Table AT-V.

TABLE AT-V

Volts RMS	I Degrees
26 - 30	-25
32 - 37	-55
26 - 30	-85

- Set I<sub>OP</sub> to 10 (2) amperes rms. Simultaneously reduce the voltage of the faulted phases and check that the appropriate pin on the card extender goes from LOW to HIGH within the voltage limits given in Table AT-V.

## SWITCHED-ZONE TESTS

- Using the switches mounted on the front panel of the AFM12(-) or the AFM13(-) module, Figure MO-4, found in location "Y", set the M1 reach to 1.0.
- Using the switches mounted on the front panel of the VMM11(-) module, Figure MO-11, found in location "ZE", change the setting from 1.0 to 2.0.
- Using the switches mounted on the front panel of the ULM233 module, Figure MO-9, found in location "H", change the TIMER II setting from 0.0 to 1.6 and the TIMER III setting from 0.0 to "OUT".
- With the connections as shown in Figure AT-5 for the appropriate phases and function to be tested, set angle VA = 0°, VB = -120° and VC = +120° or -240°. Set voltage VA, VB and VC to 67 volts rms. Set the phase angle of I<sub>OP</sub> to the values indicated in Table AT-VI.
- Close the CC1 switch and set I<sub>OP</sub> to 10 (2) amperes rms. Simultaneously reduce the voltage of the faulted phases and check that the

TABLE AT-VI

Volts RMS	I Degrees
26 - 30	-25
32 - 37	-55
26 - 30	-85

appropriate MT pin on the card extender goes from LOW to HIGH within the voltage limits given in Table AT-VI.

- Slowly continue to reduce the voltage of the faulted phases. Check that the appropriate M1 pin on the card extender goes from LOW to HIGH within the voltage limits given in Table AT-VII. Also, check that the "ZONE 2" LED, located on the front panel of the ULM222 module, Figure MO-14, found in location "K", is lit.

TABLE AT-VII

Volts RMS	I Degrees
17 - 20	-25
21 - 25	-55
17 - 20	-85

- Open the CC1 switch and reset all switches mentioned in steps 1 through 3 to their pre-test positions.

## MB TESTS

- With the connections as shown in Figure AT-3 for the appropriate phase to be tested, set angle VA = 0°, VB = -120° and VC = +120° or -240°. Set voltage VA, VB and VC to 67 volts rms. Set the phase angle of I<sub>OP</sub> to the values indicated in Table AT-VIII.

TABLE AT-VIII

Volts RMS	I Degrees
50 - 58	+65
52 - 60	+95
50 - 58	+125

2. Set  $I_{OP}$  to 5 (1) amperes rms. Simultaneously, reduce the three-phase voltage and check that the appropriate pin on the card extender goes from LOW to HIGH within the voltage limits given in Table AT-VIII.
6. Reset the MOB timer to its pre-test position.

## MOB TESTS

1. Change the MOB timer setting to  $60^\circ$ . This is accomplished by means of a switch located on the UTM112 module, Figure MO-15, which is found in location "M".
2. With the connections as shown in Figure AT-6, connect the oscilloscope input to card extender Pin 27. Set angle  $V_A = 0^\circ$ ,  $V_B = -120^\circ$  and  $V_C = +120^\circ$  or  $-240^\circ$ . Set voltage  $V_A$ ,  $V_B$  and  $V_C$  to 67 volts rms. Set the phase angle of  $I_{OP}$  to the values indicated in Table AT-IX.

TABLE AT-IX

Volts RMS	I Degrees
35 - 41	-25
35 - 41	-85

3. Set  $I_{OP}$  to 10 (2) amperes rms. Simultaneously reduce the voltage of the faulted phases until the trace on the oscilloscope, Pin 27, goes from LOW to HIGH (First Pulse) within the voltage limits given in Table AT-IX. Move the oscilloscope input to card extender Pin 45 and check that it also has changed from LOW to HIGH.
4. Connect the oscilloscope input to card extender Pin 8, 9 or 10, determined by the phases that are being tested. Continue to reduce the voltage of the faulted phases until the trace on the oscilloscope goes from LOW to HIGH. Also, check that the trace on the oscilloscope from card extender Pin 45 remained HIGH.
5. Increase the voltage of the faulted phases back to 67 volts rms and check that the trace on the oscilloscope from card extender Pin 45 returned to a LOW.

AT

ACCEPTANCE TESTS

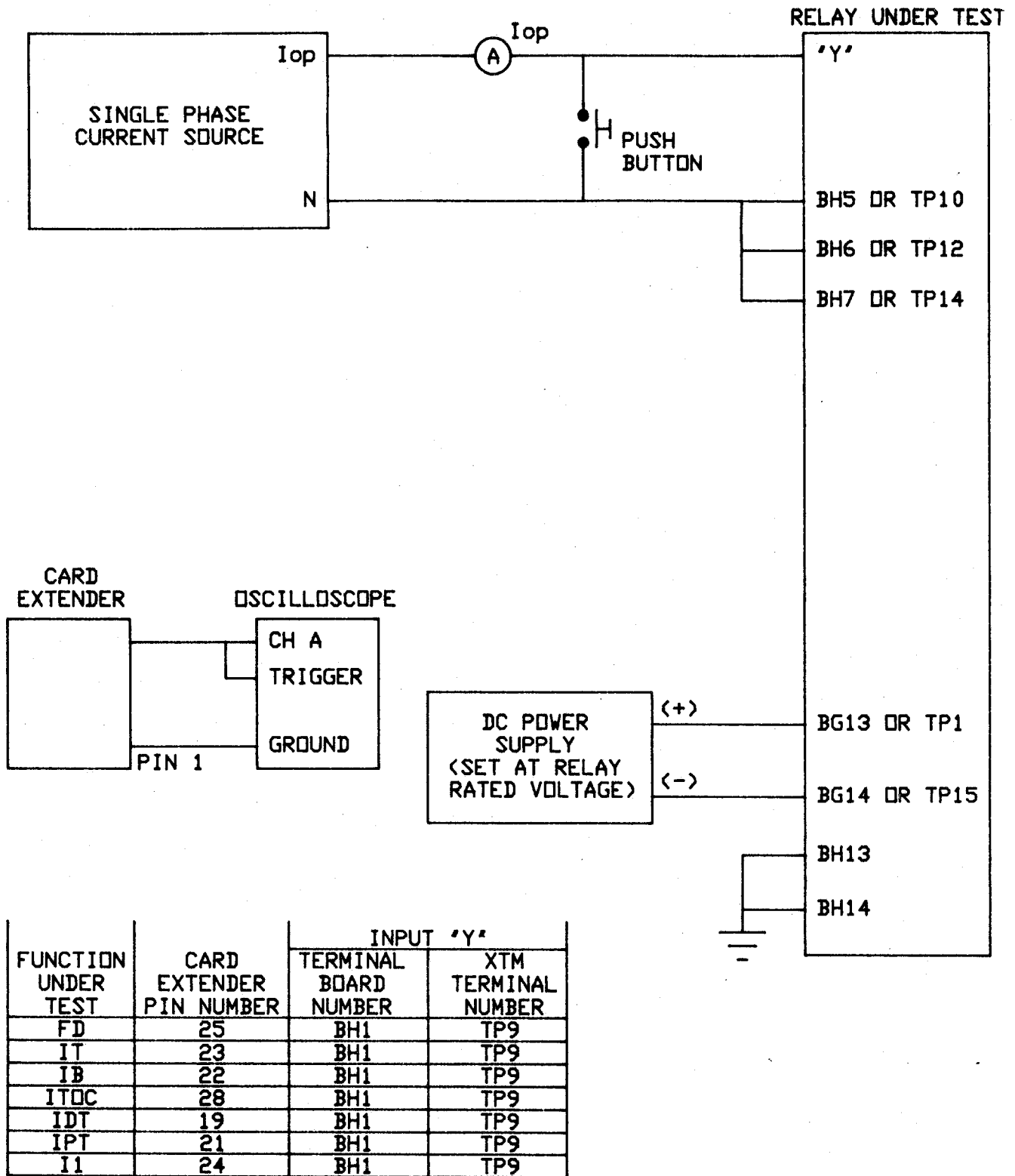
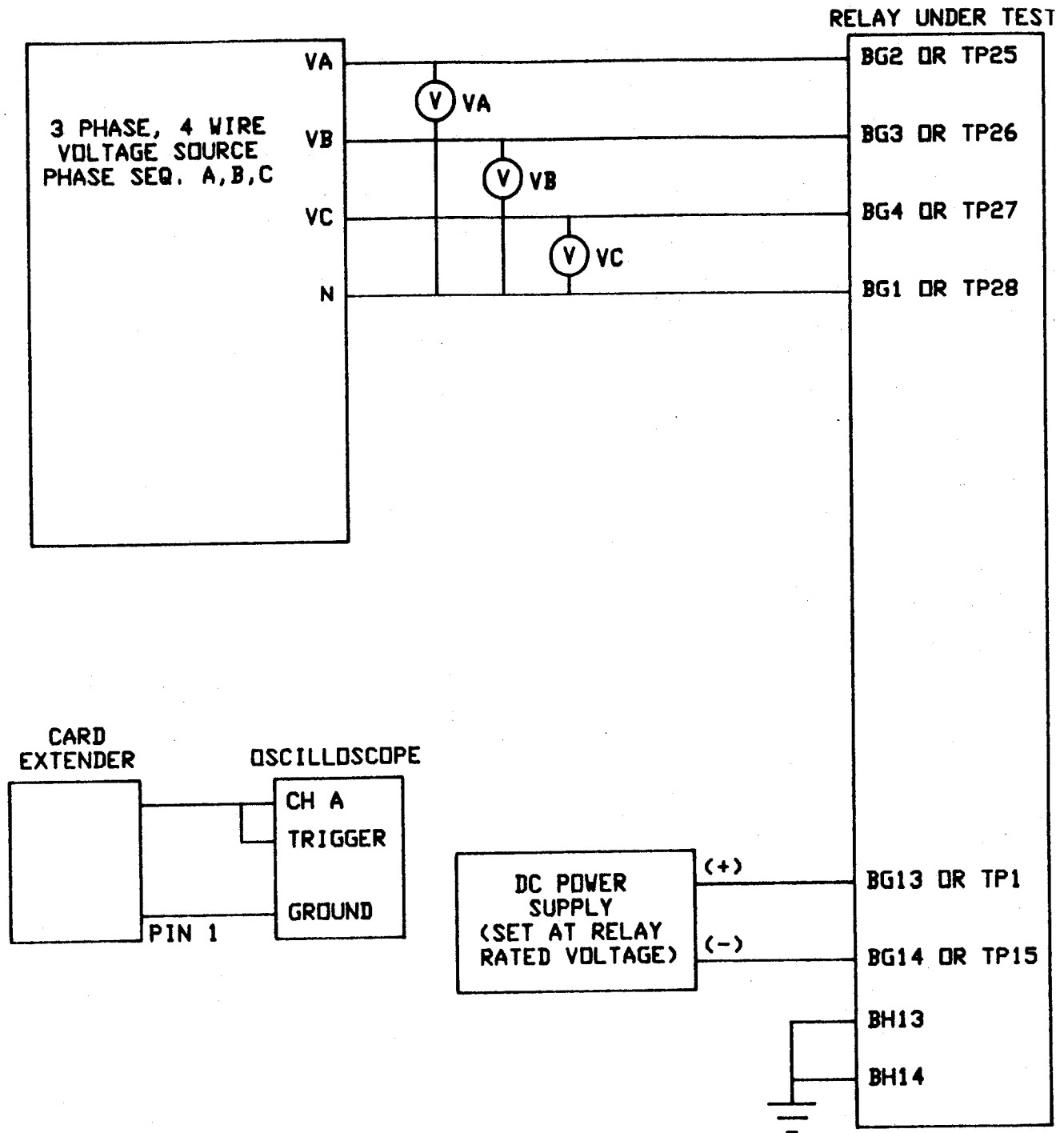

Figure AT-1 (0286A2813) Level-Detector Test Connections



\* Figure AT-2 (0286A2519-2) V1 Test Connections

\* Revised since last issue

ACCEPTANCE TESTS

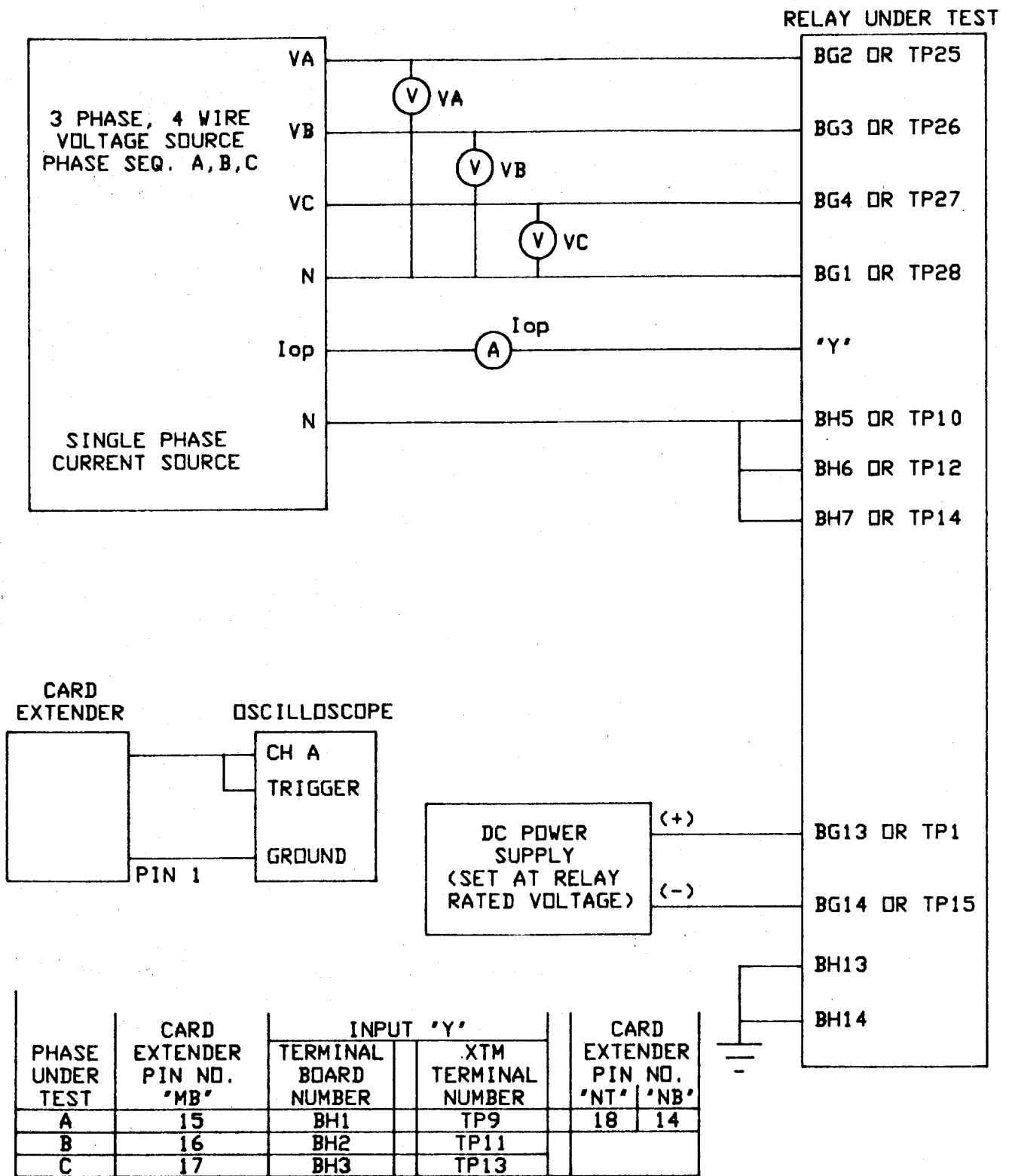

Figure AT-3 (0286A2518-1) Negative-Sequence Directional Test and MB Function Test Connections

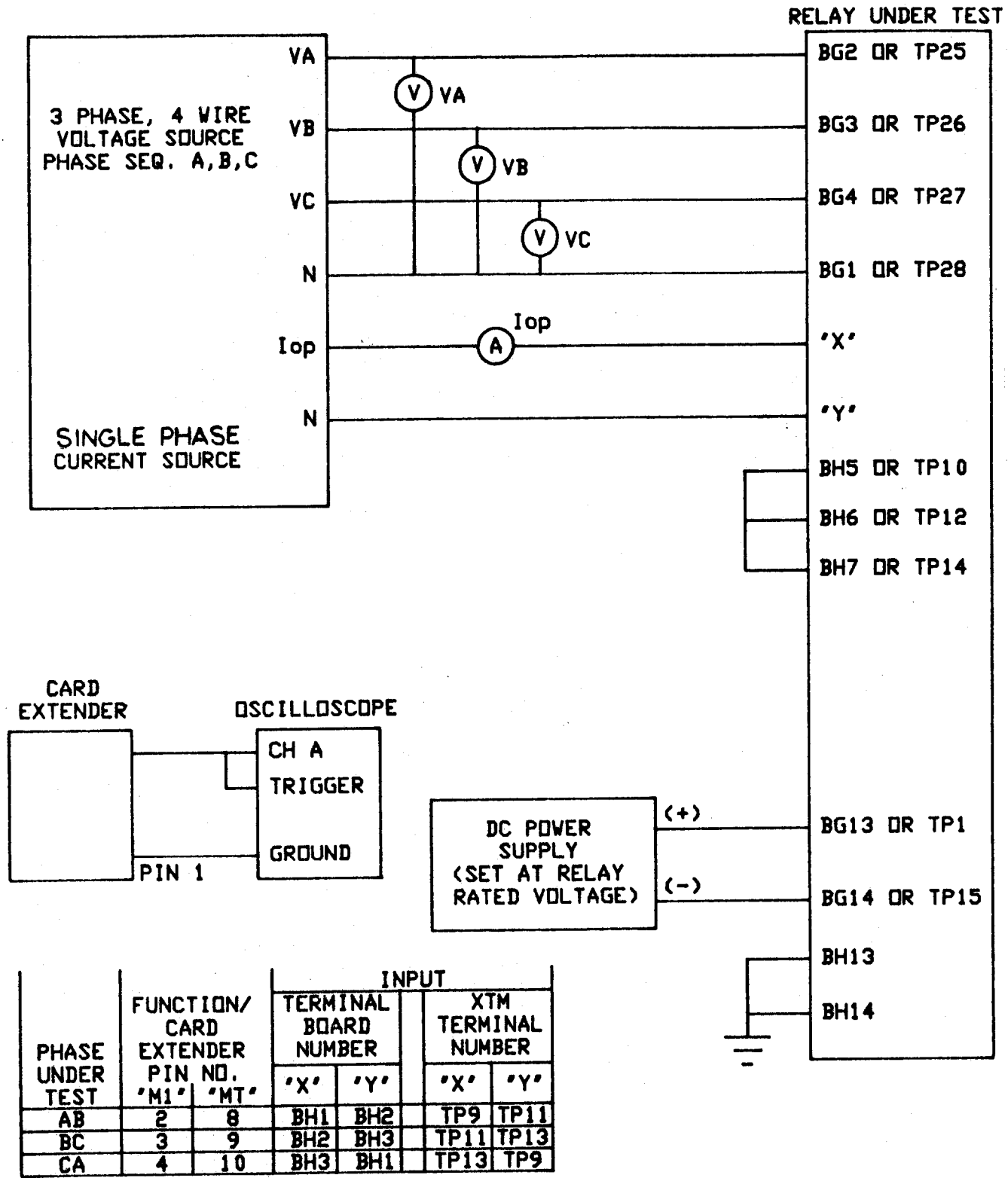

Figure AT-4 (0286A2516-2) M1 and MT Reach Test Connections



# ACCEPTANCE TESTS

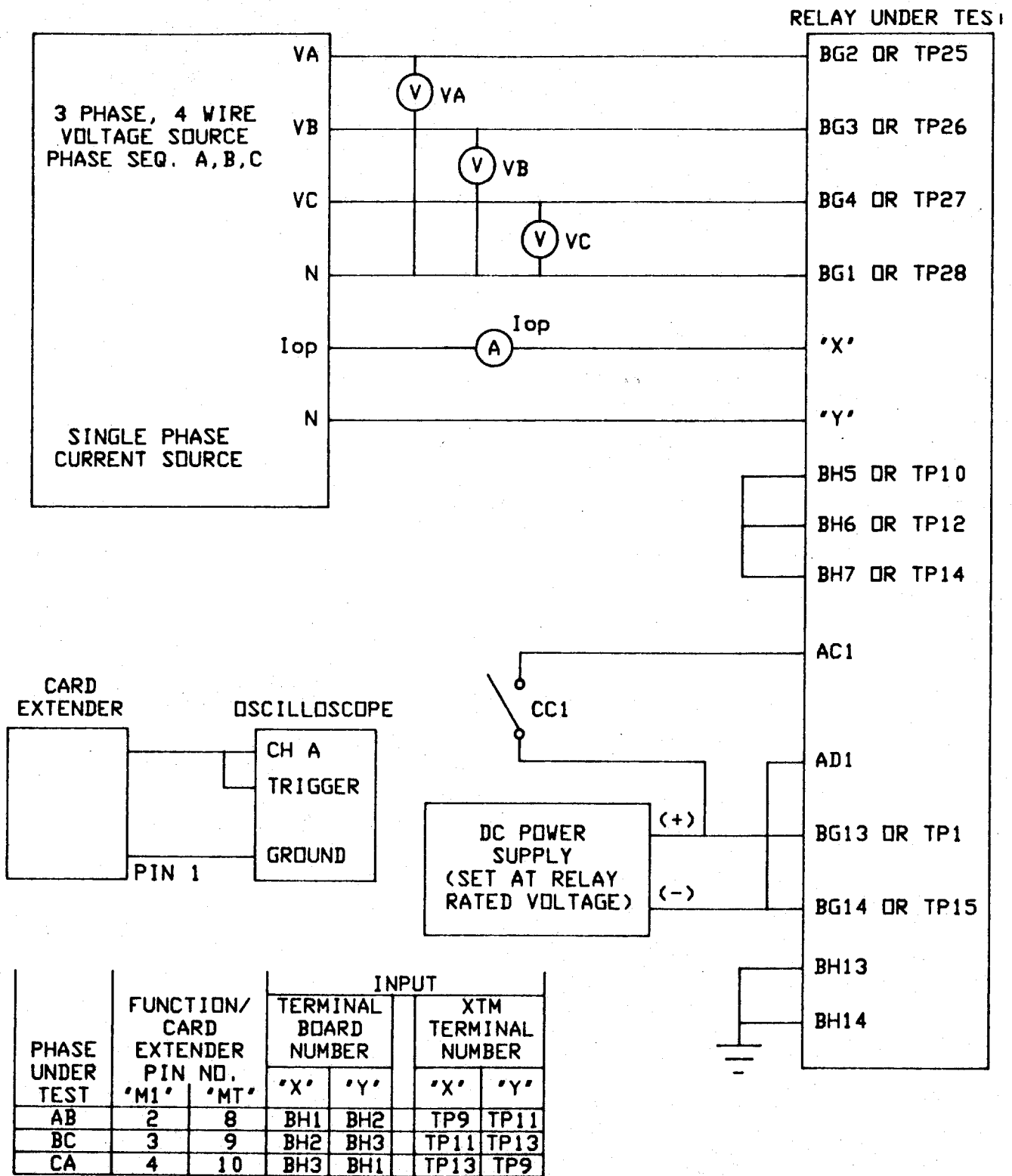

Figure AT-5 (0286A2517-1) Switched-Zone Test Connections

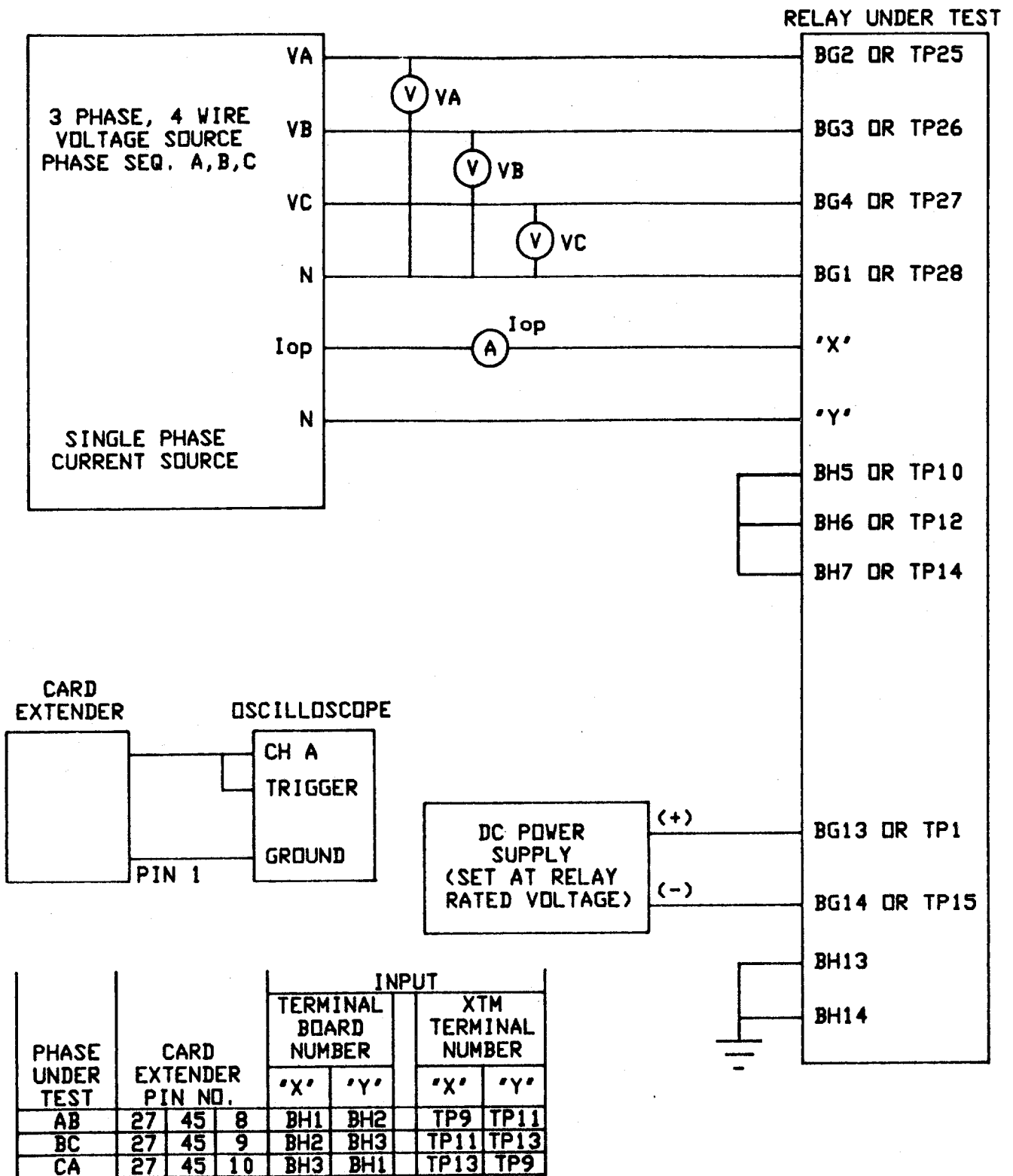

Figure AT-6 (0286A2515-1) MOB Test Connections



## PERIODIC TESTING

### TESTING THE TYS WITH USER SETTINGS

The formulas presented below will permit the calculation of the pickup currents and voltages for testing of the TYS using settings specific to a particular application. The test circuits to be used are the same as those used (and illustrated) in the ACCEPTANCE TEST section of this book.

The tests given below are the only tests required for periodic testing.

### TOLERANCE

The tolerances on the pickup values calculated for the TYS functions are dependent on the magnitude of the test current, as listed in Table PT-I.

TABLE PT-I

I <sub>TEST</sub> in RMS Amperes I <sub>N</sub> = 5	I <sub>N</sub> = 1	Tolerance in Percent	
		Minimum	Maximum
0 - 1	0 - 0.2	0	+15
1 - 3	0.2 - 0.6	-2	+10
3 - 7	0.6 - 1.4	-3	+ 7
> 7†	> 1.4†	-5	+ 5

† **NOTE** The relay is continuously rated for 2 x I<sub>N</sub> amperes rms. For test currents greater than the continuous rating, testing should be conducted with a duty cycle. For example, with a test current of 4 x I<sub>N</sub> amperes, the current should not be applied longer than 5 minutes, followed by a cooling-off period of 5 minutes

### CURRENT-LEVEL DETECTORS

#### IM

Use the connections shown in Figure AT-1 for testing IM. Slowly increase the current, I<sub>OP</sub>, until the oscilloscope trace goes from LOW to HIGH. The nominal pickup current is given by Equation 1. The actual pickup current (I) should be ± 0.015 PU current, or within the tolerance given in Table PT-I for the particular value of test current, whichever is greater.

$$I = ("IM \text{ BIAS}" \text{ PU} - .015) \times I_N \quad (1)$$

WHERE:

- "IM BIAS" PU is the per-unit setting on the ADM112 module, Figure MO-3
- I<sub>N</sub> is the rated relay current (1 or 5 amperes)
- I is the nominal pickup current

#### IPB

Use the connections shown in Figure AT-1 for testing IPB. Slowly increase the current, I<sub>OP</sub>, until the oscilloscope trace goes from LOW to HIGH. The nominal pickup current is given by Equation 2. The actual pickup current should be ± 0.015 PU current, or within the tolerance given in Table PT-I for the particular value of test current, whichever is greater.

$$I = \frac{"IPB \text{ BIAS}" \text{ PU} \times I_N}{(1 - "IPB" \text{ KB})} \quad (2)$$

WHERE:

- "IPB BIAS" PU is the per-unit setting on the ADM112 module, Figure MO-3
- I<sub>N</sub> is the rated relay current (1 or 5 amperes)
- I is the nominal pickup current
- "IPB" KB is the I<sub>1</sub> restraint factor (factory set to 0.066)

PT

## PERIODIC TESTING

### \* ITOC (optional CTM12(-) module required)

Set the "ITOC DIR. CONTROL" link, located on the CTM12(-) module, Figure MO-6, to the "OUT" position.

Use the connections shown in Figure AT-1 for testing ITOC. Slowly increase the current,  $I_{OP}$ , until the oscilloscope trace goes from LOW to HIGH. The nominal pickup current is given by Equation 3. The actual pickup current should be within the tolerance given in Table PT-I for the particular value of test current.

Restore the "ITOC DIR. CONTROL" link to its pre-test position.

$$I = \text{"TOC" PU} \times I_N \quad (3)$$

#### WHERE:

"TOC" PU is the per-unit setting on the CTM12(-) module, Figure MO-6

$I_N$  is the rated relay current (1 or 5 amperes)

$I$  is the nominal pickup current

### \* TOC Time Verification (optional CTM12(-) module required)

Connect the relay as shown in Figure PT-1. Set the timer to start upon application of current, and to stop on a contact closure. The timer will start when current is applied, and stop when the trip contact closes. This current value ( $I_{op}$ ) is a multiple of the pickup value determined by equation 3. The pickup time should follow the very-inverse time curve, Figure CS-4, within  $\pm 5\%$ , for the time-dial setting on the front panel of the CTM12(-) module.

#### Example:

If the TOC pickup is set to 0.2 and the nominal current is 5 amperes, then the TOC function should pick up at approximately 1.0 amperes rms. If a multiple of pickup of 2.0 is selected, the  $I_{op}$  should be set to 2.0 amperes rms. When a

\* Revised since last issue

time-dial setting is selected, such as 5, the pickup time will be 6.45 seconds  $\pm 5\%$ .

All times should be within 5% of the published very-inverse time curve, figure CS-4, found in the CALCULATION OF SETTINGS section. If the times are out of calibration, it will be necessary to adjust potentiometer PO3 on the CTM12(-) module, found in Figure MO-6. Adjust this potentiometer to obtain times within 5% of the published very-inverse curve. For more accurate calibration, it is recommended that the multiple of pickup be set to 1.60 seconds  $\pm 5\%$ . These settings are used in factory calibration.

NOTE: If either the magnetics module, MGM, or the time-overcurrent module (CTM12(-)) must be replaced, it will be necessary to repeat the above test to assure proper time-overcurrent calibration.

### \* IDT (optional CTM12(-) module required)

Set the "IDT DIR. CONTROL" link, located on the CTM12(-) module, Figure MO-6, to the "OUT" position.

Use the connections shown in Figure AT-1 for testing IDT. Slowly increase the current,  $I_{OP}$ , until the oscilloscope trace goes from LOW to HIGH. The nominal pickup current is given by Equation 4. The actual pickup current should be within the tolerance given in Table PT-I for the particular value of test current.

Restore the "IDT DIR. CONTROL" link to its pre-test position.

$$I = \frac{\text{"IDT" PU} \times I_N}{(1 - \text{"IDT" K1})} \quad (4)$$

#### WHERE:

"IDT" PU is the per-unit setting on the CTM12(-) module, Figure MO-6

"IDT" K1 is the I1-restraint factor. (Factory set to 0.3)

$I_N$  is the rated relay current

(1 or 5 amperes)  
I is the nominal pickup current

**\* IPT (optional CTM12(-) module required)**

Place a temporary jumper between Pins 25 and 60 of the card extender.

**NOTE:** Pin 60 is connected to the +12VDC supply of the TYS.

Use the connections shown in Figure AT-1 for testing IPT. Slowly increase the current, I<sub>OP</sub>, until the oscilloscope trace goes from LOW to HIGH. The nominal pickup current is given by Equation 5. The actual pickup current should be within the tolerance given in Table PT-I for the particular value of test current.

Remove the jumper between pins 25 and 60 of the card extender.

$$I = \frac{\text{"IPT" PU} \times I_N}{(1 - \text{"IPT" KT})} \quad (5)$$

**WHERE:**

"IPT" PU is the per unit setting on the CTM12(-) module, Figure MO-6  
"IPT" KT is the I1 restraint factor. (Factory set to 0.1)  
I<sub>N</sub> is the rated relay current (1 or 5 amperes)  
I is the nominal pickup current

**I1**

Use the connections shown in Figure AT-1 for testing I1. Slowly increase the current, I<sub>OP</sub>, until the oscilloscope trace goes from LOW to HIGH. The nominal pickup current is given by Equation 6. The actual pickup current should be within the tolerance given in Table PT-I for the particular value of test current.

$$I = \text{"I1" PU} \times I_N \times 3 \quad (6)$$

Revised since last issue

**WHERE:**

"I1" PU is the per-unit setting on the ABM11(-) module, Figure MO-2  
I<sub>N</sub> is the rated relay current (1 or 5 amperes)  
I is the nominal pickup current

**FD**

The fault detector may be tested using the same method as specified under ACCEPTANCE TESTING since there are no customer settings on this function.

**REACH TESTS**

**M1**

Use the connections shown in Figure AT-4 for the appropriate phases and function to be tested.

Set the current and voltage phase angles per Table PT-II.

**TABLE PT-II**

Phase AB	I <sub>OP</sub>	-(Θ - 30)°
Phase BC	I <sub>OP</sub>	-(Θ + 90)°
Phase CA	I <sub>OP</sub>	(150 - Θ)°
V <sub>A</sub>		0°
V <sub>B</sub>		-120°
V <sub>C</sub>		+120°

Where: Θ is the setting of "ϕZ<sub>1</sub>" on the ISM11(-) module, Figure MO-8

The recommended test currents for this test are given in Table PT-III.

The nominal operating voltage for "M1", at the angle of maximum reach, is given in Equation 7.

$$V_{NOM} = \frac{Z_{R1} \times 2 \times I_{TEST}}{\sqrt{3}} \quad (7)$$

**WHERE:**

V<sub>NOM</sub> is the phase-to-ground pickup voltage  
I<sub>TEST</sub> is the test current  
Z<sub>R1</sub> is the nameplate reach



setting "r" on the front panel of the AFM12(-)/13(-) module, Figure MO-4, found in location "Y"

TABLE PT-III

$I_N = 5$		$I_{TEST}(amps)$
$Z_{R1}$ or "r"( $\Omega$ )		
0.1 -	2.5†	10
1 -	6	10
6 -	12	5
12 -	20	3
20 -	25	2
$I_N = 1$		$I_{TEST}(amps)$
$Z_{R1}$ or "r"( $\Omega$ )		
0.5 -	12.5†	2
5 -	30	2
30 -	60	1
60 -	100	0.6
100 -	125	0.4

† = "Z<sub>R1</sub>" SHORT REACH

**NOTE:** The switch marked "II" mounted on the front panel of the VMM11(-) module, Figure MO-11, should be set to total 1 when testing the "M1" function.

The applied three-phase voltage should be initially set to a value greater than the nominal operating voltage and the current should be increased slowly to the recommended test value. The voltage of the faulted phases should be slowly lowered, simultaneously, until the trace on the oscilloscope steps from LOW to HIGH. The actual operating voltage should be within the tolerances given in Table PT-I for the value of test current used.

To check the "M1" function at other angles, refer to the TYSTEST computer program provided in the SOFTWARE section of this manual.

**MT**

Use the connections shown in Figure AT-4 for the appropriate phases and function to be tested.

Set the current and voltage phase angles per Table PT-II.

The recommended test currents for this test are given in Table PT-IV.

TABLE PT-IV

$I_N = 5$		$I_{TEST}(amps)$
$Z_{RT}$ or "r"( $\Omega$ )		
2 -	6	10
6 -	12	5
12 -	20	3
20 -	30	2
30 -	40	1.5
40 -	50	1.0
$I_N = 1$		$I_{TEST}(amps)$
$Z_{RT}$ or "r"( $\Omega$ )		
10 -	30	2
30 -	60	1
60 -	100	0.6
100 -	150	0.4
150 -	200	0.3
200 -	250	0.2

The nominal operating voltage for "MT", at the angle of maximum reach, is given in Equation 8.

$$V_{NOM} = \frac{Z_{RT} \times 2 \times I_{TEST}}{\sqrt{3}} \quad (8)$$

WHERE:

- $V_{NOM}$  is the phase-to-ground pickup voltage
- $I_{TEST}$  is the test current
- $Z_{RT}$  is the reach setting "r" on the front panel of the AFM12(-) module, Figure MO-5, found in location "S".

The applied three-phase voltage should be initially set to a value greater than the nominal operating voltage and the current should be increased slowly to the recommended test value. The voltage of the faulted phases should be slowly lowered simultaneously, until the trace on the oscilloscope steps from LOW to HIGH. The actual operating voltage should be within the tolerances given in Table PT-I for the value of test current used.

To check the "MT" function at other angles, refer to the **TYSTEST** computer program provided in the **SOFTWARE** section of this manual.

**Switched-Zone Test**

The Switched-Zone test with specific settings for a particular application can be conducted by the same method as specified under **ACCEPTANCE TESTING**. To determine the required values for Tables AT-VI and AT-VII, refer to the **TYSTEST** computer program provided in the **SOFTWARE** section of this manual.

**MB Reach Test**

Use the connections shown in Figure AT-3 for the appropriate phase to be tested.

Set the current and voltage phase angles per Table PT-V.

TABLE PT-V

Phase A $I_{OP}$ Lead by	$360 - (\Theta_B + 180)^\circ$
Phase B $I_{OP}$ Lag by	$120 - [360 - (\Theta_B + 180)]^\circ$
Phase C $I_{OP}$ Lead by	$[360 - (\Theta_B + 180)] + 120^\circ$
$V_A$	$0^\circ$
$V_B$	$-120^\circ$
$V_C$	$+120^\circ$

Where  $\Theta_B$ , the phase angle of  $I_{OP}$ , is determined by the following expression:

$Z_B =$

$$\left(\frac{r}{1-K_V}\right) \times \left[ \left(1 + \frac{0.1 \times K_V}{3}\right) \angle \phi Z_1 + \left(\frac{K}{3}\right) \angle \phi Z_0 \right]$$

$Z_B = |Z_B| \angle \Theta_B$

WHERE:

- $\phi Z_1$  is the positive-sequence impedance characteristic angle setting, found on the front panel of the ISM11(-) module, Figure MO-9.
- $\phi Z_0$  is the zero-sequence

impedance characteristic angle setting, found on the front panel of the ISM11(-) module.

"r" is the nameplate reach setting located on the front panel of the ABM11(-) module, Figure MO-2.

K is the zero-sequence current compensation factor, found on the ABM11(-) module.

$K_V$  is the positive-sequence voltage compensation factor, found on the ABM11(-) module.

The nominal operating voltage for "MB", at the angle of maximum reach in the blocking direction ( $\Theta_B + 180^\circ$ ), is given in Equation 9.

$$V_{NOM} = I_{TEST} \times |Z_B| \tag{9}$$

WHERE:

$V_{NOM}$  is the phase-to-ground pickup voltage

$I_{TEST}$  is the test current

$Z_B$  is the reach in the blocking direction, as determined above

PT

Set voltage  $V_A$ ,  $V_B$  and  $V_C$  to 67 volts rms. Set the current to the value shown in Table PT-IV. Simultaneously reduce the three-phase voltage, and check that the appropriate pin on the card extender goes from LOW to HIGH. The actual operating voltage should be within the tolerances given in Table PT-I for the value of test current used.

**NOTE:** The test currents indicated in Table PT-IV should only be used as guidelines. The maximum amount of test current that can be applied to obtain a favorable test result is determined by several factors, e.g. "MB" reach setting, K setting,  $K_V$  setting, etc. Therefore, to make certain that the maximum allowable test current has not been exceeded, refer to the **TYSTEST** computer program furnished in the **SOFTWARE** section of this manual.



## PERIODIC TESTING

---

To check the "MB" function at other angles, refer to the TYSTEST computer program provided in the SOFTWARE section of this manual.

### MOB Test

The MOB function can be tested with specific settings for a particular application by the same method as specified under ACCEPTANCE TESTING. To determine the required values for Table AT-IX, refer to the TYSTEST computer program provided in the SOFTWARE section of this manual.

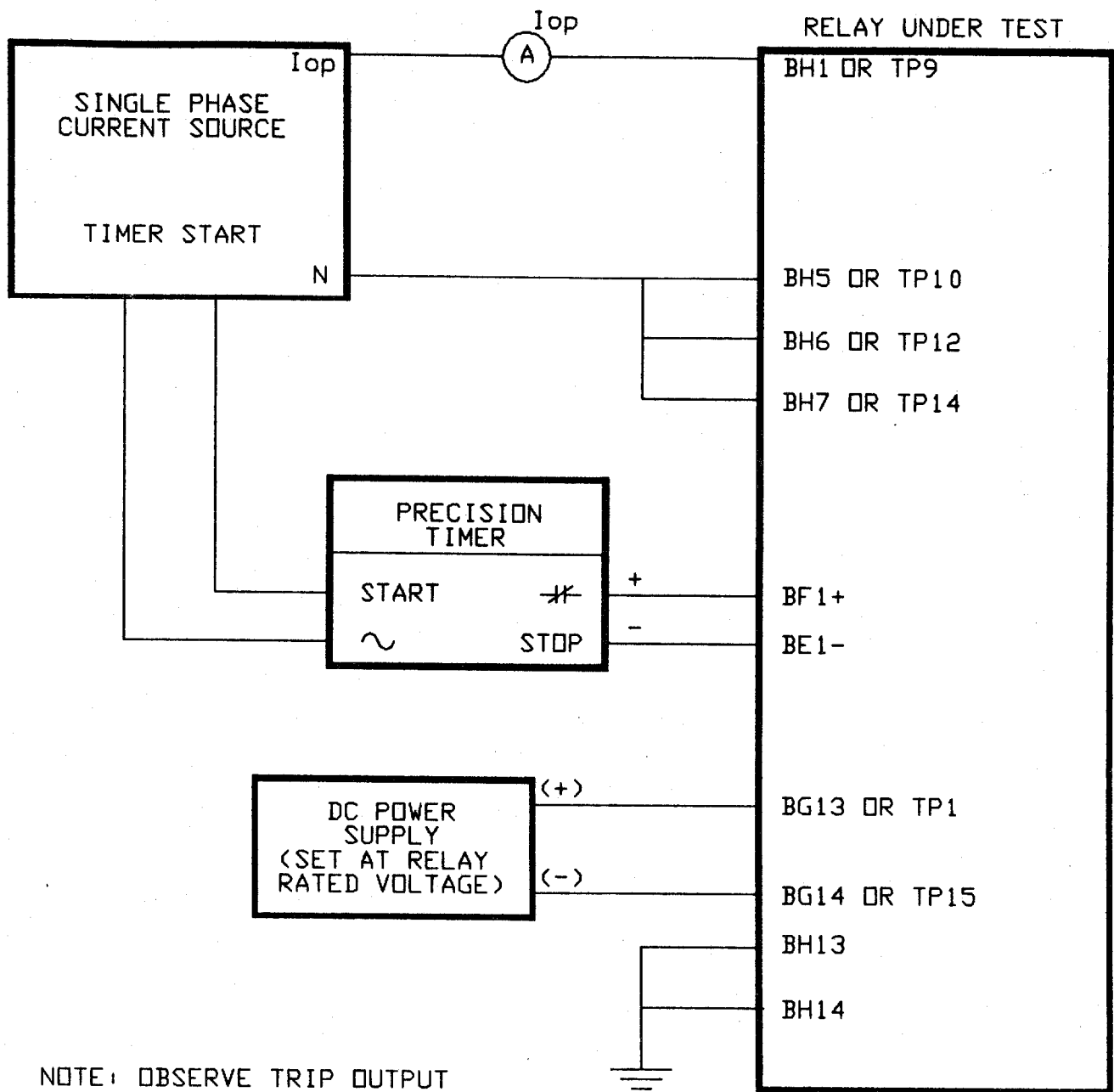

PT

NOTE: OBSERVE TRIP OUTPUT POLARITY FOR SCR TRIPPING MODELS.

\* Figure PT-1 (0286A2862 [1]) Connections for TOC Time Verification Test

\* Added since last issue



## SERVICING

### SPARES

There are two basic approaches that may be followed in servicing the TYS. One approach is field service, where an attempt is made to replace defective components at the relay location. Generally, this will take the most time and require the highest degree of skill and understanding. It can also be expected to result in the longest system-outage time.

The preferred approach is module replacement, where a determination is made as to which function has failed and that function is replaced with a spare module. The system can then be quickly returned to service. Considerable time is saved, and there is much less pressure to make a decision about what to do with the defective part. This approach typically yields the shortest down time. It is recommended that a complete set of spare modules be kept at the main maintenance center.

For those who wish to repair at the component level, drawings are available from the factory. When requesting drawings, the following information must be supplied to the factory:

1. The model number of the module. (this is found on the lower part of the front nameplate of each module, e.g. ADM112);
2. The assembly number of the module. (this is found on the component side of the printed-circuit board. It is an eight-digit number with a letter inserted between the fourth and fifth digit and suffixed with a group identification, e.g. 0215B5865 G001 or G1);
3. The revision number (this is also found on the printed-circuit board, e.g. REV.1).

### WITHOUT THE CONTINUOUS MONITOR MODULE

By inserting an extender card into the test slot, location "B", (see Figure MO-1 in the MODULES section) one can gain access to various points throughout the TYS. This feature is extremely useful when testing and servicing the TYS.

If the Continuous Monitor, which is an option that is also a useful device for testing and servicing the TYS, is not provided, a second extender card can be inserted into the slot reserved for it, location "D" (Figure MO-1 in the MODULES section). This gives access to additional points throughout the TYS.

The pin number on the extender card versus signal for the test points (TP-) that are shown in the Logic Diagram, Figure SD-2 (in the SCHEME DESCRIPTION section), is given in Table SE-I. The pin number on the extender card versus the monitor points (CM-), also shown in the Logic Diagram, is given in Table SE-II.

SE

### WITH THE CONTINUOUS MONITOR MODULE

When the TYS is equipped with the optional Continuous Monitor, many problems can be quickly located. When a failure occurs that causes one or more internal logic levels to shift, this will normally cause one of the many points monitored by the Continuous Monitor to go to an abnormal state. If the monitored point stays in this state for more than 5-10 seconds, the Continuous Monitor will give a Monitor Alarm contact closure. The front panel MON DATA indicator on the TAM 101 module, Figure CM-6, will also light.

**TABLE SE-I  
TEST SOCKET PIN ASSIGNMENTS**

PIN NUMBER	SIGNAL	PIN NUMBER	SIGNAL
1	REFERENCE	31	AND410 (TRIP BUS)
2	M1 AB	32	OR405 (TRIP PERM)
3	M1 BC	33	AND407 (CH TRIP)
4	M1 CA	34	OR204 (ZONE 1)
5	----	35	TL2 (ZONE 2)
6	----	36	TL3 (ZONE 3)
7	----	37	OR201 (LOCAL TR)
8	MT AB	38	OR304 (LINE PU)
9	MT BC	39	AND 50 (ALL MT'S)
10	MT CA	40	----
11	----	41	----
12	----	42	----
13	----	43	OR411 (PTFF)
14	NB	44	----
15	MB A	45	TL6 (OSB)
16	MB B	46	AND216 (TRIP SPV)
17	MB C	47	OR302 (LOCAL BLK)
18	NT	48	TL1 (TRIP INTGR)
19	IDT	49	OR210 (FD SPV)
20	ILOC	50	AND208 (CARR STR)
21	IPT	51	OR213 (CARR STOP)
22	IPB	52	----
23	IM	53	----
24	I1	54	----
25	FD	55	CC1 (RCVR#1)
26	NOT V1	56	CC2 (EXT TRIP)
27	MOB	57	CC3 (EXT BLOCK)
28	ILOC PICKUP	58	----
29	OR60 ANY MB	59	CC5 (LPU SUPV'N)
30	----	60	+12VDC

There are two different methods by which the operator can determine which point or points failed. He can place the front panel DATA SELECT switch in the MON DATA position and step through the display of abnormal points, using the STEP DISPLAY switch. When this method is used, the numbers of the abnormal points need to be recorded at this time.

The other alternative is to interrogate the Continuous Monitor through the serial data link. If monitor data is requested, the video terminal will display all the abnormal point numbers. The operator can leave these numbers on the screen to work from, or they can be

**\* TABLE SE-II  
CONTINUOUS MONITOR POINT  
NUMBER ASSIGNMENTS**

MONITOR POINT	SIGNAL	SOURCE	INPUT PIN
1	NOT USED		
2	NOT USED		
3	NOT USED		
4	NOT USED		
5	MT AB	UTM112	14
6	MT BC	UTM112	44
7	MT CA	UTM112	15
8	M1 AB	UTM112	45
9	M1 BC	UTM112	37
10	M1 CA	UTM112	7
11	FDP	ULM233	36
12	LPU	ULM233	6
13	TL2	ULM233	35
14	TL3	ULM233	5
15	NOT USED		
16	NOT USED		
17	RCVR	ULM222	39
18	OR406	ULM233	9
19	AND407	ULM222	38
20	AND417	ULM222	8
21	OR204	ULM222	10
22	PTFF	ULM233	40
23	AND301 (NB)	ULM256	11
24	MB	UTM112	41
25	OR201	ULM222	24
26	OR407	ULM233	54
27	TL1	ULM222	25
28	AND216	ULM233	55
29	IDT	CTM12(-)	26
30	TOC	CTM12(-)	56
31	OR302	ULM256	27
32	----	-----	
33	AND501	ULM233	49
34	AND302	ULM233	19
35	OR401(Timer III)	ULM233	48
36	OR403	ULM222	18
37	OR10	ULM222	47
38	----	-----	
39	CC2	ULM222	46
40	NT	ADM112	16
41	(I0-KI1)	CTM12(-)	51
42	AND500	ULM222	21
43	OR213	ULM256	50
44	AND50	ULM222	20
45	AND208	ULM256	22
46	AND206 (RI)	ULM233	52
47	FD	ABM11(-)	23
48	TRIP BUS	ULM233	53

\* Revised since last issue

copied from the screen and entered in the log.

These abnormal point numbers are the signal input numbers to the Continuous Monitor. Refer to Table SE-II to find the mnemonic of the TYS signal connected to this input. Table SE-II also gives the module where the signal originates. Refer to the system Logic Diagram, Figure SD-2 in the SCHEME DESCRIPTION section, and locate the abnormal signal levels on this diagram. Locate the earliest abnormal points, that is, the points closest to the AC inputs to the TYS. The problem is normally ahead of this point. Abnormal points that follow the first abnormal point in a signal path probably do not indicate a fault at these points. If there is an earlier, monitored, logic level in the same signal path that is normal, then the problem will usually be between the normal and the abnormal points.

If there is no earlier logic point, then the AC inputs to the TYS that drive the abnormal logic point should be checked. Refer to the Measuring Functions Block Diagram, Figure SE-1 in this section, and locate the abnormal signal levels on this diagram.

The techniques just described locate failures that resulted in monitor alarms from the continuous monitor. If a failure is suspected of causing a false trip, then the trip data in the Continuous Monitor must be analyzed. Obtain the trip data point numbers using the front panel controls: DATA SELECT, TRIP DATA, STEP DISPLAY and LCD display, or by using the serial data link. See if point 48 went to its abnormal state, HIGH. If not, the trip did not originate in the trip bus connected to the TYS. If point 48 went abnormal, see if point 47 went HIGH (abnormal state). If so, then there was a system disturbance and the trip probably was not a false trip. Check the event recorder, if used, and see if a trip condition did exist.

If there was no fault detector signal (point 47 did not go HIGH) then there was an error in the TYS. As in the case of a monitor fault, look for the earliest abnormal point in the signal path. Replace

the module where this abnormal point is located. If the fault can not be localized as occurring between a normal and an abnormal monitored point, then it may be necessary to replace all modules between the abnormal point and the AC inputs that supply signals to the abnormal point.

## POWER SUPPLY MODULE

Check the following items if the LED found on the front panel of the PSM21(-) module (Figure MO-13) fails to light when the Power Supply is turned on:

Correct DC supply is applied to the TYS.

Connection plugs, located on the left side of the MGM module (see Figure MO-1), are properly inserted into the test receptacle.

Condition of the fuse located on the PSM21(-) module, (Figure MO-13).

Correct voltages from the Power Supply Module.

The voltages should be within  $\pm 5\%$  of nominal. Check each of the following voltages with respect to pins 1, 30, 31 or 60:

Pins 4 or 34	+24 VDC
Pins 2 or 32	+12 VDC
Pins 29 or 59	-12 VDC

The following voltage is checked with respect to pins 25 or 55, and it should also be within  $\pm 5\%$  of nominal:

Pins 21 or 51	+24 VDC.
---------------	----------

SE

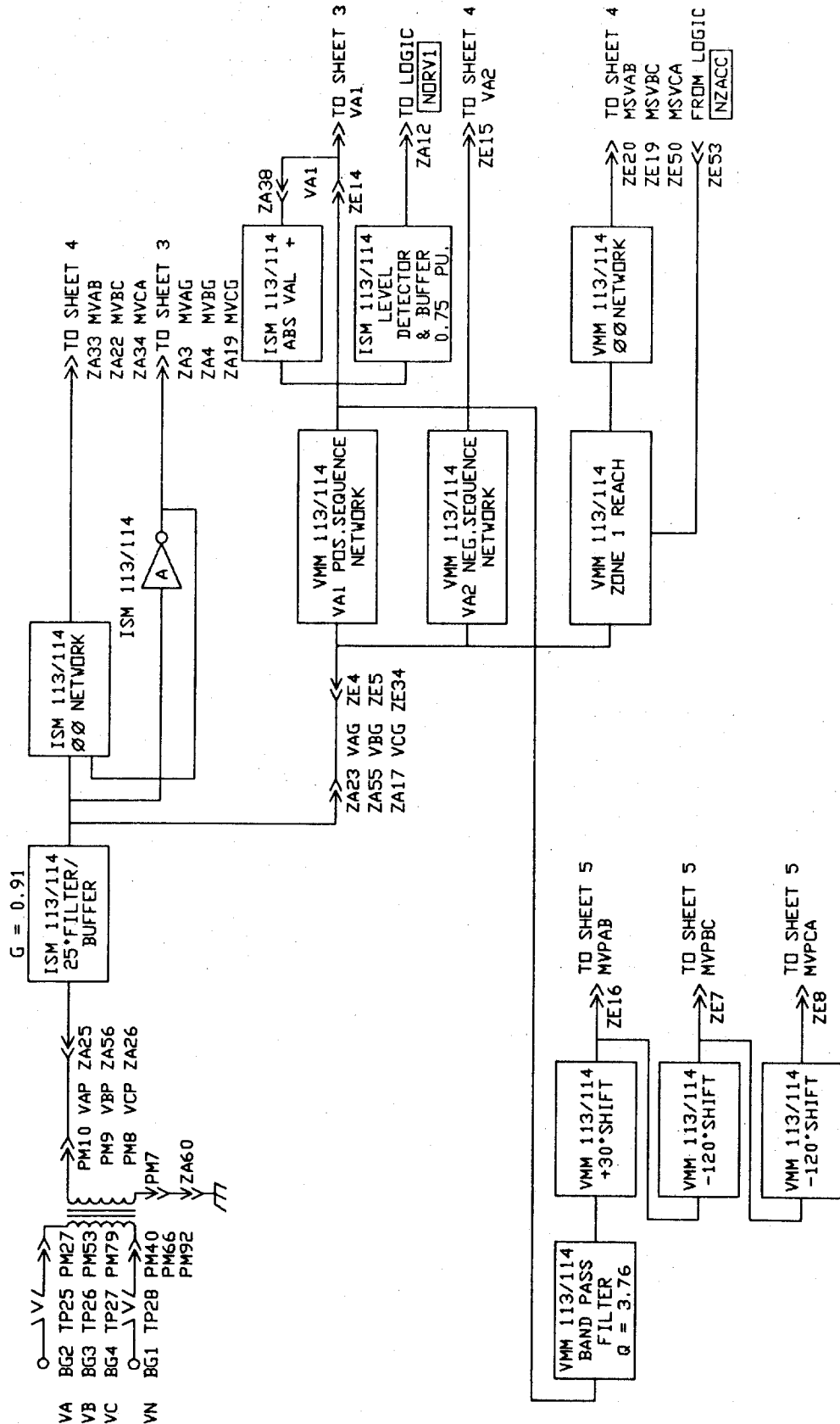

Figure SE-1 (0184B5676 Sh.1 [1]) Measuring Functions Block Diagram

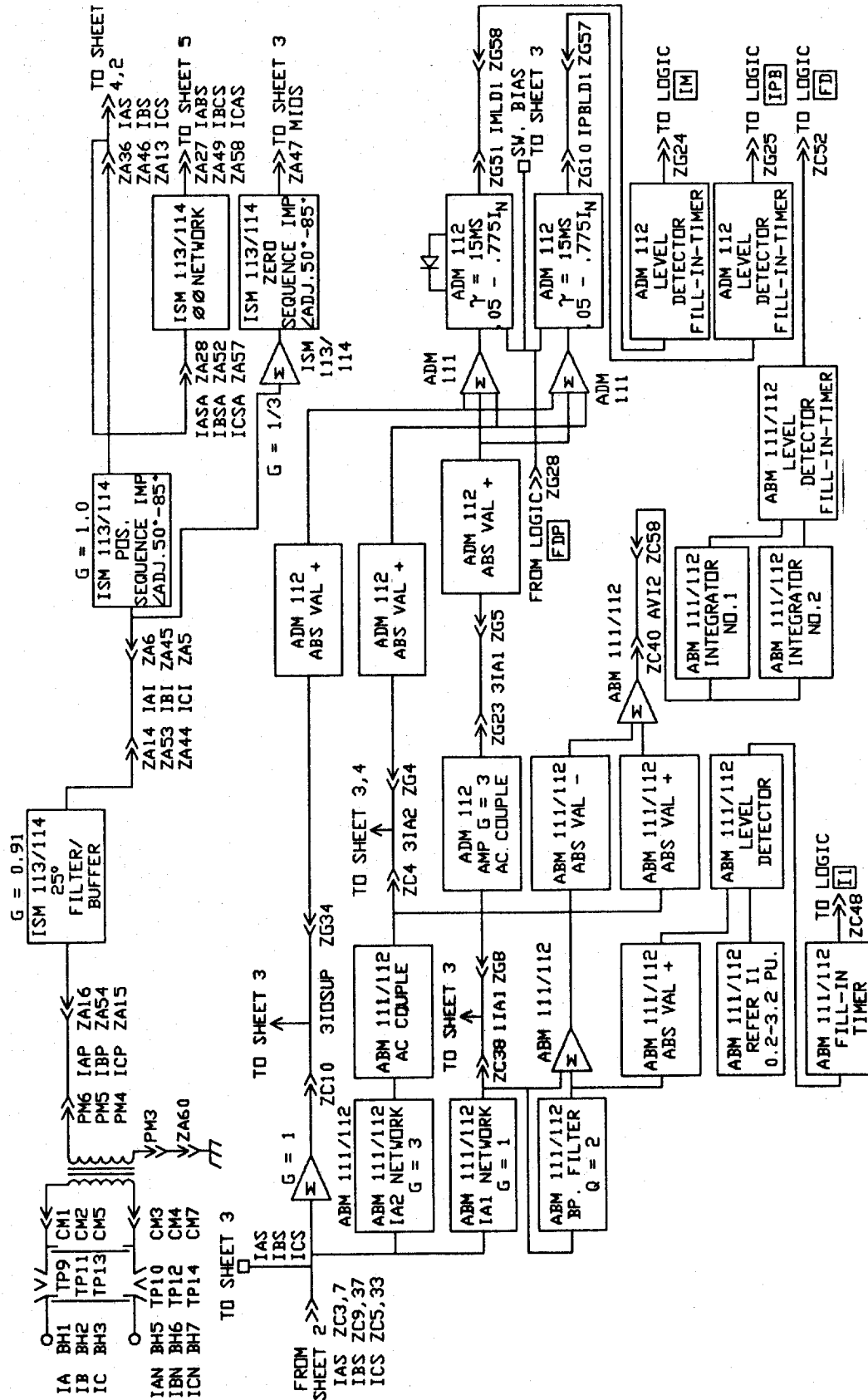

Figure SE-1 (0184B5676 Sh.2 [1]) Measuring Functions Block Diagram







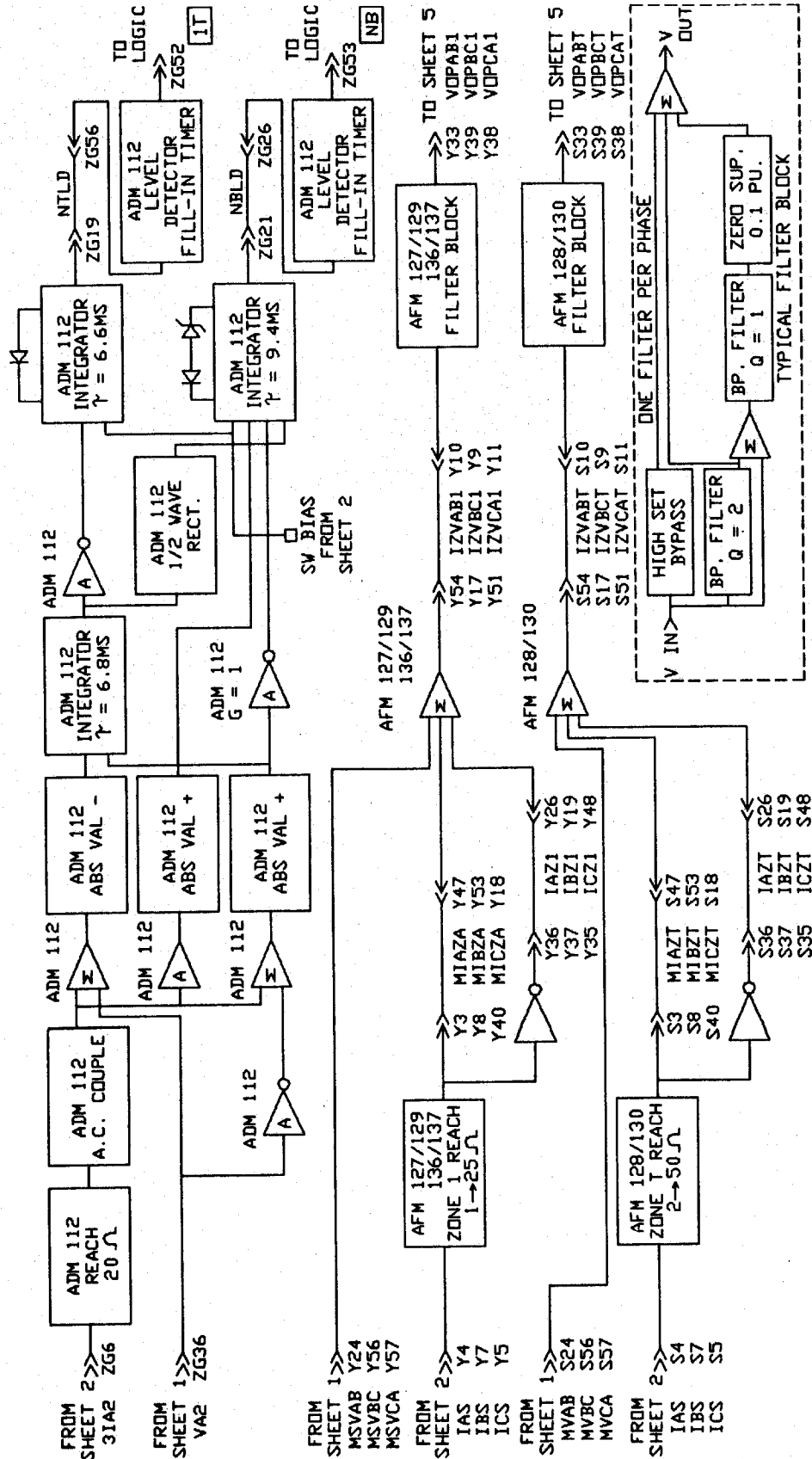

Figure SE-1 (0184B5676 Sh.4 [1]) Measuring Functions Block Diagram



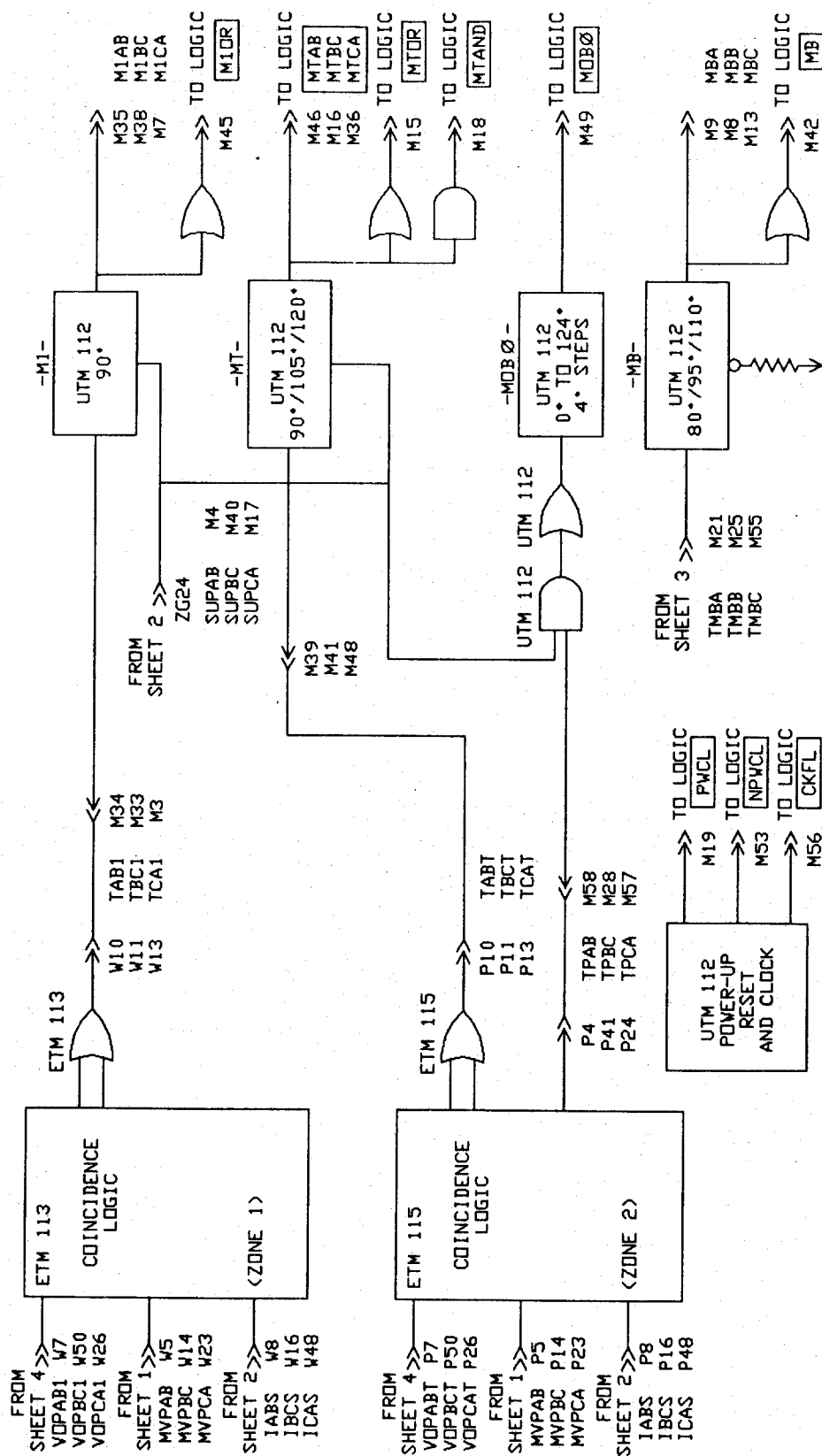
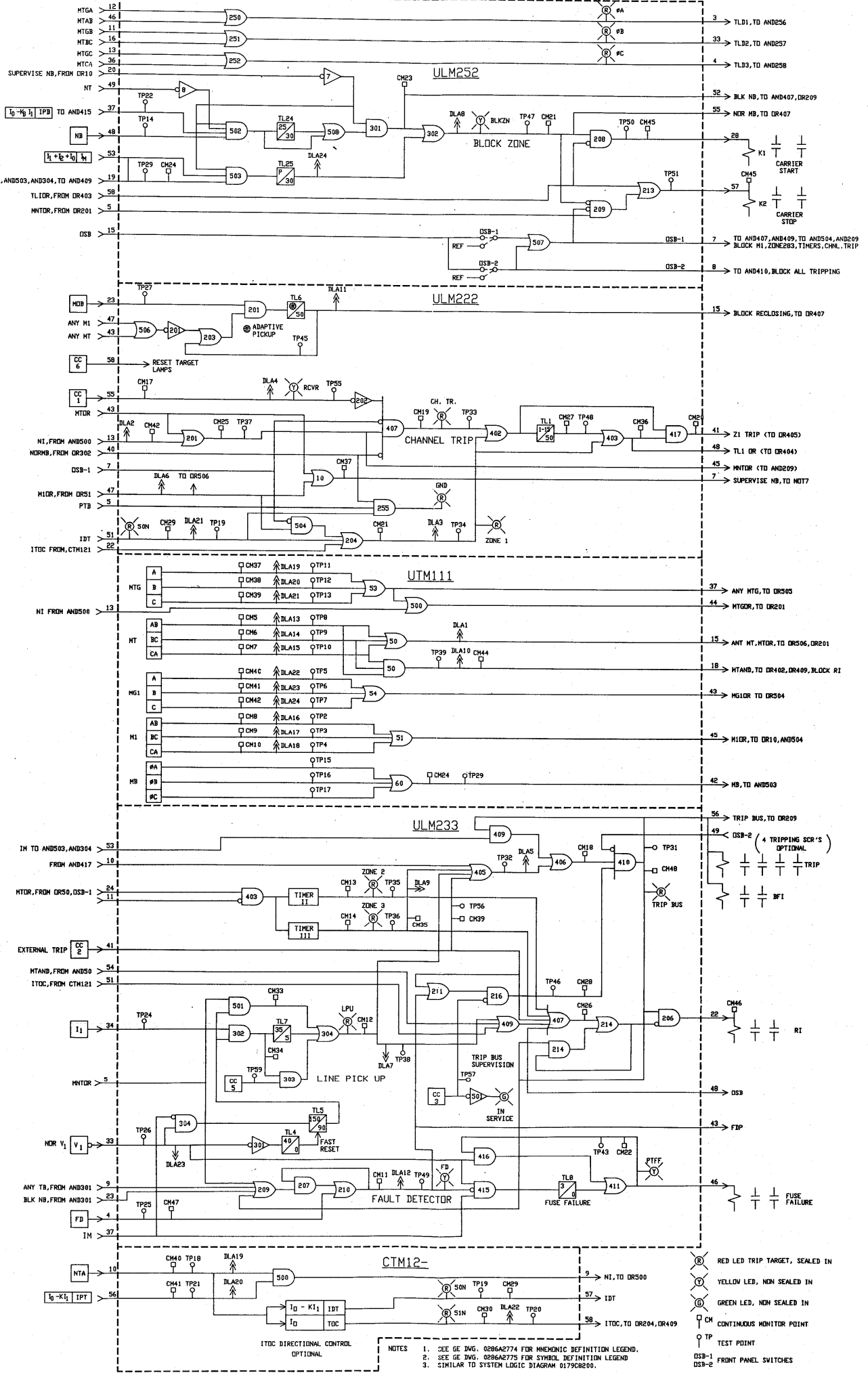

Figure SE-1 (0184B5676 Sh.5 [1]) Measuring Functions Block Diagram

\* Revised since last issue

\* Figure SE-2 (0153D7643 [3]) Service Logic



- NOTES
1. SEE GE DWG. 0286A2774 FOR MNEMONIC DEFINITION LEGEND.
  2. SEE GE DWG. 0286A2775 FOR SYMBOL DEFINITION LEGEND.
  3. SIMILAR TO SYSTEM LOGIC DIAGRAM D179C8200.

- RED LED TRIP TARGET, SEALED IN
- YELLOW LED, NON SEALED IN
- GREEN LED, NON SEALED IN
- CM CONTINUOUS MONITOR POINT
- TP TEST POINT
- DSB-1 FRONT PANEL SWITCHES
- DSB-2 FRONT PANEL SWITCHES

## SPECIFICATIONS

### RATINGS

Rated Frequency	50 or 60 hertz
Rated Voltage	100 to 120 volts AC
Rated Current	$I_N = 1$ or 5 amperes
DC Control Voltage	48 VDC, Operating Range 34 - 60 VDC 110/125, Operating Range 88 - 150 VDC 220/250, Operating Range 176 - 300 VDC
Maximum Permissible Currents	
Continuous	$2 \times I_N$
Three Seconds	$50 \times I_N$
One Second	$100 \times I_N$
Maximum Permissible AC Voltage	
Continuous	2.0 x rated
One Minute (one per hour)	3.5 x rated
Ambient Temperature Range	
Storage	$-30^{\circ}\text{C}$ to $+75^{\circ}\text{C}$
Operation	$-20^{\circ}\text{C}$ to $+65^{\circ}\text{C}$
Humidity	95% without condensing
Insulation Test Voltage	2 kV 50/60 Hz, one (1) minute
Impulse Voltage Withstand	5 kV peak, 1.2/50 milliseconds, 0.5 joule
Interference Test Withstand	1 MHz, 2.5 kV peak decay time of 3 to 6 cycles to 1/2 value

### BURDENS

Current Circuits	0.03 ohm $\angle 5^{\circ}$ , $I_N = 5$ amps 0.14 ohm $\angle 30^{\circ}$ , $I_N = 1$ amp				
Voltage Circuits	0.2 VA $\angle 49^{\circ}$ , 60 hertz 0.24 VA $\angle 48^{\circ}$ , 50 hertz				
DC Battery (for contact converters)	1.4 milliamperes each				
DC Battery (for Power Supply and Telephone Relays)	<table border="0" style="margin-left: auto; margin-right: auto;"> <tr> <td style="text-align: center; border-bottom: 1px solid black;">Normal</td> <td style="text-align: center; border-bottom: 1px solid black;">Tripped</td> </tr> <tr> <td style="text-align: center;">15 watts</td> <td style="text-align: center;">40 watts</td> </tr> </table>	Normal	Tripped	15 watts	40 watts
Normal	Tripped				
15 watts	40 watts				
ALL VOLTAGE RATINGS					



SPECIFICATIONS

---

CONTACT DATA

Trip Outputs	Continuous rating = 3 amperes Make and carry for tripping duty: (per ANSI C37.90) = 30 amps Break 180 VA resistive at 125/250 VDC Break 60 VA inductive at 125/250 VDC
Thyristor Outputs	Same as trip contacts except no interrupting rating
Auxiliary Outputs (including Alarms)	Continuous rating = 3 amperes Make and carry for 30 seconds = 5 amperes Break 25 watts inductive at 125/250 VDC Make and Carry continuously 50 watts Maximum of 250 volts or 0.5 ampere
DLA and Channel Control Contacts	10 watts 250 VDC maximum, 0.5 amp maximum

REACH-SETTING RANGES

TABLE SP-I

FUNCTION	MEASURING UNIT	RANGE IN OHMS		RESOLUTION	
		$I_N=5$	$I_N=1$	$I_N=5$	$I_N=1$
Zone 1†	M1	0.1 to 2.5	0.5 to 12.5	0.01	0.05
Zone 1††	M1	1.0 to 25	5.0 to 125	0.1	0.5
Zone 2	MT	2.0 to 50	10 to 250	0.2	1.0
Blocking	MB	2.0 to 50	10 to 250	0.2	1.0

† short-reach models †† long-reach models

REACH EXTENSION FACTOR

TABLE SP-II

FUNCTION	MEASURING UNIT	RANGE	RESOLUTION
Zone 1	M1	$(1 - 10) \times \text{Zone 1}$	0.05

**OVERCURRENT-FUNCTION-SETTING RANGES**

**TABLE SP-III**

FUNCTION	OVERCURRENT-FUNCTION SETTING			
	RANGE IN AMPS		RESOLUTION	
	$I_N=5$	$I_N=1$	$I_N=5$	$I_N=1$
Pilot Tripping (IPT)	0.5 to 5.0	0.1 to 1.0	0.25	0.05
Pilot Blocking (IPB)	0.25 to 3.78	0.05 to 0.75	0.125	0.025
Time Overcurrent (ITOC)	0.25 to 3.0	0.05 to 0.6	0.25	0.05
Istantaneous Overcurrent (IDT)	2.0 to 20	0.4 to 4.0	0.5	0.1

**TOC TIME DIAL**

**TABLE SP-IV**

FUNCTION	TOC TIME-DIAL SETTING IN MULTIPLE OF PICKUP CURRENT	
	RANGE	RESOLUTION
TOC Time Dial (TD)	0.5 to 10	0.5

**SUPERVISION-FUNCTION-SETTING RANGES**

**TABLE SP-V**

FUNCTION		RANGE IN AMPS		RESOLUTION	
		$I_N=5$	$I_N=1$	$I_N=5$	$I_N=1$
Overcurrent Supervision	(IM)	0.25 to 3.78	0.05 to 0.75	0.125	0.025
MT Overcurrent Supervision	( $I_{\phi\phi}$ )	0.5 to 5.0	0.1 to 1.0	0.5	0.1
Line Pickup	( $I_1$ )	1.05 to 16	0.2 to 3.2	1.0	0.2

SP

**COMPENSATION-FACTOR-SETTING RANGES**

**TABLE SP-IV**

FUNCTION		RANGE	RESOLUTION
Positive-Sequence Voltage	( $K_V$ )	0.0 to 0.45	0.15
Zero-Sequence Current	(K)	1.0 to 7.0	0.1

**SPECIFICATIONS**

---

**REPLICA-IMPEDANCE-ANGLE SETTINGS**

The replica impedance angle is adjustable from 50° to 85° in 5° steps with a switch mounted on the front panel of the ISM11(-) module, Figure MO-8.

**ADJUSTABLE LOGIC TIMERS**

**TABLE SP-VII**

TIMER	RANGE	RESOLUTION	DESCRIPTION
TL1	0 - 15.75 ms	0.25 ms	Trip Integrator
TL2†	0 - 3.1 sec	0.1 sec	Zone Two
TL3†	0 - 3.1 sec	0.1 sec	Zone Three

† Can be defeated by setting the front-panel-mounted switches to the 'OUT' position

**ACCURACY**

Distance Measuring Units

Reach: ± 5% of setting at angle of maximum reach and rated current

Angle of Maximum Reach: ± 3° of setting

Zone Timers

± 3% of setting

**CURRENT SENSITIVITY**

The current sensitivity for the phase distance units is determined from:

$$I_{\theta\theta} Z_{R1} = \frac{(0.905)(RM)}{(1 - X)}$$

WHERE:  $I_{\theta\theta}$  is the phase - phase current at relay (i.e.,  $I_A - I_B$ )  
 $Z_{R1}$  is the positive-sequence relay reach  
 RM is a design constant (see Table SP-VIII below)  
 X is the actual reach / nominal reach

**TABLE SP-VIII**

REACH RANGES	RM
(0.1 - 2.5) (5/ $I_N$ )	0.25
(1 - 25) (5/ $I_N$ )	1
(2 - 50) (5/ $I_N$ )	1



**EXAMPLE:**

For the phase pair A - B unit and:

$$Z_{R1} = 3$$

$$RM = 1$$

$$X = 0.95; (1-X) = 0.05 \text{ (5\% pull back)}$$

$$I_A - I_B = \frac{(.905)}{(.05)(3)} = 6.03$$

For a phase - phase fault:

$$I_A - I_B = 2I_A = 6.03$$

$$I_A = 3.015$$

For a three-phase fault:

$$I_A - I_B = \sqrt{3} I_A = 6.03$$

$$I_A = 3.48$$

**DIMENSIONS**

Height	14 inches (356 millimeters) 8 rack units
Width	19.1 inches (484 millimeters) Standard 19 inch rack
Depth	16 inches (406 millimeters)

**WEIGHT**

Standard rack-mounted unit weighs approximately 45 pounds  
(20 kilograms)



# CONTINUOUS MONITOR MODULE

## BASIC OPERATION

The continuous monitor function works on the principle of recognizing a change in state of one or more of up to 40 monitored points (reference Table SE-II in the SERVICING section) as an abnormal relay system condition if this change in state occurs when the power system is in a quiescent state. This means that the process must know the state of the power system at all times (i.e., quiescent or fault). A fault detector (FD) is used to determine the state of the power system. This same fault detector may also be used to supervise a trip output from the relay system's scheme logic, even if the optional Continuous Monitor module is not included. The fault detector responds to negative- and zero-sequence current levels

as well as the change in the positive-sequence current.

A microprocessor, software stored in an EPROM, and other required support chips are the hardware/software that comprise the Continuous Monitor module. The module operation can be described functionally with the aid of Figure CM-1. If one or more of the monitored points changes state (either logic level 0 to 1 or logic level 1 to 0), the fault detector has not operated, and this condition persists for a minimum of 5 seconds, then the Continuous Monitor module issues an alarm output to indicate that an abnormal condition - a relay system failure - has occurred. Based on the actual software and hardware implementation, the "A" time delay in Figure CM-1 is not a fixed value, but rather a statistically variable 5 seconds minimum and 10 seconds maximum. An

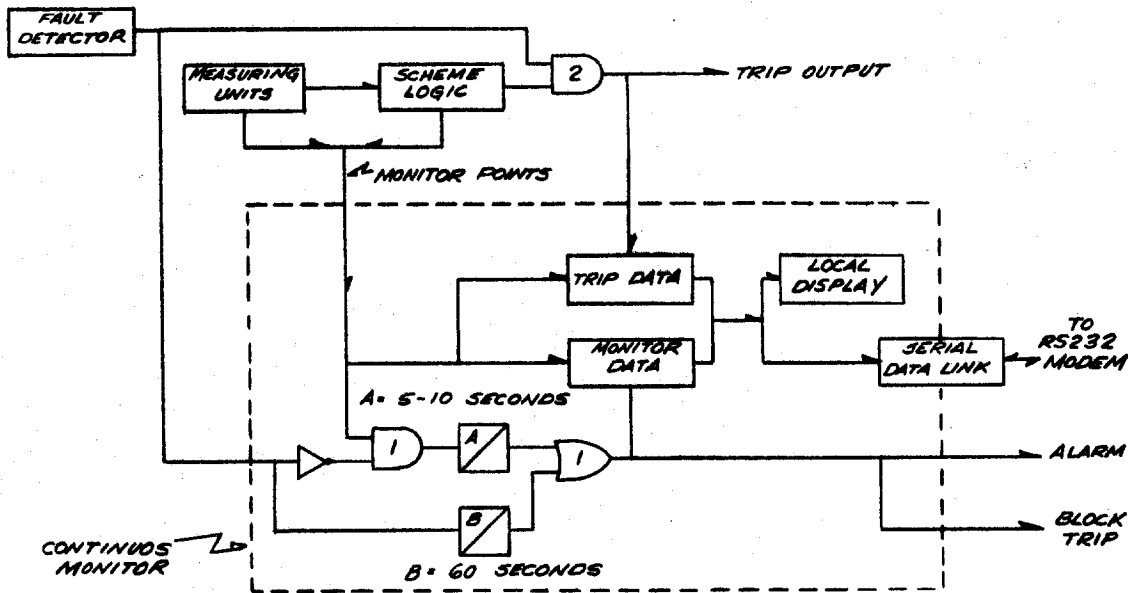

Figure CM-1 (0285A9897) Simplified Functional Diagram Depicting Continuous Monitor Operation

alarm output is also produced if a fault detector output persists for 60 seconds. This would be an indication that the fault detector itself had failed.

No monitor data will be taken after a bad fault detector is sensed. To alert the user, the program displays "FD" on the front panel LED numeric display after it senses a bad fault detector. It is still possible to use the STEP DISP. pushbutton to step through the trip and monitor data. If this is done, the "FD" does not reappear on the display. For this reason, the LED labeled MON. DATA on the front panel is made to blink continuously after a fault-detector failure. This alerts the operator to the fact the unit is not operating normally.

Once OR1 in Figure CM-1 produces an output, indicating a relay system failure, the microprocessor program stores bit patterns in non-volatile memory that identify which monitored point(s) changed state. These "faulty" monitored points are not stored in chronological order, nor time-tagged, but are simply accumulated in memory. Repeated operation and reset of a particular monitored point does not result in this point being stored more than once. This accumulation of "faulty" monitored points continues until the memory is cleared. Since non-volatile memory is used, the data is not lost if the DC power supply is turned off or the DC is removed externally. To clear the memory, a CLEAR command must be given by either (1) the operator pushing a button on the front panel of the module or (2) a remote terminal communicating with the module via a serial data link. When the first relay system failure is detected, the Continuous Monitor module closes an alarm contact that remains closed until the memory is cleared.

### ADDITIONAL FUNCTION

The primary function of the Continuous Monitor module is to detect and to alarm for a relay-system failure. The other function is to store in non-volatile memory those monitored points that changed state during a relay-system trip output. Following a trip output, the

Continuous Monitor module scans the monitored points for 10 milliseconds. Any points that change state within this 10 millisecond interval are accumulated in memory as trip data. This can be useful in analyzing relay system response to particular faults. This function and its memory are separate and distinct from the primary function of detecting relay-system failures. The Continuous Monitor module can have both "trip data" and "monitor data" in memory at the same time.

Data for five (5) trip events will be stored sequentially. If a sixth trip event occurs prior to the memory being cleared, then the data for the first trip event will be overwritten by the data for the sixth trip event. Thus the data for the five most recent trip events will be retained.

The front panel display shows "FB" on the LED numeric display when the trip input to the Continuous Monitor is high. This was done to make the unit easier to test. Without this feature, it is difficult to avoid the appearance of a Continuous Monitor failure when the trip input is accidentally held high. This makes it difficult to diagnose the condition.

### ACCESS OF STORED DATA

Figure CM-2 shows the front panel of the Continuous Monitor module with its LEDs, two-digit LED numeric display, toggle switch and pushbuttons. The stored data, either monitor or trip, can be accessed locally at the front panel of the module, or it can be accessed from a remote terminal via an optional serial data link.

#### Local Access

For local access, the two LEDs on the front panel of the module indicate that monitor data and/or trip data are stored in memory. A DATA SELECT toggle switch is used to select which data are to be accessed. The step display (STEP DISP.) pushbutton is then pushed repeatedly to cause the stored points to be displayed via the two-digit point number (POINT NO.) LED numeric display.

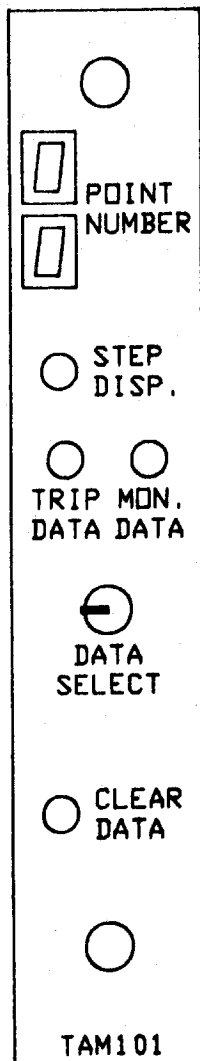

Figure CM-2 (0285A9898) Continuous Monitor Module Front Panel

After the DATA SELECT switch is set to the monitor data (MON DATA) position, the LED numeric display should show 0/0 (i.e., the upper and lower display digits are both zero) to indicate the beginning of the monitor data. If 0/0 is not displayed, the STEP DISP. button should be pushed to bring the display to 0/0. The next push of the STEP DISP. button will cause the first stored monitor point to be displayed and this process is continued until 0/0 reappears on the LED numeric display to signal the end of the monitor data.

After the DATA SELECT switch is set to the TRIP DATA position, a 0/0 on the LED numeric display indicates the beginning of the trip data. Once again, successive operations of the STEP DISP. pushbutton cause all the trip data to be displayed between the initial 0/0 and the subsequent 0/0. However, additional codes, E/1, E/2 through E/5 are displayed to differentiate between the trip events. E/1 refers to the last trip event, E/2 to the next-to-last trip event, and E/5 to the first trip event, assuming five trip events are stored in memory. When starting from 0/0, the first push of the STEP DISP. button will cause E/1 to appear on the LED numeric display. Successive operations of the STEP DISP. button will cause all trip data points associated with the last trip event to be displayed, followed by E/2 to indicate the beginning of the trip data points associated with the next-to-last trip event. This continues until 0/0 is displayed to indicate the end of the trip data.

### Remote Access

For remote access, a serial data link must be supplied. The Continuous Monitor module includes the necessary software to operate with a serial data link and the chassis backplane wiring connects the input/output ports to a 25-pin connector on the rear of the chassis. This connector resembles an RS-232 connector, but it does not provide an RS-232 interface. To provide serial data transmission, a small, optional, fiber-optic transmitter/receiver module (FOM101) can be supplied, which consists of standard Hewlett Packard devices using SMA connectors and packaged by GE into a connector housing. This device is simply plugged into the 25-pin connector on the rear of the chassis. One means of completing the serial data link is to connect one end of a fiber-optic cable to the small fiber-optic transmitter/receiver module on the rear of the relay chassis and the other end to a commercially available fiber-optic-to-RS-232 converter. The RS-232 side of the converter can then be connected to a modem to provide remote access via telephone lines, as shown in Figure CM-3.

CM

## CONTINUOUS MONITOR MODULE

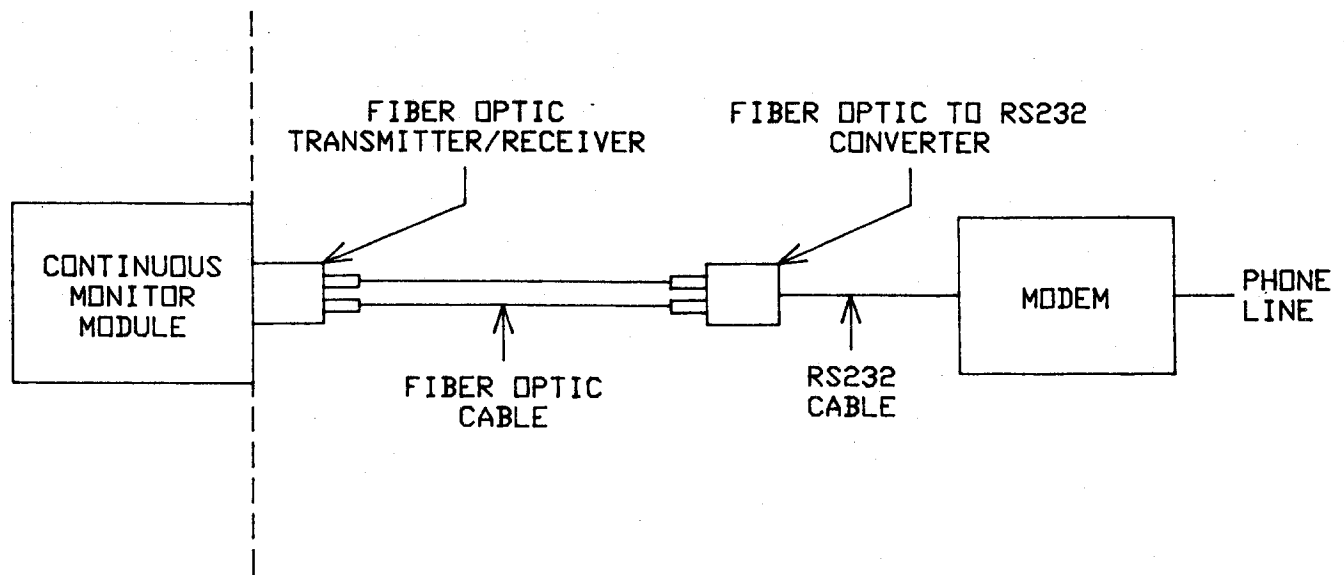

Figure CM-3 (0285A9899-2) Serial Data Link Connection

Either a "dumb" or a "smart" terminal may be used at the remote site, since no terminal software is required.

The serial data link option provides the user with the capability of remotely interrogating the Continuous Monitor module to read the data in memory and to clear the memory. Clearing the memory also clears the alarm contact. In the examples below, the full-duplex system as shown in Figure CM-3 is assumed, and the entries by the operator at the terminal are shown in parentheses. Carriage returns are not indicated, but every entry must be followed by a carriage return. Entries must be exactly as shown; extra spaces or added punctuation may cause the message to be ignored.

The first step in obtaining data remotely is to address the particular Continuous Monitor module by its identifying number (up to 16 unit-identification numbers can be assigned via a switch setting on the module). This module or unit-number designation allows several modules at one substation to be addressed via one serial data link. Assume that unit 2 is to be addressed. Enter the following at the keyboard:

(\*\*\*2)

The Continuous Monitor module will respond with one of the following messages:

***2 N	No data in memory
***2 M	Monitor data only in memory
***2 T	Trip data only in memory
***2 M T	Monitor and trip data in memory

Assume that "\*\*\*2 M T" is received, indicating the presence of both monitor and trip data.

To access the monitor data, enter the following at the keyboard:

(MON)

Assume the response is:

\*\*\*2 MON  
03 09 31

In this case, points 3, 9 and 31 are stored in memory.

To access the trip data, enter the following at the keyboard:

(TRIP)

Assume the response is:

```
***2 TRIP
06 20 21 22 25 37

06 20 21 22 25 37
```

The first line of data is for the most recent trip, while the last line is for the earliest trip in memory. In this example data are shown for two trip events, but up to 5 events could be present.

If a different Continuous Monitor module served by the same link is to be accessed at this time, it will be necessary to deselect the present module by issuing a QUIT command, and then to address the next module. To quit a module, enter the following at the keyboard:

(QUIT)

The QUIT command does not erase the memory of the currently addressed module. It does deselect and return to normal mode any unit receiving the command, whether selected or not.

### Clearing the Stored Data

The data can be cleared from memory either locally, via the module's front panel, or remotely, via the serial data link. Local clearing is accomplished by pushing the CLEAR DATA button located on the front of the module. The LED numeric display will show C/C until clearing is complete. Remote clearing of the selected unit is accomplished via the serial data link by entering the following command at the keyboard:

(CLEAR)

The CLEAR command, whether issued locally or remotely, clears both monitor and trip data from memory, and it resets the two contacts associated with the monitor alarm. When issued remotely, the CLEAR command also deselects the present module. If there is only one Continuous Monitor on a communications link, then either QUIT or CLEAR can be

used as the final command after interrogation.

If there are multiple Continuous Monitor modules, then QUIT should be used, since it will return all the units on the communication line to the normal state. QUIT will not clear the memory, whereas CLEAR will. If the memory is to be cleared in such cases, CLEAR should be sent to each module, then one QUIT command to return all to the normal state. The monitor alarm contacts close when monitor data is stored in memory, and stay closed until a CLEAR command is issued.

## MODES OF OPERATION

The Continuous Monitor module can be thought of as having three modes of operation: (1) monitor mode, (2) local-display mode, and (3) serial-data-link-access mode. Note that regardless of which mode the monitor is in, a relay-system trip will interrupt the program and trip data will be stored. The module is then returned to the monitor mode. Normally the module is in the monitor mode with no local-display-mode bits set. In this condition the module's front panel LED numeric display will show 0/0.

### Local-Display Mode

To enter the local-display mode the operator places the DATA SELECT switch at either the MON. DATA or the TRIP DATA position and pushes the STEP DISP. button. If there has been no trip since the last pass through the program, the program looks at the status (local-display mode) word to see if a display bit is set. There are two local-display-mode bits. One indicates that monitor data is to be displayed on the front panel LED numeric display. The other bit signifies that trip data is to be displayed. Only one of the two bits can be on at one time, and the presence of either bit will prevent use of the serial data link. To exit the local-display mode and return to the monitor mode, the operator changes the position of the DATA SELECT switch and pushes the STEP

CM

DISP. button once so that the LED numeric display shows 0/0. Pushing the CLEAR button will also return the module to the monitor mode, but will erase the data. After a 5 minute delay, initiated when the local display mode is first entered, the module will automatically revert to the monitor mode. If an operator happens to leave the module in the local-display mode, this automatic reversion will prevent the loss of all but the first five minutes of data from being lost. While in the local-display mode, the module continues its monitoring, as in the monitor mode, except on those program passes when it sees the STEP DISP. button operated or when a trip has just occurred.

**Serial-Data-Link-Access Mode**

When in the serial-data-link-access mode the module does not continue the monitoring it performs in the monitor mode; however it will record trip data, then leave the serial-data-access mode. While the Continuous Monitor module is sending or receiving data, local access via the module's front panel is also denied.

Assuming that there is only one Continuous Monitor module that can be addressed by the remote terminal, the normal way to terminate this mode and return to the monitor mode is to issue a CLEAR or QUIT command. If neither command is received, after a 5 minute delay, initiated when the serial-data-link-access mode is first entered, the module will automatically revert to the monitor mode, preventing the loss of all but the first 5 minutes' data.

When addressing several Continuous Monitor modules via one serial data link, all the modules will go to the serial-data-link-access mode when a signal is received over the link. In this case, QUIT will not only deselect the presently addressed module but also act as a "site global" command, since all of the Continuous Monitor modules will return to the monitor mode. CLEAR will deselect the presently addressed module and clear its memory, but it will not cause all the modules to revert to the monitor mode. If the terminal operator forgets to issue a QUIT command, each module will automatically revert

to the monitor mode following expiration of its individual 5 minute delay.

**CONTINUOUS MONITOR ADJUSTMENTS**

The only adjustment on this board is the address-setting switch. The location of this switch and the bit values of the individual switches are shown in Figure CM-6. The setting is the sum of the switch values. The setting can range from 0 to 15. Values from 10 to 15 correspond to addresses from Capital A to Capital F. This address is used to select a particular Continuous Monitor using the serial data link.

The front panel controls are as follows:

<u>Panel Marking</u> Point Number	<u>Description</u>
Step Disp.	Two-digit LED to display abnormal point input number. Top digit is the most significant.
Trip Data	Pushbutton to step Point Number to next point (in numerical order).
Mon. Data	LED that indicates, when lit, that trip data has been stored.
Data Select	LED that indicates, when lit, that monitor data has been stored.
Clear Data	Two-position switch to select either trip or monitor data on Point Number display.
	Recessed pushbutton that clears all memory data when operated.

**CONTINUOUS MONITOR SERIAL LINK USE**

The continuous monitor serial data link has the following characteristics:

Baud rate	300
Data bits	7
Parity	odd
Stop bits	1



When shipped, the TYS relay system chassis containing the Continuous Monitor is always wired to operate with the serial data link. To provide serial data transmission, a small fiber-optic transmitter/receiver module can be installed on the 25-pin connector on the rear of the chassis. This connector resembles an RS-232 connector, but it is NOT RS-232 compatible. This fiber-optic transmitter/receiver module (FOM101) is made by GE and contains only the optical transmitter and receiver to couple to and from the fiber-optic cables. The optical transmitter and receiver are standard Hewlett Packard devices, HFBR1402 and HFBR2402, which use SMA connectors. The other end of the fiber-optic cables (HFBR-3000 or equivalent) can be coupled to any suitable optical devices. Under normal conditions (no transmission) the fiber-optic transmitter at the chassis is OFF. The receiver at the chassis expects a similar "OFF" signal.

The simplest means of using the fiber-optic link is to purchase commercially available fiber-optic-to-RS-232 converters and related communications equipment. Figures CM-4 and CM-5 show two communication schemes that have been implemented.

## CHECKSUM

There is a checksum routine that continually checks for EPROM memory errors. If it detects a failure, the front-panel display will reach "C5". The monitor alarm will operate and monitor bit 16 will be set. If this occurs, the Continuous Monitor module should be replaced.

CM

**CONTINUOUS MONITOR**

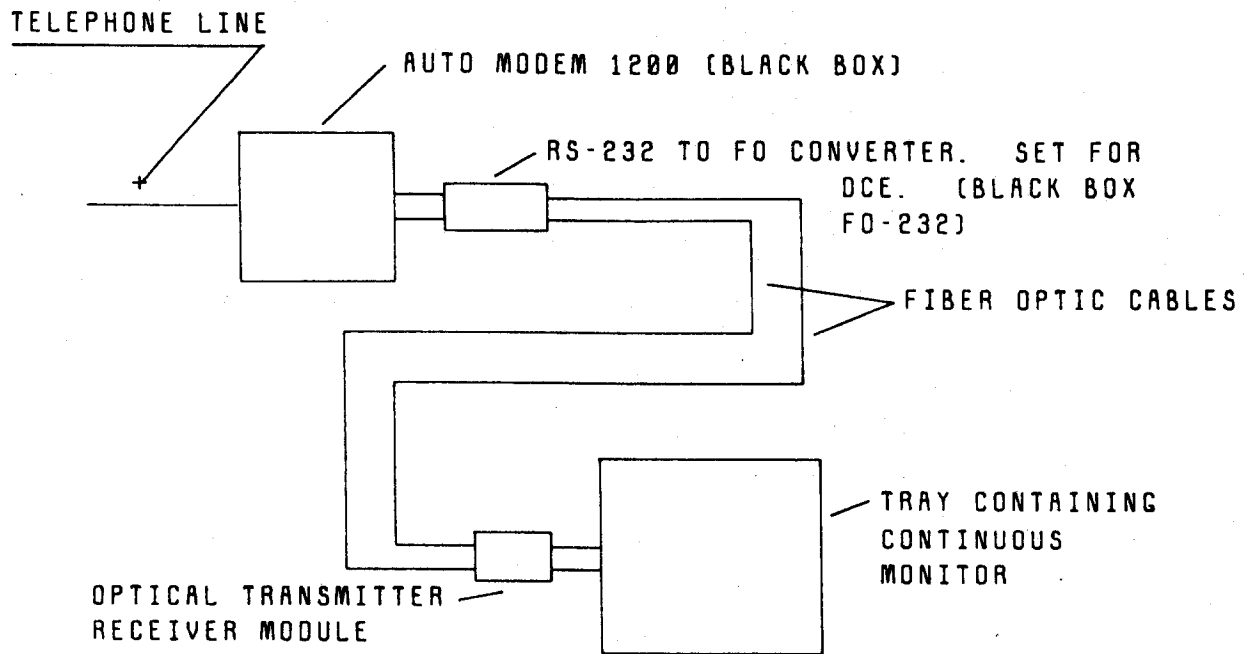

**Figure CM-4 (0285A9836-1) Continuous Monitor Phone Connection**

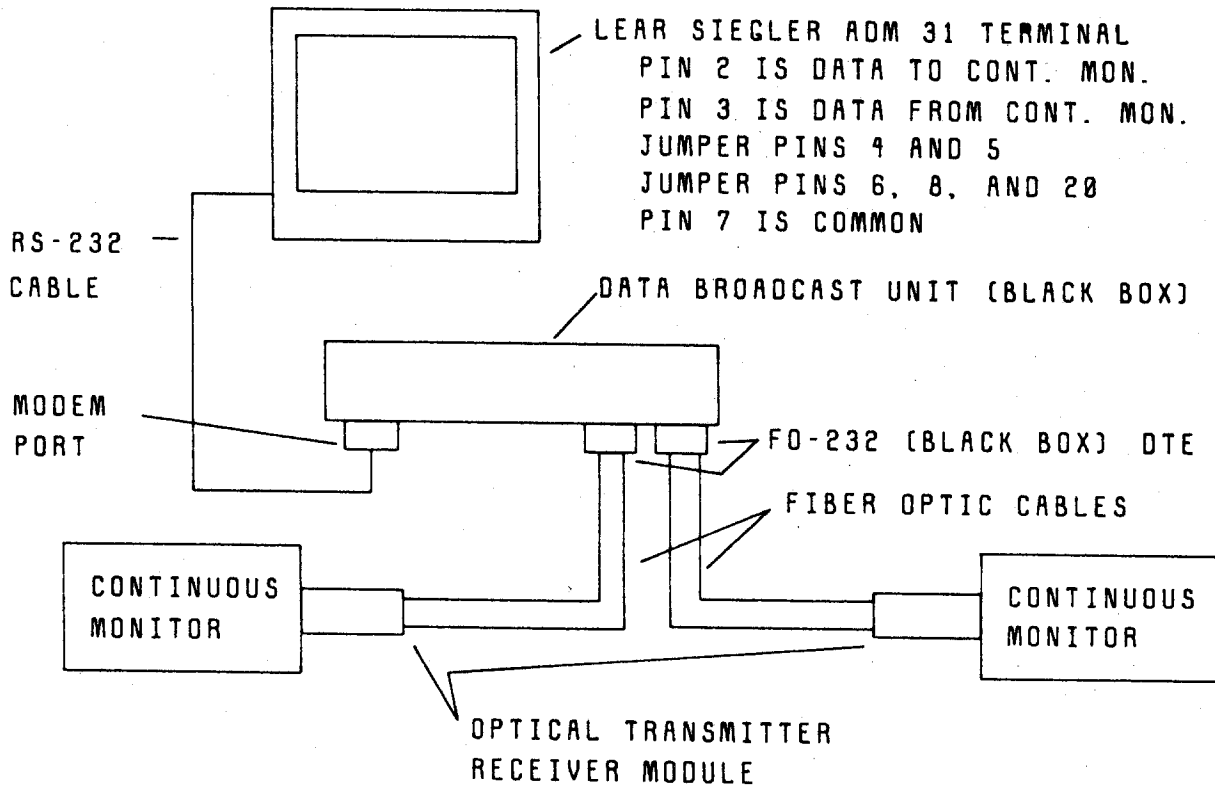

**Figure CM-5 (0285A9837-1) Connection for Multiple Continuous Monitors**

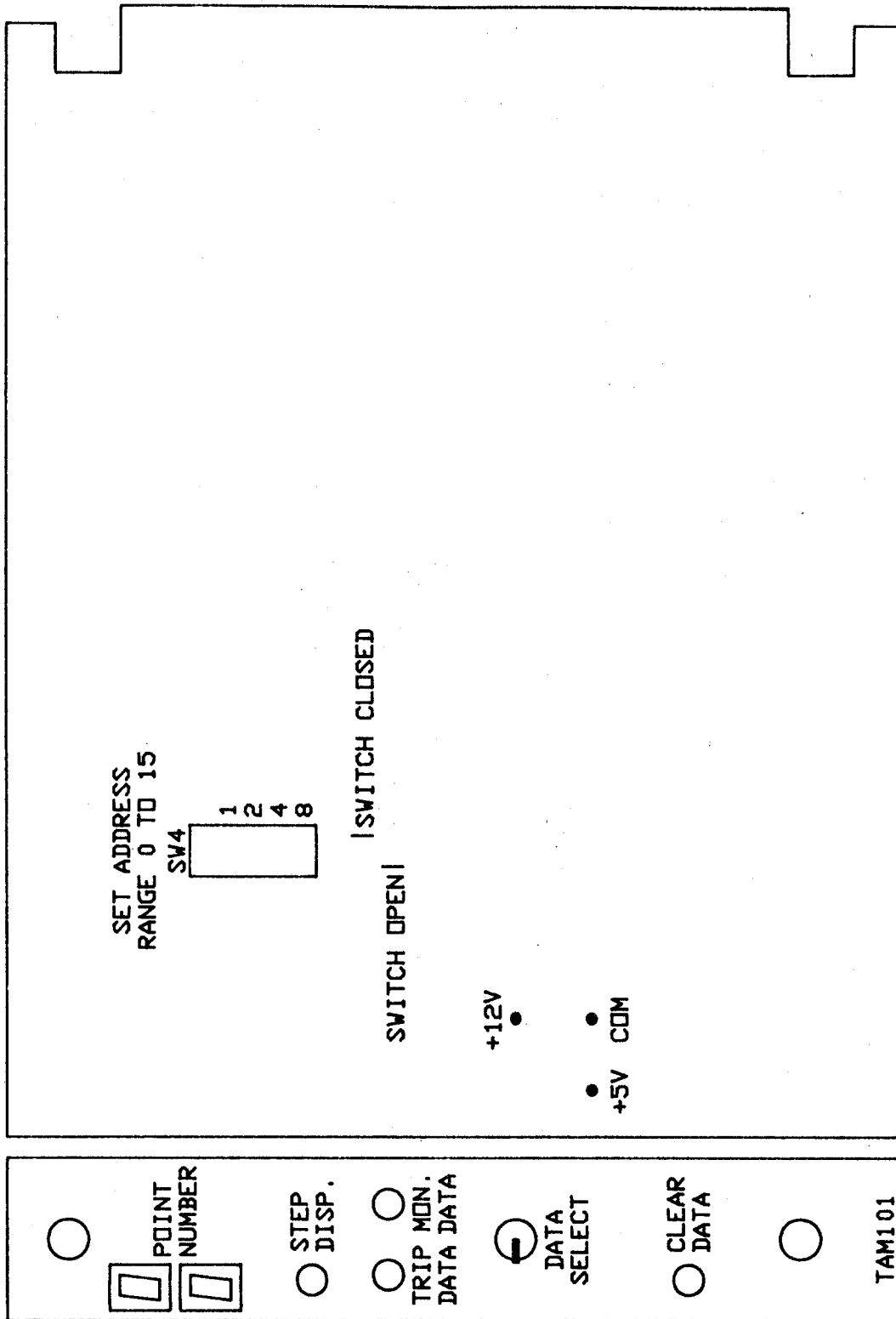

Figure CM-6 (0285A9831-3) Front Panel & Internal Switches, TAM101



## SOFTWARE

The following two programs are provided on two 5.25 inch disks. One 3.5 inch disk containing both programs will be supplied upon request.

### 1. SETTYS.exe

This program can be used as an aid in determining the settings for any of the available TYS3 relaying systems. After the program has been run, a complete listing of all of the settings will be provided, by module. This listing can be viewed on the screen; it can be printed out if a printer is available.

Revision "B" TYS2 relays require version 2.xx of SETTYS.

### 2. TYSTEST.exe

This program can be used to calculate specific test values to be used in testing the TYS3 system with any specific setting.

After the program has been run, a complete listing of the test values will be provided. This listing can be viewed on the screen, or it can be printed out if a printer is available.

### Running the programs

An MS-DOS-compatible computer is required to run either of the programs. The computer must be booted up before either of the programs can be run. To run either program, insert the appropriate disk in the drive to be used and then type the following:

d:name

where,

d = drive where program disk is inserted

name = SETTYS, or TYSTEST



# RECLOSER

## INTRODUCTION

The RLM131 module can be used to reclose a breaker up to four times following tripping by protective relays. The RLM131 module can be set to provide one instantaneous (no intentional delay) and three time-delayed reclosures. Any, or all, of the reclosures can be disabled.

Typical external connections to the RLM131 module are shown in Figure RE-1.

## DESCRIPTION

### Basic Operation

The RLM131 module is microprocessor controlled and designed for use in the reclosing of a circuit breaker following tripping by protective relays. Up to four reclosures can be selected, with one being instantaneous and the other three being settable over various time ranges. Other features, to be discussed subsequently, are also included.

A Liquid Crystal Display (LCD) is included in the relay to display all settings that are directly programmable on the front panel of the relay. Programming is done via a set of 4 CODE switches, a set of 4 NUMBER switches, and an ENTER button (see Figure RE-2 for details). The CODE switches (set to 1 or 0) are used to select which setting is to be made, whereas the NUMBER switches (set to IN or OUT) are used to make the actual setting. After the CODE and NUMBER switches have been set, the ENTER button is pushed to store the setting in the relay.

For example, to select all four reclosures, CODE (0 0 0 0) is selected by placing the four CODE switches in the "0" position, and then placing all four of the NUMBER switches in the "IN" position to

indicate that all four reclosures are required. If all four reclosures are not required, the same CODE would be selected, but the NUMBER switches of the unwanted reclosures would be left in the "OUT" position. Next, the ENTER button would be pushed to enter the settings. All other settings are made in a like manner by first selecting the appropriate CODE, then selecting the NUMBER, and finally pushing the ENTER button. Further details on the remaining settings can be found under the Settings section.

Please note that the recloser is not enabled until all of the CODE switches are placed in the "1" position and the ENTER button pushed. The CODE switches must all then be left in the "1" position for the recloser to remain enabled. If any of the switches are set to "0", the recloser will be disabled and will not respond to any external input commands. Note that if any of the switches are set to "0", the LCD display will be blank, indicating that the recloser is disabled. When the recloser is enabled, it will display RES if it is in reset or LO and BI if it is in lockout.

It is possible to change one or more of the settings without reprogramming the entire sequence. To do this, simply select the required CODE(s) and NUMBER(s) followed by an ENTER. After the changes have been made, return all of the CODE switches to the "1" position and push ENTER to enable the recloser.

After all of the settings have been made they can be checked by pushing the READ button, which will cause the settings to be sequentially displayed in the LCD (see READ section). It is also possible to have the recloser perform a self-test by pushing the TEST button, which will cause the recloser to go through its operating sequence but without energizing the output relays (see TEST section). The READ and TEST buttons can be pushed at

RE

any time, without the need for removing the recloser from service. If a reclosing operation is called for during either the TEST or the READ sequence, they will be overridden and the recloser will then run through its normal operating sequence.

Once the recloser is enabled, operation is controlled by the breaker auxiliary "a" and "b" switches and the breaker control switch 52CS. Please refer to Figure RE-1, which shows typical external connections to the RLM131 module.

If the breaker is closed when the recloser is enabled, it will recognize that the "a" switch is closed, and that the "b" switch is open, and will "awaken" in the reset (RES) position. RES will be displayed in the LCD. On the other hand, if the breaker is open when the recloser is enabled, the auxiliary switches will be in the opposite state; the recloser will recognize this and it will "awaken" in the lockout (LO) position. LO and BI will be displayed in the LCD. When the breaker is closed manually, the auxiliary switches will transfer state ("a" closes, "b" opens) and the recloser will start to count down from a time equal to the reset setting (this can be observed in the LCD). At the end of the reset period, the recloser will assume the reset position and RES will be displayed in the LCD. If, on the other hand, the breaker were to trip as the recloser was counting down, the auxiliary switches would again change state and the recloser would immediately go to the lockout position, thus preventing any further reclosures. At that time, LO and BI would be displayed in the LCD.

If the breaker is tripped manually, the recloser will count down to the first reclosure selected (no countdown if instantaneous was selected) and at that time will produce an output to reclose the breaker. No reclosure will take place, however, because the 5-5C contacts of the control switch (52CS) will be open at that time. At the instant that the reclose output is produced, the recloser will check to see whether the breaker auxiliary switches transfer; i.e., "b" opens and "a" closes. This transfer must occur within a time that is equal to

(0.9) times the TIME MULTIPLIER in seconds (see Set Time Multiplier under Programming). Thus, if a TIME MULTIPLIER of 1.0 is selected, the transfer of the auxiliary switches must occur within 0.9 seconds after a reclose output is produced. If the transfer does not occur within this time period, the recloser will immediately go to lockout. Since reclosing is prevented by the control switch following a manual trip, the recloser will go to lockout following any manual trip. **NOTE THAT THE ABOVE-DESCRIBED TIME LIMIT APPLIES ANY TIME THAT THE RECLOSER PRODUCES A RECLOSE OUTPUT.**

If the breaker is tripped by the protective relays, the 5-5C contacts of the control switch will be closed, and the recloser will go through its programmed sequence following closure of the "b" switch. When the first reclosure point is reached, a reclose output will be produced to close the breaker. If the breaker closes successfully, as indicated by a transfer of the auxiliary switches within the specified time limit, the recloser will start to count down to reset. If no tripping occurs during this period, the recloser will reset and be ready to initiate another complete reclose cycle when called for. If a trip does occur during the reset period, the recloser will then go on to the next reclosure, if one has been selected.

If the breaker retrips following each reclosure, the recloser will go through its complete cycle. Following the last selected reclosure, the recloser will immediately go to lockout when the breaker retrips. Note that the recloser starts a new timing cycle during each reclose period; i.e., the reclose times are not cumulative and do not start from the time that the breaker is first tripped.

### Additional Features

The following additional features are also included in each RLM131. Typical applications for each of these features will be discussed separately in the APPLICATION section.

A Delayed Reclose (DR) input is included to allow the first selected



reclosure to be skipped and to go directly to the next reclosure. For example, if the INSTANTANEOUS, FIRST and THIRD reclosures were selected, an input (contact closure) at the DR input would cause the instantaneous reclosure to be skipped, and the recloser would go directly to the FIRST reclosure.

A "PAUSE" feature is provided that can be used to control a reclose output and/or the reset time of the relay as follows:

1. When used in the reclose mode, a reclose output will be delayed for up to the PAUSE setting, or until a contact is closed at the PAUSE input to the relay. If a contact closure occurs during the PAUSE period the reclose output will be produced immediately; otherwise the relay will go directly to lockout at the end of the PAUSE period. In other words, the relay cannot produce a reclose output unless the PAUSE input is present at the time a reclose is called for, or unless a PAUSE input is applied during the PAUSE period. Note that the PAUSE period begins at the time that a reclose output would normally occur. For example, if a 16 second PAUSE setting were selected, the recloser would count down to each reclosure, and at that time would reclose the breaker if a PAUSE input was present (contact closed), or would wait 16 seconds from that time for a PAUSE input to be applied. If a PAUSE input was applied during that time, reclosing would occur immediately; otherwise lockout would occur when the pause time elapses.
2. When used in the reset mode, the reset time can be delayed for up to the pause setting. Here too, the PAUSE time will be initiated if there is no PAUSE input, and the PAUSE time will be prevented, or terminated, by a contact closure at the PAUSE input to the relay. In other words, a continuous PAUSE input will produce the reset times stored in memory. On the other hand, the reset time can be extended by up to the PAUSE time, or for a lesser time, by controlling the time that the PAUSE

input is open during the reset period. For example, with a PAUSE setting of 16 seconds, the reset time can be extended for 16 seconds, or less, by opening a contact at the the PAUSE input. If the contact is open for 16 seconds or longer, the reset time will be extended by 16 seconds. If the contact is open for a lesser time, then the reset-time extension will be equal to the time that the the contact is open. The PAUSE input (contact opening) can be applied at any time during the reset period.

An option plug is provided wherein the PAUSE feature can be ignored altogether (Position 3 to 4), used for reclose only (Position 1 to A), used during reset only (Position A to 2), or used during both reclose and reset (Position 2 to 3). Only one PAUSE setting can be made, and it applies to both the reclose and/or reset period; i.e., independent pause settings cannot be made if both the reclose and reset modes of operation are chosen for the PAUSE feature.

Output contacts, designated RS (Relay Spare), are provided for use in external control circuits. The RS contacts can be set to be activated at any one, but only one, of the selected reclosures. The RS contacts can be set to operate with a pickup delay and dropout delay if desired. These delays are measured starting at the reclosure selected to activate RS. For example, if RS is set to operate at the second reclosure and with a pickup time of 2 seconds and a dropout time of 6 seconds, the following will occur:

When the reclose signal is applied to the breaker at the end of the second reclose period, the RS function will pick up 2 seconds later, remain picked up for 4 seconds, and then drop out. Thus, the time that the RS function remains picked up is equal to the set dropout time minus the set pickup time, because both timing periods are started at the same time.

Output contacts, designated BI (Block Instantaneous), are provided for use in

external control circuits. These contacts operate with the first selected reclosure signal, and remain picked up until the recloser resets. For example, if the SECOND and THIRD reclosures are selected, the BI function will operate when the second reclosure times out and produces a reclose signal to the breaker. The BI function will stay up until the recloser is reset. If the reclosure attempts are unsuccessful, the recloser will go to lockout and the BI function will stay up. In fact, the BI function will be picked up any time the recloser is in lockout, and it will stay picked up until the recloser is reset.

Output contacts, designated IP (In Progress), are provided for use as an indication that a reclosing operation is in progress. The IP function will be energized except when the recloser is completely reset or in lockout.

Output contacts, designated LO (Lockout), are provided for use when the recloser is locked out. The LO function will be energized only when the recloser is in the locked out position.

A TIME MULTIPLIER is included in the RLM131 module, wherein the range of all of the time settings can be changed. Figure RE-2 lists the times for a TIME MULTIPLIER setting of 1.0. Note that the TIME MULTIPLIER setting applies to all times, including the reclose limit time described earlier; i.e., it is not possible to change just one time range via the TIME MULTIPLIER.

APPLICATION

The RLM131 module can be used to close a circuit breaker up to four times following tripping by protective relays. Any, or all, of the reclosures can be selected. If all four reclosures are selected, the first reclosure will always be instantaneous, followed by three time-delayed reclosures. If three, or less, reclosures are selected, all three may be time delayed, or one instantaneous reclosure followed by one or two delayed reclosures may be used. The instantaneous reclosure has no intentional time delay. The remaining reclosures and the reset time can be set over the time ranges shown in Table RE-I.

Note that the time multiplier works on all time ranges concurrently; i.e., it is not possible to change only one time range. The multiplier has no effect on the instantaneous reclosure.

Typical external connections to the RLM131 module are shown in Figure RE-1. This diagram illustrates the connections to be used in simple, straightforward applications without any special requirements such as synchronism check, delayed reset, etc. These special requirements will be discussed separately. A breaker control switch (52CS), and breaker auxiliary "a" and "b" switches are required, as shown in the connections. A control switch contact (5-5C) that is closed only in the "close" and "normal after close" positions is employed, to prevent automatic

TABLE RE-I

RECLOSURE	TIME RANGE SECONDS	RESOLUTION	MULTIPLIER
FIRST	0.1 TO 15.9	0.1	0.5, 1.0, 2.0, 4.0
SECOND	1.0 TO 159	1.0	
THIRD	1.0 TO 159	1.0	
RESET	1.0 TO 159	1.0	

reclosing of the breaker following a manual trip. With this switch arrangement, the relay will sense that reclosing is being prevented, and it will go to lockout when it tries to close the breaker following a manual trip.

The RLM131 module has many unique features, and a great deal of flexibility in how they may be employed. Following is a description of these features, along with some special applications in which they can be used. The figures used in these descriptions apply only to the pertinent input connections. Refer to the overall elementary, Figure RE-1, for the remainder of the connections.

### Block Instantaneous Tripping

It is sometimes desirable, on distribution circuits, to block the instantaneous trip circuits after the first trip, but before the first reclosure is called for, thus providing for coordination with branch circuit fuses. This can be implemented with the normally-closed "BI" contact, as shown in the simplified connection diagram of Figure RE-3. The diagram represents an application with time overcurrent (TOC) and instantaneous overcurrent (IOC) functions. Note that the BI contact opens at the first selected reclosure, and stays open during the remainder of the reclosing cycle, and in the lockout position if reclosing proves to be unsuccessful. A contact of the breaker control switch is shown connected across the BI contact. This control switch contact, which is closed in the "close" position of the switch, is used to re-establish the instantaneous trip circuit when the breaker is manually reclosed with the RLM131 module in the lockout position.

It is also possible to use the normally-closed "RS" contact to block instantaneous tripping. In this case, RS can be set to pick up after the first, or even the second, delayed reclosure and thus allow instantaneous tripping to occur two, or even three times rather than just once, as can be done with the BI contact. Note that the RS function is dropped out at the lockout position; thus, instantaneous

tripping is re-instated at that time, and it is not necessary to use the control switch contact described earlier.

### Selective Reclosing

In some applications it may be desirable to initiate instantaneous plus delayed reclosures following a high-speed trip, but to allow delayed reclosures only, following a time-delayed trip. This can be accomplished by applying a signal from the time-delay trip bus to the "DR" input of the RLM131 module, as shown in Figure RE-4. With this connection, the recloser will skip the instantaneous reclosure (or the first selected reclosure) and go immediately to the next selected reclosure. It is possible to use the high-speed reclose-initiate (RI) output from the protective relaying scheme to initiate the reclose cycle, but it must be paralleled by a breaker "b" switch contact, as shown in Figure RE-4, to ensure completion of the reclose cycle.

It is also possible to set the RLM131 module to provide two separate single-shot reclosures, with each reclosure having a different time delay. For example, it might be desirable to provide a single-shot of reclosing with a long time delay for ground faults, but to provide a single-shot of faster reclosing for phase faults. This can be accomplished via the connections shown in Figure RE-5. Assume, as an example, that a single-shot instantaneous reclosure is required following phase faults, but that a single-shot time-delayed reclosure is required following ground faults. To do this, make the connections shown in Figure RE-5 with a contact from the ground-fault-detection circuit connected to the DR input (select single-shot No. 2) input of the RLM131 module. Make the following settings:

1. Select instantaneous (INST.) and first (1ST) reclosure.
2. Set the FIRST reclosure time delay to that required for groundfaults.
3. Set the PAUSE-select jumper to the 1 to A (RECLOSE) position

RE

4. Set the PAUSE time setting to zero (0)
5. Set an appropriate reset time.

With these connections and settings the following will occur.

1. For phase faults - when a phase fault occurs, there will be no DR input to the RLM131. Consequently, when the breaker trips and the "b" switch closes, the RLM131 will initiate an instantaneous reclose output to close the breaker. At the same time, the BI contacts will open to remove the PAUSE input. If the reclosure is successful, the RLM131 will reset following the set reset time (BI contacts will close at that time). If the reclosure is not successful and the breaker retrips, the RLM131 will count down the first reclose time and then try to close the breaker. Reclosing will not be permitted, however, because of the open PAUSE input, and the RLM131 will then immediately go to lockout. Thus, only one reclosure is permitted.
2. For ground faults - when a ground fault occurs, there will be an input applied to the DR input of the module (must be applied before "b" closes). At that time, the instantaneous reclosure will be skipped and the RLM131 will start to count down to the first reclosure when the "b" switch closes. The breaker will thus be closed following a delay equal to the first reclose time. If the reclosure is successful the RLM131 will go to reset. If the breaker retrips, the RLM131 will go immediately to lockout. Here too, only one reclosure is allowed.

### Synchronism Check

Synchronism check may be used with the RLM131 reclosers via the PAUSE input, as shown in Figure RE-6. In this connection, the synchronism check contact must be closed when the system is in synchronism, and open when the system is out of synchronism. Thus, when a reclose is called for it will be permitted if the system is in synchronism, or blocked if the system is out of synchronism. The PAUSE

time setting is the time that is permitted for a sync-check input to be produced, and is started when a reclose output is called for. If a sync-check input is not present when the PAUSE time elapses, the RLM131 will go immediately to lockout. Note that a sync-check input is required at all selected reclosures when the PAUSE function is implemented.

If it is desired not to sync check a reclosure, some means must be used to bypass the sync-check input at the reclosure where sync check is not wanted. For example, the RS normally-closed contact may be used to eliminate the sync-check requirement for an instantaneous reclosure, by connecting it as shown dotted in Figure RE-6. For this connection to be effective for the described condition, RS must be set to pick up shortly after the instantaneous reclosure (1 second for example) and to drop out at lockout. In this way sync check will be required on all delayed reclosures, but not on the instantaneous reclosure.

### Delayed Reset

Some applications may require a delay in (extension of) the reset time, to allow certain events to occur before the RLM131 is allowed to go to reset. For example, it may take a time-overcurrent function a very long time to operate for low-level ground faults, whereas the phase time-overcurrent functions may operate very quickly. Thus, long reset times may be required to accommodate the low-level ground faults, whereas shorter reset times may be required for phase faults. The PAUSE input to the RLM131 relays can be used to accomplish this requirement. A simplified connection diagram to meet this requirement is shown in Figure RE-7. Note that a sensitively set instantaneous-overcurrent (IOC) function and an auxiliary-function 79X are required. With this connection, the PAUSE input will be open whenever IOC operates. The PAUSE time will last as long as IOC is picked up, or until the PAUSE time elapses; and the reset time will be extended accordingly. In this way time will be allowed for the TOC to operate before the RLM131 resets.

**PAUSE Function - Dual Use**

Two separate and distinct applications have been described using the PAUSE function: a. synchronism check during reclose, and; b. delay during reset. It is possible to use the PAUSE function during both reclose and reset, but special connections are required, as shown in Figure RE-8. Note that although the sync-check and reset-delay functions are totally isolated in this example, they both operate for a common PAUSE time; i.e., it is not possible to use separate PAUSE time settings when the PAUSE function is used for a dual purpose.

**OPERATION**

**RLM131 Inputs and Outputs**

The Recloser has 4 inputs and 5 outputs as listed below.

**Inputs:**

- DR "Delayed Reclose" is used to skip the first selected reclose signal.
- P "Pause" is used to delay the start of the reclose signal, or to extend the reset time, or both.
- 52a, 52b Auxiliary contacts of the circuit breaker, used to indicate the state of the breaker.

**Outputs:**

- IP "In Progress" is used to indicate that the recloser is in progress for a reclose or reset.
- RS "Relay Spare" is an auxiliary relay that can be operated at any selected reclose, with adjustable pickup and dropout times.
- LO "Lockout" is used to indicate the relay is in lockout.
- BI "Block Instantaneous" operates at the first reclose

signal and remains on until the recloser is reset.  
 REC "Reclose" is the reclose signal.

**Time Multiplier**

A Time Multiplier is included in the RLM131 recloser, wherein the range of all of the time settings can be changed. The setting table (Figure RE-2) for the relay lists the times for a time multiplier setting of 1.0. Note that the time multiplier setting applies to all times, including the reclose-limit time described earlier on page RE-2 and again on page RE-9; i.e., it is not possible to change just one time range via the time multiplier.

**Printed-Circuit-Board Assembly**

The printed-circuit-board assembly includes the large circuit board perpendicular to the front panel and the small control circuit board immediately behind the front panel (see Figure RE-9), which are connected together with three 18-conductor jumper cables.

The large circuit board consists of the following circuits:

1. Input relay circuits for the 4 input signals.
2. A 5 VDC power supply for the system logic.
3. The output relay driver circuits and the output relays, except for the reclose relay.
4. Jumper plug (pause control) to select the pause function.
5. Jumper plug (SLS/TLS) to select the active high or low of the reclose relay.
6. Jumper plugs (input voltage selection 48, 110/125, 220/250) to select the input voltage for input relays K1, K2, K3 and K4.



The front panel and the control circuit board immediately behind it consist of the following:

1. Input switches to program the reclose functions.
2. Input push buttons to read and test the reclose functions that are programmed in.
3. The liquid crystal display and reclose light-emitting diode.

Making the RLM match your system, and determining how the "Pause" will function, are implemented on the RLM module's large-size board, with the module removed from the case; this is covered in the Settings section.

Making the RLM carry out the desired pattern of reclosures is implemented on the front panel, with the module in place in the case, and is covered in the Programming, Read and TESTING sections.

**Settings**

Remove the RLM module from the case; on the recloser circuit board, select the positions of jumper plugs as follows.

Set the 4 jumper plugs for the input relays (K1, K2, K3, K4) to the correct system voltages.

Set the pause control to select whether a pause is to be used, or where in the reclose cycle the pause function is to operate.

1. If the pause control is set 1 to A, the pause will occur just prior to the reclose signal when the pause input to the RLM131 is open.
2. If the pause control is set A to 2, the pause will occur during the reset time when the pause input to the relay is open.
3. If the pause control is set 2 to 3, a pause can be called for at reclose

and during reset.

4. If the pause control is in the 3 to 4 position, the pause function is locked out.

The pause function is set up so that only one pause can occur per reclose or reset.

Set the SLS/TLS for the reclose relay provided on the basic relay. If the relay requires a high signal (such as the TLS and TYS) set the jumper to TLS. If the relay requires a low signal (such as the SLS) set the jumper to SLS.

Restore the RLM module to its place in the case.

**Programming**

In order to program settings, the RLM131 must be powered up, and in either reset or lockout. A change in CODE from 1 1 1 (see Figure RE-2) when the relay is in progress will be ignored until the relay reaches the reset or lockout condition. Programming is accomplished, on the front panel, by selecting the code of the function, setting the number, and pushing ENTER. Push READ to verify a setting. (The operation of the READ switch is covered in the Read section.)

When the code is anything but 1 1 1 1, the relay will not respond to input changes, and the outputs are inhibited from changing state.

**1. Select Reclosures**

	<u>CODE</u>	<u>NUMBER</u>	
RECLOSE	0 0 0 0	3rd 2nd 1st	INST.

There are 16 combinations of RECLOSE settings, all of which are valid. INST. is the instantaneous reclose signal (no intentional time delay on reclose). The 1st, 2nd and 3rd reclosures occur after an adjustable time delay. All reclosures not selected are skipped. If none of the reclosures are selected, (all numbers of the CODE entered in the OUT position), the recloser will go to lockout when the 52b contact closes.

**2. Set First Reclose Time**

	<u>CODE</u>	<u>NUMBER</u>	
FIRST	[ 0001 ]	8 4 2 1	] SUM
	[ 0010 ]	.4 .2 .2 .1	] SUM

The FIRST (1st) reclose time can be set from .1 to 15.9 seconds. If no time is selected (all numbers of each CODE entered in the OUT position), the delay will be .1 second. The time is selected in 2 bytes. *If 8 and 2 are entered for CODE 0001 and .4 and .2 are entered for CODE 0010, the time setting will be 10.6 seconds.*

**3. Set Second and Third Reclose Times and Reset Time**

	<u>CODE</u>	<u>NUMBER</u>	
SECOND	[ 0011 ]	80 40 20 10	] SUM
	[ 0100 ]	4 2 2 1	] SUM
THIRD	[ 0101 ]	80 40 20 10	] SUM
	[ 0110 ]	4 2 2 1	] SUM
RESET	[ 0111 ]	80 40 20 10	] SUM
	[ 1000 ]	4 2 2 1	] SUM

The SECOND (2nd) and THIRD (3rd) reclose times, along with the RESET time, can be set from 1 to 159 seconds. If no time is selected for the SECOND reclose, THIRD reclose or RESET time (all numbers of each CODE entered in the OUT position), the delay will be 1 second.

**4. Set Time Multiplier**

	<u>CODE</u>	<u>NUMBER</u>	
TIME MULTIPLIER	[ 1001 ]	4 2 1 .5	] SELECT ONE

The TIME MULTIPLIER multiplies the following time settings by the NUMBER selected.

- A. First reclose time
- B. Second reclose time
- C. Third reclose time
- D. Reset time
- E. Pause time
- F. RS dropout time
- G. RS pickup time
- H. †Reclose signal time limit

\* Revised since last issue

† The reclose signal time limit is the time allowed for the breaker to close following a reclose signal. If the breaker does not close in that time, as indicated by the transfer of the breaker "a" and "b" switches, the relay will go directly to lockout. The reclose time limit with a 1.0 multiplier is 0.9 seconds.

Only one MULTIPLIER should be selected. If more than one MULTIPLIER is selected, the highest of the selected MULTIPLIERS will be used. If no MULTIPLIER is selected (all numbers of the CODE entered in the OUT position), the MULTIPLIER will be 4.

**5. Set Pause Time**

	<u>CODE</u>	<u>NUMBER</u>	
PAUSE	[ 1010 ]	1024 64 4 0	] SELECT ONE
	[ 1011 ]	∞ 256 16 1	] SELECT ONE

Pause can be used to delay the start of a reclose signal output or to insert a time delay in the reset time. The time set is a limit on the PAUSE signal. Only one PAUSE limit of the eight should be selected. In order to be sure only one PAUSE limit is set, the CODE position not used should be entered with all values OUT. If more than one PAUSE limit is selected, the highest of the selected values will be used (∞ is considered the highest value). If no PAUSE limit is selected (all numbers of the codes entered in the OUT position), the pause limit will be 1024 seconds.

**6. Set RS Pickup, Dropout and Operate Point**

	<u>CODE</u>	<u>NUMBER</u>	
-DROPOUT	[ 1100 ]	L 24 12 6	] SELECT ONE
-PICKUP	[ 1101 ]	4 2 1 0	] SELECT ONE
-RS	[ 1110 ]	3rd 2nd 1st INST	] SELECT ONE

The RS "Relay Spare" is an output signal that is selected to operate at, or with a time delay from, one of the four reclose signals. The PICK UP and DROP OUT time delays both start at the selected reclose. (If DROP



# RECLOSER

OUT is set at 6 and PICK UP is set at 4 and RS is set at 2nd, the RS output will operate 4 seconds after the 2nd reclose and stay picked up for 2 seconds).

If L is selected for dropout, the RS output signal will stay up until lockout.

If more than one RS position is selected, the earliest will be used. (If the 2nd and INST. were selected, INST. would be used.) If RS is selected in an unused reclose position, the nearest reclose that is earlier in the reclose cycle would be selected.

If RS is set at INST. and instantaneous is skipped because of a DR "Delayed reclose" input, the RS timing will start with the 52b input signal.

If more than one PICK UP time is selected, the highest selected time will be used. If a PICK UP time is not selected, 0 will be used.

If more than one DROP OUT time is selected, the highest selected time will be used. (L will be considered the highest DROP OUT time). If a DROP OUT time is not selected, L will be used.

When the recloser goes to lockout, the RS output signal will drop out. (RS drops out immediately with LO, and is not contingent on any PICK UP or DROP OUT timing.)

If RS is selected for an earlier time in the reclose cycle than the earliest reclose, the RS output will be picked up, except when the recloser goes to lockout. For this condition, L is substituted for whatever was programmed in the RS dropout CODE position.

## 7. Enable Recloser

	<u>CODE</u>	<u>NUMBER</u>
OPERATE	1111	

After the 15 lines of CODE are entered, the CODE must be set at 1 1 1 1 and ENTER pushed for the recloser to operate.

## Read

The data programmed into the recloser is read out on the LCD display when the READ pushbutton is operated. The data is displayed in 8 readings of 4 seconds each. Any function not used is skipped, which shortens the read cycle. The following is a description of each 4 second read.

### 1. Reclosure selected

All reclosures selected will be on solid, and REC. will blink for the 4 seconds.

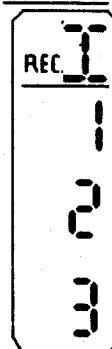

Readout for a 4-shot recloser (instantaneous and 3 timed)

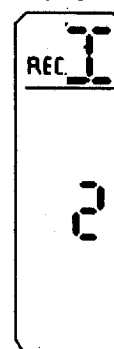

Readout for a 2-shot recloser (instantaneous and 1 timed)

### 2. Time of reclose (1st)

The number of the timed reclosure (1) along with the time will be on solid, and REC. will blink for 4 seconds.

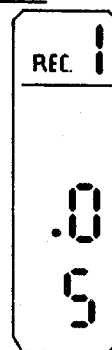

1st timed reclosure set at .05 seconds

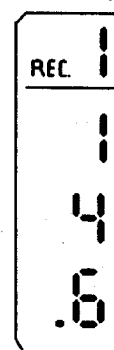

1st timed reclosure set at 14.6 seconds



3. Time of reclose (2nd)

The number of the timed reclosure (2), along with the time, will be on solid, and REC. will blink for 4 seconds.

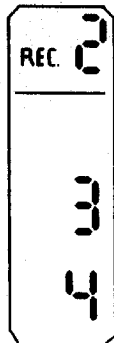
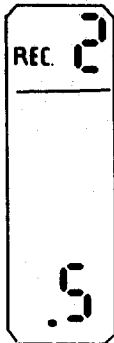

2nd timed reclosure set at .5 seconds

2nd timed reclosure set at 34 seconds

4. Time of reclose (3rd)

The number of timed reclosure (3), along with the time, will be on solid, and REC. will blink for 4 seconds.



3rd timed reclosure set at 60 seconds

3rd timed reclosure set at 107 seconds

5. Time of reset

The time for reset will be on solid, and RES. will blink for 4 seconds.



Reset time set at 89 seconds

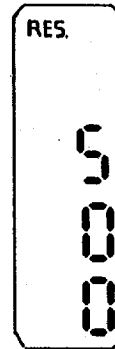

Reset time set at 500 seconds

6. Time of pause limit

The time for pause will be on solid and pause will blink for 4 seconds.

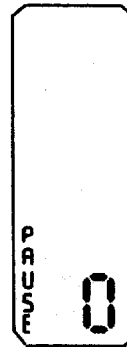

Pause limit set at 0 seconds (reclose only)

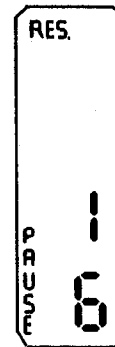

Pause limit set at 16 seconds (\*)

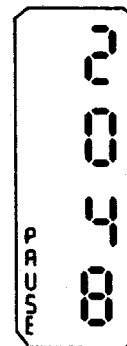

Pause limit set at 2048 seconds (reclose only)



Pause limit set at ∞ (†)

† If RES. is on solid, pause is for reset only, and if RES. is blinking, pause is for reclose and reset. If RES. is not on, pause is for reclose only.



7. Pickup and dropout time of RS  
 The pickup and dropout times will be on solid, and R.S. and D.O. will blink for 4 seconds.

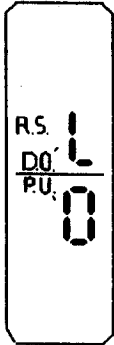

Pickup set at 0 and dropout set for lockout of the recloser

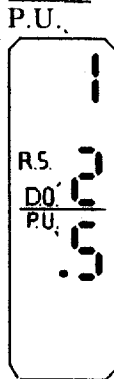

Pickup set at 0.5 seconds and dropout set at 12 seconds

8. Reclose position of RS  
 The RS start position will be on solid, and R.S. will blink for 4 seconds.

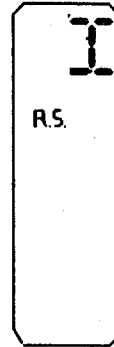

Timing of RS set to start with the INST. reclose signal

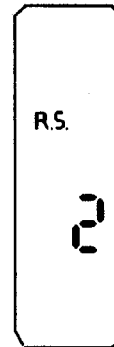

Timing of RS set to start with the 2nd reclose signal

**Power Up**

When the recloser is powered up it will be in lockout if the circuit breaker is open, and in reset if it is closed.

TABLE RE-II  
INTERRUPTING RATINGS OF AUXILIARY RELAY CONTACTS

Relays K1, K2, K3, and K4

ARRANGEMENT	1 FORM A - 1 FORM B
CONTACT MATERIAL	GOLD FLASH OVER SILVER ALLOY
INITIAL CONTACT RESISTANCE, MAX.	30 milli-ohms
RATINGS (RESISTIVE)	
Max. Switching Power	AC--2000 VA, DC--50 W
Max. Switching Voltage	250 VAC
Max. Switching Current	8 A
HP Rating	1/4 HP 125, 250 VAC

**Ratings**

The RLM131 is DC-operated, with input voltage ratings of 48, 110/125 and 220/250 volts DC. The interrupting ratings of the auxiliary relay contacts are shown in Table RE-II. If the interrupting rating is exceeded on any of the RLM131 output relay contacts, a suitable breaker contact or interposing relay must be used.

The output relays have make-and-carry ratings of 3 amperes continuously, and 30 amperes for 0.2 second.

**TESTING**

**Recloser Self Test**

The self-test circuit of the recloser is designed to test the electronics of the system while running the program information entered into memory. The test system operates all circuits except the

input networks and output relays. During the test, the RLM131 assumes that the circuit breaker is working into a fault so that each time the circuit breaker closes it will open immediately. During the test, the output relays do not change state. Reclose signals are indicated by the reclose LED (green light-emitting diode).

If the circuit breaker is closed during test, (52a closed and 52b open), the relay will time down all the reclose operations programmed in, wait 4 seconds in lockout, do a manual close, and count down the reset time.

If the circuit breaker is open during test, (52a open and 52b closed), the relay will do a manual close, count down the reset time, wait 4 seconds in reset, and time down all the reclose operations programmed in.

A DR "Delayed Reclose" signal can be added to the test cycle by holding the TEST button down for more than 1 second. The normal test is started by holding the TEST button down for less than 1 second.



RECLOSER

During test, all function messages on the LCD blink (RES., REC., R.S., B.I., L.O.).

The following are some typical LCD displays as test proceeds from reset to lockout and back to reset.

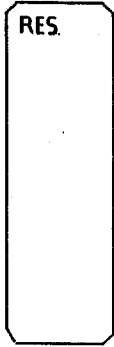

Normal reset condition. R.S. could be ON if it was set earlier than the first reclose. RES. not blinking

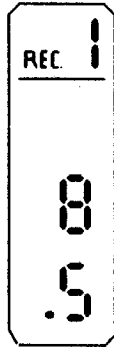

1st timed reclose counting down in .5 second intervals. REC. is blinking. B.I. not being energized indicates that instantaneous reclose was not called for, or the test button was held for more than 1 second, causing a DR input signal.

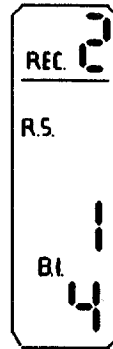

2nd timed reclose counting down in 1 second intervals. REC., R.S. and B.I. are blinking. R.S. being on could be from being time delay, or being set at 1st.

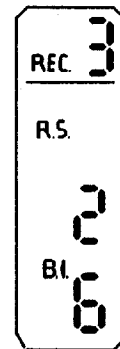

3rd timed reclose counting down in 1 second intervals. REC. and B.I. are blinking. R.S. being off indicates the dropout time has timed out.

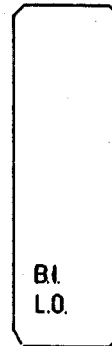

Relay is now at lockout for 4 seconds, B.I. and L.O. are blinking



A manual close has occurred and the reset time is counting down in 1 second intervals. RES., B.I. and L.O. are blinking.

After the reset time is counted down, the test is complete and the LCD will show RES.

**Functional Test**

In order to run the functional test per Figure RE-10, set up and program the recloser as follows:

1. Set the pause control for 3 to 4 and SLS/TLS to the correct setting on the recloser circuit board (see Figure RE-9).
2. Put the RLM131 in its slot in the case

and energize the test circuit and recloser.

3. The RLM131 should be in lockout with B.I. and L.O. appearing on the LCD. Relays BI "block instantaneous" and LO "lockout" will be picked up.
6. Program the relay as shown in Table RE-III.

TABLE RE-III

	CODE	NUMBER					
A.	0000	IN	IN	IN	IN	push ENTER	- All reclosures in (4)
B.	0001	OUT	OUT	OUT	OUT	push ENTER	} SUM for 1st = .5
C.	0010	IN	OUT	OUT	IN	push ENTER	
D.	0011	OUT	OUT	OUT	OUT	push ENTER	} SUM for 2nd = 1
E.	0100	OUT	OUT	OUT	IN	push ENTER	
F.	0101	OUT	OUT	OUT	OUT	push ENTER	} SUM for 3rd = 2
G.	0110	OUT	OUT	IN	OUT	push ENTER	
H.	0111	OUT	OUT	OUT	OUT	push ENTER	} SUM for RES. = 3
I.	1000	OUT	OUT	IN	IN	push ENTER	
J.	1001	IN	OUT	OUT	OUT	push ENTER	- Multiply all times by 4
K.	1010	IN	OUT	OUT	OUT	push ENTER	} Pause selected = 1024
L.	1011	OUT	OUT	OUT	OUT	push ENTER	
M.	1100	IN	OUT	OUT	OUT	push ENTER	- RS Dropout at lockout
N.	1101	OUT	OUT	OUT	IN	push ENTER	- RS pickup = 0
O.	1110	OUT	IN	OUT	OUT	push ENTER	- RS operate with 2nd reclose
P.	1111					push ENTER	- Recloser in lockout ready to operate

The 4 multiplier was used to increase the reclose signal time limit in order to avoid going to lockout while operating the Instantaneous reclose.



## RECLOSER

The recloser is now ready for test. To check the program, push READ and observe the LCD as follows. It should be noted that, even though a pause limit is programmed in, the pause input will not operate because the pause control (see Figure RE-9) is in the 3 to 4 position. Remember that the time multiplier is set at 4!

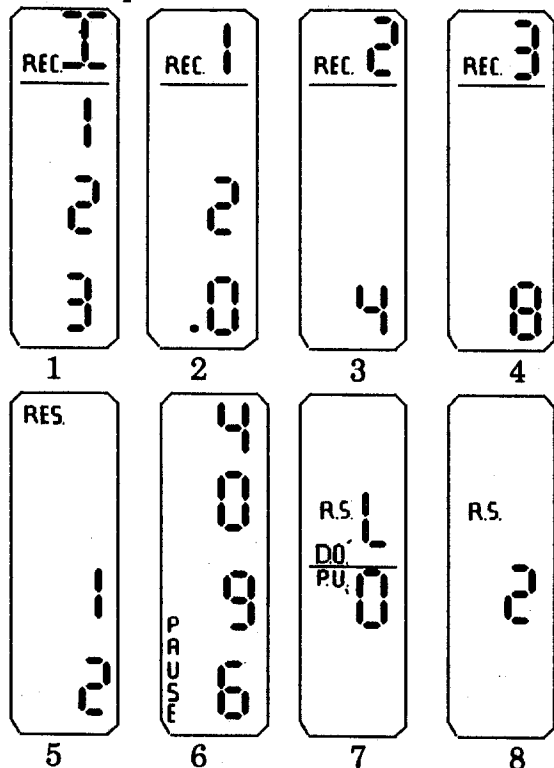

Before starting the functional testing, monitor the output contacts of interest.

Push the CLOSE button for 1 second and then release. The 52 relay of the test circuit will pick up, along with the IP "In Progress" relay of the recloser. RES. "Reset" of the LCD will come on and the LCD will count down the 12 second reset time. After the reset time, BI, LO, and IP relays will drop out and only RES. will appear on the LCD. The RLM131 is now in the reset condition.

Push the OPEN button for 1 second and then release. During the 1 second period, the following occurs:

1. The 52 relay of the test circuit drops out.
2. The BI, IP, and REC "Reclose" relays will pick up.

3. RES. of the LCD will go out and the reclose LED will come on.
4. B.I. of the LCD will come on and the LCD will start counting down the 3.6 second reclose-signal time limit. (During the 1 second time period, 3 will appear for .6 second and 2 for .4 second.)

As soon as the OPEN button is released, the following occurs:

1. The 52 relay of the test circuit picks up.
2. The REC relay will drop out.
3. RES. of the LCD will come on and the reclose LED will go out.
4. The LCD will start counting down the 12 second reset time.

Before the 12 second reset time is complete, push the OPEN button for 1 second and then release. As soon as the OPEN button is pushed, the RES. of the LCD will go out, REC.1 (1st reclose) of the LCD will come on, and the LCD will start counting down the 2 second 1st reclose in .5 second intervals. When the OPEN button is released, the LCD continues to count down the 2 second 1st reclose. After the 2 second 1st reclose time, the REC relay will pick up and the reclose LED will come on. The REC relay and the reclose LED will only be on until the 52 relay of the test circuit picks up and the recloser responds to the change of state of the 52 relay. Because the pickup time for 52 is short, the reclose LED will appear to have a single blink during reclose. Now that the 52 relay is picked up, REC.1 of the LCD has gone out and RES. of the LCD has come on. At this time the recloser is counting down the 12 second reset time.

Before the 12 second reset time is complete, push the OPEN button for 1 second and then release. The recloser will now do REC.2 (2nd reclose). The 2nd reclose is similar to the 1st, except the second reclose has a time delay of 4 seconds counted down in 1 second intervals and initiates the RS "Relay Spare" relay when the 2nd reclose of 52 takes place. R.S. of the LCD will come on to indicate that the RS relay has picked up. It should be noted that the 2nd reclose is the second timed reclose and the 3rd reclose of the reclose

cycle, due to Instantaneous reclose being called for. With 52 picked up, the recloser is in reset and is counting down the 12 second reset time.

Before the 12 second reset time is complete, push the OPEN button for 1 second and then release. The RLM131 will now do REC.3 (3rd reclose). The 3rd reclose is similar to the first, except the third reclose has a time delay of 8 seconds, counted down in 1 second intervals. At the end of the 8 seconds, the 52 test relay will pick up, and the recloser will start counting down the 12 second reset time.

Before the 12 second reset time is complete, push the OPEN button for 1 second and then release. When the recloser responds to the 52 relay of the test circuit,

it will proceed to lockout with the following results:

1. The IP and RS relays will drop out and the LO relay will pick up.
2. RES. and R.S. of the LCD will go out and L.O. of the LCD will come on.

The recloser is now back in lockout condition, where the test started.

This functional test exercises most, but not all, of the electronics in the RLM131 recloser system. In most cases it will indicate that the relay is completely functional. The 2 inputs not used in this test (DR and P), along with other settings, in most instances can be tested with the same basic test setup.

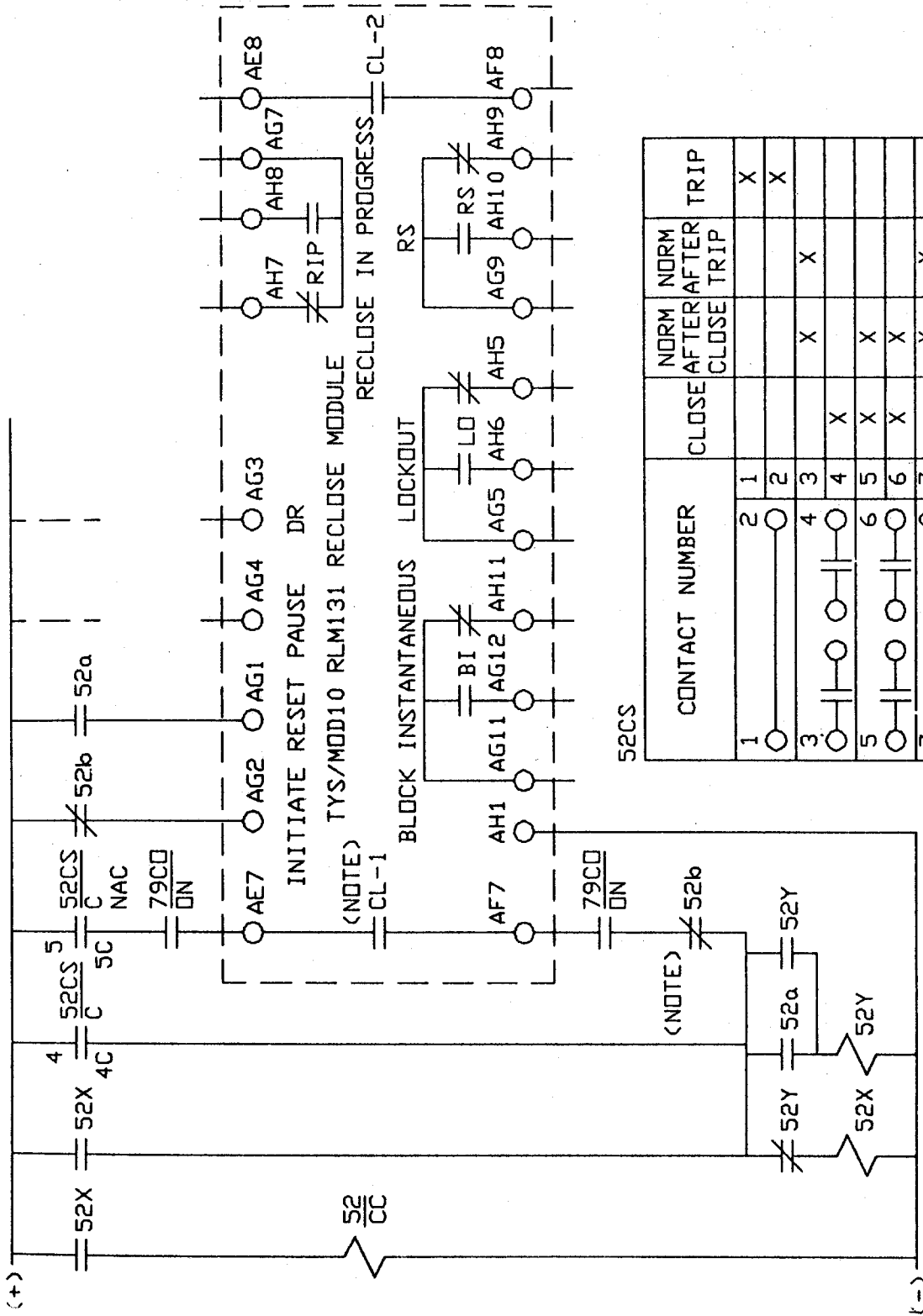

52CS

CONTACT NUMBER	CLOSE	NORM AFTER CLOSE	NORM AFTER TRIP
1			X
2			X
3		X	
4	X		
5	X	X	
6	X	X	
7		X	
8	X		

NOTE: 52b CONTACT REQUIRED ONLY IF REC CONTACT RATING IS EXCEEDED. (SEE RATINGS)

BREAKER CONTROL SWITCH MODEL 16SB1DD920STS2P WITH ESCUTCHEON 6402670 AND NAMEPLATE 78848-G

EXTERNAL CONNECTIONS TYS/MOD10 RLM131 RECLOSER MODULE

\* Figure RE-1 (0285A9671 [2]) External Connections, TYS/MOD10™ RLM131 Recloser Module

\* Revised since last issue



SETTING TABLE

	CODE			NUMBER					
RECLOSE	0	0	0	0	0	0	3RD 2ND 1ST INST	8 4 2 1	SUM
FIRST	0	0	0	1	1	0		.4 .2 .2 .1	
SECOND	0	0	1	0	1	1		80 40 20 10	SUM
THIRD	0	1	0	0	0	0		4 2 2 1	
RESET	0	1	1	1	1	1		80 40 20 10	SUM
TIME MULTIPLIER	1	0	0	1	0	1		4 2 1 .5	
PAUSE	1	0	1	1	1	1		1024 64 4 0	
DROP OUT	1	1	0	0	0	0		∞ 256 16 1	
PICK UP	1	1	0	1	0	1		L 24 12 6	
RS	1	1	1	0	0	0		4 2 1 0	
OPERATE	1	1	1	1	1	1		3RD 2ND 1ST INST	SELECT ONE

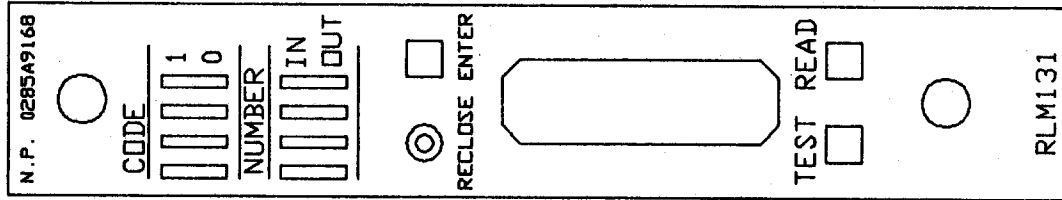

\* Figure RE-2 (0285A9670 [2]) RLM131 Recloser Front Panel and Setting Table

\* Revised since last issue



RECLOSER

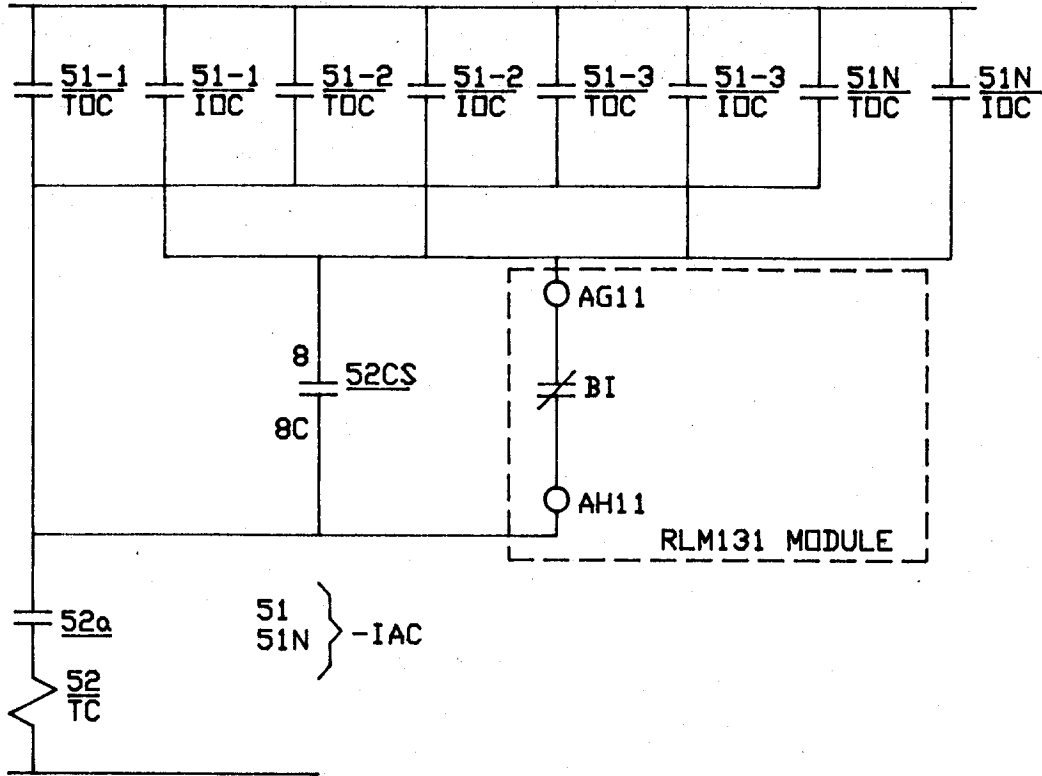

Figure RE-3 (0285A9672-1) Use of BI Contact to Block Instantaneous Trip Prior to First Reclosure

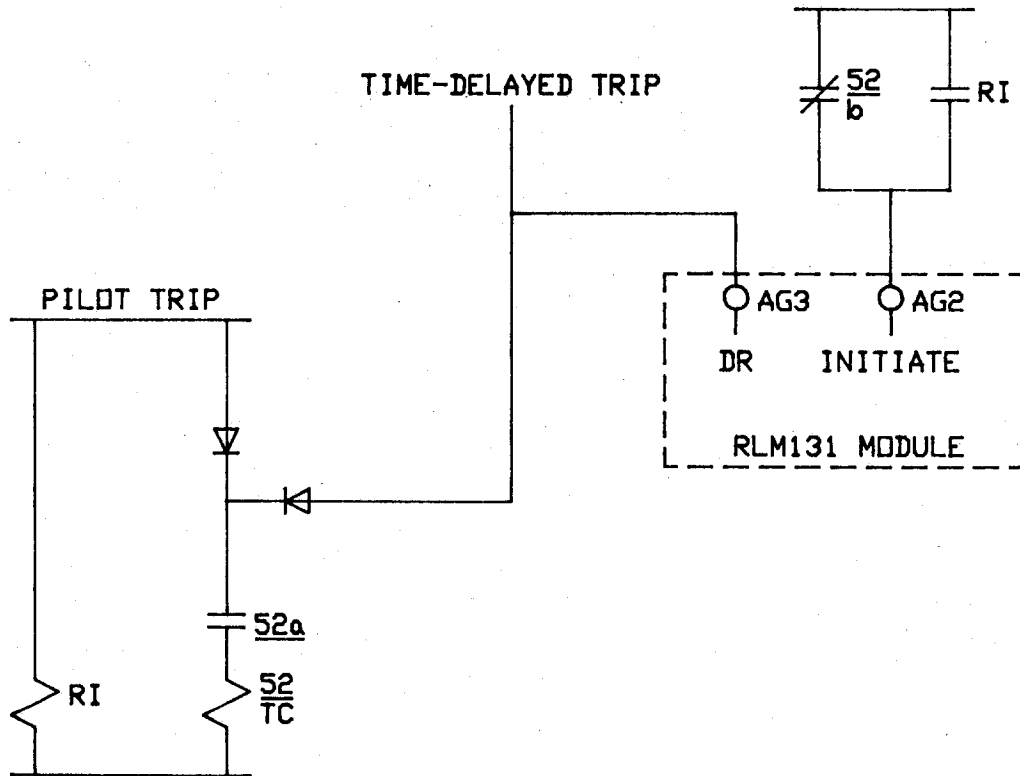
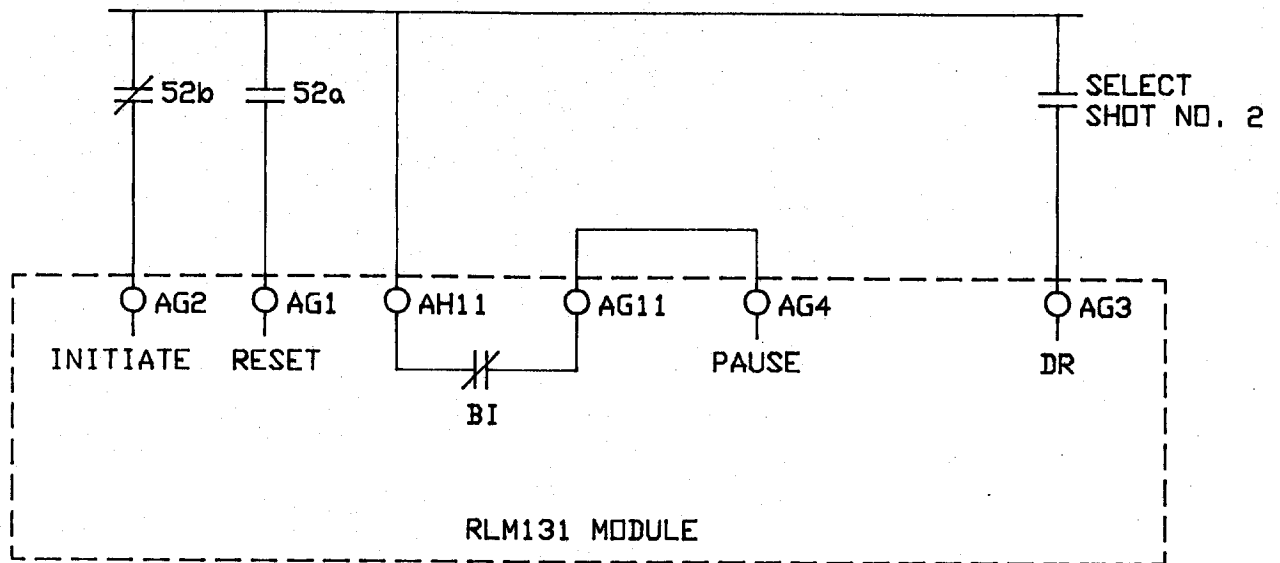

Figure RE-4 (0285A9673-1) RI (Reclose Initiate) and Delayed Reclose



SHOT NO.1: INSTANTANEDUS DR TIME DELAY  
 SHOT NO.2: TIME DELAY ONLY

Figure RE-5 (0285A9674-2) Connections for Two Separate Single-Shot Reclosures, Each With a Different Time Delay

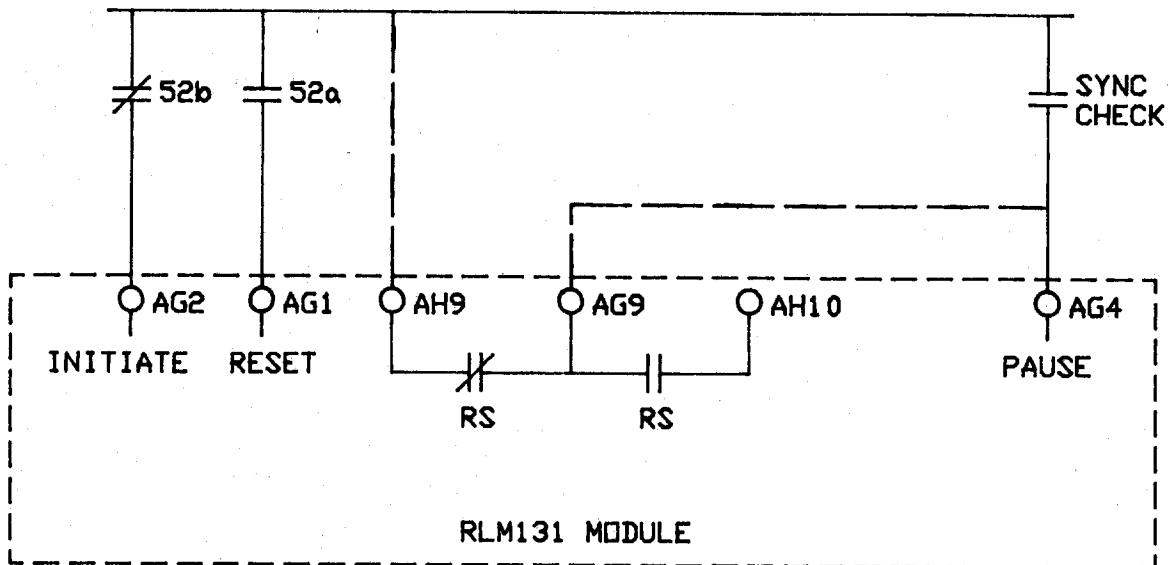
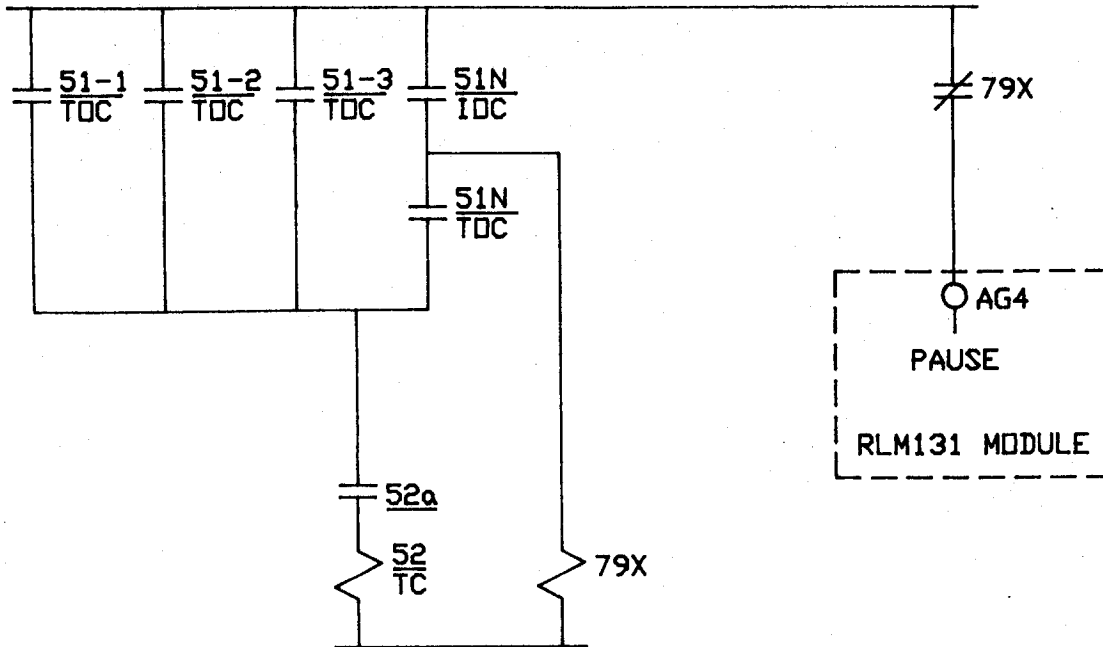

Figure RE-6 (0285A9675-1) Connections for Synchronism Check Supervision

RE

RECLOSER



TOC - TIME OVERCURRENT  
 IOC - INSTANTANEOUS OVERCURRENT

Figure RE-7 (0285A9676-1) Delay Reset for Ground Faults

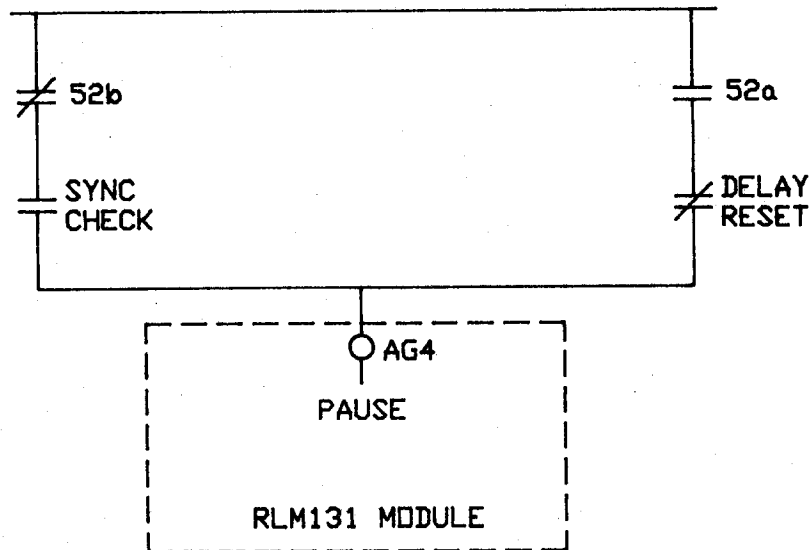
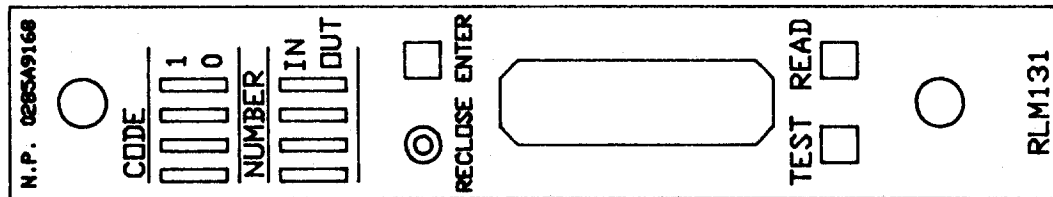
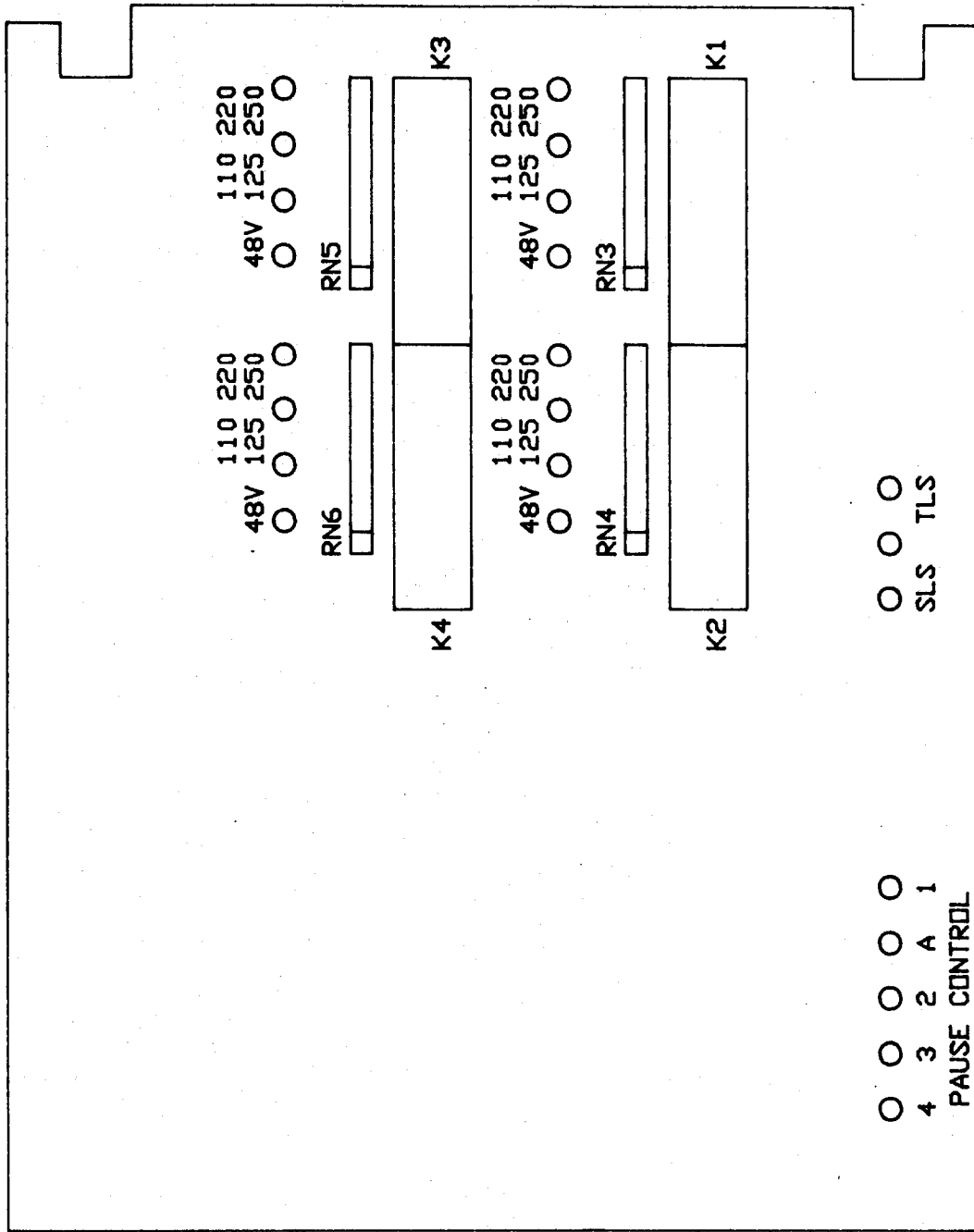

Figure RE-8 (0285A9677-1) Pause Function, Dual Use

RECLOSER  
CONTROL  
BOARD



RECLOSER CIRCUIT BOARD



SETTINGS

Figure RE-9 (0285A9678-1) Front Panel and Internal Links, RLM131 Module



RECLOSER

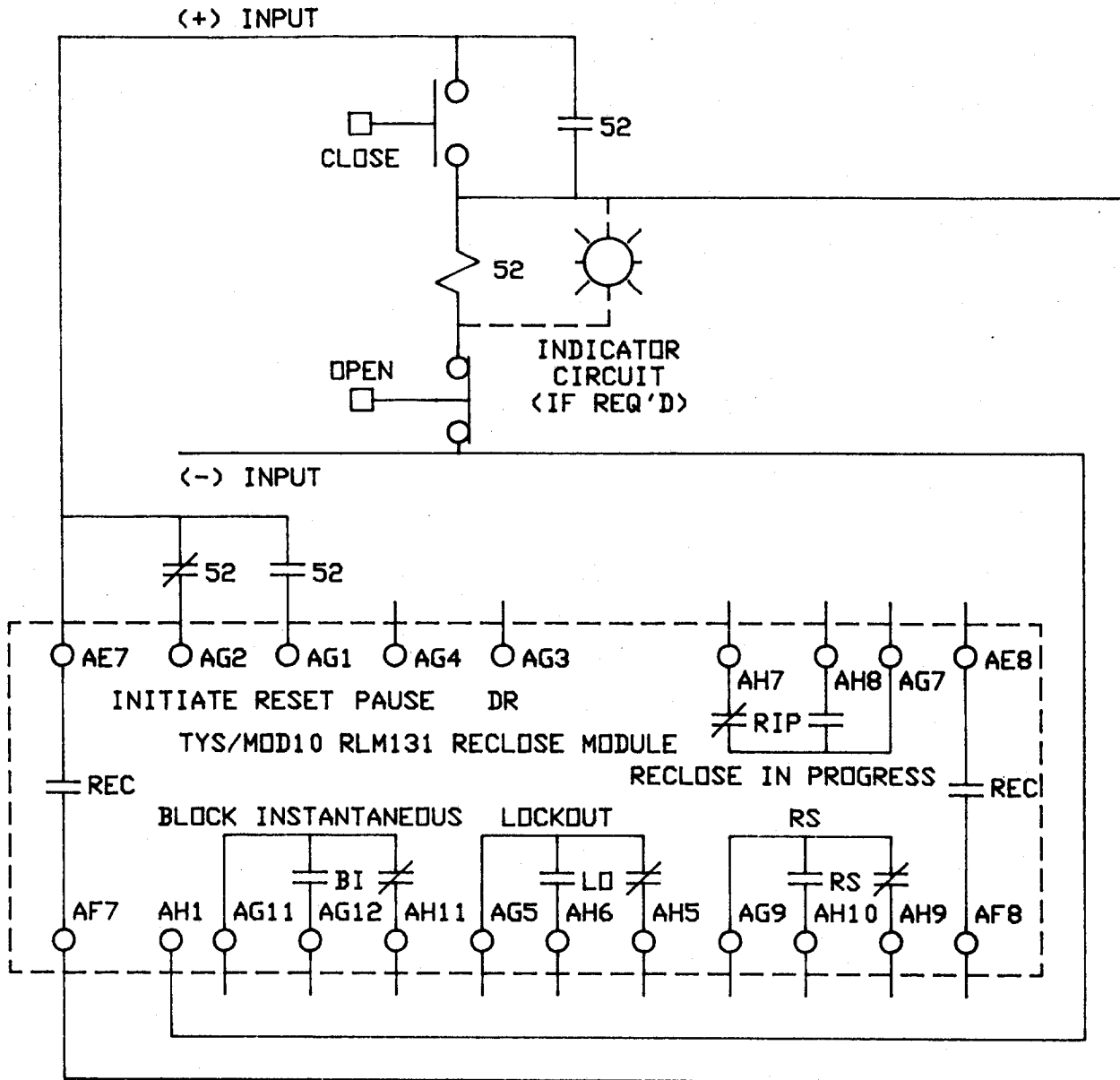

NOTE: THE SWITCHES ON THE ABOVE CIRCUIT ARE MOMENTARY.  
 THE 52 RELAY COIL SHOULD BE RATED FOR THE INPUT VOLTAGE.

Figure RE-10 (0285A9679-1) Functional Test Diagram.





---

***GE Power Management***

215 Anderson Avenue  
Markham, Ontario  
Canada L6E 1B3  
Tel: (905) 294-6222  
Fax: (905) 201-2098  
[www.GEindustrial.com/pm](http://www.GEindustrial.com/pm)