



INSTRUCTIONS AND RECOMMENDED PARTS FOR MAINTENANCE

GEK-39671F
Supersedes GEK-39671E

POWER/VAC* VACUUM CIRCUIT BREAKER WITH ML-17 MECHANISM

Types: □

- VB-4.16-250-1200A-58-0, -1, -2, -3
- ** VB-4.16-250-1200A-78-0, -1, -2, -3
- VB-4.16-250-2000A-58-0, -1, -2, -3
- ** VB-4.16-250-2000A-78-0, -1, -2, -3

- VB-4.16-350-1200A-78-0, -1, -2, -3
- VB-4.16-350-2000A-78-0, -1, -2, -3
- VB-4.16-350-3000A-78-0, -1, -2, -3

- VB-7.2-500-1200A-66-0, -1, -2, -3
- VB-7.2-500-1200A-78-0, -1, -2, -3
- VB-7.2-500-2000A-66-0, -1, -2, -3
- VB-7.2-500-2000A-78-0, -1, -2, -3

- VB-13.8-500-1200A-37-0, -1, -2, -3
- ** VB-13.8-500-1200A-58-0, -1, -2, -3
- VB-13.8-500-2000A-37-0, -1, -2, -3
- ** VB-13.8-500-2000A-58-0, -1, -2, -3

- VB-13.8-750-1200A-58-0, -1, -2, -3
- ** VB-13.8-750-1200A-77-0, -1, -2, -3
- VB-13.8-750-2000A-58-0, -1, -2, -3
- ** VB-13.8-750-2000A-77-0, -1, -2, -3

- VB-13.8-1000-1200A-77-0, -1, -2, -3
- VB-13.8-1000-2000A-77-0, -1, -2, -3
- VB-13.8-1000-3000A-77-0, -1, -2, -3

□ Vacuum Breaker — Nominal Voltage — Nominal MVA —
Continuous Current — Close and Latch Kiloamperes — Model Designator
(No number on breaker nameplate indicates -0 Model)

** Non-Standard High Close and Latch Ratings.

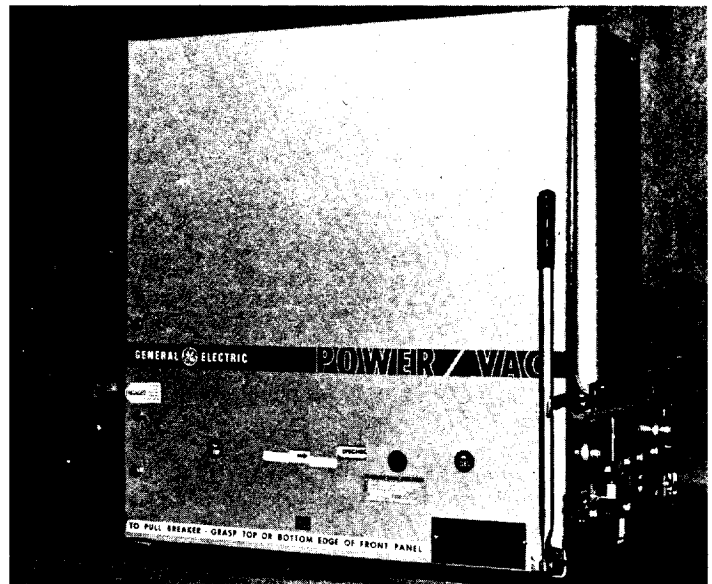

GENERAL  ELECTRIC

ILLUSTRATIONS

Figure No.		Page No.
1.	Power/ Vac* Breaker — Front View	7
2.	Front View of Power/ Vac* Breaker Without Front Cover	7
3.	Toggle Linkage Positions of ML-17 Mechanism — View from Rear	9
4.	Exploded Schematic — Rear View ML-17 Mechanism	
	a. -0, -1 Model Designations	10-11
	b. -2, -3 Model Designations	12-13
5.	Typical Wiring Diagram for ML-17 Mechanism	14
6.	Rear View of Power/ Vac* Breaker Showing Rating Interference Plate	15
7.	Rating Interference Plate 1200/2000A Breaker	15
8.	Power/ Vac* Breaker — Right Side View	15
9.	Power/ Vac* Breaker — Left Side View	16
10.	Closing Spring Gag Interlock	16
11.	Slow Close Pin on Flywheel	18
12.	Primary Contact Gap and Erosion Indication	19
13.	Wipe Gauge	20
14.	Control Switches	21

CONTENTS

1.	Introduction	5
1.1	Scope	5
1.2	Safety	5
1.2.1	General	5
1.2.2	Specific	5
2.	Receiving, Handling and Storage	6
2.1	Receiving	6
2.2	Handling	6
2.3	Storage	6
3.	Description and Principles of Operation	6
3.1	General	6
3.2	Close Spring Charging	7
3.3	Closing Operation	8
3.4	Opening Operation	8
3.5	Trip Free Operation	8
3.6	Control Circuit	8
3.7	Interlocks	8
3.7.1	Rating Interference Plate	8
3.7.2	Closing Spring Discharge Interlock	15
3.7.3	Negative Trip Interlock	16
3.7.4	Positive Interlock	16
3.7.5	Closing Spring Gag Interlock	16
4.	Preinstallation Checkout	17
4.1	General	17
4.2	Safety Precautions	17
4.3	Shipping Position	17
4.4	Mechanical Operation	17
4.5	Electrical Checks	17
5.	Mechanical Checks and Adjustments	18
5.1	General	18
5.2	Slow Closing Operation	18
5.3	Pull Rod Adjustment	18
5.4	Trip Latch Clearance	19
5.5	Overtravel Stop Bolts	19
5.6	Wipe and Gap Adjustments	19
5.6.1	General	19
5.6.2	Checking	20
5.6.3	Adjustment	20
5.7	Primary Contact Erosion Indication	21
5.8	Control Coil Plunger Travel	21
5.8.1	Trip Coil	21
5.8.2	Close Coil	21
5.9	Control Switches	21

6.	Electrical Checks	22
6.1	Control Power	22
6.2	Timing	22
6.3	Megger	22
6.4	High-Potential Test	22
6.4.1	Primary Circuit	22
6.4.2	Secondary Circuit	22
6.5	Vacuum Interrupter Integrity Test	22
6.6	Primary Circuit Resistance	22
7.	Maintenance	23
7.1	General	23
7.2	Service Conditions	23
7.3	Fault Interruptions	23
7.4	Recommended Maintenance	23
7.5	Lubrication	24
	APPENDIX A	
	Recommended Spare Parts and repair Procedures	25
	APPENDIX B	
	Undervoltage Trip Device	47

POWER/VAC* VACUUM CIRCUIT BREAKER WITH ML-17 MECHANISM

TYPES VB-4.16-250,-350
VB-7.2-500
VB-13.8-500, -750, -1000

1. INTRODUCTION

1.1 SCOPE

This manual provides information needed by the user to properly check out, install and maintain the Power/Vac* breaker.

Appendix A provides a list of recommended spare parts for the Power/Vac* breaker and instructions for installation and repair.

Appendix B provides instructions for check out and maintenance of breakers equipped with a Direct Acting Undervoltage Trip Device.

The Power/Vac* vacuum circuit breaker is a horizontal drawout, removable and interchangeable interrupting element for use in metalclad switchgear to provide protection and control of electrical apparatus and power systems. To the extent required applicable ANSI, IEEE and NEMA Standards are met. No such assurances are given with respect to local codes and ordinances as they vary greatly.

The Power/Vac* circuit breakers are available in continuous current ratings of 1200, 2000 and 3000 amperes in accordance with industry standards. Non-standard close and latch ratings, as shown on the front cover of this manual, are available. Combination 1200/2000 ampere breakers are also available. Refer to the breaker nameplate for complete rating information.

1.2 SAFETY

Each user has the responsibility to instruct all personnel associated with this equipment on all safety precautions which must be observed. The following are recommendations to be considered in a user's safety program. These recommendations are not intended to supplant the user's responsibility for devising a complete safety program and shall not be considered as such. They are rather suggestions to cover the more important aspects of personnel safety related to circuit breakers. General Electric neither condones nor assumes any responsibility for user practices which deviate from these recommendations.

These instructions do not purport to cover all details or variations in equipment nor to provide for every possible contingency to be met in connection with installation, operation or maintenance. Should further information be desired or should particular problems arise which are not covered sufficiently for the purchaser's purposes, the matter should be referred to the General Electric Company.

1.2.1 GENERAL

1. All personnel associated with installation, operation, and maintenance of power circuit breakers should be thoroughly instructed and supervised regarding power equipment in general and, also, the particular model of equipment with which they are working. Instruction books should be closely studied and followed.

2. Maintenance programs must be well planned and carried out consistent with both customer experience and manufacturer's recommendations. Good maintenance is essential to breaker reliability and safety.

Local environment and breaker application must be considered in such programs, including such variables as ambient temperatures, actual continuous current, number of operations, type of interrupting duty, and any unusual local condition such as corrosive atmosphere or vermin problems.

1.2.2 SPECIFIC

1. DO NOT WORK ON AN ENERGIZED BREAKER. IF WORK HAS TO BE PERFORMED ON THE BREAKER, TAKE IT OUT OF SERVICE AND REMOVE IT FROM THE METALCLAD.

2. DO NOT WORK ON ANY PART OF THE BREAKER WITH THE TEST COUPLER ENGAGED.

3. All spring-charged mechanisms related to a breaker must be serviced only by skilled and knowledgeable personnel capable of gagging or releasing each spring load in a controlled manner. PARTICULAR CARE MUST BE EXERCISED TO KEEP PERSONNEL CLEAR OF MECHANISMS WHICH ARE TO BE OPERATED OR RELEASED. Information on construction of such mechanisms is provided in this instruction book.

4. Operational tests and checks should be made on a breaker after maintenance, before it is returned to service, to ensure that it is capable of operating properly. The extent of such tests and checks should be consistent with the level of maintenance performed.

5. If maintenance on the Power/Vac* breaker is being performed to an extended schedule such as on a 5 year or 10 year basis, it is recommended that the vacuum interrupter integrity test of paragraph 6.5 be performed each time the breaker is removed from the metalclad switchgear for reasons other than scheduled breaker maintenance if it has been more than one year since the last vacuum interrupter integrity test.

6. Interlocks are provided for the safety of the operator and correct operation of the breaker. If an interlock does

not function as described DO NOT MAKE ANY ADJUSTMENT OR FORCE THE DEVICE INTO POSITION; CONTACT THE NEAREST GENERAL ELECTRIC COMPANY INSTALLATION AND SERVICE OFFICE FOR INSTRUCTIONS.

7. For breakers equipped with a Direct Acting Under-voltage Trip Device REFER TO APPENDIX "B" PRIOR TO PERFORMING Initial Checkout, Maintenance, or Repair.

2. RECEIVING, HANDLING AND STORAGE

2.1 RECEIVING

Each breaker is carefully inspected before shipment. Immediately upon receipt of the circuit breaker, an examination should be made for any damage sustained in transit. If injury or rough handling is evident, a damage claim should be filed immediately with the transportation company and the nearest General Electric Sales Office should be notified.

It is expected that due care will be exercised during the unpacking and installation of the breaker so that no damage will occur from careless or rough handling, or from exposure to moisture or dirt.

2.2 HANDLING

When lifting the breaker, use of the specially designed lift truck is recommended. It is necessary to use the truck when placing a breaker into or removing it from the metalclad switchgear. If it is necessary to lift the breaker with a hoist use four ½ inch diameter hooks rated at least 500 pounds each. Lifting locations are provided in the side frame members. Use a spreader wider than the breaker to prevent slings from contacting the interrupter supports.

A front swivel wheel and two rear wheels are provided for ease of movement on flat, level floors.

2.3 STORAGE

It is recommended that the breaker be put immediately in its permanent location. If this is not possible, the following precautions must be taken to assure the proper storage of the breaker:

1. The breaker should be protected against condensation, preferably by storing it in a warm dry room of moderate temperature such as 40° - 100° F. Circuit breakers for outdoor metalclad switchgear should be stored in the equipment only when power is available and the heaters are in operation to prevent condensation.

2. The breaker should be stored in a clean location, free from corrosive gases or fumes; particular care, for example, should be taken to protect the equipment from moisture and cement dust, as this combination is present at construction sites and has a very corrosive effect on many parts.

3. Rollers, latches, etc., of the operating mechanism should be coated with 0282A2048P009 grease to prevent rusting.

If the breaker is stored for any length of time, it should be inspected periodically to see that rusting has not started and to ensure good mechanical condition. Should the breaker be stored under unfavorable atmospheric conditions, it should be cleaned and dried out before being placed in service.

3. DESCRIPTION AND PRINCIPLES OF OPERATION

3.1 GENERAL

The Power/Vac* vacuum circuit breaker uses sealed vacuum power interrupters to establish and interrupt a primary circuit. Primary connections to the associated metalclad switchgear are made by horizontal bars and disconnect fingers, electrically and mechanically connected to the vacuum interrupters. Molded interrupter supports, one per phase on a three-phase circuit breaker, provide mount-

ings for the primary bars, interrupters, current transfer fingers, and heat dissipation fins (where used). The operating mechanism provides vertical motion at each phase location in order to move the lower contact of the vacuum interrupters from an open position to a spring-loaded closed position and then back to the open position on command.

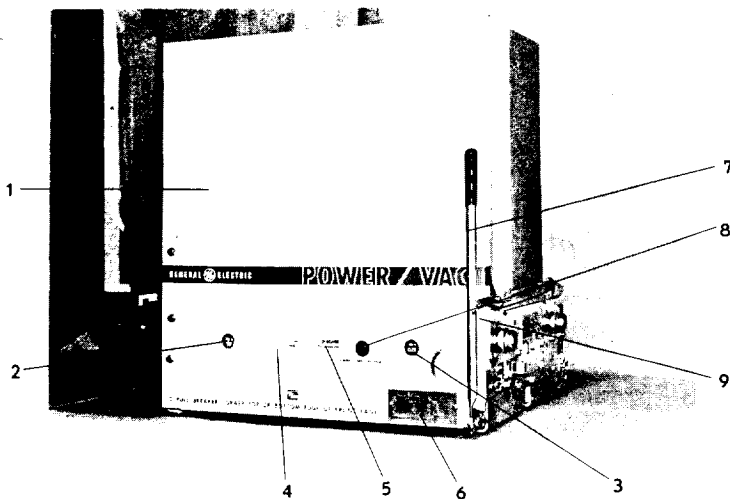

Fig. 1 — Power/Vac* Breaker — Front View

- 1 — Front cover
- 2 — Manual trip button
- 3 — Manual close button
- 4 — OPEN/CLOSE indicator
- 5 — CHARGE/DISCHARGE indicator
- 6 — Nameplate
- 7 — Secondary Disconnect Handle
- 8 — Manual Wind Shaft
- 9 — Rackout Arm

The ML-17 mechanism is of the stored-energy type and uses a gearmotor to charge a closing spring. During a closing operation, the energy stored in the closing spring is used to close the vacuum interrupter contacts, compress the wipe springs which load the contacts, charge the opening spring, and overcome bearing and other friction forces. The energy then stored in the wipe springs and opening spring will open the contacts during an opening operation.

Closing and opening operations are controlled electrically by the metalclad switchgear or remote relaying. Mechanical control is provided by manual close and trip buttons on the circuit breaker. The closing spring may be manually charged, and a method for slow-closing the primary contacts is available. The mechanism will operate at the a-c or d-c voltage indicated on the circuit breaker nameplate.

Mechanical and electrical interlocks are provided and are described in PARAGRAPH 3.7, INTERLOCKS.

3.2 CLOSE SPRING CHARGING

Figure 4 shows the mechanism expanded schematically with the primary contacts open and the closing spring nearly charged. When the closing spring is discharged, the AA flywheel eccentric will be about 180 degrees from where it is shown with respect to center pivot CC. The transfer crank (14) will be rotated counterclockwise, the slotted link (17)

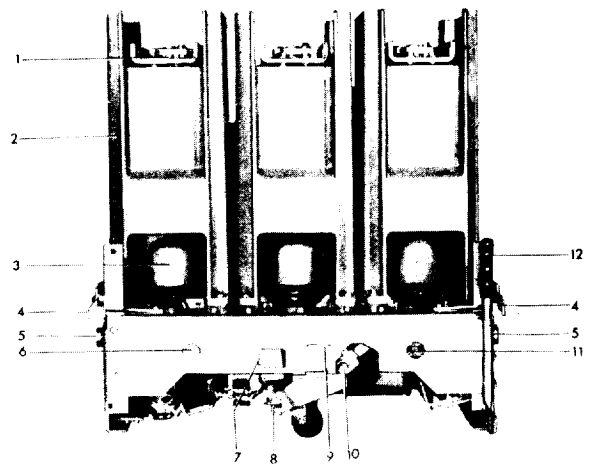

Fig. 2 Front View of Power/Vac* Breaker Without Cover

- 1 — Upper Interrupter Connection
- 2 — Interrupter Support
- 3 — Operating Rod
- 4 — Rackout Arm
- 5 — Rollers for Track
- 6 — Manual Trip Button
- 7 — Open-Close Indicator
- 8 — Counter
- 9 — Spring Charge Indicator
- 10 — Manual Wind Shaft
- 11 — Manual Close Button
- 12 — Handle to Connect Secondary Disconnects in Test Position

will be holding the close toggle (20, 21) against the frame through link (19), and the trip latch (18) will be held out of engagement clockwise by the trip toggle roller (52). The toggle linkage will appear as shown in Fig. 3(d). When the closing spring is discharged, switch operator (44), operates the motor limit switch (43). If the close-latch-checking switch (5) is made and power is available, the gearmotor (45) will drive the wind hub (11) counterclockwise. Slow-close pawl (10) will be held out of possible engagement with the wind hub notch by the action of the slow-close pin (48).

After some rotation of the wind hub (11) at no load, its notch engages the wind pawl (9) and rotates the flywheel counterclockwise, compressing the close spring assembly (6), and rotating the transfer crank (BB) shaft clockwise by pushing on rod (13). As the line of action of the close spring shifts over-center on the flywheel and attempts to discharge, the close roller (3) is blocked by the close latch (4) and held until a closing operation is required. Additionally, as the close spring goes over-center, the switch operator (44) is spring biased into a notch on the front flywheel (2). Arm (40) moves clockwise which, through the action of the rod (41) causes a flag (42) to indicate "CHARGE". A cam (12) engages the wind pawl (9), moving it from contact with the hub (11) notch, thereby allowing the gearmotor to coast to a stop when power is removed by limit switch (43).

As the close spring is compressed, the slotted link (17) rises, and the close toggle (20, 21) forms a more acute angle

until the closing spring goes over-center and the trip latch (18), is spring biased into place under the trip roller. When the trip latch is in place, the latch-checking switch (47) closes.

With the close spring charged and the breaker open the toggle linkage is as shown in Fig. 3(a).

If control power is lost, or manual operation desired, the close spring may be manually charged by using a $\frac{3}{8}$ inch hex socket ratchet-type wrench to rotate the manual charging wind shaft, (8) Fig. 1, in the direction indicated by the arrow until the yellow indicator shows "CHARGED".

3.3 CLOSING OPERATION (REFER TO FIG. 4)

By either energizing the close solenoid or depressing the manual close button, the close latch (4) is rotated counterclockwise and releases the close roller (3) permitting the flywheel (1, 2) to rotate counterclockwise by the force of the close spring. This action, transmitted to the slotted link (17) by means of the pull rod (13), transfer crank (14, 16), pulls the close toggle (20, 21) through the center against link (19) which is tied to the frame. This action rotates the output crank (22) counterclockwise. The Pole 1 bellcranks (23), on the same shaft as the output crank, also rotate counterclockwise, and by means of the horizontal connecting bar (28), rotate Pole 2 and 3 bellcranks. This rotation compresses the opening spring (29), closes the vacuum interrupters connected with each operating rod (25), and compresses the wipe spring (26) on each pole when the trunnion (24) continues moving after the operating rod (25) stops. Rotation of an arm (34) coupled to the output shaft (DD) changes the auxiliary switch (37) position, and the position flag (38) indicates "CLOSED". The lever (44) is moved out of the notch in the flywheel (2) and, with the close latch (4) in position to catch the close roller, the limit switch (43) energizes the gearmotor as described under CLOSE SPRING CHARGING. With the breaker closed, closing spring discharged, the toggle linkage appears as shown in Fig. 3(b). With the circuit breaker in the closed position, the links (17) can move up past the close toggle without disturbing it as they are slotted to accommodate a close spring charging in the breaker-closed position. With the close spring charged, breaker closed, the toggle linkage appears as shown in Fig. 3(c).

3.4 OPENING OPERATION (REFER TO FIG. 4)

By either energizing the trip solenoid or depressing the manual trip button, the trip latch (18) is rotated clockwise permitting the trip toggle (19, 20) to collapse and the vacuum interrupter contacts to open under the force of the wipe springs (26) and opening spring (29). At the end of the opening stroke, a stop block (30) on the bottom of the trunnion (24) strikes set screws in the horizontal connecting bar (28) which limits the over-travel. At the same time an opening stop is provided by a plate and buffer assembly (50). An opening dashpot (31) controls opening velocity and prevents excessive rebound of the interrupter contacts. Rotation of the output shaft (DD) from a closed to an open position operates the auxiliary switch (37) as described under CLOSING OPERATION and interrupts the trip coil circuit. If the closing spring is charged, the close toggle (20, 21) can raise

to the top of the slotted link (17), thereby permitting the trip toggle to reset and the trip latch to fall in place under its roller preparatory to a closing operation. If the closing spring is not charged, the trip latch is held rotated clockwise until the close spring is compressed as described in CLOSE SPRING CHARGING. Electrically initiated closing is blocked by the latch checking switch (47) when the trip latch is not reset.

3.5 TRIP-FREE OPERATION (REFER TO FIG. 4)

The linkage (19, 20, 21) is mechanically trip free in any location on the closing stroke. This means that energization of the trip coil while closing after the auxiliary switch contacts change position will rotate the trip latch (18) clockwise and permit the circuit breaker to open. The linkage will reset as in a normal open operation, the flywheel will complete its rotation, and the closing spring will recharge as described under SPRING CHARGING.

3.6 CONTROL CIRCUIT

A typical Power/Vac* circuit breaker ML-17 mechanism wiring diagram is shown in Fig. 5. Check the wiring diagram supplied with the actual circuit breaker for its wiring.

The close spring-charging-motor circuit is established through the 52 CL/MS (close latch monitor switch) switch if the close latch is reset and the 52 SM/LS (spring motor limit switch) if the closing spring is discharged. When the closing spring is charged, the 52 SM/LS interrupts the circuit.

The close circuit is established through two normally closed relay (anti pump) contacts, 52Y, and the latch-checking switch 52/LCS, if the trip latch is reset. An auxiliary switch "b" contact is also in series with the close coil. The "b" contact closes when the breaker is open and opens when the breaker is closed. During a close operation, flywheel rotation closes the 52 SM/LS contact, picking up the 52Y relay coil thereby opening the normally closed contacts to open the close coil circuit and seal the close signal in through the 52Y relay normally open contact. The sealing prevents reclosing on a sustained close command as the close signal must be removed to drop out the 52Y relay, and reestablish the close circuit, thereby providing an anti-pump feature.

Circuit breaker mounted auxiliary switch contacts not used in the control circuit are brought out for control and indication functions. The metalclad equipment may provide a breaker operated stationary auxiliary switch for additional contacts (3, 6 or 10 stages are available).

3.7 INTERLOCKS

Each Power/Vac* vacuum circuit breaker is provided with the following interlocks:

3.7.1 RATING INTERFERENCE PLATE

The rating interference plate, (Fig. 6) permits only a breaker of the matching continuous current, voltage and interrupting MVA rating to be inserted into a metalclad breaker compartment.

The 1200/2000 Ampere breaker can be used in either a 1200 or a 2000 ampere compartment. The rating interference plate must be adjusted to match the current rating of the compartment. This is done by positioning the outer

interference plate so that the edge lines up with the desired current indicated on the label attached to the breaker just above the rating interference plate. Refer to Fig. 7.

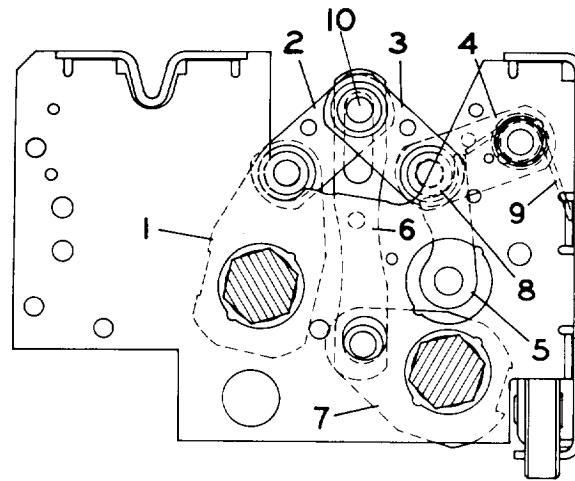

(a) Breaker Open-
Close Spring Charged

(b) Breaker Closed-
Close Spring Discharged

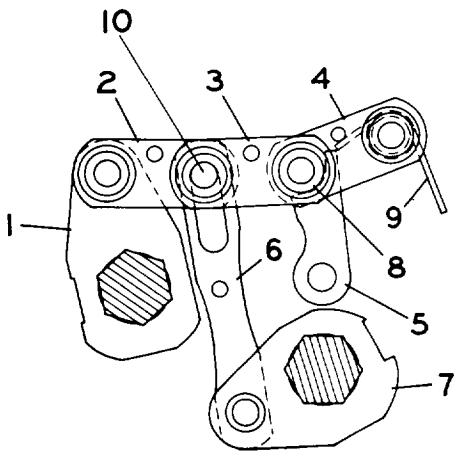

(c) Breaker Closed-
Close Spring Charged

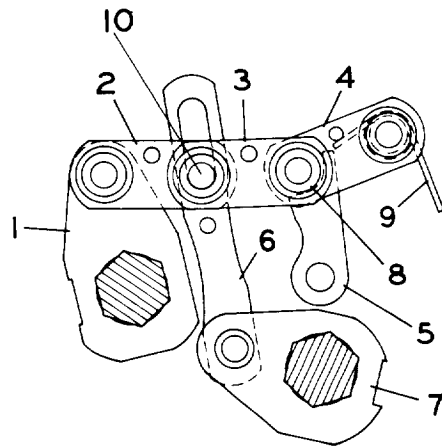

(d) Breaker Open-
Close Spring Discharged

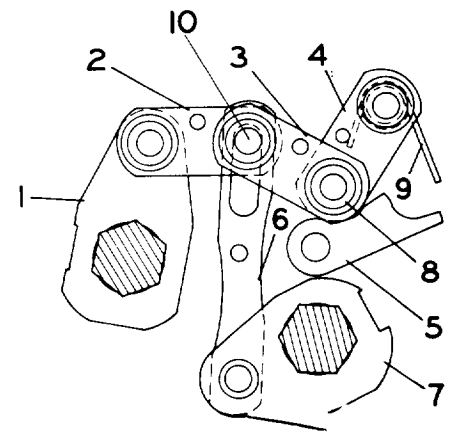
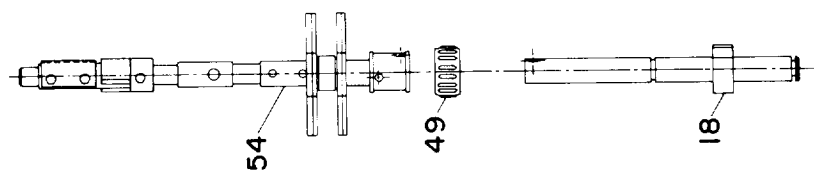
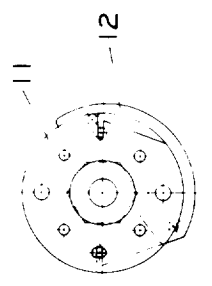
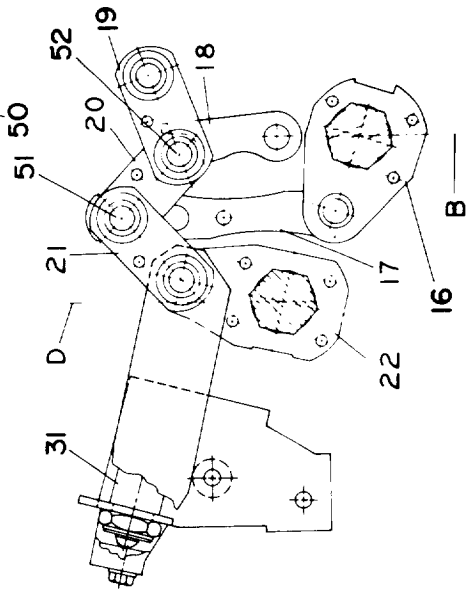
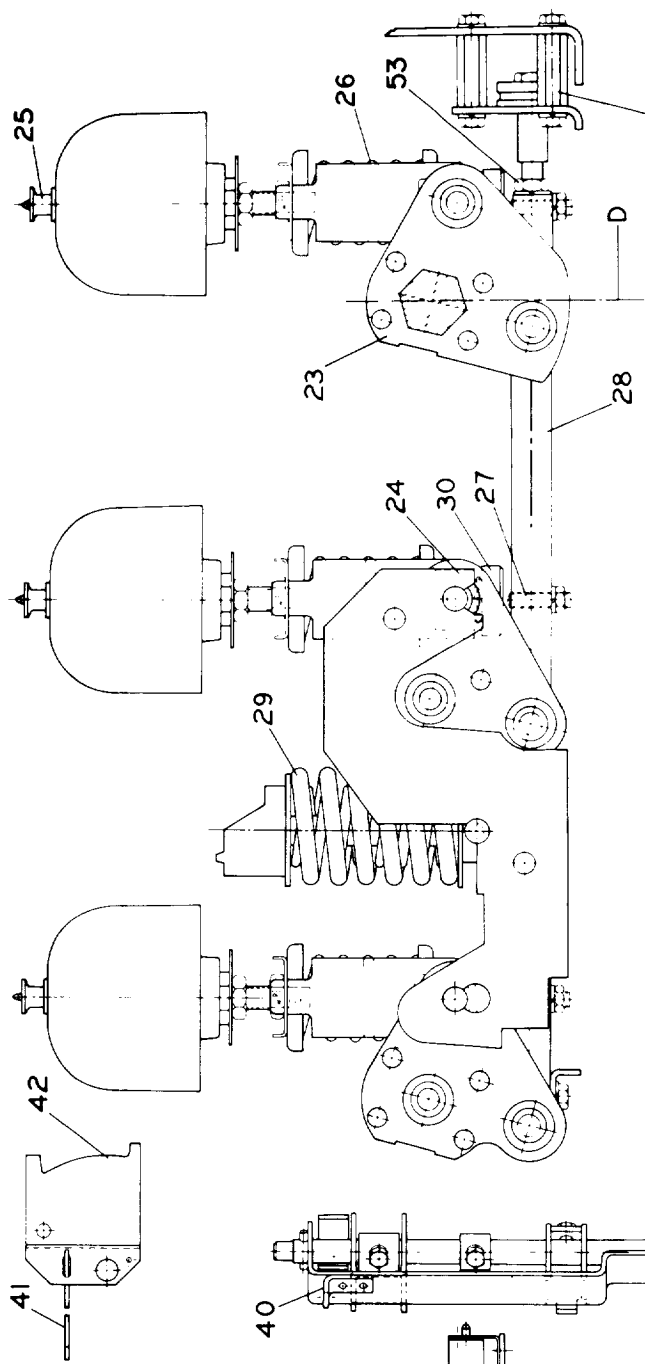
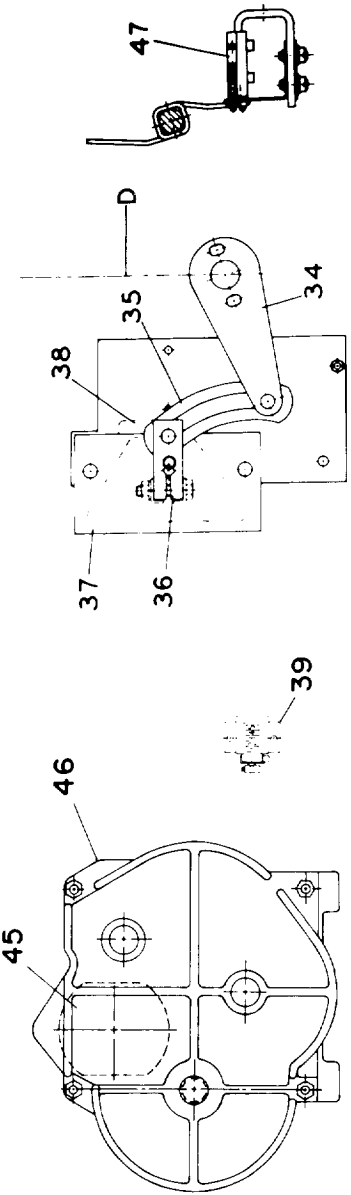

Fig. 3 Toggle Linkage Positions of ML 17 Mechanism
View From Rear

- 1 — Output Crank
- 2 — Link-Output Crank to Close Toggle
- 3 — Link-Close Toggle to Trip Toggle
- 4 — Link Trip Toggle to Frame
- 5 — Trip Latch

- 6 — Slotted Link
- 7 — Transfer Crank
- 8 — Trip Roller
- 9 — Linkage Return Spring
- 10 — Toggle Pin



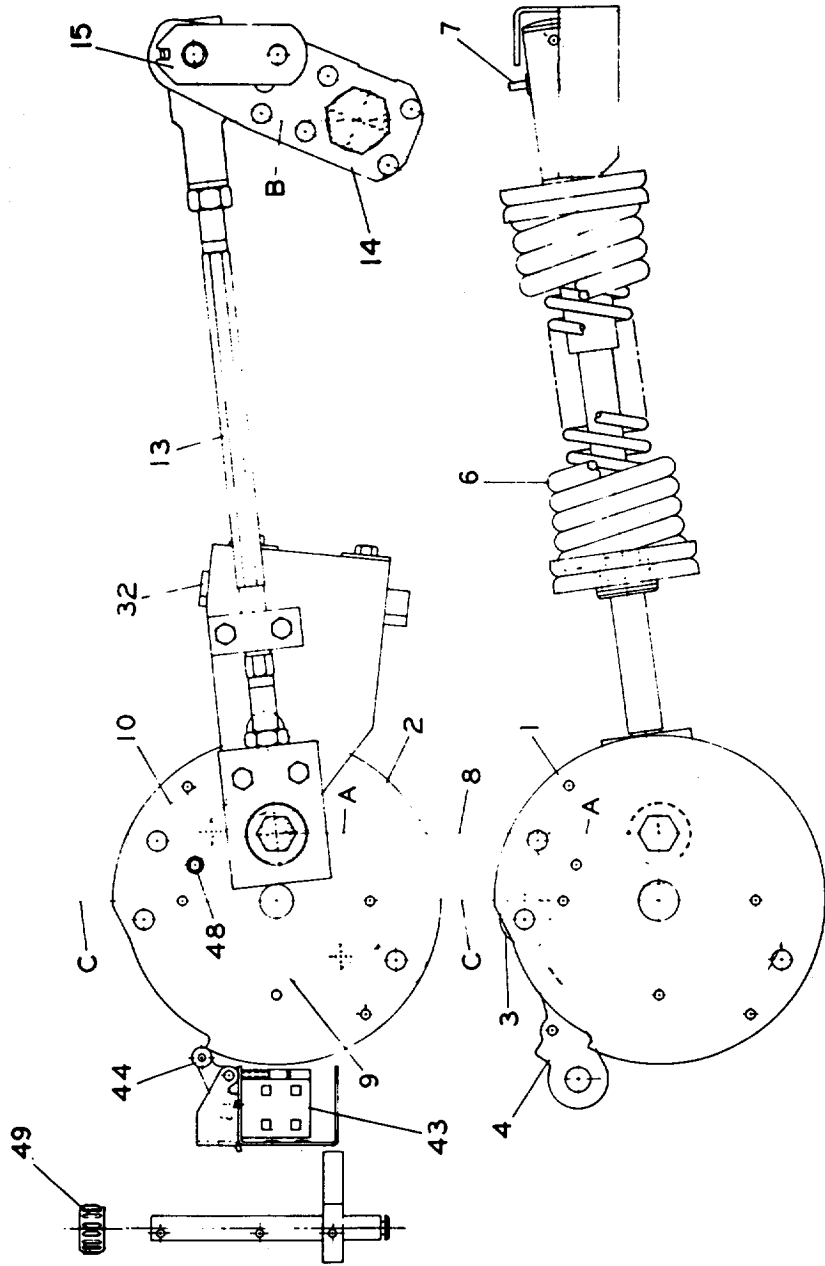
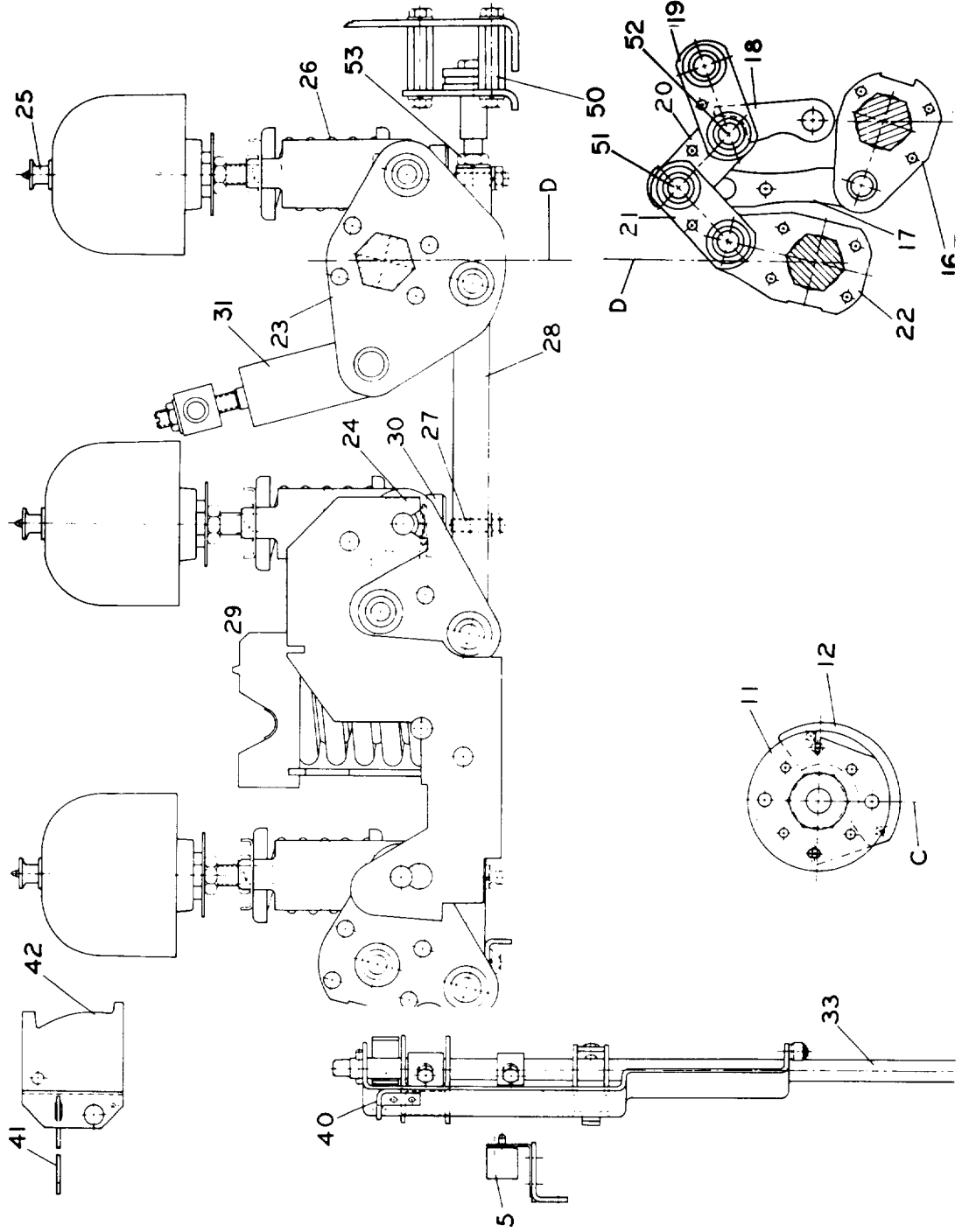
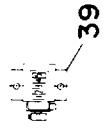
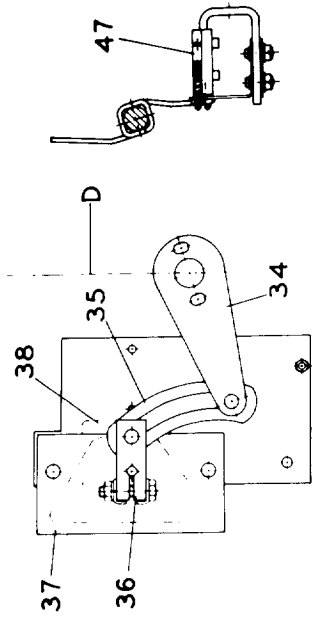
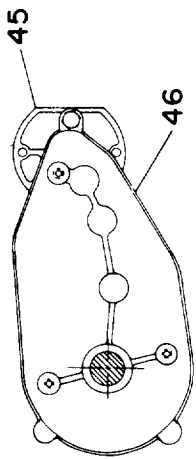

Fig. 4a Exploded Schematic — Rear View ML-17 Mechanism
For Model Designators -0 and -1

- AA Eccentric shaft connecting flywheel halves
- BB Hex shaft connecting Transfer cranks
- CC Flywheel rotation axis
- DD Hex shaft connecting Output cranks
- 1 Rear Flywheel Section
- 2 Front Flywheel Section
- 3 Close Roller
- 4 Close Latch
- 5 Close Latch Monitor Switch
- 6 Closing Spring Assembly
- 7 Blocking Pin in Closing Spring Assembly
- 8 Hex Shaft with Connection Blocks on Flywheel
- 9 Wind Pawl
- 10 Slow Close Pawl
- 11 Wind Hub
- 12 Pawl Disengagement Cam Surface — on Frame
- 13 Pull Rod
- 14 Adjustable Throw Transfer Crank
- 15 Adjustment Link (Factory Adjustment Only)
- 16 Short Transfer Crank
- 17 Slotted Link
- 18 Trip Latch
- 19 Link — Trip Toggle to Frame
- 20 Link from Close Toggle to Trip Toggle
- 21 Link from Output Crank to Close Toggle
- 22 Output Crank
- 23 Pole 1 Bell Cranks
- 24 Wipe Spring Trunnion Block
- 25 Interrupter Operating Rod Connection
- 26 Wipe Spring
- 27 Overtravel Stop Adjustment — on Each Pole
- 28 Horizontal Connecting Bar
- 29 Opening Spring Assembly
- 30 Opening Stop Block
- 31 Dashpot
- 32 Brake
- 33 Closing Latch Shaft
- 34 Auxiliary Switch Drive Arm
- 35 Idler Link
- 36 Switch Drive Arm
- 37 Auxiliary Switch — SB-12 — Four Stage
- 38 Position Indicator Flag
- 39 Operation Counter
- 40 Spring Charge Indicator Arm
- 41 Rod
- 42 Spring Charge-Discharge Indicator Flag
- 43 Spring Motor Limit Switch
- 44 Gear Motor Limit Switch Operator
- 45 Gearmotor
- 46 Gearmotor Housing
- 47 Trip Latch Checking Switch
- 48 Slow Close Pin
- 49 Retaining Clamp
- 50 Opening Stop
- 51 Toggle Pin
- 52 Trip Roller
- 53 Horizontal Bar Stop Locking Nut
- 54 Trip Shaft



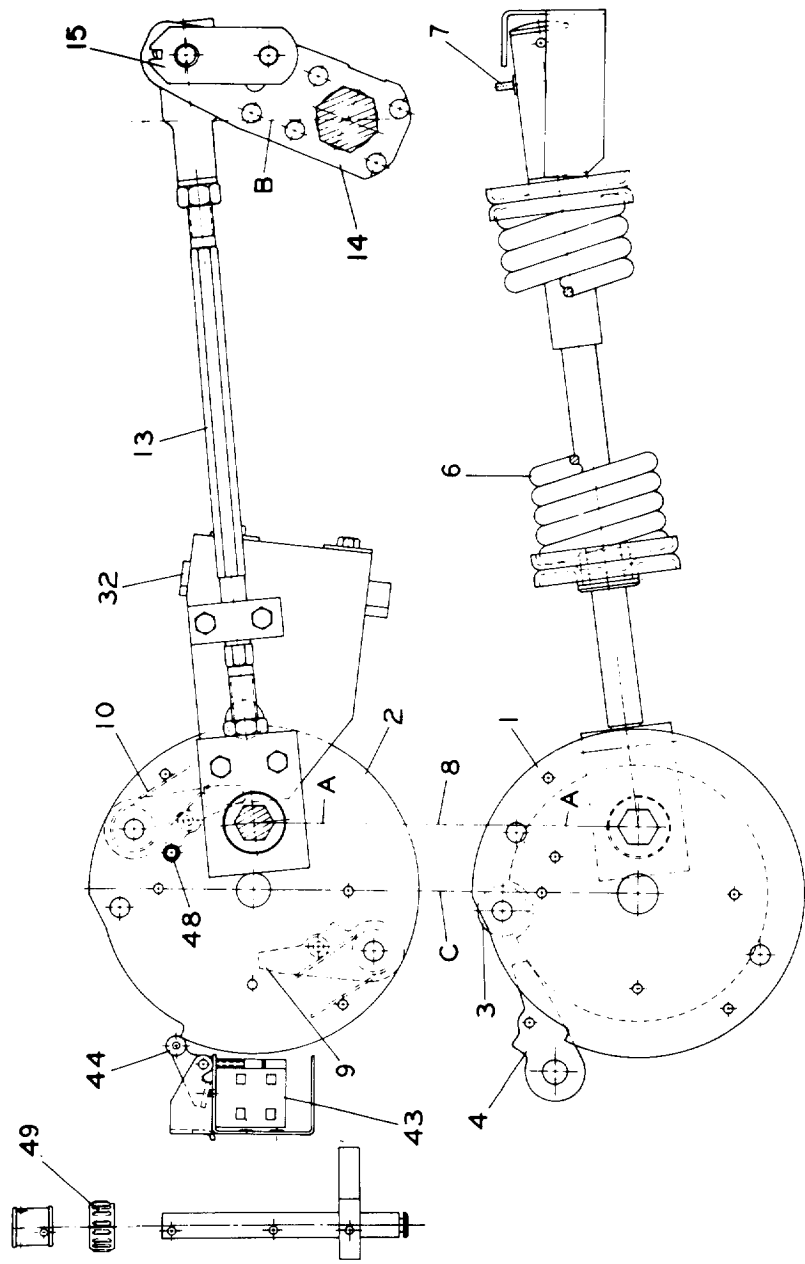
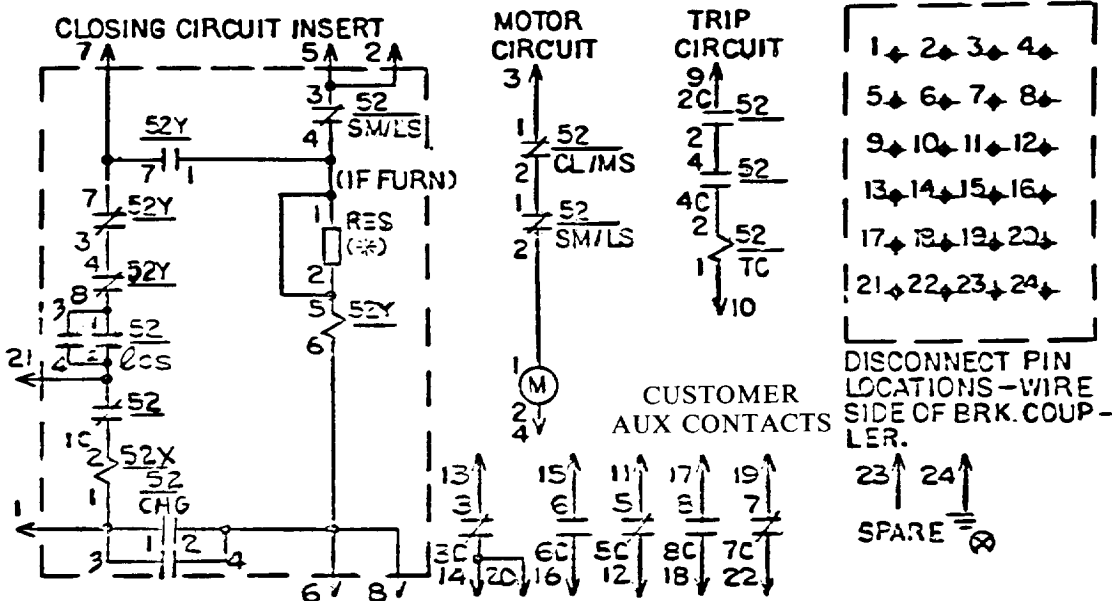
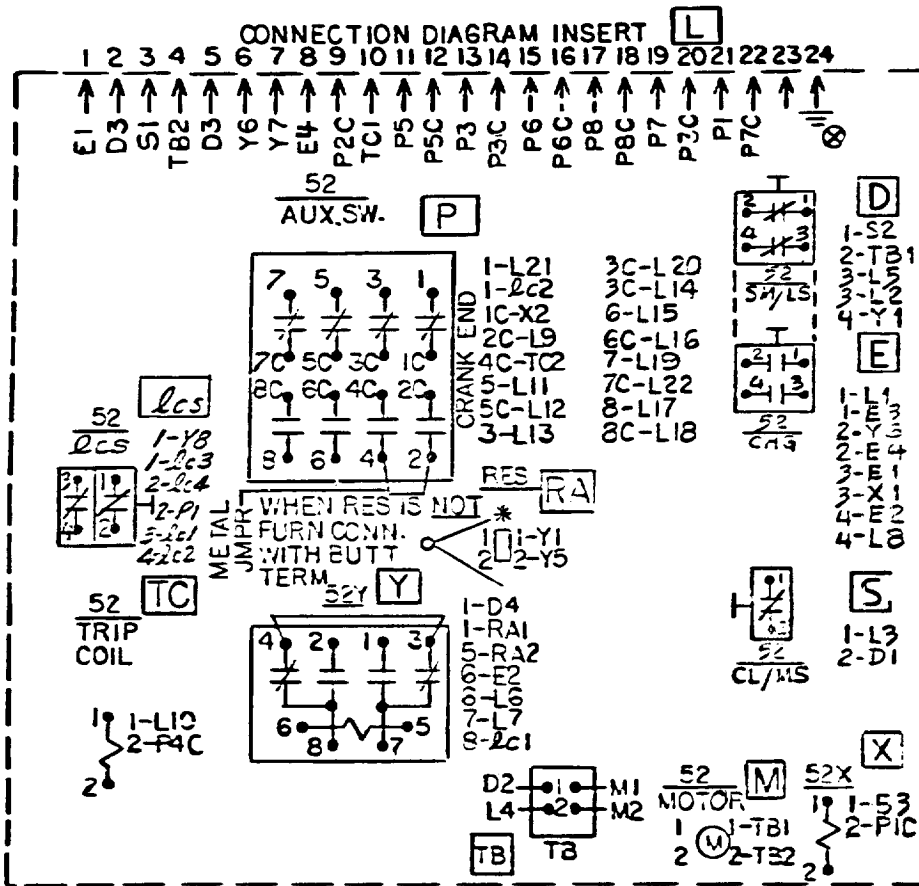

Fig. 4b Exploded Schematic — Rear View ML-17 Mechanism
For Model Designators -2 and -3

- AA Eccentric shaft connecting flywheel halves
- BB Hex shaft connecting Transfer Cranks
- CC Flywheel rotation axis
- DD Hex shaft connecting Output cranks
- 1 Rear Flywheel Section
- 2 Front Flywheel Section
- 3 Close Roller
- 4 Close Latch
- 5 Close Latch Monitor Switch
- 6 Closing Spring Assembly
- 7 Blocking Pin in Closing Spring Assembly
- 8 Hex Shaft with Connection Blocks on Flywheel
- 9 Wind Pawl
- 10 Slow Close Pawl
- 11 Wind Hub
- 12 Pawl Disengagement Cam Surface — on Frame
- 13 Pull Rod
- 14 Adjustable Throw Transfer Crank
- 15 Adjustment Link (Factory Adjustment Only)
- 16 Short Transfer Crank
- 17 Slotted Link
- 18 Trip Latch
- 19 Link — Trip Toggle to Frame
- 20 Link from Close Toggle to Trip Toggle
- 21 Link from Output Crank to Close Toggle
- 22 Output Crank
- 23 Pole 1 Bell Cranks
- 24 Wipe Spring Trunnion Block
- 25 Interrupter Operating Rod Connection
- 26 Wipe Spring
- 27 Overtravel Stop Adjustment — on Each, Pole
- 28 Horizontal Connecting Bar
- 29 Opening Spring Assembly
- 30 Opening Stop Block
- 31 Dashpot
- 32 Brake (not installed on -3 model designator)
- 33 Closing Latch Shaft
- 34 Auxiliary Switch Drive Arm
- 35 Idler Link
- 36 Switch Drive Arm
- 37 Auxiliary Switch — SB-12 — Four Stage
- 38 Position Indicator Flag
- 39 Operation Counter
- 40 Spring Charge Indicator Arm
- 41 Rod
- 42 Spring Charge-Discharge Indicator Flag
- 43 Spring Motor Limit Switch
- 44 Gear Motor Limit Switch Operator
- 45 Gearmotor
- 46 Gearmotor Housing
- 47 Trip Latch Checking Switch
- 48 Slow Close Pin
- 49 Retaining Clamp
- 50 Opening Stop
- 51 Toggle Pin
- 52 Trip Roller
- 53 Horizontal Bar Stop Locking Nut
- 54 Trip Shaft



NOTES:

- | | | |
|--|---|---|
| <p><u>52</u>
CL/MS</p> <p>Closing latch monitoring switch is closed when latch is capable of blocking fully charged closing spring. Held open between disc. & connect positions.</p> | <p><u>52X</u></p> <p>Spring release coil operates latch which releases closing spring to close <u>52</u>.</p> | <p><u>52</u>/TC</p> <p>Trip Coil operates to open <u>52</u></p> |
| <p><u>52</u>
SM/LS</p> <p>Limit switch for spring charging motor-contacts (1-2) (3-4) open when springs are fully charged.</p> | <p>⊗</p> <p>Ground pin used for inspection box only.</p> | <p>*</p> <p>See table for res. value.</p> |
| <p><u>52</u>
CHG</p> <p>Contact closed when closing springs are fully charged.</p> | <p><u>52</u>
LCS</p> <p>Triplatch checking switch closed when latch is reset.</p> | |

Fig. 5 Typical Wiring Diagram for ML-17 Mechanism

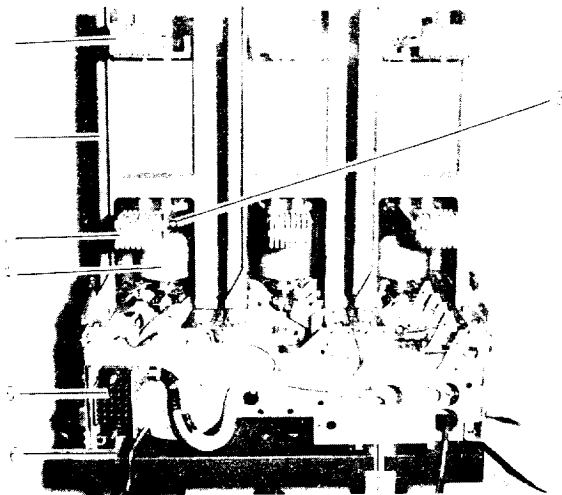
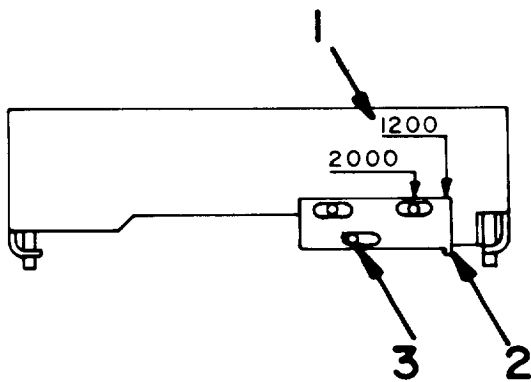

Fig. 6 Rear View of Power/Vac* Breaker Showing Rating Interference Plate

- 1 — Primary Disconnect Fingers
- 2 — Interrupter Support
- 3 — Coupling Clamp
- 4 — Operating Rod
- 5 — Secondary Disconnect Coupler
- 6 — Ground Shoe
- 7 — Rating Interference Plate



REAR VIEW
1200/2000 AMPS

Fig. 7 Rating Interference Plate — 1200/2000A Breaker

- 1 — Current Setting Indicator
- 2 — Rating Interference Plate
- 3 — Positioning Bolt

3.7.2 CLOSING SPRING DISCHARGE INTERLOCK

The function of the closing spring discharge interlock is to prevent racking into or out of metalclad a breaker with the closing spring charged. This is accomplished by a roller on the right-hand side of the mechanism, 4, Fig. 8, which contacts the racking mechanism and discharges the closing spring except if the breaker is in the "Disconnect/Test" position or the "Connect" position in the metalclad switchgear. This interlock also opens the CL/MS switch in the motor charging circuit to prevent charging the closing springs when the breaker is between the "Disconnect/Test" or "Connect" position in the metalclad.

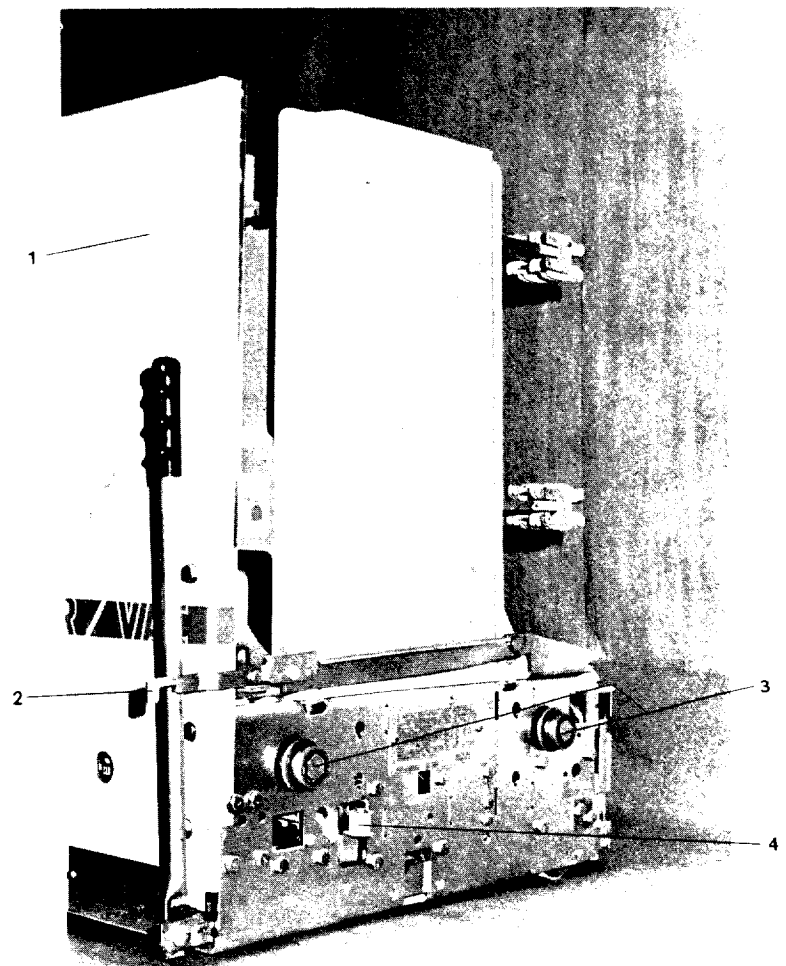

Fig. 8 Power/Vac* Breaker — Right Side View

- 1 — Front Cover
- 2 — Rackout Arm
- 3 — Rollers for Track
- 4 — Closing Spring Discharge Roller

3.7.3 NEGATIVE TRIP INTERLOCK

The function of the negative trip interlock, (5) Fig. 9, is to disengage the trip latch from the trip latch roller thereby preventing a closing operation. The interlock also opens the latch checking switch (52LCS) in the closing circuit thereby removing the close circuit power. The negative interlock is in operation while the breaker is moving between the "Disconnect/Test" position and the "Connect" position. A redundant Negative trip interlock, (6) Fig. 9, is a backup to the NEGATIVE TRIP INTERLOCK and provides the same function except it operates only near the connect position.

3.7.4 POSITIVE INTERLOCK

The positive interlock, (3) Fig. 9, operates to prevent the racking of a breaker that is closed. A linkage connected to the horizontal connecting bar extends a detent bar out from the side of the mechanism frame when it is in the closed position. If the closed breaker is in the "Connect" or "Disconnect/Test" position in the metalclad the detent bar locks into the racking mechanism to prevent access to the hex section of the jack screw. The positive interlock also prevents the lift truck from picking up a closed breaker.

3.7.5 CLOSING SPRING GAG INTERLOCK

The closing spring gag interlock is provided on the breaker to prevent a breaker that has a gagged closing spring from entering the metalclad unit. This is accomplished by projecting a lever, (1) Fig. 10, out of the left side of the mechanism when the closing spring is gagged.

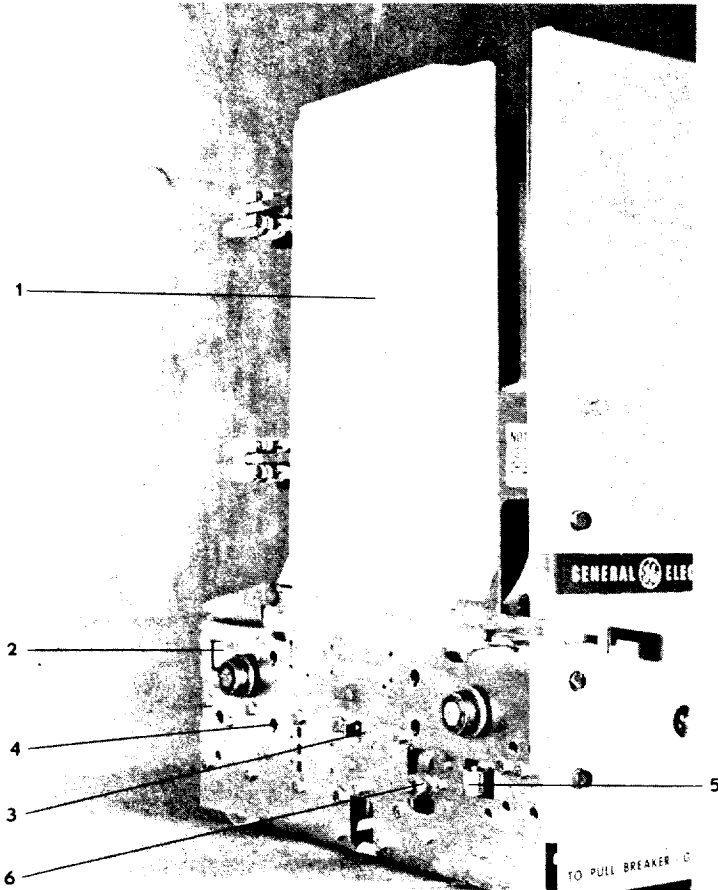

Fig. 9. Power/Vac* Breaker — Left Side View

- 1 — Interrupter Support
- 2 — Closing Spring Gag Interlock
- 3 — Positive Interlock Bar
- 4 — Trip Latch Blocking Hole
- 5 — Negative Interlock Roller
- 6 — Redundant Negative Interlock Roller

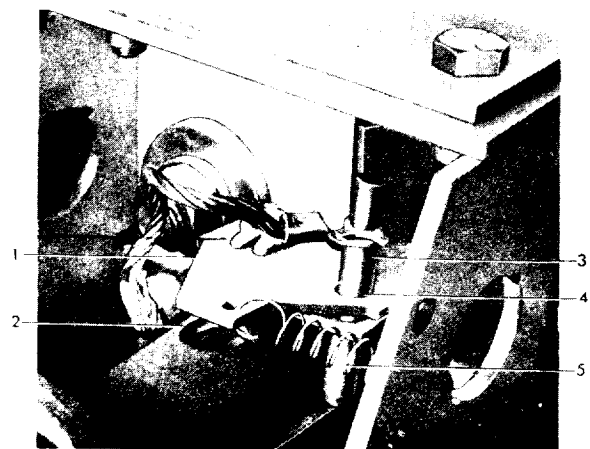

Fig. 10 Closing Spring Gag Interlock

- 1 — Close Spring Interlock Lever
- 2 — Blocking Hole
- 3 — Close Spring Blocking Pin
- 4 — Storage Hole
- 5 — Interlock Lever Return Spring

(Shown in Unblocked Position)

4. PREINSTALLATION CHECKOUT

4.1 GENERAL

Before the initial installation of the Power/Vac* circuit breaker the device should be thoroughly inspected and checked for proper operation and adjustments. Each of the items on the following list should be performed:

- (1) Check that the shipping bolt has been removed (see Shipping Position, Paragraph 4.3, for instructions). NOTE: Shipping bolt is not installed on breakers shipped inside the metalclad switchgear.
- (2) Check the breaker nameplate to see that the breaker rating is for the intended application.
- (3) Perform the inspection and mechanical checks as described in Paragraph 4.4, "Mechanical Operation".
- (4) Check the breaker control wiring and the vacuum integrity of the interrupters as described in Paragraph 4.5, "Electrical Checking".

4.2 SAFETY PRECAUTIONS

The Power/Vac* circuit breaker uses powerful springs for energy storage. **DO NOT WORK ON INTERRUPTERS OR THE MECHANISM UNLESS THE CLOSING SPRING IS EITHER DISCHARGED OR GAGGED, THE BREAKER IS OPEN OR THE TRIP LATCH LOCKING BOLT IS INSTALLED, AND ALL ELECTRICAL CONTROL POWER IS REMOVED.** These precautions are to prevent accidental operation which could cause injury to someone working on the mechanism.

ANYONE WORKING ON THE CIRCUIT BREAKER SHOULD BE FAMILIAR WITH DEVICE AS DESCRIBED IN THIS INSTRUCTION BOOK AND SHOULD BE COGNIZANT OF ALL SAFETY PRECAUTIONS.

4.3 SHIPPING POSITION

The circuit breaker has been shipped in a closed position with the mechanism trip latch blocked by a bolt through the left side frame. A yellow tag identifies this bolt. (This bolt is not installed on breakers shipped inside the metalclad switchgear.) Before operation or insertion into the metalclad equipment, this bolt must be removed and the mechanism tripped open with the manual trip button. NOTE: Save

the shipping bolt (if installed) for use in locking the breaker closed for maintenance or repair. The close spring is discharged when shipped.

After removing packing material, locate, and remove (if installed) the trip latch blocking bolt indicated with a yellow tag on the left side sheet of the mechanism. Press in on the manual trip push button, (2) Fig. 1, to trip the mechanism open, keeping hands from moving parts.

Close and open springs are now in their discharged positions. Check this by first pressing the manual close button, then the manual trip push button.

4.4 MECHANICAL OPERATION

Prior to operating the mechanism check the breaker for signs of damage or loose hardware.

Perform the slow closing operation described in Paragraph 5.2.

Check the Wipe and Gap as described in Section 5.6.2 and readjust if required. Check the erosion indication as described in Section 5.7.

4.5 ELECTRICAL CHECKING

Electrical checking consists of operating the breaker electrically and performing the vacuum interrupter integrity test plus those tests required by local operating procedures.

- (1) To check the electrical operation use the test cabinet if provided or the test position in the metalclad switchgear. Compare the available control voltage to the voltage indicated on the breaker name plate. Close and open the breaker several times to check electrical operation.
- (2) Perform a vacuum interrupter integrity test to verify the condition of the interrupters. Perform the test as described in Section 6.5.
- (3) The following additional testing may be performed if desired:
 - a. Megger® tests per para. 6.3
 - b. Primary circuit high potential per para. 6.4.1
 - c. Secondary circuit high potential per para. 6.4.2
 - d. Primary circuit resistance per para. 6.6

5. MECHANICAL CHECKS AND ADJUSTMENTS

5.1 GENERAL

Checking the mechanical adjustments may be performed in any order. However, the adjustments associated with the stroke of the mechanism must be performed in the prescribed order since they are related in such a way that the adjustment of one affects the next in the series. These adjustments and the prescribed order are:

- (1) Pull rod adjustment
- (2) Trip latch clearance
- (3) Overtravel stops
- (4) Wipe and Gap setting

For example, if the pull rod is adjusted, then the trip latch clearance must be checked and adjusted followed by resetting the overtravel stops and then checking and adjusting the wipe and gap setting. However, if only the wipe and gap setting is adjusted, it is not necessary to perform the adjustments preceding it.

When adjusting the pull rod or the trip latch clearance, the overtravel stops should be backed out of the horizontal connecting bar two turns to assure that they do not interfere with the mechanism stroke during the adjustment.

5.2 SLOW CLOSING OPERATION

Slow closing the breaker allows observation of the motion of the mechanism while manually cranking it from the open to the closed position. The slow closing operation is required when performing adjustments on the breaker such as setting the pull rod adjustment and when setting the wipe and gap.

- (1) Manually charge the breaker closing spring using a $\frac{5}{8}$ inch hex socket-ratchet-type wrench for safety, and turn in the direction of the arrow as indicated on the end of the manual wind shaft, (8) Fig. 1. Several rotations with no apparent load are necessary until the winding mechanism engages the spring-charging pawl.

As the manual charging shaft is rotated the trip latch will reset first with a small "click". Continued rotation will fully charge the closing spring and a louder sound will be heard. At this time the charge/discharge indicator (5) Fig. 1 will change from "Discharged" to "Charged". Stop cranking when this occurs.

CAUTION

CHECK THAT THE CLOSING SPRING IS FULLY CHARGED WITH THE CLOSE ROLLER, (3) Fig. 4, RESTING AGAINST THE CLOSE LATCH, (4) Fig. 4.

- (2) Insert the close spring blocking pin, (3) Fig. 10, by carefully removing it from its storage hole, rotating the interlock lever and inserting it in the blocking hole.

- (3) **CAUTION:** If the manual close button is not pressed prior to performing step 4, the breaker will be damaged. **PRESS THE MANUAL CLOSE BUTTON TO PARTIALLY DISCHARGE THE CLOSING SPRING AGAINST THE BLOCKING PIN.**

- (4) Pull the slow close pin on the flywheel, (2) Fig. 11, and resume ratchet wrench operation of the manual wind shaft. After several rotations at no apparent load, the winding mechanism will engage the slow close pawl and begin the closing operation of the mechanism.

Continue rotating the manual wind shaft. Be sure the close toggle pin, (10) Fig. 3b, goes over-center and the spacers on the ends of the pin rest against the frame. After the one-half flywheel rotation necessary for closing, the slow close pawl is automatically disengaged.

The breaker may be opened from this position by pushing the manual trip push button.

To return the breaker to the open and discharged condition, charge the closing spring as described in Step (1) above, remove the close spring blocking pin and push the manual close push button and then the manual trip push button.

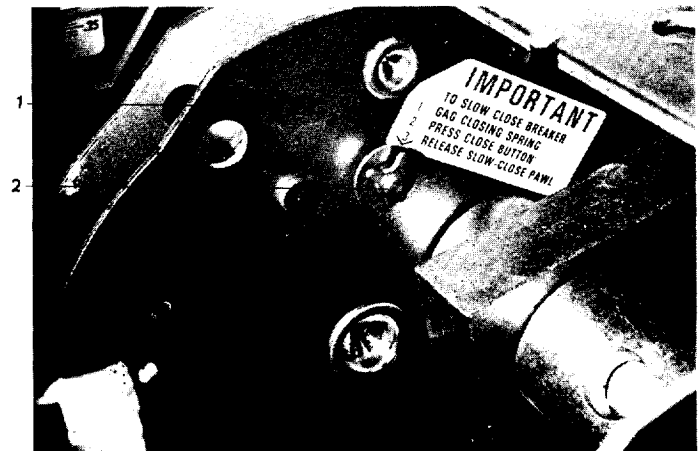

Fig. 11 Slow Close Pin On Flywheel

- 1 — Flywheel
- 2 — Slow Close Pin

5.3 PULL ROD ADJUSTMENT

Refer to Fig. 4. The pull rod (13) is a turnbuckle, with a right-hand thread at the crank and a left-hand thread at the flywheel connection. Slow close the mechanism as described in Paragraph 5.2, SLOW CLOSING. As the flywheel rotates the slotted link pulls the closing toggle pin over-center so that the spacers on the end of the pin are resting on the mechanism frame. In this position, the slotted link should be in contact with the closing toggle pin.

CAUTION: IF THE SPACERS ARE NOT AGAINST THE FRAME, THE TOGGLE LINKS MUST BE TAPPED FIRMLY DOWNWARD SO THAT THEY REST AGAINST THE FRAME.

If the slotted links do not bottom on the toggle pin, re-adjustment of the pull rod length is required. To adjust the pull rod, loosen the nuts on each end and adjust the rod length until the slotted link bottoms against the toggle pin. (NOTE: before making adjustments to the pull rod the overtravel stop bolts, (27) Fig. 4, should be backed out of the horizontal connecting bar two turns.) Increase the rod length by backing off about ¼ turn so that the slotted links are just free of the pin and can move slightly from side to side.

In this position the slotted links (17) should have no apparent clearance to the pin in the close toggle (20, 21) but should be capable of being moved axially along the pin by firm finger pressure. Tighten the pull rod lock nuts to 30-35 foot pounds of torque.

If the pull rod is too short, i.e., slotted link (17) is too tight against the pin in the closed toggle, the pin may be bent and require replacement.

5.4 TRIP LATCH CLEARANCE

Refer to Items 5 and 8 Fig. 3a. Charge and gag the close spring as described in Steps 1 and 2 of Paragraph 5.2, Slow Closing Operation. With the breaker open, determine the trip latch clearance by depressing the trip roller against the latch face from its spring-reset position. If no apparent motion exists, depress the manual trip push button and see if the trip roller rotates.

The latch clearance should be set between .005 and .040 inch. The trip roller must not rotate when the latch is moved by the manual push button. The clearance may be estimated by pressing the roller down against the latch.

To adjust, loosen the locking nut, (53) Fig. 4 (¾ hex) holding the stop bolt to the horizontal connecting bar, and then unscrew the stop bolt (¾ hex) to decrease latch clearance while pushing the manual trip push button in and out until the trip roller just starts to turn. (NOTE: Before making adjustments to the trip latch clearance the overtravel stop bolts, (8) Fig. 12, should be backed out of the horizontal connecting bar two turns.) Now, screw in on the adjusting bolt until the roller no longer turns plus an additional ¼ turn. Torque the lock nut to 55 foot-pounds while holding the adjusting screw. This sets latch clearance at a minimum and any mechanism wear will tend to increase the clearance. When 0.060 inch clearance is reached readjustment will be required.

5.5 OVERTRAVEL STOP BOLTS

Refer to Fig. 12. Six adjustable bolts, (8) are threaded into the horizontal connecting bar to provide stops for each pole to prevent overstroking the Power/Vac* interrupters. Each of these bolts should be backed out of the horizontal connecting bar two turns prior to performing adjustments to

the pull rod or to the trip latch setting. To adjust the overtravel stop bolts, back off locking nut, (11), and turn each of the six bolts, (8), in toward the opening stop block, (14), until the bolt touches the stop ring (breaker is open for this adjustment). Back off ¼ to ½ turn and tighten the locking nuts (11) to 20 to 25 foot-pounds.

5.6 WIPE AND GAP ADJUSTMENT

5.6.1 GENERAL

Wipe is the additional compression of the pre-loaded wipe spring, (5) Fig. 12, which is used to apply force to the closed vacuum interrupter contacts. Proper adjustment of the wipe springs is necessary to assure that the vacuum interrupter contacts will stay closed against the forces which tend to open them due to fault currents and to supply the propelling energy required to attain the correct opening speed needed for a clean interruption of the current.

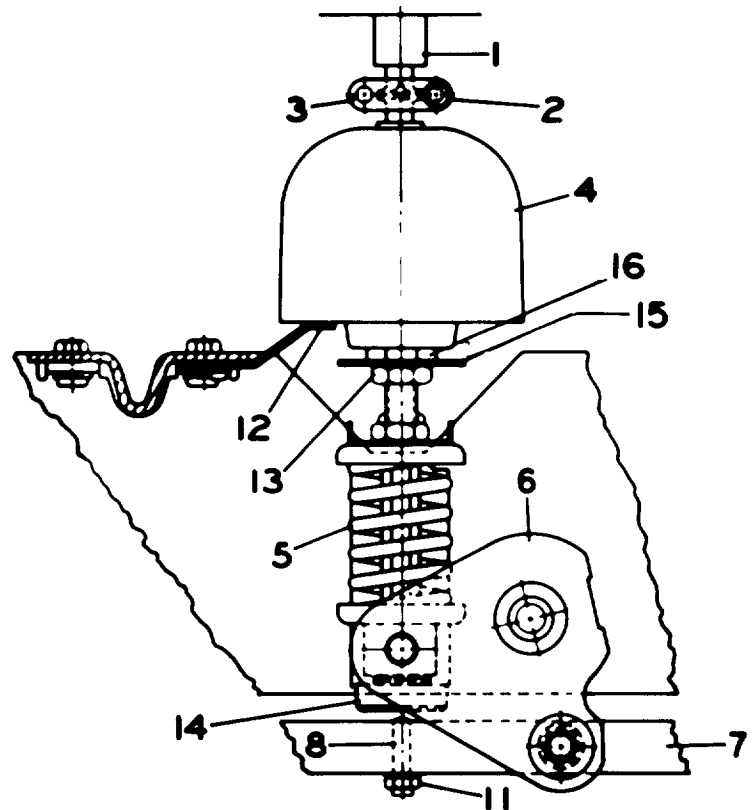

Fig. 12 Primary Contact Gap and Erosion Indication

(Breaker Open)

- | | |
|---------------------------------|-----------------------------|
| 1 — Interrupter Movable Contact | 9 — Not Used |
| 2 — Coupling Clamp | 10 — Not Used |
| 3 — Clamp Screws | 11 — Locknut |
| 4 — Operating Rod | 12 — Reference Arm |
| 5 — Wipe Spring | 13 — Locknut |
| 6 — Bell Crank | 14 — Opening Stop Block |
| 7 — Horizontal Connecting Bar | 15 — Erosion Indicator Disc |
| 8 — Overtravel Adjusting Bolt | 16 — Hex Extension |

Gap is the distance between the two vacuum interrupter contacts when the breaker is open. Correct adjustment of the gap assures that the minimum required distance for current interruption is achieved and that the distance is not so great that mechanical damage to the vacuum interrupter occurs.

Wipe and gap are related in such a way that decreasing the wipe increases the gap and increasing the wipe decreases the gap. Therefore, these two adjustments must be coordinated to bring both to within the required settings simultaneously.

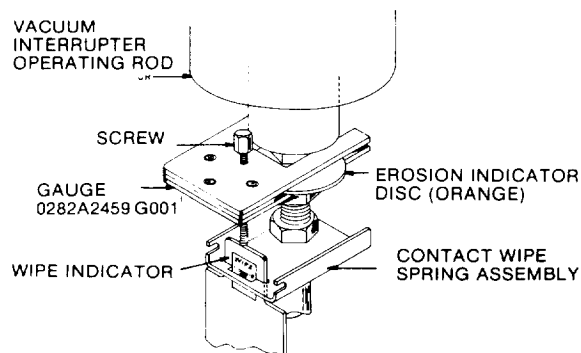

Fig. 13 Wipe Gauge

5.6.2 CHECKING

- (1) Close the breaker and block the trip latch against the frame to prevent accidental opening. Use a 3/8-16 (with 2-3/8 inch minimum thread length) bolt in the trip latch blocking hole (4) Fig. 9. Screw the bolt in until it just contacts the trip latch.
- (2) Insert gauge 0282A2459G001, Ref. Fig. 13, over the orange erosion disc and align the screw with the top of the wipe indicator. Turn the screw until it just touches the wipe indicator. Carefully hold the screw in position while removing the gauge. Measure the extension of the screw below the gauge plate bottom using a dial caliper and record this reading. Perform this measurement on all three phases.
- (3) Measure the position of the Operating Rod (4) Fig. 12, relative to the breaker frame. Measure all three phases. (SUGGESTION: place a piece of masking tape vertically on the operating rod and using a block (approx. 2" height) that spans the frames draw a line on the tape to indicate the position when the breaker is closed. Leave the tape in place and in step 6 draw another line on the tape when the breaker is opened. The distance between these lines is the gap for that phase.)
- (4) Remove the trip latch blocking bolt installed in Step 1 and open the breaker by pushing the manual trip push button.

- (5) Repeat Step No. 2 to measure the position of the wipe indicator with the breaker open. Subtract the two measurements of the screw length to obtain the wipe of each phase.
- (6) Repeat Step No. 3 to measure the position of Operating Rod with the breaker in the open position. Subtract the two measurements to obtain the vacuum interrupter contact gap for each phase. (If the suggestion in Step 3 was followed, remove the tape from the operating rod, place it on a flat surface and measure the gaps directly as the distance between the two lines on the tape.)
- (7) Compare the wipes and gap measured with the following chart:

INTERRUPTER	WIPE	GAP
PV40A1	.155 TO .180	.545 TO .600
PV41A3	.155 TO .180	.545 TO .600
PV42B1	.155 TO .180	.545 TO .600
PV50, PV52	.155 TO .180	.545 TO .600
PV42A1	.155 TO .180	.445 TO .500
ALL OTHERS	.155 TO .180	.664 TO .719

5.6.3 ADJUSTMENT

If wipe is less than 0.125" or greater than 0.185" or gap is outside limits listed above, adjustment is required.

1. Determine the amount of adjustment required to bring both the wipe and gap to within requirements.
2. Close the breaker and block the trip latch against the frame using the 3/8-16 bolt in the trip latch blocking hole.
3. Loosen but do not remove the 1/4" hex bolts holding the coupling clamp, (2) Fig. 12. Be sure that the clamp can be rotated freely by hand.
4. Hold the hexagon projection at the bottom of the Operating Rod (1-1/8" wrench) and loosen the adjacent lock nut (13) Fig. 12 (15/16" wrench).
5. Decrease the wipe (and increase the gap a like amount) by turning the Operating Rod down (clockwise looking from the top) or increase the wipe (while decreasing the gap) by turning the Operating Rod up (counterclockwise looking from the top).

NOTE: The Operating Rod has 11 threads per inch so that 1/6 turn (one flat) of the Operating Rod hex will result in approximately .015 change in wipe and gap.

6. After completing the adjustment, torque the Operating Rod Locknut, (13) Fig. 12, to 40-50 foot-pounds while preventing the Operating Rod from turning. Tighten the coupling clamp screws to 10-12 foot-pounds.
7. Remove the trip latch blocking bolt and trip the breaker open. Recheck the wipe and gap and readjust if necessary.

8. If both wipe and gap cannot be brought into the required settings, check the pull rod adjustment and the trip latch clearance. Increase the trip latch clearance to decrease the sum of the wipe and gap or decrease the trip latch clearance to increase the sum of the wipe and gap. NOTE: Do not exceed the specified range of settings on the trip latch.

5.7 PRIMARY CONTACT EROSION INDICATION

In the closed position, the indicator disc, (15) Fig. 12, below the operating rod is aligned with a reference arm (12) on new interrupters. With the breaker in the closed position, the indicator disc after inservice fault interruptions will move upward from alignment with the reference point due to contact erosion. Contact erosion will decrease the wipe which may be brought back to normal by performing wipe adjustment. When erosion reaches $\frac{1}{8}$ inch (the misalignment of the indicator disc and the reference arm with the breaker closed) the interrupter should be replaced.

If an appreciable amount (but less than $\frac{1}{8}$ " of erosion is indicated, estimate the amount of interrupter life remaining before the $\frac{1}{8}$ " limit will be reached. Recheck the erosion indicator before reaching the estimated end of life.

Do not readjust the alignment of the erosion indicator except when installing a new vacuum interrupter assembly or replacing the operating rod.

5.8 CONTROL COIL PLUNGER TRAVEL

5.8.1 TRIP COIL

With the breaker in the open position and the closing springs charged and gagged, make certain that the trip linkage and trip shaft move freely over the full plunger travel.

5.8.2 CLOSE COIL

With the breaker open and the closing spring discharged operate the plunger in the same manner as described above for the trip coil. Make certain that the plunger moves freely over its full stroke in the coil.

5.9 CONTROL SWITCHES

There are two switch locations on the right-hand side of the mechanism (viewed from the front) and one on the left. The single switch on the right-hand side (CL/MS) is toward the front of the mechanism and monitors the closing latch position. This switch should be adjusted to have the paddle $\frac{1}{32}$ to $\frac{1}{64}$ inch from the face of the switch as shown in Fig. 14a with the breaker open and the closing spring discharged.

The two switches mounted adjacent to the flywheel, see Fig. 14b, are: (1) the spring motor limit switch (SM/LS) which controls the spring charging motor and the anti-pump relay and (2), the closing spring charge switch, (52CHG), which prevents operation of the close coil unless the closing spring is charged. These switches should be adjusted in their operated position, closing spring discharged, so that there is $\frac{1}{64}$ to $\frac{1}{32}$ inch clearance between the roller (3) and the flywheel (2). Bolts (5) can be loosened to make this adjustment.

On the left-hand side is the latch checking switch (52/LCS) which monitors the position of the trip latch, see Fig. 14c. On some breakers the paddle for this switch is spring steel and requires no adjustment. On those breakers with a rigid paddle the switch should be adjusted so that there is $\frac{1}{64}$ to $\frac{1}{32}$ inch between the paddle and the switch support.

(a) CLOSE LATCH MONITOR SWITCH

- 1 — Close Shaft
- 2 — Switch Paddle
- 3 — Switch

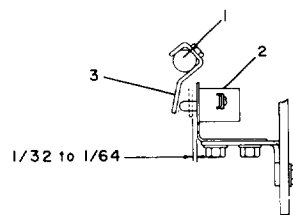

(b) SPRING MOTOR LIMIT SWITCH AND 52 CHARGE SWITCH

- 1 — Switch
- 2 — Flywheel
- 3 — Operating Arm
- 4 — Support Bracket
- 5 — Switch Adjusting Screws
- 6 — Operator
- 7 — Support
- 8 — Roller

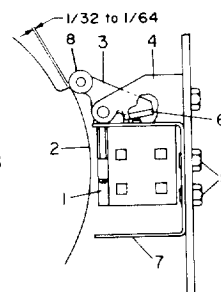

(c) LATCH CHECKING SWITCH

- 1 — Trip Shaft
- 2 — Switch Paddle
- 3 — Switch

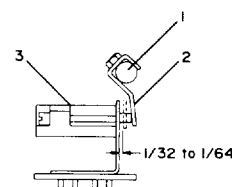

Fig. 14 Control Switches

6. ELECTRICAL CHECKS

6.1 CONTROL POWER

Control power for electrical operation of the breaker may be from either an alternating or direct current source. The operating ranges for the closing, tripping and spring charging motor voltages are specified on the breaker nameplate.

If the closed circuit voltage at the terminals of the coil or motor does not fall in the specified range, check the voltage at the source of power and line drop between the power source and breaker.

When two or more breakers operating from the same control power source are required to close simultaneously, the closed circuit voltage at the closing coil or motor of each breaker must fall within the range specified on the breaker nameplate.

6.2 TIMING

Timing may be checked by monitoring the control circuit voltage and by using a low voltage signal through the vacuum interrupter contacts to indicate the closed or open position. Typical time ranges vary with coil voltages but nominal values are:

Initiation of trip signal to contact parting

5 cycle breaker	.035 to .050 seconds
3 cycle breakers	.025 to .030 seconds

Initiation of close signal to contact closing

standard breaker	.060 to .100 seconds
fast bus transfer brkr	.062 seconds max
Instantaneous reclose time*	.128 to .221 seconds

*Time from application of trip signal and close signal until breaker opens and recloses.

6.3 MEGGER®

Since definite limits cannot be given for satisfactory insulation values, a record should be kept of the megohmmeter readings as well as temperature and humidity readings. This record should be used to detect any weakening of the insulation from one check period to the next.

The primary circuit insulation on the breaker may be checked phase to phase and phase to ground using a 2500V megohmmeter.

To measure the breaker secondary circuit insulation resistance, thread a wire connecting all secondary disconnect pins together except pin #24 (ground pin) and pins 3 and 4 (motor). The measurement may be made by connecting a 500V megohmmeter between the wire and ground.

6.4 HIGH-POTENTIAL TEST

Prior to performing the test use a dry, non-linting cloth or industrial type wiper to clean accessible insulation surfaces on the interrupter supports and operating rod insulators.

If high potential tests to check the integrity of the insulation are required, the AC high potential test described is **STRONGLY** recommended. DC high potential testing is not recommended except for the vacuum interrupter integrity test. The following procedure must be adhered to.

CAUTION: IF DC HIGH POTENTIAL TESTING IS REQUIRED, THE DC HIGH POTENTIAL MACHINE MUST NOT PRODUCE PEAK VOLTAGES EXCEEDING 50 KV.

6.4.1 PRIMARY CIRCUIT

The breaker should be hipotted closed. An AC hipot machine capable of producing the test voltages shown below may be used to hipot the breaker phase to phase and phase to ground.

BREAKER VOLTAGE RATING	TEST VOLTAGE 60 HZ (RMS)
4.16 KV	14 KV
7.2 KV	27 KV
13.8 KV	27 KV

The machine should be connected with its output potential at zero and the voltage increased to the test voltage and that voltage maintained for 60 seconds. The voltage should then be returned to zero and the hipot machine removed from the circuit. **NOTE:** Do not exceed the test voltage indicated for the applicable breaker voltage rating.

6.4.2 SECONDARY CIRCUIT

To hipot the breaker secondary circuit, thread a wire connecting all secondary disconnect pins together except pin #24 (ground pin) and pins 3 and 4 (motor). Connect the hipot machine from this wire to ground. Increase the voltage to 1125 volts (rms) 60 Hz and maintain for 60 seconds. Reduce the voltage to zero and remove the hipot machine from the circuit. Remove the wire connecting the secondary disconnect pins.

6.5 VACUUM INTERRUPTER INTEGRITY TEST

X-Radiation may be produced if an abnormally high voltage is applied across a pair of electrodes in a vacuum. X-Radiation may increase with an increase in voltage and/or a decrease in contact separation. **CAUTION: DO NOT APPLY VOLTAGE THAT IS HIGHER THAN THE RECOMMENDED VALUE. DO NOT USE CONTACT SEPARATION THAT IS LESS THAN THE NORMAL OPEN POSITION OF THE BREAKER CONTACTS.**

During a high potential or a vacuum integrity test any X-Radiation which may be produced will not be hazardous at a distance safe for high potential testing if the test is conducted at the recommended voltage and with the normal open circuit breaker contact separation.

This test of the vacuum interrupter will determine its internal dielectric condition and vacuum integrity. With the breaker open individually check each interrupter by connecting the hipot machine "hot" lead to the upper stud and the ground lead to the lower stud. If the machine has a center point ground, the connections may be made either way. Apply 36kV (rms) 60 Hz or 50KV DC (except for P/V 42A interrupters apply 19kV (rms) 60 Hz or 27 KV DC) and hold a minimum of five (5) seconds. If no breakdown occurs the interrupter is in acceptable condition. If a breakdown occurs, the interrupter should be replaced.

No attempt should be made to compare the condition of one vacuum interrupter with another nor to correlate the condition of any interrupter to low values of DC leakage current. There is no significant correlation.

After the high potential voltage is removed, discharge any electrical charge that may be retained.

CAUTION: MANY DC HIGH POTENTIAL MACHINES ARE HALFWAVE RECTIFIERS. THIS TYPE OF HIPOT TESTER MUST NOT BE USED TO TEST VACUUM INTERRUPTERS. THE CAPACITANCE OF THE POWER/VAC* BOTTLES IS VERY LOW AND

THE LEAKAGE IN THE RECTIFIER AND ITS DC VOLTAGE MEASURING EQUIPMENT IS SUCH THAT THE PULSE FROM THE HALFWAVE RECTIFIER MAY BE IN THE NEIGHBORHOOD OF 120kV WHEN THE METER IS ACTUALLY READING 40kV. IN THIS CASE, SOME PERFECTLY GOOD BOTTLES CAN SHOW A RELATIVELY HIGH LEAKAGE CURRENT SINCE IT IS THE PEAK VOLTAGE OF 120kV THAT IS PRODUCING ERRONEOUS BOTTLE LEAKAGE CURRENT. IN ADDITION, ABNORMAL X-RADIATION MAY BE PRODUCED.

An acceptable high potential machine is available from the Switchgear Business Department, Burlington, Iowa, Catalog Number 282A2610P001. The following machines are also acceptable:

Hipotronics	Model 860PL
Hipotronics	Model 880PL
Hipotronics	Model 7BT60A
James G. Biddle	Catalog 222060

6.6 PRIMARY CIRCUIT RESISTANCE

A resistance check of the primary circuit may be made with the breaker closed. Use a low resistance measuring instrument which measures microhms. The 100 ampere reading should not exceed 100 microhms when connected across the primary studs on the breaker side of the disconnect fingers.

7. MAINTENANCE

7.1 GENERAL

Power/Vac* circuit breakers have been designed to be as maintenance free as practicable. They include features such as sealed vacuum interrupters and long life synthetic greases which contribute to many years of trouble free performance with a minimum amount of maintenance attention.

7.2 SERVICE CONDITIONS

The frequency of required maintenance depends on the severity of the service conditions of the switchgear application. If the service conditions are mild the interval between maintenance operations may be extended to 10 years or 10,000 no load or normal load switching operations.

Mild service conditions are defined as an environment in which the switchgear is protected from the deleterious effects of conditions such as:

Salt Atmosphere

Changes in temperature that produce condensation
 Conductive and/or abrasive dust
 Damaging chemicals and fumes
 Vibration or mechanical shock
 High relative humidity (>90%)
 Temperature extremes (<-30°C, >40°C)

7.3 FAULT INTERRUPTIONS

The erosion rate of the primary contacts in the vacuum interrupters is very low for no load and normal load switching operations. However, fault current interruptions at or near the breaker rating may result in appreciable contact erosion. With frequent fault interruptions it is necessary to perform maintenance based on the number of interruptions. After each 15 fault interruptions the following should be performed.

1. Contact erosion per paragraph 5.7
2. Wipe and gap per paragraph 5.6
3. Vacuum interrupter integrity test per paragraph 6.5.

7.4 RECOMMENDED MAINTENANCE

The following operations should be performed at each maintenance.

1. Perform a visual inspection of the breaker. Check for loose or damaged parts.
2. Perform the slow closing operation described in paragraph 5.2.

3. Check the erosion indicator and the wipe and gap as described in paragraphs 5.6 and 5.7.

4. Perform the vacuum interrupter integrity test as described in paragraph 6.5.

5. Lubricate the breaker operating mechanism as described in paragraph 7.5.

6. Check the electrical operation using the test cabinet (if available) or the test position in the metalclad switchgear (Refer to paragraph 6.1).

7. Examine the movable contact rod of the vacuum interrupter. With the breaker open, wipe the lubricant off the rod and examine the silver surface. The rod should have a burnished appearance without copper appearing through the silver. If copper is visible at more than one location per pole, or if the silver plating is torn, the interrupter assembly should be replaced. Relubricate movable contact rod with 0282A2048P009 grease.

8. If desired, perform the additional electrical tests of paragraph 4.5.3 (Megger, primary and secondary high potential, and primary circuit resistance).

7.5 LUBRICATION

Proper lubrication is important for maintaining reliable circuit breaker performance. The ML-17 mechanism uses

bearings which have a synthetic lining in some locations. these bearings do not require lubrication to maintain low friction, but lubrication does not harm them and oiling lightly is recommended. Sleeve bearings are used in some linkage locations and needle or roller bearings are used for low friction on the flywheel, trip shaft, and close shaft.

Providing a fresh lubricant supply at periodic intervals is helpful in extending the useful life of the breaker mechanism especially where frequent operation may have forced lubricant out of the bearing surfaces. Apply a few drops of synthetic oil such as Mobil 1 at each bearing. Apply a few drops on the closing spring guide rod where it enters its sleeve inside the spring. To other rubbing surfaces apply a coating of 0282A2048P009 grease.

Electrical primary contact surfaces also require periodic lubrication to inhibit oxidation and minimize friction. At each inspection and maintenance interval, do the following:

- (1) Metal contact surfaces such as the movable contact rod of the interrupter should be lubricated with 0282A2048-P009 grease. This grease is available packaged in 4-ounce collapsible tubes.
- (2) Silvered primary contact surfaces. Wipe clean and apply a light coat of 0282A2048P009 grease on primary disconnect fingers.
- (3) Pins of the secondary disconnect coupler should be lightly coated with 0282A2048P009 grease.

APPENDIX A

RECOMMENDED SPARE PARTS AND REPAIR PROCEDURES

ILLUSTRATIONS

Figure No.		Page No.
A1	Power/ Vac* Breaker with Front Angle Plate Removed	34
A2	Operating Rod — Viewed from Rear	35
A3	Trip Coil	36
A4	Close Coil	36
A5	Secondary Disconnect	37
A6	Secondary Disconnect Pins Being Removed	37
A7	Electrical Components	38
A8	Spring Charging Motor	38
A9a	52 Auxiliary Switch	39
A9b	52 Auxiliary Switch Adjustment	39
A10a	Flywheel Brake	39
A10b	Pull Rod	40
A11	Opening Stop Bolt	41
A12	Toggle Pin	41
A13	Close Roller	41
A14	Trip Shaft (Forward) Removal	42
A15	Close Shaft (Forward) Removal	42
A16	Close Shaft (Rear)	43
A17	Spring Discharge Interlock	44
A18	Negative and Redundant Negative Interlock	44
A19	Closing Spring Gag Interlock	45

CONTENTS

	Page
A.1 Scope	27
A.2 Recommended Renewal Parts	27
A.3 Repair Parts	27
A.4 Ordering Instructions	27
A.5 Repair and Parts Replacement Procedures	34
A.5.1 General	34
A.5.2 Pin Retaining Rings	34
A.5.3 Front Angle Plate and Charge/ Discharge Flag Operating Rod	34
A.5.4 Clutch Assembly	35
A.5.5 Operations Counter	35
A.5.6 Swivel Caster	35
A.5.7 Coupling Clamp	35
A.5.8 Replacement of Interrupter Assembly	35
A.5.9 Primary Disconnect Contact Assembly	35
A.5.10 Operating Rod Insulator	36
A.5.11 Control Switches	36
A.5.12 Gearmotor Limit Switch Operator	36
A.5.13 Trip or Close Coil	36
A.5.14 Secondary Disconnect Block and Pins	37
A.5.15 Wiring Harness	37
A.5.16 Secondary Disconnect Handle	37
A.5.17 Anti-Pump Relay (Y-Relay)	37
A.5.18 Spring Charging Motor	38
A.5.19 Auxiliary Switch (52 Aux. Switch)	38
A.5.20 Fly Wheel Brake	39
A.5.21 Pull Rod	40
A.5.22 Dashpot	40
A.5.23 Overtravel Stop Bolts	40
A.5.24 Opening Stop Bolt	40
A.5.25 Toggle Pin	41
A.5.26 Trip Roller	41
A.5.27 Close Roller	41
A.5.28 Trip Shaft Assembly (Forward)	42
A.5.29 Close Shaft Assembly (Forward)	42
A.5.30 Closing Shaft (Rear)	42
A.5.31 Closing Spring	43
A.5.32 Flywheel Assembly	43
A.5.33 Spring Discharge Interlock	43
A.5.34 Negative Interlock	44
A.5.35 Redundant Negative Interlock	44
A.5.36 Closing Spring Gag Interlock	44
A.5.37 Rackout Arm Assembly (Standard)	45
A.5.38 Rackout Arm Assembly (Seismic)	45

APPENDIX A

RECOMMENDED SPARE PARTS AND REPAIR PROCEDURES

A.1 SCOPE

This Appendix provides a list of recommended spare parts for the Power/Vac* breaker and parts replacement procedures required in the event that repairs to the breaker are needed.

A.2 RECOMMENDED SPARE PARTS

It is recommended that sufficient spare parts be carried in stock to enable the prompt replacement of any worn, broken or damaged part. A stock of such parts minimizes service interruptions caused by breakdowns and saves time and expense. When continuous operation is a primary consideration, more renewal parts should be carried, the amount depending on the severity of the service and the time required to secure replacements.

Spare or replacement parts which are furnished may not be identical to the original parts, since improvements are made from time to time. The parts which are furnished, however, will be interchangeable. Table A.1 lists the recommended spare parts to be carried in stock by the user. The recommended quantity is not specified. This must be determined by the user based on the application.

A.3 REPAIR PARTS

Renewal Parts Bulletin GEF 4705 lists the replacement parts for the Power/Vac* breaker which may be installed by a skilled mechanic using commonly available hand tools. It is not recommended that a stock of these parts be carried since their expected life is in general independent of the severity of the application and exceeds the expected useful lifetime of the breaker.

In the event that it is necessary to replace a component not listed in either Table A.1 or the Replacement Parts Bulletin, contact the General Electric Company for recommendations.

A.4 ORDERING INSTRUCTIONS

1. Always specify complete nameplate data, including:
 - A. Type
 - B. Serial No.
 - C. Rated Voltage
 - D. Rated Amps
 - E. Impulse Withstand
 - F. Interrupting Time
 - G. Interrupter Type
 - H. Control Voltage (if applicable)
2. Specify the quantity, catalog number and description of each part ordered.

NOTE: Standard hardware such as screws, bolts, nuts, etc., is not provided. Such items of comparable quality should be purchased locally.

RECOMMENDED SPARE PARTS FOR POWER/VAC BREAKERS WITH ML-17 MECHANISM

NO. REQ'D PER BRKR.	MODEL DESIGNATOR	DESCRIPTION	CATALOG NO.
1	0, 1, 2	Spring-Charging Motor 48 V-DC 125 V-DC & 120 V-AC 250 V-DC & 240 V-AC	0282A5222G004 0282A5222G002 0282A5222G003
1	3	Spring-Charging Motor 48 V-DC 125 V-DC & 120 V-AC 250 V-DC & 240 V-AC	0177C2164G003 0177C2164G001 0177C2164G002
1	ALL	Relay (Non-Nuclear) 48 V-DC 125 V-DC 250 V-DC 120 V - 60 Hz 240 V - 60 Hz 120 V - 50 Hz 240 V - 50 Hz	0282A2008P001 0282A2008P002 0282A2008G001 0282A2008P003 0282A2008P004 0282A2008P005 0282A2008P006
		Relay (Nuclear Only) 48 V-DC 125 V-DC 250 V-DC 120 V - 60 Hz 240 V - 60 Hz 120 V - 50 Hz 240 V - 50 Hz	0282A2628P001 0282A2628P002 0282A2628G001 0282A2628P003 0282A2628P004 0282A2628P005 0282A2628P006
1 or 2 As Req'd.	ALL	Potential Trip Coil (5 Cycle) 48 V-DC 125 V-DC 250 V-DC Potential Trip Coil (3 Cycle) 48 V-DC 125 V-DC 250 V-DC	0282A2009P007 0282A2009P008 0282A2009P009 0282A2009P001 0282A2009P002 0282A2009P003

RECOMMENDED SPARE PARTS FOR POWER/VAC BREAKERS WITH ML-17 MECHANISM

NO. REQ'D PER BRKR.	MODEL DESIGNATOR	DESCRIPTION	CATALOG NO.
1	ALL	Closing Coil (STD) 48 V-DC 125 V-DC 250 V-DC 120 V-AC 240 V-AC Closing Coil (FBT) * 48 V-DC 125 V-DC 250 V-DC 240 V-AC	0282A2009P001 0282A2009P002 0282A2009P003 0282A2009P004 0282A2009P005 0282A2009P014 0282A2009P001 0282A2009P002 0282A2009P004
1 ∅	ALL	Undervoltage Trip Device 48 V-DC 125 V-DC 250 V-DC	0282A5218G001 0282A5218G002 0282A5218G003
2 ** 1 or 2 1 1	ALL ALL 0 1, 2, 3	Control Switch, Normally Open Control Switch, Normally Closed Auxiliary Switch Auxiliary Switch	0282A2097P003 0282A2097P002 0177C2114P001 0209B3410P001

* BREAKERS WITH FOLLOWING ON NAMEPLATE:

"TRANSFER DEAD TIME WITH LOAD 3 CYCLE - USE WITH LIKE BREAKER."

** ALSO USED FOR FAST BUS TRANSFER CONTACT ON THOSE BREAKERS WITH NOTE "*" ON NAMEPLATE.

∅ ONLY FOR BREAKERS ORIGINALLY FURNISHED WITH UNDERVOLTAGE TRIP DEVICES.

**RECOMMENDED SPARE PARTS FOR POWER/VAC BREAKERS
WITH ML-17 MECHANISM**

**INTERRUPTER ASSEMBLY
(POLE UNIT COMPLETE)**

BREAKER TYPE	MODEL DESIGNATOR NUMBER	CONTINUOUS CURRENT, AMPERES	C & L CURRENT RATING, KA	TYPE APPLICATION	QTY. REQ'D	CATALOG NUMBER
VB - 4.16 - 250	0	1200	58	STANDARD	3	0282A2751G 073
	0	1200	78		3	074
	0	2000	58		3	075
	0	2000	78		3	076
	1, 2	1200	58		3	041
	1, 2	1200	78		3	042
	1, 2	2000	58		3	043
	1, 2	2000	78		3	044
	1, 2	1200/2000	58		3	063
	1, 2	1200/2000	78		3	064
	3	1200	58	STANDARD & SEISMIC	3	077
	3	1200	78		3	078
	3	2000	58		3	079
	3	2000	78		3	080
	3	1200/2000	58		3	081
	3	1200/2000	78		3	082
	1, 2	1200	58	SEISMIC & NUCLEAR	3	053
	1, 2	1200	78		3	053
	1, 2	2000	58		3	055
	1, 2	2000	78		3	055
	1, 2	1200/2000	58		3	069
1, 2	1200/2000	78	3		069	
VB - 4.16 - 350	3	1200	58	NUCLEAR	3	053
	3	1200	78		3	053
	3	2000	58		3	055
	3	2000	78		3	055
	3	1200/2000	58		3	069
	3	1200/2000	78		3	069
	0, 1, 2, 3	1200	78		STANDARD SEISMIC NUCLEAR	3
	0, 1, 2, 3	2000	78	3		046
	0, 1, 2, 3	3000	78	3		047
	0, 1, 2, 3	1200/2000	78	3		065

MODEL DESIGNATOR NO. "0" REPRESENTS NO NUMBER IMMEDIATELY AFTER THE NOMINAL MVA IN TYPE DESIGNATION.

1200/2000 ARE SPARE BREAKER WITH A DUAL RATING.

RECOMMENDED SPARE PARTS FOR POWER/VAC BREAKERS
WITH ML-17 MECHANISM

INTERRUPTER ASSEMBLY
(POLE UNIT COMPLETE)

BREAKER TYPE	MODEL DESIGNATOR NUMBER	CONTINUOUS CURRENT, AMPERES	C & L CURRENT RATING, KA	TYPE APPLICATION	QTY. REQ'D	CATALOG NUMBER
VB - 7.2 - 500	0, 1, 2	1200	66	STANDARD SEISMIC NUCLEAR	3	0282A2751G 048
	0, 1, 2	1200	78		3	049
	0, 1, 2	2000	66		3	050
	0, 1, 2	2000	78		3	051
	0, 1, 2	1200/2000	66		3	066
	0, 1, 2	1200/2000	78		3	067
	3	1200	66		3	083
	3	1200	78		3	084
	3	2000	66		3	085
	3	2000	78		3	086
	3	1200/2000	66		3	087
	3	1200/2000	78		3	088
VB - 13.8 - 500	0, 1, 2	1200	37	STANDARD	3	0282A2751G 052
	0, 1, 2	2000	37		3	054
	0, 1, 2	1200/2000	37		3	068
	0, 1, 2	1200	37	SEISMIC NUCLEAR	3	053
	0, 1, 2	2000	37		3	055
	0, 1, 2	1200/2000	37		3	069
	3	1200	37	STANDARD SEISMIC	3	052
	3	2000	37		3	054
	3	1200/2000	37		3	068
	3	1200	37	NUCLEAR	3	053
	3	2000	37		3	055
	3	1200/2000	37		3	069
	0, 1, 2	1200	58	STANDARD SEISMIC NUCLEAR	3	053
	0, 1, 2	2000	58		3	055
	0, 1, 2	1200/2000	58		3	069
	3	1200	58	STANDARD SEISMIC	3	089
	3	2000	58		3	090
	3	1200/2000	58		3	091
3	1200	58	NUCLEAR	3	053	
3	2000	58		3	055	
3	1200/2000	58		3	069	

RECOMMENDED SPARE PARTS FOR POWER/VAC BREAKERS
WITH ML-17 MECHANISM

INTERRUPTER ASSEMBLY
(POLE UNIT COMPLETE)

BREAKER TYPE	MODEL DESIGNATOR NUMBER	CONTINUOUS CURRENT, AMPERES	C & L CURRENT RATING, KA	TYPE APPLICATION	QTY. REQ'D	CATALOG NUMBER
VB-13.8-750	0, 1, 2, 3	1200	58	STANDARD SEISMIC NUCLEAR	3	0282A2751G 056
	0, 1, 2, 3	1200	77		3	057
	0, 1, 2, 3	2000	58		3	058
	0, 1, 2, 3	2000	77		3	059
	0, 1, 2, 3	1200/2000	58		3	070
	0, 1, 2, 3	1200/2000	77		3	071
VB-13.8-1000	0, 1, 2, 3	1200	77	STANDARD SEISMIC NUCLEAR	3	0282A2751G 060
	0, 1, 2, 3	2000	77		3	061
	0, 1, 2, 3	3000	77		3	062
	0, 1, 2, 3	1200/2000	77		3	072

RECOMMENDED SPARE PARTS FOR POWER/VAC BREAKERS
WITH ML-17 MECHANISM

DESCRIPTION	CATALOG NUMBER	MODEL DESIGNATOR	QUANTITY PER BREAKER															
			1200		2000		1200/2000											
			37	58/66	77/78	37	58/66	77/78	37	58/66	77/78	1200/2000	3000					
PRIMARY DISCONNECT CONTACT ASM.	0282A2725G002	0, 1, 2, 3	6															
	0282A2700G003	0, 1, 2, 3		6														
	0282A2700G004	0, 1, 2, 3			6	6												
	0282A2701G002	0, 1, 2, 3		6														
	0282A2702G001	0, 1, 2, 3																6
	0282A2834G002	0, 1, 2, 3								6	6							6
OPERATING ROD	0209B3401G001	0, 1, 2, 3	3	3	3	3	3	3	3	3	3	3	3	3	3	3	3	3

A.5 REPAIR AND PARTS REPLACEMENT PROCEDURES

A.5.1 GENERAL

The repair and parts replacement procedures which follow assume that the work is being performed by skilled personnel knowledgeable of the details of the mechanism and the principles of its operation and the safety precautions applicable to each operation. The breaker mechanism contains powerful springs containing sufficient stored energy to cause severe injury if released unexpectedly or in an uncontrolled manner.

CAUTION

ALL REPAIR WORK ON THE MECHANISM SHOULD BE PERFORMED WITH THE BREAKER OPEN AND THE CLOSING SPRING DISCHARGED EXCEPT AS SPECIFICALLY REQUIRED BY THE FOLLOWING PROCEDURES.

WHEN IT IS NECESSARY TO WORK ON A CLOSED BREAKER THE TRIP LATCH BLOCKING BOLT SHOULD BE INSTALLED TO PREVENT INADVERTENT TRIPPING.

WHEN IT IS NECESSARY TO WORK ON A BREAKER WITH THE CLOSING SPRING CHARGED, IT SHOULD BE GAGGED TO PREVENT INADVERTENT CLOSING.

In some of the procedures which follow it is necessary to tilt the breaker on its side to gain the required access. This should be done carefully by two or more persons to assure that the breaker is not damaged and that no one is injured by allowing it to fall.

CAUTION

THE BREAKER SHOULD BE OPENED AND THE CLOSING SPRING DISCHARGED BEFORE PLACING IT ON ITS SIDE SINCE THE NEGATIVE (IF TIPPED ON THE LEFT SIDE) OR THE SPRING DISCHARGE (IF TIPPED ON THE RIGHT SIDE) INTERLOCK MAY BE ACTUATED CAUSING THE BREAKER TO EITHER TRIP OR CLOSE UNEXPECTEDLY.

CAUTION

DO NOT WORK UNDER A BREAKER SUSPENDED ONLY BY THE BREAKER LIFT TRUCK.

In the parts replacement procedures which follow only the disassembly procedure is given unless specific operations are required in the reassembly. With no instructions to the contrary, reassembly is to be performed in the reverse order of the disassembly.

Some repairs will affect the operation of other sections of the mechanism. It is of utmost importance that following a repair that the adjustments and tests specified in the repair procedures be performed to assure that the breaker will operate as intended when it is returned to service.

A.5.2 PIN RETAINING RINGS

Pin retaining rings are used in a number of places throughout the mechanism to retain pins and shafts. REUSE OF RETAINING RINGS IS NOT RECOMMENDED. The retaining rings are removed by squeezing the "removal" ears together using standard pliers. To install a new retaining ring insert it into the groove and squeeze the "installation" ears to within 1/16" of each other.

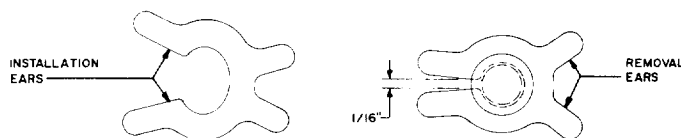

A.5.3 FRONT ANGLE PLATE AND CHARGE/DISCHARGE FLAG OPERATING ROD

Many mechanism repairs require removal of the front angle plate for access. The charge/discharge flag operating rod is removed in the process of removing the front angle plate.

With the breaker open and the closing spring discharged, remove the breaker front cover. Disconnect the spring from the operation counter. Remove ten bolts holding the front angle plate to the mechanism frame. Remove the 3 sheet-metal wire covers below each vacuum interrupter assembly. Carefully swing the left side of the front angle plate away from the mechanism to disconnect the charge/discharge flag operating rod from the flag. Disconnect the other end of the rod from the spring charge indicator arm. Fig. A1 shows front of breaker with Front Angle Plate removed.

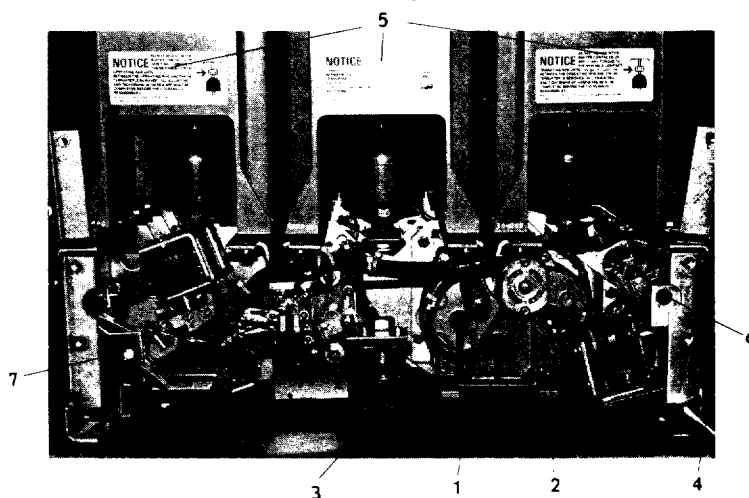

Fig. A1 Power/Vac* Breaker with Front Angle Plate Removed

- 1 — Clutch Assembly
- 2 — Gear Motor
- 3 — Swivel Caster
- 4 — Secondary Disconnect Handle (extended)
- 5 — Interrupter Supports
- 6 — Close Shaft
- 7 — Trip shaft

A.5.4 CLUTCH ASSEMBLY

With the front angle plate removed the clutch assembly (1) Fig. A1, may be slipped off the manual drive shaft of the gearmotor.

A.5.5 OPERATIONS COUNTER

The operations counter is removed by removing the two bolts which connect it to the swivel caster bracket and disconnecting the counter spring.

A.5.6 SWIVEL CASTER

Remove the front angle plate and the operations counter. The swivel caster, (3) Fig. A1, may be removed by removing bolt holding it to the breaker frame.

A.5.7 COUPLING CLAMPS

To remove the coupling clamp, (2) Fig. A2, which connects the operating rod to the vacuum interrupter, close the breaker and remove the two screws which hold the two halves of the coupling clamp together. When reinstalling, torque the two clamp screws to 10 to 12 foot pounds.

A.5.8 REPLACEMENT OF INTERRUPTER ASSEMBLIES

Interrupters are supplied as complete pole units which include the vacuum interrupter mounted in the interrupter support. The primary studs with disconnect fingers are part of the interrupter assemblies.

CAUTION

DO NOT ATTEMPT TO REMOVE OR REINSERT THE VACUUM INTERRUPTER IN THE INTERRUPTER SUPPORT ASSEMBLY. SPECIAL TOOLS AVAILABLE ONLY AT THE FACTORY ARE REQUIRED.

1. Close the breaker and remove the coupling clamp, (2) Fig. A2. Open the breaker and remove the four bolts holding the pole assembly to the mechanism and remove the old pole assembly.

2. Set the new pole assembly in place and install the four mounting bolts. Set the pole assembly so that the distance between the primary studs and the studs on the adjacent pole assembly are 10" apart.

3. Close the breaker using the Slow Closing Operation as described in paragraph 5.2. Perform the closing operation slowly while guiding the tip of the operating rod into the base of the movable contact rod, (3) Fig. A2, on the vacuum interrupter. After the breaker is fully closed install the coupling clamp.

4. Check and adjust the erosion indicator per paragraph 5.7 (if new interrupter assembly is installed), and the Wipe and Gap as described in paragraph 5.6.

5. Perform the Vacuum Interrupter Integrity test as described in paragraph 6.5.

6. Check primary stud wipe. (Refer to GEK 39672, Instructions and Recommended Parts For Maintenance. See section on Breaker Installation and Removal)

CAUTION

THE PRIMARY STUD WIPE CAN ONLY BE CHECKED WHEN THE SWITCHGEAR IS DE-ENERGIZED.

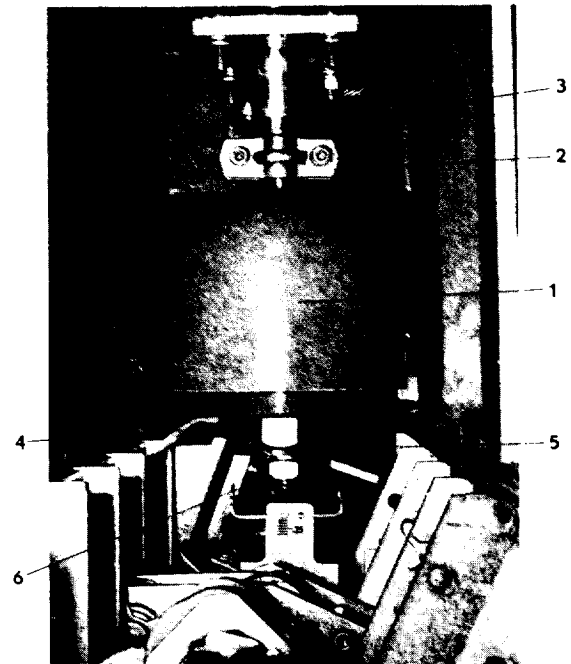

Fig. A2 Operating Rod — Viewed from Rear

- 1 — Operating Rod
- 2 — Coupling Clamp
- 3 — Movable Contact Rod of Vacuum Interrupter
- 4 — Erosion Indicator Reference Arm
- 5 — Erosion Disc
- 6 — Locknut

A.5.9 PRIMARY DISCONNECT CONTACT ASSEMBLY (Not applicable to 3000A)

Primary disconnect fingers may be removed by removing the two roll pins which holds them in place on the primary studs.

Coat the new primary disconnect fingers with 0282A2048-P009 grease at the contact surfaces.

A.5.10 OPERATING ROD

CAUTION

DO NOT TWIST THE MOVABLE END OF THE VACUUM INTERRUPTER. THIS COULD CAUSE LOSS OF THE VACUUM INTEGRITY.

To remove the operating rod, (1) Fig. A2, close the breaker, remove the coupling clamp and trip (open) the breaker. The operating rod is then removed by loosening the locknut, (6) Fig. A2, and unscrewing it from the wipe spring assembly.

To reinstall, screw the operating rod on the wipe spring assembly and adjust the distance between the top of the operating rod and the bottom of the movable contact rod, (3) Fig. A2, to the gap required for the breaker as shown in the following chart:

INTERRUPTER TYPE	GAP
PV-42A1	.445 TO .500
PV42B1, PV40A1, PV41A3	
PV-50, PV52	.545 TO .600
ALL OTHERS	.664 TO .719

Lock the operating rod in its initially adjusted position by tightening the locknut, (6) Fig. A2, against it. Slowly close the breaker as described in paragraph 5.2. Guide the tip of the operating rod into the recess in the bottom of the vacuum interrupter movable contact while the breaker is being slowly closed.

Install the coupling clamps. Check and readjust the breaker gap and wipe as described in paragraph 5.6.

A.5.11 CONTROL SWITCHES

Control switches may be removed from their mounting brackets by disconnecting the wires and removing the two mounting screws. Use a small screwdriver to remove and replace the switch on the bracket checking that the correct type, normally open or normally closed, is used. Reinstall wire and adjust per paragraph 5.9.

A.5.12 GEARMOTOR LIMIT SWITCH OPERATOR

With the breaker open and the closing spring discharged, remove the bolts that hold the gearmotor switch assembly and the switch operator, (5) Fig. A16, to the breaker side frame. Lower the switch assembly and maneuver the operator out through the breaker mechanism.

After reassembling adjust the switch as described in paragraph 5.9 and check electrical operation of the breaker in the test position in the metalclad switchgear.

A.5.13 TRIP OR CLOSE COIL

Remove the breaker front plate to gain access to the trip, (Fig. A3) or close coils (Fig. A4). To replace trip or close coils, cut wires at the butt connection (6) Fig. A3, loosen the coil bracket bolt closest to the plunger and remove the other bracket bolt. Pivot the bracket and remove the coil. Drive out the pole piece and install in the new coil. Slide the new

coil over the plunger and into the bracket on the plunger end. Pivot the other bracket into position, locate so the plunger does not bind and torque the bolts to 20-25 foot-pounds. Butt connect the wiring, check adjustment and electrical and mechanical operation. Check that the location of the coil wires is not such that they may interfere with mechanical operation. Use wire ties if necessary to make sure the wires are out of the way.

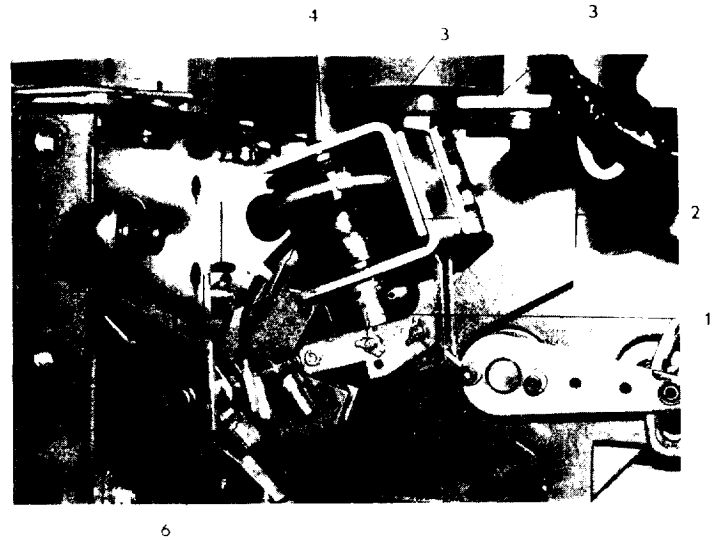

Fig. A3 Trip Coil

- 1 Plunger
- 2 Coil
- 3 Mounting Bracket
- 4 Pole Piece
- 5 Trip Shaft
- 6 Butt Connectors (cut)

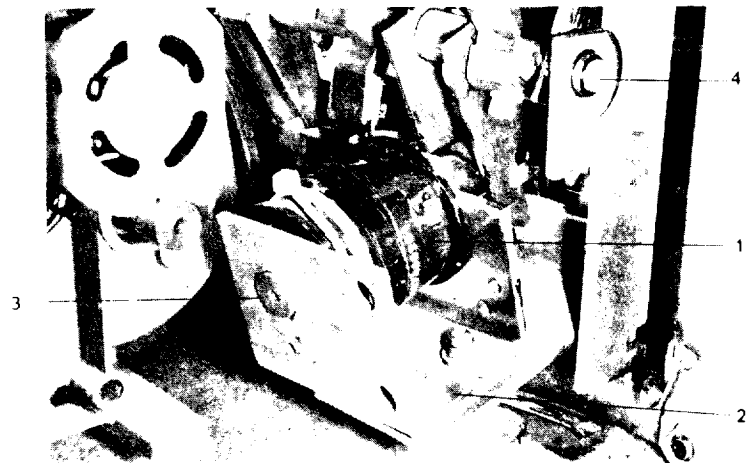

Fig. A4 Close Coil

- 1 Coil
- 2 Mounting Bracket
- 3 Pole Piece
- 4 Close Shaft

A.5.14 SECONDARY DISCONNECT BLOCK AND PINS

To remove the secondary (control power) disconnect block, extend the secondary disconnect handle, (4) Fig. A1, and remove the nuts from the two secondary disconnect guide pins, (1) Fig. A5. Remove the control wiring from the secondary disconnect block using Pin Removal Tool, (1) Fig. A6, P/N 453300-1 from AMP, Inc.

NOTE: If Pin Removal Tool is not available use a female pin socket with the retainer tabs flattened or removed to remove the male pins from the breaker side of the secondary disconnect. If replacing the female pirts (equipment side of disconnects) the pin removal tool must be used.

To replace the pin(s) on the control wiring cut the old pin off and strip the wire approximately $\frac{1}{4}$ inch and install new pin using AMP, Inc. crimping tool Model D Cat #69710, Die Cat #90306-1. Insert the pin into the disconnect block by pushing it into its recepticle until the engagement tabs on the pin spring out to retain the pin firmly in the block.

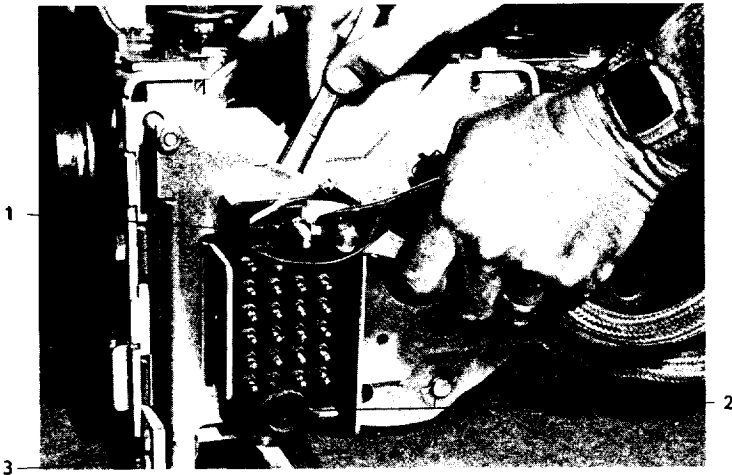

Fig. A5 Secondary Disconnect

- 1 — Guide Pin
- 2 — Guide Pin Hole — Pin Removed
- 3 — Secondary Disconnect Handle Mounting Bolts

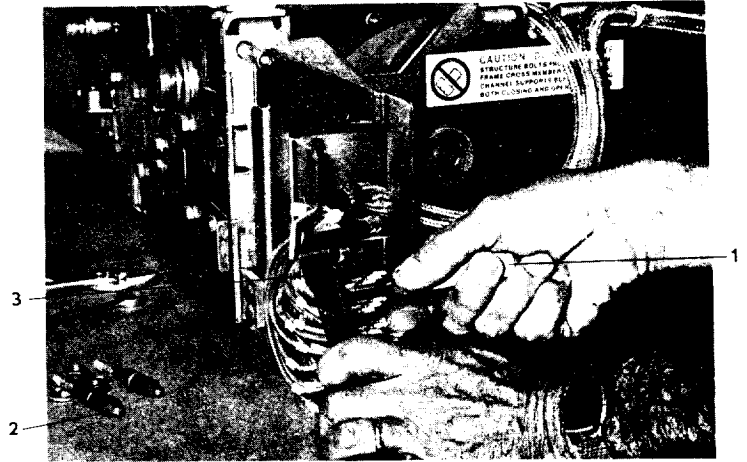

Fig. A6 Secondary Disconnect Pins Being Removed

- 1 — Pin Removal Tool
- 2 — Removed Guide Pins
- 3 — Secondary Disconnect Block

A.5.15 WIRING HARNESS

To replace the entire secondary control wiring harness the following steps are required:

Remove the pins from the secondary disconnect block. Cut all wire ties that hold the harness to the breaker frame. Remove the front angle plate and cut the wires to the trip coil, close coil and gearmotor (or disconnect at terminal block if installed). Disconnect the wires from each of the control switches and the anti-pump relay. (When removing wires note the position of each wire on the control switches so that when new harness is installed the wiring will be correct.

Install new wiring harness being careful to install the correct wire number to the proper location on the control switches.

After the new harness is installed perform a continuity check of each of the control circuits and auxiliary switch contacts at the secondary disconnect with the breaker opened and closed. Check the operation of the breaker electrically before returning the breaker to service.

A.5.16 SECONDARY DISCONNECT HANDLE

To remove the secondary disconnect handle remove the two bolts, (3) Fig. A5, which connect it to the secondary disconnect assembly at the rear of the breaker. With the bolts removed, pull the handle down and out through the front of the breaker.

A.5.17 ANTI-PUMP RELAY (52Y)

Remove the breaker front plate to gain access to the 52Y relay. Remove the wires to the 52Y relay, (1) Fig. A7, (and resistor if used). Remove the relay by removing the two bolts which hold it to the mounting plate.

Install the new relay in the reverse order. Check that the normally open and normally closed contacts are wired as shown on the schematic. (The positions of the NO and the NC contacts may be reversed on the new relay depending on the relay type supplied.)

Check the operation of the 52Y relay by closing the breaker electrically and maintaining the close signal while tripping the breaker manually after the spring charging motor has completed its charging cycle. If the breaker does not reclose the 52Y relay functioned properly.

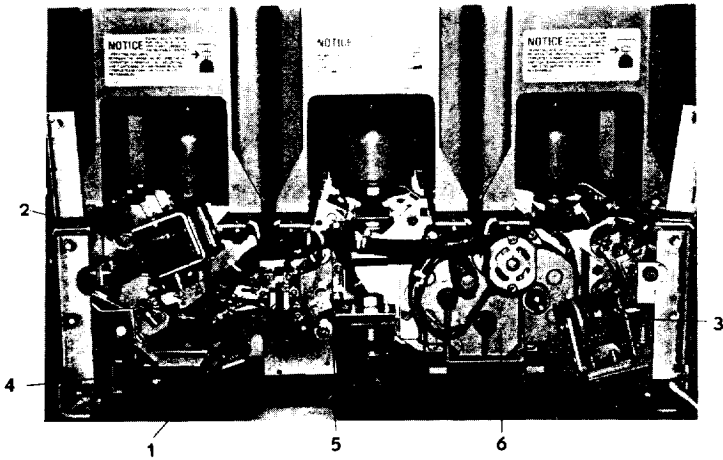

Fig. A7 Front View — Front Angle Plate Removed Electrical Components

- 1 — 52Y (Anti-Pump Relay)
- 2 — 52TC (Trip Coil)
- 3 — 52X (Close Coil)
- 4 — 52LCS (Latch Checking Switch)
- 5 — 52 Auxiliary Switch
- 6 — Spring Charging Motor

A.5.18 SPRING CHARGING MOTOR, SPLINE ADAPTER AND WIND SHAFT DRIVE PIN

With the closing spring discharged and the breaker open, remove the breaker front angle plate to gain access to the spring charging motor, (6) Fig. A7.

Cut the two motor leads at the butt connectors (or remove the motor leads from the terminal block if installed). Remove the four bolts holding the motor bracket, (2) Fig. A8, to the breaker frame. Withdraw the spring charging motor and mounting bracket from the breaker.

Examine the spline adapter, (4) Fig. A8, that the output shaft of the motor engages. If the spline adapter is damaged, remove it by removing the "star retainer" and the wind shaft drive pin. NOTE: To gain access to the "star retainer" the phase 3 interrupter assembly and phase 3 wire cover must be removed.

Remove the spring charging motor from the adapter plate and reinstall the new motor in the reverse order.

NOTE: If replacing a spring charging motor on breakers with a -0, -1, or -2 model designation, a new breaker front cover and new manual drive clutch may be included in the

replacement parts package. Follow the directions included in the parts package to complete the replacement.

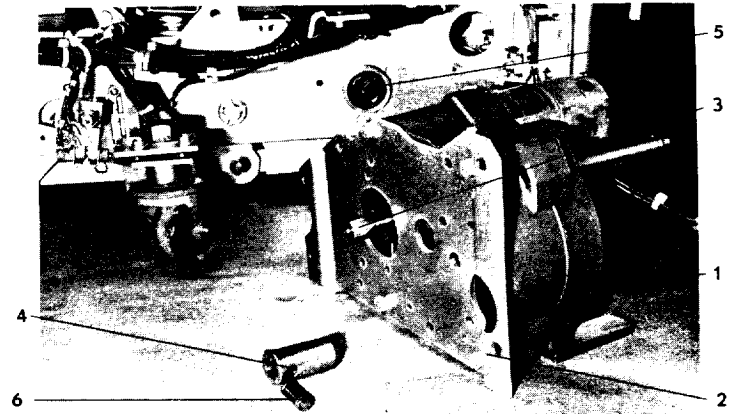

Fig. A8 Spring Charging Motor

- 1 — Gear Motor Assembly
- 2 — Motor Bracket
- 3 — Output Shaft
- 4 — Spline Adapter
- 5 — Spline Adapter Hole
- 6 — Wind Shaft Drive Pin

A.5.19 AUXILIARY SWITCH (52 Aux. Switch)

Remove the breaker front cover, and Y relay mounting plate and the front castor wheel for access to the auxiliary switch. Remove the wires and metal jumpers from the auxiliary switch, (5) Fig. A7.

NOTE

Check the position of the linkage of the auxiliary switch because it must go back in the same position or the switch will not operate properly. A "v" notch is on the end of the auxiliary switch shaft for reference.

Loosen the clamp bolt on the rear shaft of the auxiliary switch and remove the two bolts, (2) Fig. A9a, which mount the switch to the breaker frame to remove the switch.

Install the new switch in the reverse order.

Refer to Fig. A9b to check the switch adjustment. Adjustment is made by loosening the two bolts in the switch drive arm, (3) Fig. A9a. Check that the "A" contacts are closed when the breaker is closed and the "B" contacts are closed when the breaker is open.

* "A" contacts are closed when breaker is closed — for example (refer to Fig. 8 schematic) 2C and 4C are closed when breaker is closed and there should be continuity between pins 9 and 10 on the secondary disconnect.

** "B" contacts are closed when breaker is open — for example 1C should be closed when breaker is open and there should be continuity between pins 1 and 21 on the secondary disconnect.

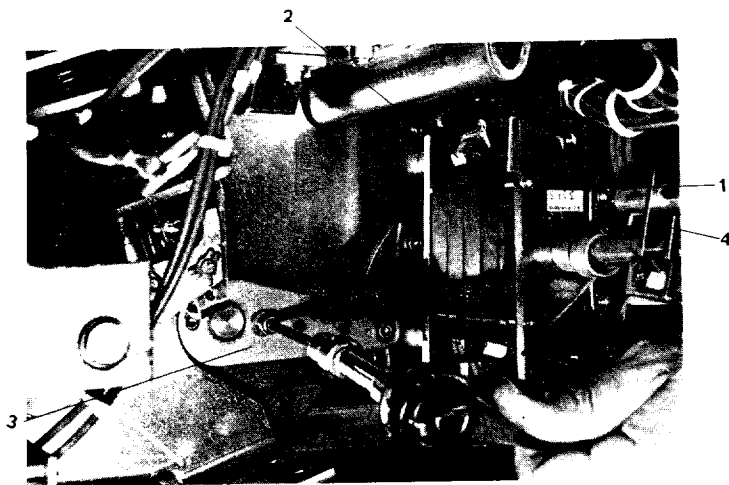

- 1 — Auxiliary Switch
- 2 — Mounting Bolt
- 3 — Switch Drive Arm
- 4 — Arm (-1, -2 and -3 model designators only)
(on -0 breakers the charge discharge flag is mounted directly to the switch shaft)

Fig. A9a 52 Auxiliary Switch

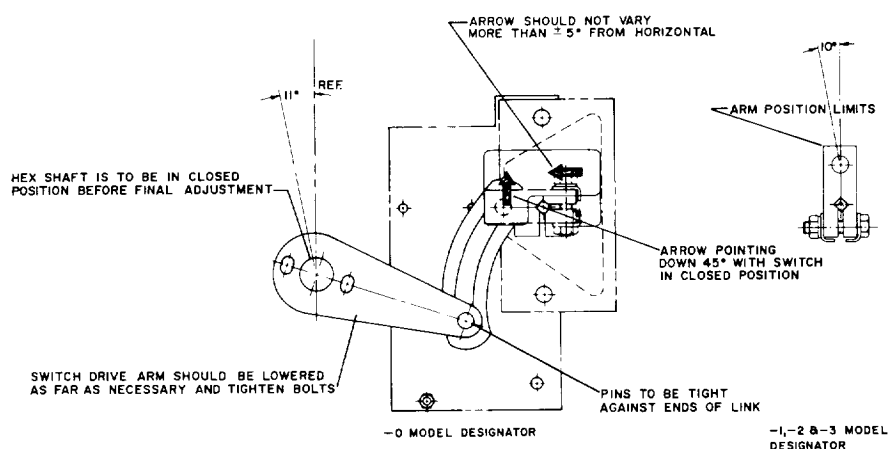

A9b Auxiliary Switch Adjustment

A.5.20 FLYWHEEL BRAKE (Not installed on -3 model designator)

To remove the brake, remove the clamp, (2) Fig. A10a, that holds the brake assembly to the pullrod and then remove the two bolts that mount the brake to the flywheel block. Reinstall the new brake in the reverse order.

Check that the brake is not binding against the flywheel by operating the breaker several times (25 open/close operations recommended). Binding will be indicated if the brake holds the flywheel in a position that prevents the wind pawl from engaging the wind hub. If binding occurs it can be corrected by using a pry bar between the brake and the flywheel to spring the brake mounting bracket away from the flywheel.

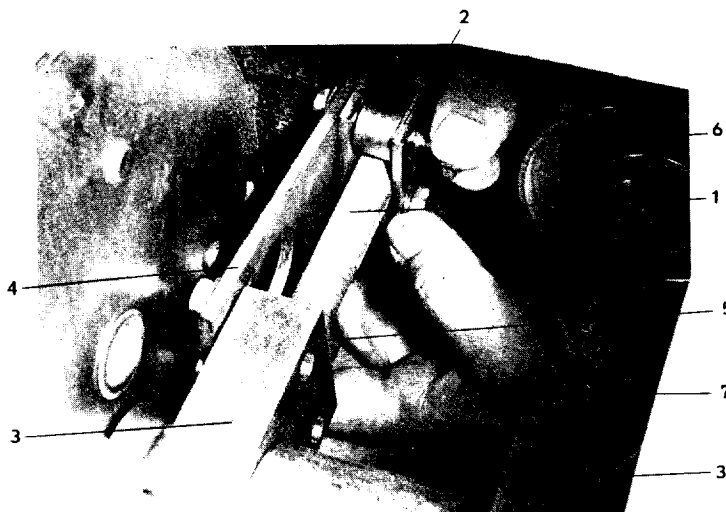

Fig. A10a Flywheel Brake

- 1 — Pullrod
- 2 — Brake Clamp
- 3 — Flywheel Block
- 4 — Brake Mounting Bracket
- 5 — Pull Rod Jam Nut
- 6 — Closing Spring
- 7 — Roll Pin

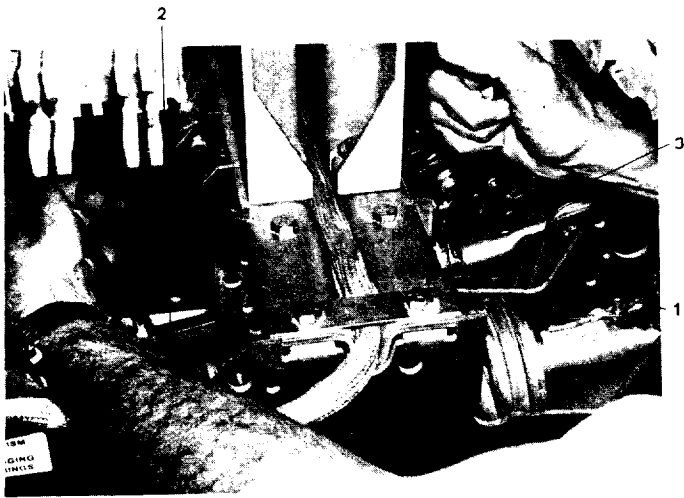

Fig. A10b Pull Rod

- 1 — Coupling
- 2 — Pull Rod
- 3 — Jam Nut

A.5.21 PULL ROD

Charge and gag the closing spring and press the manual close push button. Remove the flywheel brake assembly (Reference paragraph A.5.20). The pull rod is a turn buckle arrangement with right hand threads on one end and left hand on the other. Loosen the jam nuts, (5) Fig. A10a and (3) Fig. A10b, on each end of the pull rod and remove the pull rod by unscrewing it. Remove the jam nuts and install them on the new pull rod. Install the new pull rod and screw both ends in simultaneously. Set the length of the pull rod initially to approximately 13¼ inch between the flywheel block, (3) Fig. A10a, and the coupling, (1) Fig. A10b, attached to the adjustable throw transfer crank. Adjust the pull rod length as described in paragraph 5.3.

A.5.22 DASHPOT

For model designations -0 and -1 the dashpot and bracket assembly are removed by closing the breaker and removing the two pins which fasten the dashpot bracket to the breaker frame.

CAUTION

INSERT THE TRIP LATCH BLOCKING BOLT TO PREVENT INADVERTENT TRIPPING OF THE BREAKER.

Remove the old dashpot. Insert the new dashpot assembly in the reverse order.

For -2 -3 model designations, with the breaker open and discharged, remove the operating rod, (1) Fig. A2, and the erosion indicator reference arm, (4) Fig. A2, below the center pole assembly. Remove the two set screws in the top of the dashpot mounting bracket and pull out the mounting pins which connect the mounting block to the breaker frame. Remove the X-washers from the pin which holds the bottom of the dashpot to the phase #1 bell crank. Push the pin out through the access hole in the frame member.

Install the new dashpot in the reverse order. Recheck the wipe and gap on phase 2. **NOTE** — The following velocity check is not required but may be performed if desired.

Check that the velocity of the mechanism during tripping is acceptable by attaching a position transducer to the tapped hole in the opening stop bolt on the horizontal bar. Monitor the open/close operation of the primary contacts with low voltage leads across the primary studs. Trip the breaker and record the position of the horizontal bar as a function of time. Determine the average velocity of the horizontal bar during the first 75% of travel following primary contact parting. The velocity in this interval should be between 50 and 100 inches per second. Check the amount of mechanism rebound by examining the travel curve and recording the minimum gap, b. This distance should be equal to or greater than 75% of the full open gap, a, as illustrated in the example below.

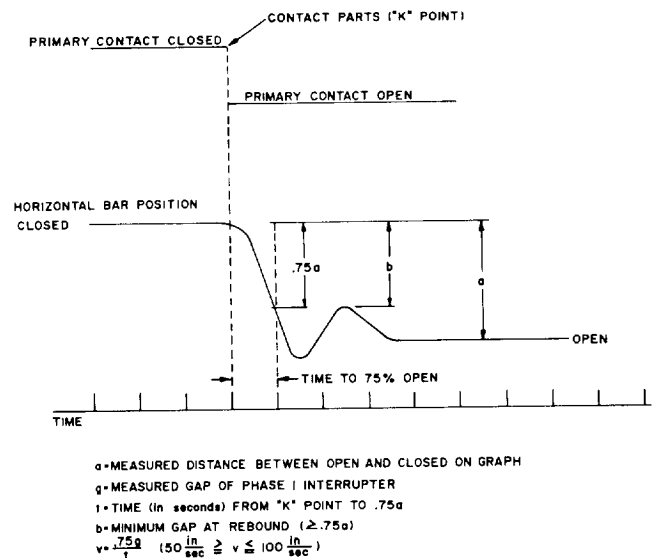

EXAMPLE OF VELOCITY & REBOUND CHECK

A.5.23 OVERTRAVEL STOP BOLTS

With the breaker open and closing spring discharged remove the locknut on the overtravel stop bolt, (5) Fig. 11, and use a screw driver to back the stop bolt out of the horizontal bar. Insert the new stop bolt until it touches the bottom of the opening stop block, and back out ¼ to ½ turn. Install locknut and torque to 20 to 25 foot pounds.

A.5.24 OPENING STOP BOLT AND HORIZONTAL CONNECTING BAR

In order to replace the opening stop bolt it is necessary to remove the horizontal connecting bar. To remove the horizontal connecting bar, gag the opening spring by first charging and gaging the close spring, pushing the manual close button and pulling the slow close pin. Slow close the breaker by turning the manual drive clutch until the opening spring is compressed to the point that a gag* can be inserted. **DO NOT FULLY CLOSE THE BREAKER** since this will

result in fully charging the opening spring which could shear the gag when the breaker is tripped. Trip the breaker after the opening spring gag is inserted.

- * On -2 and -3 Model use two $\frac{3}{8}$ " drill rod
- On -0 and -1 Model use one $\frac{3}{8}$ " drill rod

Remove the pin retaining rings from the three pins, (1) Fig. A11, connecting the horizontal connecting bar to breaker bell cranks. Remove the three bolts holding the stop bolt bracket, (2) Fig. A11, to the breaker side frame. Remove the Opening Stop Bolt from the horizontal connecting bar by backing off the locknut, (3) Fig. A11, and unscrewing the Opening Stop Bolt.

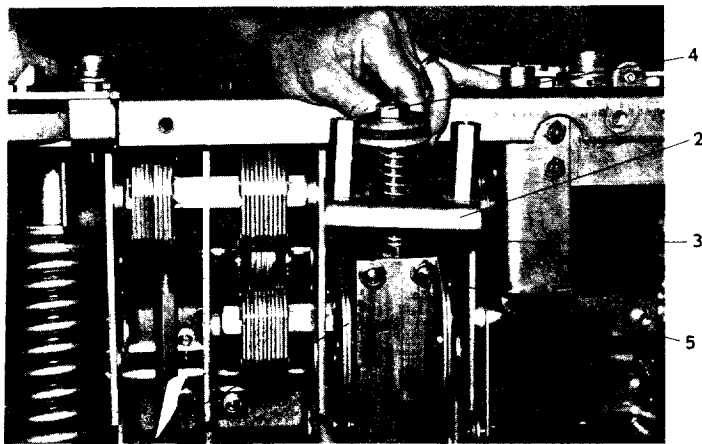

Fig. A11 Opening Stop Bolt

- 1 — Bell Crank Pin, Phase 1
- 2 — Stop Bolt Bracket
- 3 — Locknut
- 4 — Opening Stop Bolt

Install new Opening Stop Bolt and reinstall the horizontal connecting bar. Turn the manual wind clutch until the close spring is in its charged position (and trip latch reset). Push the manual close button and pull the slow close pin on the flywheel. Slow close the breaker and remove the gag from the opening spring. Charge the closing spring and remove the closing spring gag. Push the manual close button and the manual trip button to discharge the closing spring and open the breaker.

Check and adjust the trip latch clearance, the overtravel stop bolts and the wipe and gap as described in paragraphs 5.4, 5.5 and 5.6.

A.5.25 TOGGLE PIN

The toggle pin, (1) Fig. A12, may be replaced by removing the pin retaining ring on the end of the pin nearest the front of the breaker mechanism and pulling the pin out of the toggle linkage toward the back of the breaker mechanism. **THIS MUST BE DONE WITH THE BREAKER OPEN AND THE CLOSING SPRING CHARGED AND GAGGED.** Retain the spacers, (3) Fig. A12, for reuse.

After the toggle pin has been replaced check the pull rod adjustment as described in paragraph 5.3.

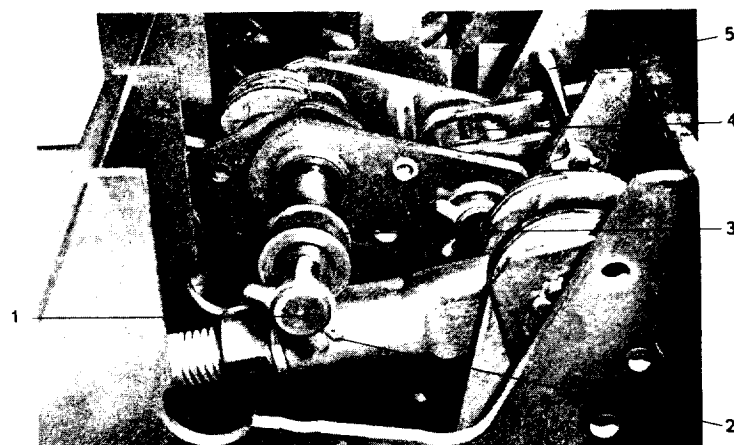

Fig. A12 Toggle Pin and Trip Roller

- 1 — Toggle Pin
- 2 — Pin Retaining Ring
- 3 — Spacer
- 4 — Trip Roller
- 5 — Toggle Positioning Pin

A.5.26 TRIP ROLLER

The trip roller, (4) Fig. A12, may be replaced by first removing the toggle pin and then removing the toggle positioning ring, (5) Fig. A12. Remove the pin retaining ring nearest the front of the breaker mechanism on the pin which mounts the trip roller to the toggle linkage. Pull the pin toward the rear of the breaker mechanism, until the trip roller can be removed.

After reassembly check the pull rod adjustment and trip latch clearance as described in paragraph 5.3 and 5.4.

A.5.27 CLOSE ROLLER

Charge and gag the closing spring. Press the manual close button to release the flywheel. Rotate the flywheel by hand to put the close roller, (1) Fig. A13, near the bottom of the mechanism. Remove the outboard retaining ring and then remove the pin which mounts the close roller to the flywheel.

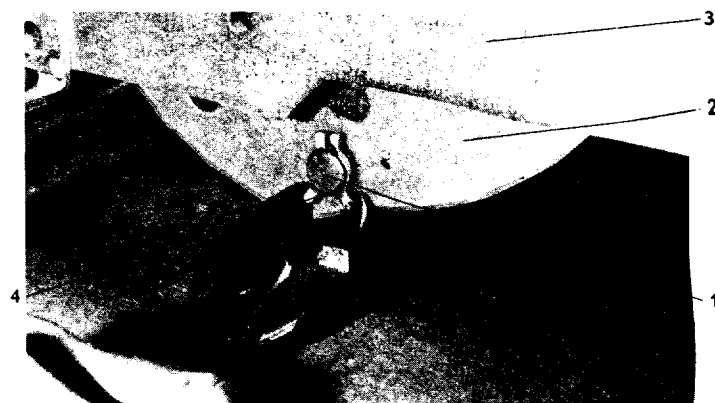

Fig. A13 Close Roller

- 1 — Close Roller Pin
- 2 — Flywheel
- 3 — Breaker Frame
- 4 — Pin Retainer Ring

A.5.28 TRIP SHAFT ASSEMBLY (Forward)

Remove the front angle plate (paragraph A.5.3) and the phase one (left side facing breaker) interrupter assembly (paragraph A.5.7). With the breaker open and the closing spring charged and gagged, use end cutting nippers, (8) Fig. A14, to cut the clamp which retains the trip shaft drive pin. Remove the trip shaft drive pin and the trip coil (paragraph A.5.13). Observe the position of the trip shaft torsion spring, (2) Fig. A14 to assure that it is positioned the same way when the trip shaft assembly is replaced. Remove the two bolts which mount the bracket (3) Fig. A14, to the mechanism frame.

After reassembly check that the breaker operates electrically as well as manually.

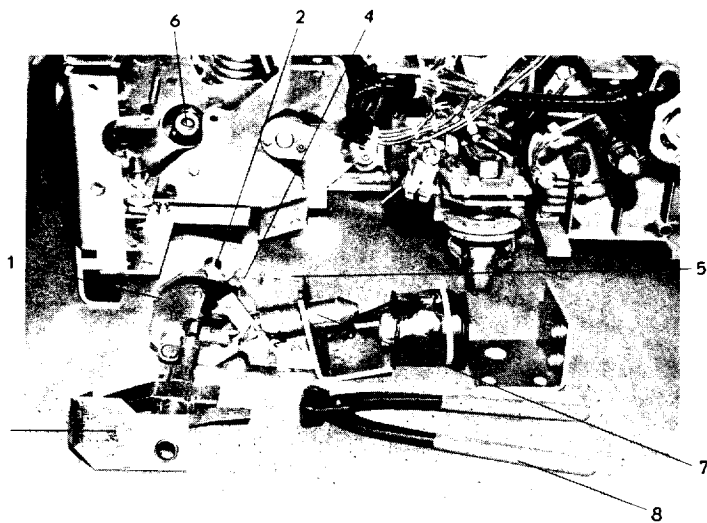

Fig. A14 Trip Shaft (Forward) Removal

- 1 — Trip Shaft (Forward) Assembly
- 2 — Torsion Spring
- 3 — Mounting Bracket
- 4 — Clamp
- 5 — Drive Pin
- 6 — Trip Shaft Rear
- 7 — Trip Coil Plunger
- 8 — End Cutting Nippers

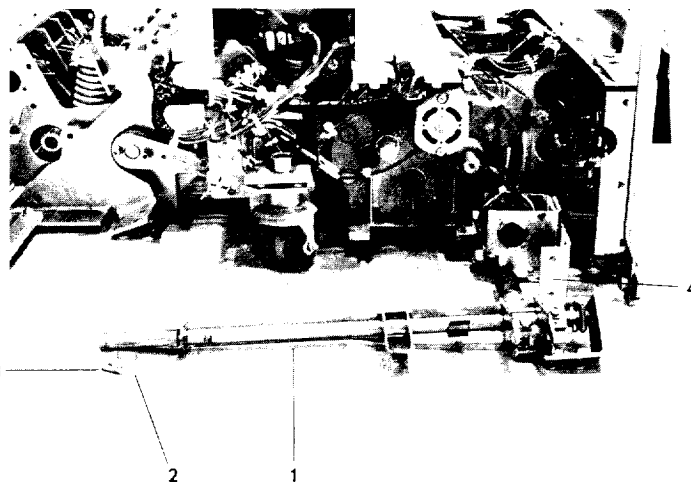

Fig. A15 Close Shaft (Forward) Removal

- 1 — Close Shaft (Forward)
- 2 — Clamp
- 3 — Drive Pin
- 4 — Close Coil Mounting Bracket

A.5.30 CLOSE SHAFT (Rear)

To remove the close latch remove the rear frame of the breaker mechanism and the phase 3 (right side facing front of breaker) interrupter assembly (paragraph A.5.7). Extend the secondary disconnect handle before removing the rear frame.

CAUTION

THE CLOSING SPRING SHOULD BE CHARGED, GAGGED AND THE MANUAL CLOSE BUTTON PUSHED BEFORE THE REAR FRAME IS REMOVED.

The rear frame contains a bearing which supports the rear end of the flywheel. Remove the rear frame carefully so as not to pull the forward end of the flywheel from its support. Cut the clamp, (3) Fig. A16, that retains the pin connecting the front and rear section of the close shaft using end cutting nippers. Observe the position of the closing shaft torsion spring (see Fig. A16) so that it can be installed in the same location.

A.5.29 CLOSE SHAFT ASSEMBLY (Forward)

Remove the front angle plate (paragrph A.5.3) and the phase 3 (right side facing breaker) interrupter assembly (paragraph A.5.7). With the breaker open and the closing spring discharged, use end cutting nippers to cut the clamp which retains the close shaft drive pin. Remove the drive pin, (3) Fig. A15. Disconnect the charge/discharge mechanism spring. Remove the close coil (paragraph A.5.13) and maneuver the shaft out through the front of the breaker.

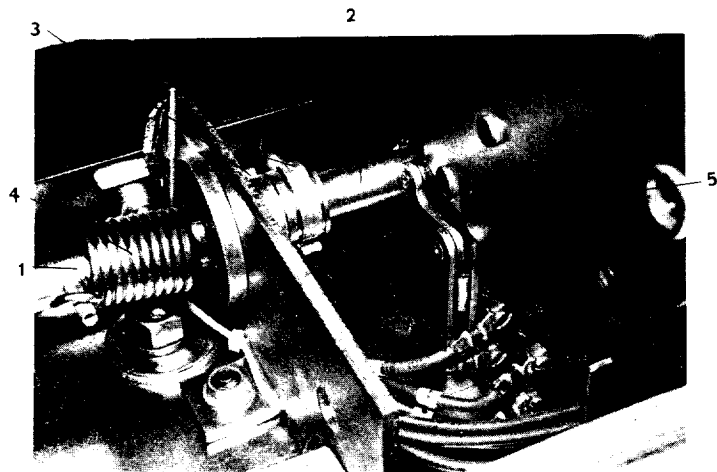

Fig. A16 Close Shaft (Rear) Viewed from below.

- 1 — Close Shaft (rear)
- 2 — Close Shaft (Forward)
- 3 — Clamp
- 4 — Torsion Spring
- 5 — Gear Motor Limit Switch Operator

A.5.31 CLOSING SPRING

CAUTION

DO NOT REMOVE THE GAG PIN FROM THE NEW CLOSING SPRING ASSEMBLY UNTIL IT HAS BEEN INSTALLED IN THE BREAKER. THE CHARGED CLOSING SPRING CONTAINS VERY HIGH ENERGY WHICH COULD RESULT IN SEVERE INJURY IF RELEASED IN AN UNCONTROLLED MANNER.

A. SPRING ASSEMBLY CAN BE GAGGED

To remove the closing spring charge and gag it and push the manual close push button. Push the manual trip push button to assure that the breaker is open. Disconnect the closing spring assembly, (6) Fig. A10a, by driving the roll pin out that connects the closing spring assembly to the flywheel block. The closing spring can then be removed through the bottom of the breaker.

B. SPRING ASSEMBLY DAMAGED AND CANNOT BE GAGGED

The closing spring can be removed by driving out the roll pin that connects the closing spring, (6) Fig. A10a, shaft to the flywheel block and then removing the left rear wheel assembly and the closing spring gag interlock on the left side frame. THESE OPERATIONS MUST BE PERFORMED WITH THE CLOSING SPRING DISCHARGED. The end of the closing spring opposite the flywheel can then be forced down from the breaker frame and the closing spring shaft pulled out of the flywheel block.

CAUTION

THERE IS SOME COMPRESSION REMAINING IN THE CLOSING SPRING EVEN THOUGH IT IS DISCHARGED. USE A LONG BAR TO FORCE THE SPRING ASSEMBLY AWAY FROM THE FRAME AND DO NOT STAND DIRECTLY IN LINE WITH THE DIRECTION OF THE SPRING FORCE SINCE SOME ENERGY WILL BE RELEASED WHEN THE SPRING CLEARS THE FRAME.

A.5.32 FLYWHEEL ASSEMBLY

Remove the closing spring (paragraph A.5.31) and the pull rod (paragraph A.5.21). Remove the flywheel brake paragraph A.5.20, (not applicable to -3 model design). Remove the pin retaining ring on the rear close shaft. Remove the spring for the closing spring gag interlock from the rear frame. Extend the secondary disconnect handle and remove the bolts which hold the rear frame to the mechanism frame. Carefully pull the rear frame away from the mechanism. Rotate the closing shaft to a position where it does not interfere with the flywheel and carefully slide the flywheel assembly out of the mechanism.

When reassembling, lift the gearmotor limit switch actuator, (5) Fig. A16, before sliding the flywheel assembly into place. After reassembly perform a complete adjustment of the mechanism as described in section 5, Mechanical Checks and Adjustments, and then operate the breaker electrically several times before returning the breaker to service.

A.5.33 SPRING DISCHARGE INTERLOCK

With the breaker open and the closing spring discharged, remove the two bolts, (3) Fig. A17, which mount the spring discharge interlock to the right side frame of the breaker. Remove the spring discharge interlock.

On reassembly check the adjustment of the close latch monitor switch, (2) Fig. A17, as described in paragraph 5.9.

CAUTION

THE METALCLAD SWITCHGEAR MUST BE DE-ENERGIZED FOR THE FOLLOWING TEST.

Check that the spring discharge interlock performs its function by performing the interface test with the metal-clad switchgear as described in GEK 39672 in the section "Spring Discharge Interlock".

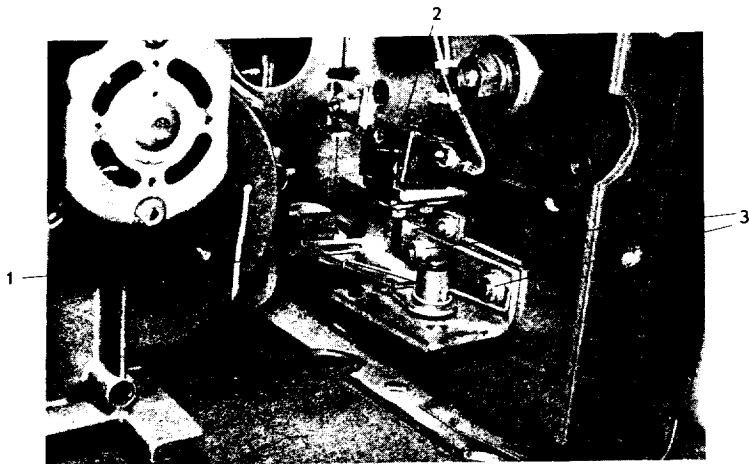

Fig. A17 Spring Discharge Interlock — Shown with close coil and close shaft removed.

- 1 — Spring Discharge Interlock
- 2 — 52 CL/MS (close latch monitor switch)
- 3 — Mounting Bolts

A.5.34 NEGATIVE INTERLOCK

With the breaker open and the closing spring discharged remove the two bolts, (6) Fig. A18, holding the interlock to the left side frame of the breaker and two bolts, (3) Fig. A18, to the trip coil mounting frame. Remove the latch checking switch (52LCS) and the negative interlock return spring. Slide the negative interlock out through the bottom of the mechanism frame.

On reassembly, check the adjustment of the latch checking switch (52LCS) as described in paragraph 5.9.

CAUTION

THE METALCLAD SWITCHGEAR MUST BE DE-ENERGIZED FOR THE FOLLOWING TEST.

Perform the interface test with the metalclad switchgear as described in GEK 39672 in the section "Negative Interlock".

A.5.35 REDUNDANT NEGATIVE INTERLOCK

Remove the redundant negative interlock return spring, (5) Fig. A18, and the two bolts holding the interlock, (2) Fig. A18, to the mechanism frame. Slide the interlock out through the bottom of the breaker.

CAUTION

THE METALCLAD SWITCHGEAR MUST BE DE-ENERGIZED FOR THE FOLLOWING TEST.

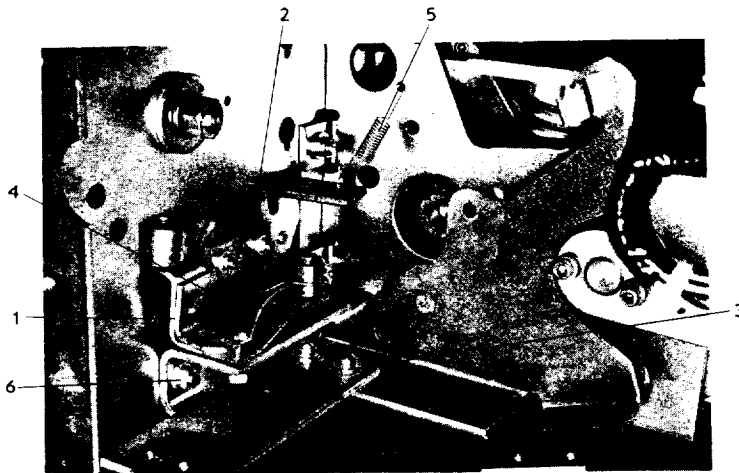

Fig. A18 Negative and Redundant Negative Interlock (Shown with trip coil, trip shaft and latch checking switch removed)

- 1 — Negative Interlock
- 2 — Redundant Negative Interlock
- 3 — Trip Coil Mounting Frame Bolts
- 4 — Negative Interlock Return Spring
- 5 — Redundant Negative Interlock Return Spring
- 6 — Mounting Bolt

On reassembly perform the interface test as described in GEK 39672 in the section, "Negative Interlock". Since the negative interlock operates at nearly the same time as the redundant negative interlock it will be difficult to determine which of the two interlocks cause actuation of the breaker trip shaft. Use a flash light and watch the action of the redundant negative interlock roller as the breaker is racked into and out of the connected position to assure that it is operating correctly to actuate the trip shaft if the negative interlock was not operating.

A.5.36 CLOSING SPRING GAG INTERLOCK

With the closing spring discharged, remove the closing spring gag interlock return spring, (5) Fig. A19, and the retaining ring that holds the interlock lever to the closing spring bracket. Remove the closing spring gag interlock by lifting it from the pin in the closing spring bracket.

After reinstallation of the closing spring gag interlock check that it interferes with the rail of the breaker lift truck when the closing spring is gagged.

CAUTION

DO NOT ATTEMPT TO GAG THE CLOSING SPRING EXCEPT WHEN IT IS CHARGED.

A.5.37 RACKOUT ARM ASSEMBLY — STANDARD

Remove the two bolts holding the rackout arm, (2) Fig. 8, to the breaker frame. Remove the two bolts holding the rackout arm angle bracket to the front angle plate. No adjustments are required after reinstalling.

A.5.38 RACKOUT ARM ASSEMBLY — SEISMIC

The rackout arms for seismic breakers are similar to the standard rackout arms except that the support bracket is adjustable. The adjustment is made using a $\frac{7}{8}$ " open end wrench to turn an eccentric under the support bracket. The support bracket should be adjusted so that the distance between the support bracket and the short vertical section on the rackout arm is $1.000 + .030-.000$ inches. This allows the rackout arm to engage the racking block on the racking mechanism installed in the equipment and limit the front to back freedom of the breaker.

After the rackout arm has been installed insert the breaker into the test position in the equipment and check that the rackout arm engages the racking block and that there is .030 inch maximum front to back freedom of movement.

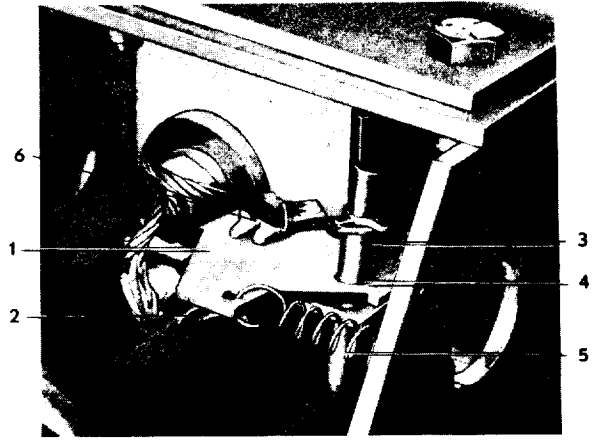

Fig. A19 Closing Spring Gag Interlock

(Shown in Unblocked Position)

- 1 — Close Spring Interlock Lever
- 2 — Blocking Hole
- 3 — Close Spring Blocking Pin
- 4 — Storage Hole
- 5 — Interlock Lever Return Spring
- 6 — Retaining Ring

APPENDIX B

POWER/VAC*

DIRECT ACTING UNDERVOLTAGE TRIP DEVICE

CONTENTS

	Page
B.1 Introduction	47
B.2 Safety	48
B.3 Shipping Position	48
B.4 Description and Principles of Operation	48
B.5 Removing or Installing Gag Bolt	49
B.6 Electrical Checks	52
B.7 Mechanical Adjustments	52
B.7.1 Hammer Assembly Reset Position	52
B.7.2 Drop Out Voltage	52
B.7.3 Device Position	52
B.7.4 Pull Rod Adjustment	53
B.7.5 Solenoid Reset	53
B.8 Removal and Replacement	
B.8.1 Removal	53
B.8.2 Replacement	53
B.9 Lubrication	53

ILLUSTRATIONS

Figure No.		Page No.
B1	Breaker With Front Angle Plate Removed	48
B2	Undervoltage Trip Device	50
B3	Typical Wiring Diagram for ML-17 Mechanism with Direct Acting Undervoltage Trip Device (52/UVD)	51

B.1 INTRODUCTION

This Appendix is applicable to Power/Vac* Breakers containing a Direct Acting Undervoltage Trip Device and provides instructions and explanations which are in addition to those of the main body of this manual.

The Undervoltage Trip Device is a factory installed unit which is an integral part of the breaker mechanism. Its function is to monitor the trip control voltage and to trip the breaker if that control voltage is lost.

* Registered Trademark of the General Electric Company

These instructions do not purport to cover all details or variations in equipment nor to provide for every possible contingency to be met in connection with installation, operation or maintenance. Should further information be desired or should particular problems arise which are not covered sufficiently for the purchaser's purposes, the matter should be referred to the General Electric Company.

To the extent required the products described herein meet applicable ANSI, IEEE and NEMA standards; but no such assurance is given with respect to local codes and ordinances because they vary greatly.

B.2 SAFETY

All safety precautions contained in the main body of GEK 39671E apply. Special emphasis should be placed on the prohibition against working on the breaker with the test coupler engaged. When it is necessary to work on a closed breaker, the Undervoltage Trip Device should be gagged rather than applying voltage to the device to permit the breaker to close.

Fig. B1 Breaker With Front Angle Plate Removed

- 1 — Undervoltage Device Coil
- 2 — Reset Lever Assembly
- 3 — Adjusting Spring
- 4 — Trip Coil
- 5 — Trip Shaft
- 6 — Gag Bolt

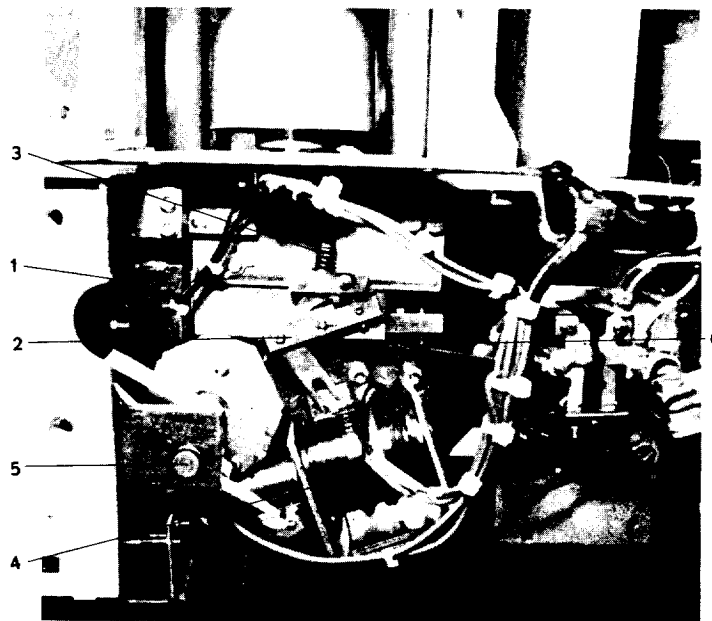

B.3 SHIPPING POSITION

The Power/Vac* Breaker is shipped from the factory with the Undervoltage Trip Device gag bolt installed in the gag (up) position to allow the breaker to be shipped in the closed position. This bolt should be kept in the gagged position during mechanical check-out of and maintenance on the breaker.

CAUTION

BACK THE GAG BOLT TO ITS DOWN (UN-GAGGED) POSITION BEFORE PLACING THE BREAKER IN SERVICE. IF THIS IS NOT DONE, THE BREAKER WILL OPERATE AS IF THE UNDER-VOLTAGE TRIP DEVICE WAS NOT INSTALLED. BACK THE GAG BOLT DOWN ONLY WHEN THE BREAKER IS IN THE TRIPPED (OPEN) POSITION.

B.4 DESCRIPTION AND PRINCIPLE OF OPERATION

The Undervoltage Trip Device is a spring actuated tripping mechanism which monitors the trip control voltage and is actuated by loss of that voltage to trip the breaker. Figure B2 shows the front and rear view of the device. In the following description, clockwise and counterclockwise rotation refer to the direction of rotation in the front view. When observing the rear view, the opposite rotation occurs.

With the breaker closed, the solenoid, Part No. 2, energized by the breaker trip control voltage, holds hammer assembly, Part No. 3, in its UP (counterclockwise) position with adjusting spring, Part No. 4, in compression. On loss of voltage to the solenoid the force on the hammer assembly is unbalanced and the adjusting spring accelerates the hammer assembly clockwise around its pivot pin, Part No. 14. The striker bolt, Part No. 5, on the hammer assembly, strikes the primary sear, Part No. 6, which is rotated clockwise releas-

ing intermediate sear, Part No. 7, which rotates counterclockwise to release striker assembly, Part No. 8. The tension in the striker spring, Part No. 9, drives the striker assembly clockwise. The lower tang of the striker assembly strikes a pin in the breaker trip shaft which causes the trip shaft to rotate and trip the breaker.

As the breaker opens the breaker output shaft, (Shaft DD in Fig. 4), rotates counterclockwise. The reset bellcrank, Part No. 10, mounted on the breaker output shaft, rotates causing two functions to occur simultaneously: (1) the hammer assembly is reset (solenoid retracted position) by the motion of the reset lever assembly, Part No. 11; and (2) the striker spring is cocked by the pullrod assembly, Part No. 12. As the striker spring is pulled to its cocked position, the primary and intermediate sears are reset by the sear spring, Part No. 13.

In this position (breaker is open and Undervoltage Trip Device is cocked) the device is set to perform its function when the breaker is reclosed. If trip control voltage is restored to the solenoid before the breaker is closed, the hammer assembly will remain in its counterclockwise location and the breaker will close normally. However, if the trip control voltage has not been restored, the solenoid will not hold the hammer assembly in its retracted position as the reset level assembly, Part No. 11, moves away during the closing stroke of the breaker. The hammer assembly will then drop causing the trip sequence to repeat.

The Undervoltage Trip Device is equipped with a gag bolt to allow the breaker to be operated when trip control voltage is not available. This feature is required for performing

maintenance on the breaker or for mechanical check out of the breaker.

The gag bolt, Part No. 1, identified by a red shank, may be installed in the UP position where it contacts the primary sear and prevents it from releasing when struck by the hammer assembly. This bolt must be backed out to its DOWN position before the breaker is placed in service in order for the device to perform its function.

CAUTION

GAG OR UNGAG THE DEVICE ONLY WHEN THE BREAKER IS IN THE TRIPPED (OPEN) POSITION. AND THE CLOSING SPRING DISCHARGED OR GAGGED.

B.5 REMOVING OR INSTALLING GAG BOLT

The gag bolt, (1) Fig. B2, has a red shank and is accessible from the bottom side of the breaker. Access may be obtained by tipping the breaker gently on its side.

CAUTION

1. DO NOT WORK UNDER A BREAKER SUSPENDED BY THE BREAKER LIFT TRUCK.

2. BEFORE TIPPING A BREAKER ON ITS SIDE, ASSURE THAT IT IS OPEN AND DISCHARGED. IF THIS IS NOT DONE, THE INTERLOCK ROLLER ON THE SIDE OF THE BREAKER MAY CAUSE THE MECHANISM TO OPERATE.

3. GAG OR UNGAG THE DEVICE ONLY WHEN THE BREAKER IS OPEN AND THE CLOSING SPRING DISCHARGED OR GAGGED.

PROCEDURE

1. Check that the breaker closing spring, is discharged or gagged and that the breaker is tripped (open).

2. Either tip the breaker on its side or raise the breaker to gain access to the gag bolt.

3. To gag the device, screw the bolt to its UP position until it contacts the bottom of the primary sear.

4. To ungag the device back the gag bolt out to its DOWN position. In this position no threads on the gag bolt will be engaged.

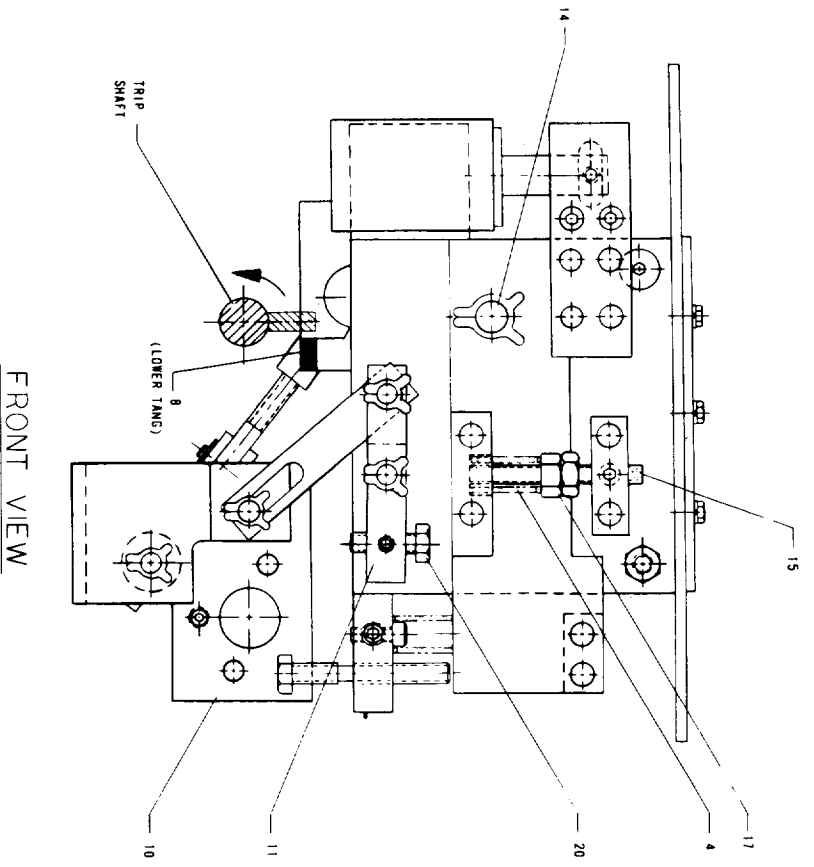

FRONT VIEW

(SHOWN WITH DEVICE UNGAGGED)

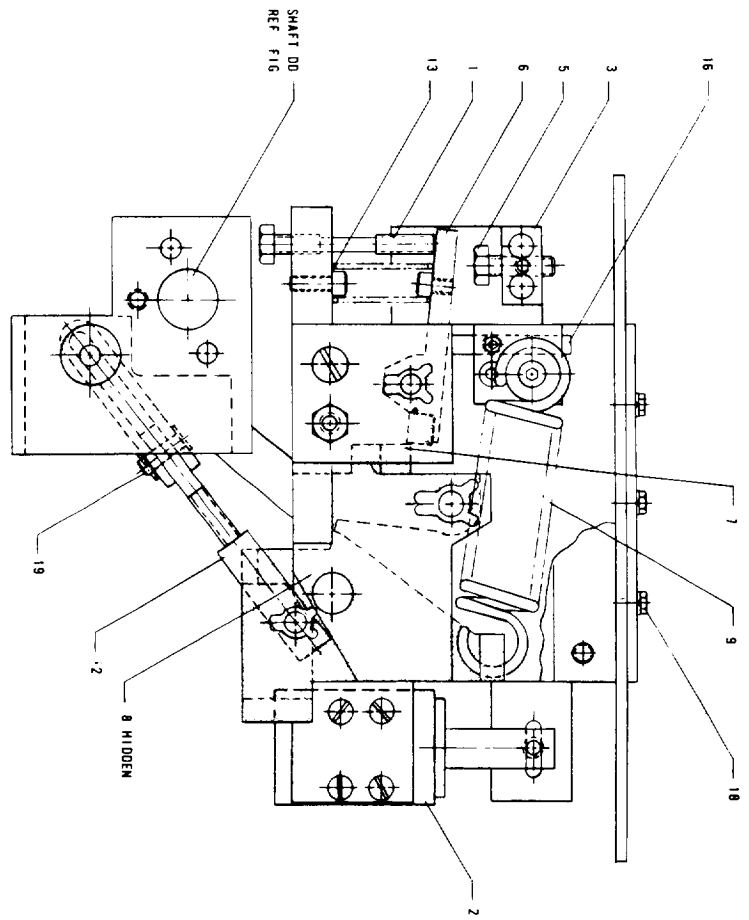

REAR VIEW

(SHOWN WITH DEVICE GAGGED)

Fig. B2 Undervoltage Trip Device
(SHOWN WITH BREAKER CLOSED)

- | | |
|--------------------------|--|
| 1. GAG BOLT | 12. PULL ROD ASSEMBLY |
| 2. SOLENOID | 13. SEAR SPRING |
| 3. HAMMER ASSEMBLY | 14. HAMMER ASSEMBLY PIVOT |
| 4. ADJUSTING SPRING | 15. HAMMER ASSEMBLY RESET POSITION SCREW |
| 5. STRIKER BOLT | 16. PRIMARY SEAR |
| 6. PRIMARY SEAR | 17. INTERMEDIATE SEAR ENGAGEMENT SCREW |
| 7. INTERMEDIATE SEAR | 18. STRIKER ASSEMBLY |
| 8. STRIKER ASSEMBLY | 19. SPRING ADJUSTMENT NUT |
| 9. STRIKER SPRING | 20. MOUNTING SCREWS |
| 10. RESET BELLCRANK | 21. CONNECTING PIN |
| 11. RESET LEVER ASSEMBLY | 22. RESET BOLT |

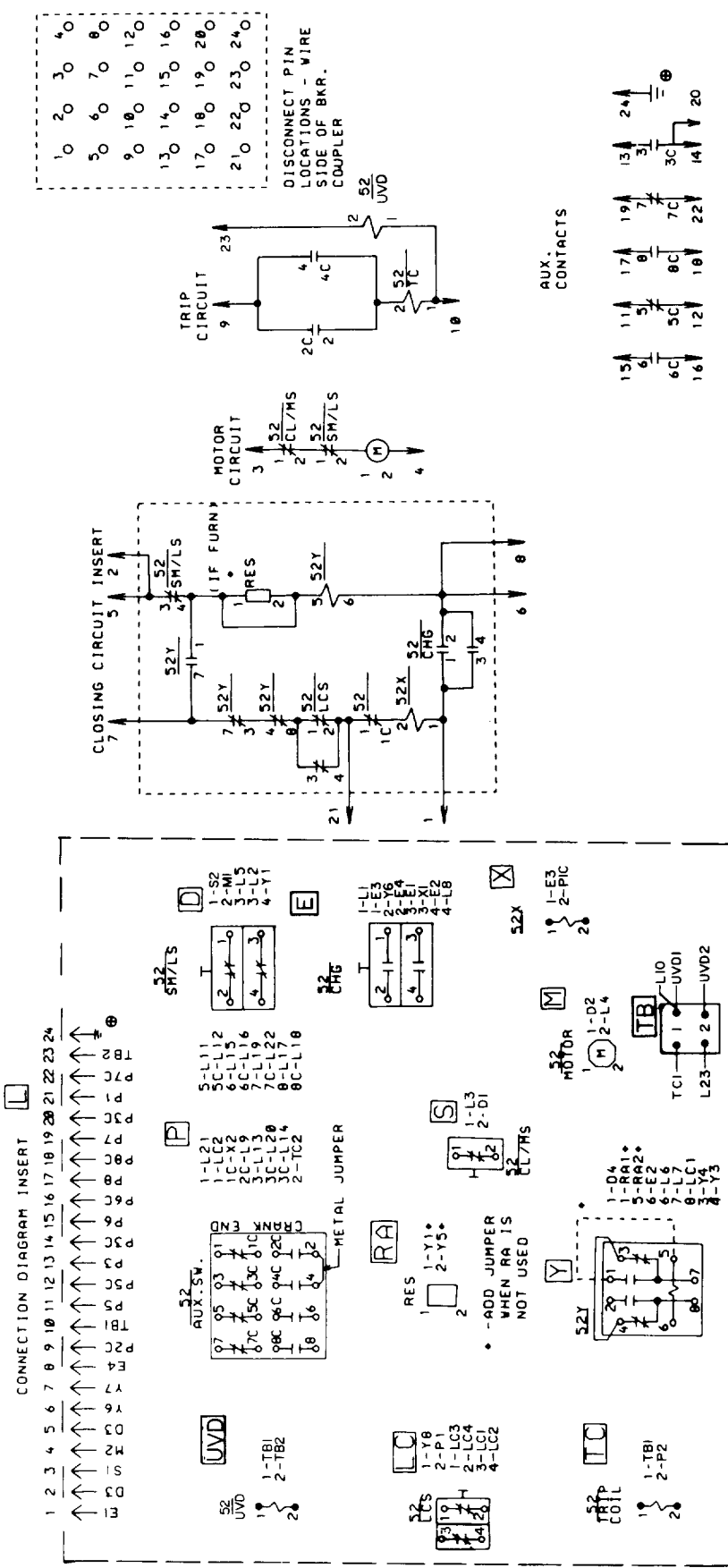

NOTES

- 52 CLOSING LATCH MONITORING SWITCH IS CLOSED WHEN LATCH IS CAPABLE OF BLOCKING FULLY CHARGED CLOSING SPRING. HELD OPEN BETWEEN DISC. & CONNECT POSITIONS.
- 52 LIMIT SWITCH FOR SPRING CHARGING MOTOR- CONTACTS (1-2)(3-4) OPEN WHEN SPRINGS ARE FULLY CHARGED.
- 52 CONTACTS CLOSED WHEN CLOSING SPRINGS ARE FULLY CHARGED.

BREAKER SHOWN "OPEN" AND WITH CLOSING SPRING "DISCHARGED"

- 52X SPRING RELEASE COIL OPERATES LATCH WHICH RELEASES CLOSING SPRING TO CLOSE 52.
- ⊕ GROUND PIN USED FOR INSPECTION BOX ONLY.
- 52 TRIP LATCH CHECKING SWITCH CLOSED WHEN LATCH IS RESET.
- * SEE TABLE FOR RES. VALUE

AUX. CONTACTS

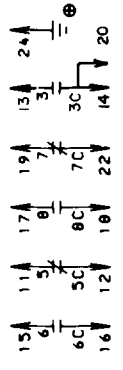

P	CLOSING CIRCUIT VOLTAGE	RESIST (#)
001	48VDC	0
002	125VDC	0
003	250VDC	3500
004	115VAC	0
005	230VAC	0

CONTACT TYPE	N/D	N/C
CL/MS	X	
LCS	X	
CHG		X
SM/LS	X	

Fig. B3 Typical Wiring Diagram for ML-17 Mechanism with Direct Acting Undervoltage Trip Device (52/UVD)

B.6 ELECTRICAL CHECKS

A typical wiring diagram is shown in Fig. B3 for a Power/Vac* Breaker containing an Undervoltage Trip Device. Check the wiring diagram supplied with the actual circuit breaker for its wiring.

Electrical checking consists of testing to see that the breaker will close when nominal trip control voltage is applied and that a closed breaker will trip when that voltage is removed.

NOTE

The device gag bolt must be in the DOWN (ungagged) position while performing the electrical tests.

CLOSING — Use a test connector or the test position in the metalclad switchgear to apply nominal trip control voltage across the device solenoid. Close the breaker either electrically or manually and check that the breaker closed and stayed closed.

TRIPPING — Remove the trip control voltage. The breaker should trip immediately. NOTE: If performing the test in the metalclad switchgear, trip control voltage may be removed by pulling the trip fuse.

B.7 MECHANICAL ADJUSTMENTS

There are five adjustments required for proper functioning of the Undervoltage Trip Device. These are:

1. Hammer assembly reset position.
2. Drop out voltage.
3. Position with respect to trip shaft.
4. Pullrod adjustment.
5. Solenoid reset.

Each of these adjustments has been set at the factory and should be readjusted only if there is a malfunction or if the device has been removed from the breaker. To gain access to the device to perform these adjustments, it is necessary to remove the breaker front angle plate and the trip coil.

B.7.1 HAMMER ASSEMBLY RESET POSITION

The hammer assembly reset position screw, (15) Fig. B2, is adjusted to allow the solenoid plunger to fully engage the solenoid. Loosen the set screw which locks Part No. 15 in position and using a screwdriver through the hole in the top plate of the device, adjust the reset position screw until it just contacts the plate on the hammer assembly when the solenoid is fully retracted (hammer assembly in the full counterclockwise Position). Back the reset position screw out $\frac{1}{8}$ turn to assure full engagement of the solenoid. Lock in position by tightening the set screw.

B.7.2 DROP OUT VOLTAGE

The drop out voltage is adjusted by the amount of compression of the adjusting spring, Part No. 4. Increasing the compression on the spring increases the voltage at which "drop out occurs" (it also increases the minimum voltage for the device to reset, i.e. for the solenoid to hold when the breaker is closed). The adjusting spring provides the energy to accelerate the hammer assembly to trip the device and

therefor must be compressed when the device is charged. It is recommended that the spring adjustment nut, Part No. 17, be set to cause the device to trip when the voltage is 15 to 20% of the nominal trip control voltage. After this adjustment has been made and after the device is reinstalled in the breaker and all other adjustments completed, set the trip control voltage to 85% nominal and check that the breaker will close and stay closed. If the breaker trips (i.e. fails to stay closed), decrease the compression on the adjusting spring, Part No. 4, until the unbalanced force between the solenoid and the adjusting spring is such that the solenoid stays reset during the closing operation of the breaker.

B.7.3 DEVICE POSITION

The position of the Undervoltage Trip Device relative to the breaker trip shaft may be adjusted only when the pullrod assembly, Part No. 12, and the reset lever assembly, Part No. 11, are disconnected. To disconnect the pullrod, gag the Undervoltage Trip Device and slow close the breaker to remove the tension from the pullrod. The pullrod connecting pin, Part No. 19, may then be removed by first removing the cotter pin which holds it in place. The reset lever assembly, Part No. 11, may be disconnected by removing the pin retaining ring which holds it in position.

The clearance between the lower tang on the striker assembly, Part No. 8, and the trip shaft pin should be set at .040 to .120 inch.

CAUTION

TO PREVENT ACCIDENTAL OPENING OF THE BREAKER, BLOCK THE TRIP LATCH AGAINST THE FRAME BY INSERTING A $\frac{3}{8}$ -16 BOLT (MINIMUM THREAD LENGTH $2\frac{3}{8}$ INCH) IN THE TRIP LATCH BLOCKING HOLE (4) IN FIG. 9.

The position adjustment is made by loosening the three mounting screws, Part No. 18, and positioning the device to its proper location. Retighten the mounting screws to lock the device in place.

B.7.4 PULLROD ADJUSTMENT

The pullrod, Part No. 12, transfers the motion of the reset bellcrank, Part No. 10, to the striker assembly, Part No. 8, to charge the striker spring, Part No. 9.

With the Undervoltage Device charged and gagged and the breaker tripped (open), adjust the two ends of the pullrod to the point that the holes for the connecting pin, Part No. 19, are aligned. Screw the threaded end in two and one-half turns further to provide over travel to the striker assembly. Slow close the breaker and connect the two halves with

the connecting pin and secure with a cotter pin. Trip the breaker and back the device gag bolt down to its ungagged position and check that the primary sear, Part No. 6, moves freely to its full reset position and that it will move easily using light finger pressure. If the primary sear does not reset completely, readjust the pullrod using an additional one-half turn of engagement.

B.7.5 SOLENOID RESET

The reset lever assembly, Part No. 11, repositions the hammer assembly, Part No. 3 to reset the solenoid when the breaker is tripped. The reset bolt, Part No. 20, is to be adjusted to fully reset the solenoid when the breaker is tripped. Loosen the set screw which holds Part No. 20 in position and adjust Part No. 20 to hold the hammer assembly, Part No. 3, to within .005 inch of its full counterclockwise position. Lock the reset bolt in place by tightening its set screw.

B.8 REMOVAL AND REPLACEMENT OF THE UNDERVOLTAGE TRIP DEVICE

CAUTION

REFER TO PARAGRAPH 5.2 PRIOR TO GAGGING THE CLOSING SPRING OR SLOW CLOSING THE BREAKER. REFER TO PARAGRAPH A.5.8 FOR REMOVAL AND REPLACEMENT OF THE INTERRUPTER ASSEMBLY.

B.8.1 REMOVAL

With the breaker open and the closing spring charged and gagged, remove the breaker front cover and the front angle plate. Remove the phase I interrupter assembly. Remove the breaker trip coil from its mounting bracket. Gag the undervoltage trip device by turning the gag bolt., (1) Fig. B2, to its "up" position. Disconnect and remove the reset lever assembly, (11) Fig. B2, from the reset bell crank, (10) Fig. B2, and the pivot on the device by removing the pin retainers.

Slow close the breaker to remove the tension from the striker spring, (9) Fig. B2, and the pull rod assembly, (12) Fig. B2. Disconnect the pull rod by removing the connecting pin, (19) Fig. B2, which is retained with a cotter pin.

Trip the breaker by pushing the negative interlock roller. Disconnect the solenoid leads from the terminal block. Remove the three bolts mounting the device to the breaker frame and maneuver it out through the front of the breaker.

B.8.2 REPLACEMENT

With the breaker open (tripped) and the closing spring charged and gagged, maneuver the device into position so that the mounting holes are aligned with the three mounting holes in the breaker frame. Mount the device so that the distance between the breaker trip shaft and the lower tang of the striker assembly, (8) Fig. B2, is .040 to .120 inch. Mounting screws, (18) Fig. B2, may be loosened if required to obtain this adjustment. Tighten the mounting screws to lock the device in place.

Set the pull rod adjustment as described in paragraph B.7.4 After the pullrod is adjusted trip the breaker.

Reinstall the reset lever assembly, (11) Fig. B2. It may be necessary to turn the reset bolt in a few turns to fit the new device. Hold the hammer assembly, (3) Fig. B2, in its up position when installing the reset lever. Adjust the reset bolt as described in paragraph B.7.5.

Connect the solenoid leads and check the dropout voltage as described in paragraph B.7.2.

Reinstall the phase I interrupter assembly.

B.9 LUBRICATION

Proper lubrication is important for maintaining reliable operation of the Undervoltage Trip Device. When maintenance is performed on the Power/Vac breaker apply a few

drops of synthetic oil such as Mobil #1 at each pivot pin and to each moving contact surface.

GENERAL ELECTRIC COMPANY
SWITCHGEAR BUSINESS DEPARTMENT
BURLINGTON, IOWA 52601

GENERAL  **ELECTRIC**